

Catálogo 2012

1 Serie 50000

Racordaje automático

Push-in Fittings

2 Serie 55000

Racordaje automático en tecnopolímero

Technopolymeric Push-in Fittings

3 Serie 57000

Racordaje automático con anillo metálico

Push-in Fittings with metal collet

4 Serie 70000

Racordaje automático food grade

Food Grade Push-in Fittings with metal collet

5 Serie Inox: 60000 - 61000 - 62000 - 63000

Racordaje en acero inoxidable automático, rápido, accesorios y multipresa

Stainless steel Push-in Fittings, Push on fittings, Accessories and Multisocket

6 Serie 89000

Racordaje automático con anillo metálico para tubo en pulgadas

Push-in Fittings with metal collet and inch tube

7 Serie 58000

Racordaje automático para alta presión

Hight pressure push-in fittings

8 Serie 1000

Racordaje rápido

Push-on Fittings

9 Serie Function

Racordaje a funciones neumáticas

Function Fittings

10 Serie Ghilux

Válvulas a esfera

Ball Valves

11 Serie Accessories - 1800 - 15000

Racordaje standard y portagoma - *Fixtures and Fittings - Hose adapters*

Racordaje con Conexión a bayoneta - *Fittings with bayonet connection*

12 Serie Tubes

Tubos en material plástico

Spiral and Tubes

13 Serie Quick Couplings

Enchufes rápidos, Enchufes de seguridad y Pistolas sopladoras

Automatic Quick Couplings, Safety Couplings and Blow Guns

14 Serie Compression Fittings

Racordaje a compresión

Compression Fittings

15 Serie Valves

Válvulas electroneumáticas, neumáticas y manuales

Manual, Pneumatic and Solenoid Pilot Valve

16 Serie Cylinders

Cilindros y accesorios

Cylinders and Accessories

17 Serie F.R.L

Componentes para el tratamiento del aire comprimido

Air treatment Units



NEW NEW

NEW

NEW NEW



EXCELENTES SOLUCIONES PARA EL AIRE COMPRIMIDO

Con más de 30 años de experiencia en el sector neumático, Aignep es un fabricante italiano líder en el mercado de elementos para el aire comprimido. Aignep es una empresa dinámica en el sector gracias a la perseverancia, la industrialización y las significativas inversiones realizadas por la familia Bugatti. Hoy en día Aignep consiste en una seria realidad industrial que cuenta con más de 150 trabajadores y una planta de producción de 22.000 metros cuadrados. Todos los productos son diseñados por un equipo profesional de ingenieros. La producción y el montaje son totalmente automatizados. Más de 10 millones de piezas listas para ser enviadas desde un revolucionario almacén automático que garantiza una entrega rápida. Distribución a nivel mundial a través de una amplia red de distribuidores fiables y 3 filiales en EE.UU., España e Suiza. 20 líneas de productos disponibles: racores automáticos, (serie 55000 de plástico, 50000 de latón anillo de plástico, 57000 totalmente metálica, 60000 inox, 70000 industria alimentaria, 58000 alta presión), racores rápidos (serie 1000), accesorios, válvulas de bola en miniatura (serie GHILUX), racores universales a bicono (serie 9.000-13.000), reguladores de flujo (serie Function), enchufes rápidos (serie enchufes rápidos), unidades de tratamiento de aire (FRL), cilindros neumáticos, tubería y espirales, INFINITY tubería y racores para redes de aire y muchos artículos especiales. Move the air Power!

“Excelentes soluciones para el aire comprimido, que nosotros garantizamos con un alto standard de tecnología, calidad y satisfacción del cliente”.

GRAZIANO BUGATTI
Director Gerente





EXCELLENT SOLUTIONS FOR COMPRESSED AIR

With more than 30 years experience in pneumatic field, Aignep is an Italian leading manufacturer of compressed air elements. Aignep is a dynamic player in the sector thanks to the perseverance, industriousness and significant investments of Bugatti family. Nowadays Aignep consists in a serious industrial reality which counts 150 workers on a production site of 22.000 sqm. All the products are designed by a professional team of engineers. The production and assembly are fully automated. More than 10 million parts ready to ship from a revolutionary automatic stock to guarantee quick delivery. Distribution worldwide through a wide network of reliable distributors and 3 branch offices in USA, Spain and Switzerland. 20 product lines available: automatic push-in fittings, (serie 55000 plastic, 50000 plastic-brass, 57000 full-brass, 60000 inox, 70000 food, 58000 high pressure), push-on fittings (serie 1000), accessories, miniature ball valves (serie GHILUX), universal ferrule fittings (serie 9000-13000), flow regulators (serie Fuction), quick couplings (serie Quick couplings), air treatment units (FRL), solenoid valves, pneumatic cylinders, tubes&spiral hoses, air pipeline INFINITY and many special items. Move the air Power!

"Excellent solutions for compressed air, that we grant with high technological standard , quality and customer satisfaction".

GRAZIANO BUGATTI
Managing Director



AIGNEP ITALIA

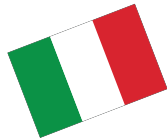

Via Don G. Bazzoli, 34 - 25070 Bione (BS)
T. +39 0365896626 - F. +39 0365896561
aignep@aignep.it - www.aignep.com

Sede Central



AIGNEP IBÉRICA



Pol. Ind. El Tortuguer "Can Prat", Naves 23 y 24
Tel. 93 828 47 36 - Fax 93 828 44 32
08691 MONISTROL DE MONTSERRAT (Barcelona)
www.aignep.es - e-mail: aignep@aignep.es



ALPHA TECHNOLOGIES U.S.A.



320 PREMIER CT #224
FRANKLIN, TN 37067
PH: 615-771-6650 - FX: 615-771-0926
www.alphafittings.com - e-mail: service@alphafittings.com



AIGNEP SWITZERLAND



AIGNEP AG - Römerstrasse 7 - CH-2555 Brügg - SCHWEIZ
T. + 41 32 342 09 09 - F. + 41 32 342 09 11
aignep.ch@aignep.com - www.aignep.com



- España · Portugal · Italia · Francia · Alemania · Reino Unido · Suiza · Austria · Grecia · Noruega · Suecia
Finlandia · Rusia · Turquía · Israel · Marruecos · Algeria · Tunisia · Egipto · Emiratos Arabes · Sur Africa · India
China · Corea del Sur · Japón · Taiwan · Australia · Singapur · Canada · Méjico · Estados Unidos
· Venezuela · Guatemala · Perú · Uruguay · Argentina · Brasil · Chile

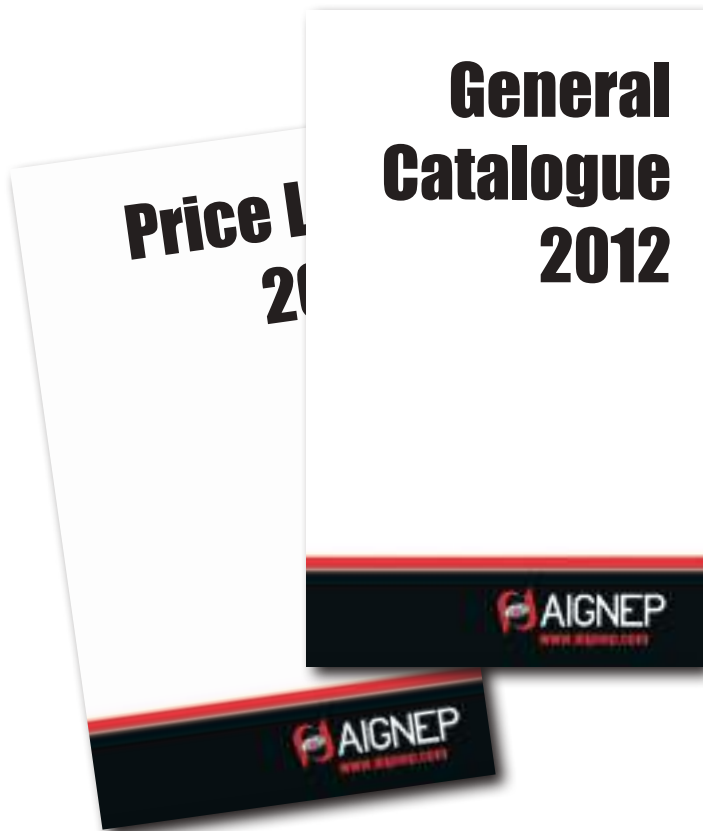

Catálogo General y Lista de precios 2012
General Catalogue and Price List 2012



Catálogo General y Lista de precios Infinity 2012
Infinity Catalogue and Price List 2012



Página Web:
www.aignep.com



CD-Rom
Catálogo 2012



Maletín EXPO 2012
Product Range



1 Serie 50000

Racordaje automático
Push-in Fittings



2 Serie 55000

Racordaje automático en tecnopolímero
Technopolymeric Push-in Fittings



3 Serie 57000

Racordaje automático con anillo metálico
Push-in Fittings with metal collet



4 Serie 70000

Racordaje automático food grade
Food Grade Push-in Fittings with metal collet



5 Serie Inox

Racordaje en acero inoxidable automático, rápido, accesorios y multipresa
Stainless steel Push-in Fittings, Push on fittings, Accessories and Multisocket



6 Serie 89000

Racordaje automático con anillo metálico para tubo en pulgadas
Push-in Fittings with metal collet and inch tube



7 Serie 58000

Racordaje automático para alta presión
High pressure push-in fittings



8 Serie 1000

Racordaje rápido
Push-on Fittings



9 Serie Function

Racordaje a funciones neumáticas
Function Fittings



10 Serie Ghilux

Válvulas a esfera
Ball Valves



11 Serie Accessories

Racordaje standard y portagoma
Fixtures and Fittings - Hose adapters
Racordaje con conexión a bayoneta
- Fittings with bayonet connection



12 Serie Tubes

Tubos en material plástico
Spiral and Tubes



13 Serie Quick Couplings

Enchufes rápidos, Enchufes de seguridad y Pistolas Sopladoras
Automatic Quick Couplings, Safety Couplings and Blow Guns



14 Serie Compression Fittings

Racordaje a Compresión
Compression Fittings



15 Serie Valves

Válvulas electroneumáticas, neumáticas y manuales
Manual, Pneumatic and Solenoid Pilot Valve



16 Serie Cylinders

Cilindros y accesorios
Cylinders and Accessories



17 Serie F.R.L

Componentes para el tratamiento del aire comprimido
Air treatment Units



SPECIAL ITEMS

Productos especiales bajo demanda
Product on demand

Serie 90000

Racordaje automático para las Redes de distribución de Aire Comprimido
Push-in fittings for pipeline installations

INFINITY **INFINITY LINE**

COMPRESSOR

**Solicita el Catálogo
Request Catalogue**







RoHS
compliant



Estas condiciones son aceptadas implícitamente por el comprador en el momento de ejecutar el pedido de compra.

1) PEDIDOS

Todos los pedidos, ya sean directamente enviados del vendedor como a través de agentes, representantes y auxiliares de comercio, siempre están sujetas a la aprobación del vendedor y no pueden ser revocados por el comprador.

2) DATOS TECNICOS

Pesos, tamaños, colores y otros datos que figuran en los catálogos, listas u otros documentos, son indicativos y no vinculantes. AIGNEP SPA se reserva el derecho de modificar en cualquier momento las especificaciones técnicas de los productos.

3) ENTREGA

Los términos de entrega son valores aproximados a favor del vendedor y con un margen razonable de tolerancia.

Salvo acuerdo contrario, las entregas de las mercancías serán Ex Works (Incoterms 2000), también cuando sea convenido en que el envío o parte de él, sea tratado por el vendedor, en el que este último actuará como agente del comprador, quedando entendido que el transporte se hará a costa y riesgo del comprador.

Los riesgos relacionados con la entregas pasan al comprador cuando las mercancías salen del establecimiento del vendedor.

El precio comprende el embalaje, siempre y cuando el comprador ordene las cantidades mínimas para cada uno de los artículos que figuran en el catálogo (PACKS).

El comprador está obligado siempre a aceptar la entrega de las mercancías, aun cuando las entregas sean parciales e incluso cuando las mercancías se entregan después de la fecha de entrega establecida.

Si el comprador no acepta la entrega de las mercancías, por razones no imputables al vendedor o de fuerza mayor, el comprador debe soportar todos los costes que pudieran derivarse de ellas, y cualquier suma adeudada a cualquier título para el vendedor se convertirá inmediatamente exigible.

4) GARANTÍA

El comprador está obligado a verificar la conformidad de la mercancía y la ausencia de defectos. Eventuales no conformes, errores cuantitativos o cualquier otra controversia sobre las mercancías deben ser denunciadas por el comprador, en un plazo menor a ocho días de la recepción de la mercancía.

Las quejas deben hacerse por escrito, especificando detalladamente los errores o la disconformidad de la mercancía en cuestión.

Como resultado ordinario de la reclamación por parte del comprador, el vendedor a su elección en un plazo razonable puede proporcionar productos libres al comprador equivalentes a los que se no reunían las condiciones requeridas, o acreditar una suma igual a la pagada por el comprador.

La garantía tiene una duración de 1 año a partir de la fecha de entrega.

La garantía a la que se refiere este artículo excluye cualquier otra posible responsabilidad del vendedor, incluidas las originadas por los productos suministrados. En ningún caso, el vendedor puede ser considerado responsable por daños indirectos, o consecuenciales, la pérdida de producción o de pérdida de beneficios.

5) PAGO

La factura de las mercancías suministradas debe ser pagada dentro de la fecha y el lugar acordados. La demora en el pago dará lugar a un efecto de los intereses atrasados y dar al vendedor el derecho de suspender los sucesivos suministros hasta el cumplimiento del pago.

6) RESERVA DE PROPIEDAD

Los productos entregados siguen siendo propiedad de AIGNEP hasta el momento de completar el pago.

7) CONTROVERSIAS

Para cualquier controversia relativa o vinculada al contrato en que se aplican las presentes condiciones generales será competencia exclusiva del Tribunal de la sede del vendedor: El vendedor, sin embargo, tiene el derecho de remitirlo al tribunal de la sede del comprador.

The present conditions are considered to be implicitly accepted by the buyer when he makes the purchase order.

1) ORDERS

Both direct orders and orders transmitted by agents, representatives or commercial auxiliaries of the seller do not bind him until they are confirmed by the seller himself: the buyer is not entitled to countermand its orders.

2) TECHNICAL DATA

Weights, dimensions, performances, colours and other information, indicated in catalogues price list, or other literature are merely indicative.

AIGNEP spa reserves the right at any time to make changes to its products technical specifications.

3) DELIVERY

The delivery terms are rough in favour of the seller and in any event, are to be considered with an adequate term of grace. The supply of the goods is intended ex works (Incoterms 2000), also when it is agreed that the delivery or part of it will be taken care of by the seller, in which case the latter will act as the buyer's agent, it being understood that the transport will be carried out at the charge and risk of the buyer.

The risks related to the supply pass to the buyer at the time in which the goods leave the seller's plant.

Packing is included in the price only when the buyer orders, for each item, the minimum quantity indicated in the catalogue.

The buyer binds himself to take delivery of the goods, even in the case of partial deliveries and even when the goods are consigned after the established delivery date or successively to that date.

If the buyer does not take delivery of the goods for reasons not imputable to the seller or force majeure, the buyer must bear all the expenses that may derive from them and any sum due, by any right, to the seller will become immediately payable.

4) GUARANTEE

The buyer is obliged to check the conformity of the goods and the lack of defects. Any non-conformity lack in quantity or any other complaint about the delivery goods must be notified by the buyer, under penalty of cancellation of the guarantee, not later than 8 days from the receipt of the goods.

Any claim must be made in writing and must give a detailed account of the defects or non-conformity of the goods in question. Following a claim placed by the buyer according to the procedures detailed in this clause, within reasonable period considering the extent of the claim the seller may (at his choice): supply free to the buyer, ex works goods of equivalent quality to replace the defective goods or credit an amount equal to what was paid by the buyer.

The guarantee is valid for 1 year from the deliver date.

The guarantee contained in this article excludes any other possible liability of the seller, however originating, from the supplied goods. In no case will the seller be held responsible for indirect or consequential damages, losses of production or profits.

5) PAYMENT

Any invoice referring to the delivered goods is to be paid according to the terms and in the place agreed. Any delay in payment will entitle the seller to legal interests, with no prejudice to his right to suspend the current supplies till full payment is duly received.

6) RESERVATION OF TITLE

Title to the shall not pass to the Buyer until AIGNEP spa has received all amounts due and payable by the Buyer.

7) DISPUTES

For every dispute relative or, in any event connected to the contracts to which the present general conditions apply, the seller's law-court has exclusive competence: the seller however, will have the authority to act before the buyer's lawcourt.



Serie 50000

RACORDAJE AUTOMÁTICO
PUSH-IN FITTINGS

Características técnicas / Technical Characteristics

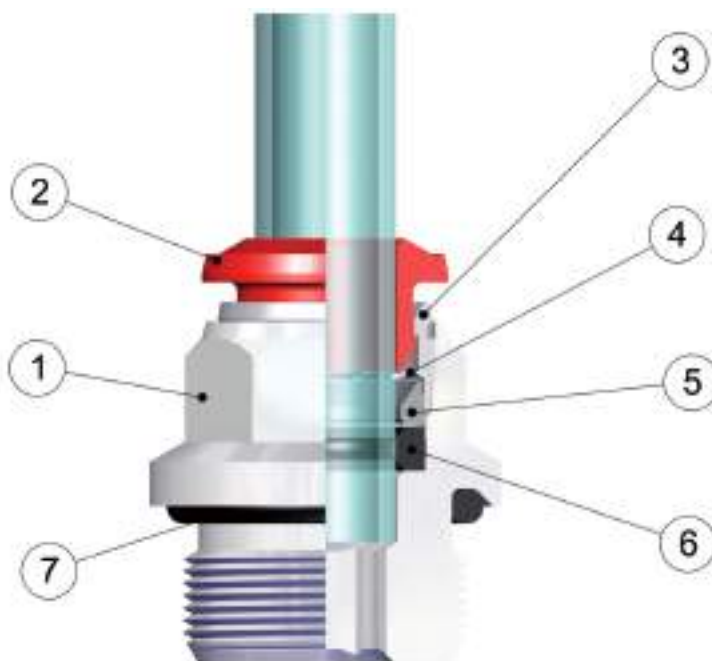

Materiales y componentes / Component Parts and Materials

1 Cuerpo en latón niquelado	1 Nickel-plated brass Body
2 Anillo de extracción tubo en resina acetálica	2 Acetalic resin Collet
3 Cápsula en latón niquelado	3 Nickel-plated brass Capsule
4 Pinza de agarre en acero inox aisi 301	4 Steel aisi 301 Clamping washer
5 Anillo de seguridad en tecnopolímero	5 Technopolymeric Safety ring
6 Junta de labio en NBR	6 Nbr Lip seal
7 Junta rosca en NBR	7 Nbr Thread packing

Presiones / Pressures

Presión mínima / Minimum pressure: **-0.99 bar (-0.099 MPa)**
 Presión máxima / Maximum pressure: **15 bar (1.5 MPa)**

Temperaturas / Temperatures

Temperatura mínima / Minimum temperature: **-20 °C**
 Temperatura máxima / Maximum temperature: **+80 °C**

Roscas / Threads

Gas cónica "short" / "Short" Tapered thread.
 Gas cónica conforme ISO 7.1, BS 21, DIN 2999 / Tapered gas in conformity with ISO 7.1, BS 21, DIN 2999.
 Gas cilíndrica conforme ISO 228 Clase A / Parallel gas in conformity with ISO 228 Class A.
 Métrica conforme ISO R/262 / Metric in conformity with ISO R/262.

Tubos de conexión / Connection Tubes

Tubos en material plástico:
PA6, PA11, PA 12, Polietileno, *Poliuretano; etc.
 *Para tubos en poliuretano es aconsejada una dureza de 98 shore.
 Plastic tubes:
 PA6, PA11, PA12, Polyethylene, *Polyurethane, ecc.
 *For Polyurethane hoses it is required a minimum hardness of 98 shore.

Fluidos compatibles / Fluids

Aire comprimido / Compressed air.
Vacío / Vacuum

Rosca / Threads

La rosca cónica "short" ha sido proyectada para satisfacer las siguientes características:

- reducir la longitud
- reducir la llave respecto a algunos racores con rosca cilíndrica
- consentir el acoplamiento con diferentes standard de roscas hembra sean cónicas o cilíndricas

The "short" taper thread has been designed to offer the following advantages to the users:

- reduced overall length;
- smaller hex dimensions compared to the parallel threads;
- to allow the assembly with different female threads both taper as well as parallel;



Consentir una completa estanqueidad incluso en superficies no perfectamente planas, cóncavas, convexas o inclinadas, con diferentes ángulos o radios. To ensure the right tightening also with surfaces not perfectly flat, without spot-facing, concave convex and with different kinds of chamfers or radius.



Inclinada
Inclined



Cóncava
Concave



Convexa
Convex

Par de apriete / Torque specifications



PAR DE APRIETE PARA ROSCAS MACHO ISO 228 CON TÓRICA
TORQUE TO MALE THREADS ISO-228 WITH OR

MEDIDA MEASURE	PAR ACONSEJADO Nm RECOMMENDED TORQUE Nm	PAR DE ROTURA Nm BREAKING TORQUE Nm
M5	0,08	0,32
1/8	3	8
1/4	9	30
3/8	10	60
1/2	12	50

LOS VALORES DE ROTURA PUEDEN VARIAR EN FUNCIÓN DEL ARTÍCULO
BREAKING VALUES MAY VARY ACCORDING TO THE ITEM



PAR DE APRIETE PARA ROSCAS MACHO "SHORT"
TORQUE TO MALE THREADS "SHORT"

MEDIDA MEASURE	PAR MÍNIMO ACONSEJADO Nm RECOMMENDED MINIMUM TORQUE Nm	PAR MÁXIMO ACONSEJADO Nm RECOMMENDED MAX TORQUE Nm
1/8	5	7
1/4	5	7
3/8	5	7
1/2	5	7

LOS VALORES DE ROTURA PUEDEN VARIAR EN FUNCIÓN DEL ARTÍCULO
BREAKING VALUES MAY VARY ACCORDING TO THE ITEM

Todas las roscas de esta serie (incluyendo la medida de M5) están fabricadas con junta de cierre que permite la inmediata utilización del racor reduciendo notablemente el tiempo de instalación.

All of threads from this range (also the M5), have been equipped with tightening parts which allow the direct assembly of the fittings, reducing the installation time.

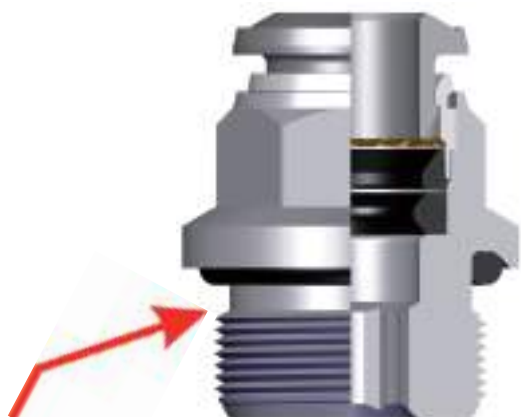

**Junta tórica (O-Ring)
para roscas cilíndricas**
*O-Ring for the parallel
threads.*

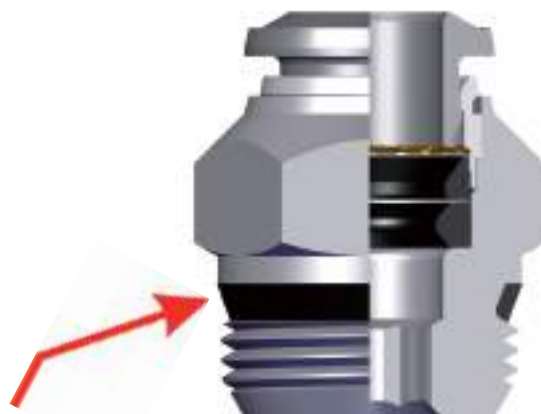

**Junta de cierre para
roscas cónicas "short"**
*Thread packing for the
taper threads.*



Todos los racores rectos, con roscas cónicas o cilíndricas, pueden montarse también con llave hexagonal y es posible utilizarlos incluso en espacios muy reducidos.

All the straight fittings, with taper and parallel threads can be assembled also with Allen wrench and it is possible to use them in reduced spaces.

Pinza de sujeción / Clamping washer

La pinza en acero inox garantiza el perfecto agarre del tubo de cualquier material sin perjudicar la superficie.

The collet made in stainless steel ensure the perfect tube clamping with every kinds of materials without damage the surface.

La conexión entre tubo y racor asegura una estanqueidad total aun en condiciones de impacto o vibración.

The connection between the tube and the fitting ensure a total tightness even in severe conditions such as impact and vibrations.

La particular geometría de la junta garantiza una perfecta estanqueidad incluso en vacío.

The particular geometric shape of the seal ensure the perfect tightness even with vacuum.



50000

RACOR RECTO MACHO CÓNICO (SHORT) - STRAIGHT MALE ADAPTOR (SHORT)

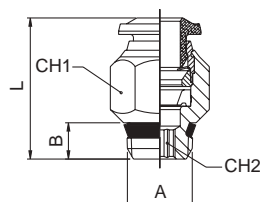

Código Code	Tubo Tube	A	B	L	CH1	CH2	Conf. Pack.
500000001	4	1/8	5.5	18	11	3	10
500000013	4	1/4	7	19	14	3	10
500000011	5	1/8	5.5	20	11	4	10
500000012	5	1/4	7	20	14	4	10
500000002	6	1/8	5.5	21.5	13	4	10
500000003	6	1/4	7	21	14	4	10
500000014	6	3/8	7.5	23	17	4	10
500000015	6	1/2	9	23.5	21	4	10
500000004	8	1/8	5.5	24.5	14	5	10
500000005	8	1/4	7	22	14	6	10
500000006	8	3/8	7.5	23	17	6	10
500000016	8	1/2	9	23.5	21	6	10
500000007	10	1/4	7	28	17	7	10
500000008	10	3/8	7.5	25.5	17	8	10
500000017	10	1/2	9	26	21	8	10
500000009	12	1/4	7	31.5	20	7	10
500000010	12	3/8	7.5	29.5	20	9	10
500000018	12	1/2	9	31.5	21	10	10
500000019	14	3/8	7.5	32.5	21	9	10
500000020	14	1/2	9	31.5	21	10	10

50010

RACOR RECTO MACHO CÓNICO (SHORT) HEXÁGONO INTERIOR - STRAIGHT MALE ADAPTOR (SHORT) WITH EXAGON EMBEDDED

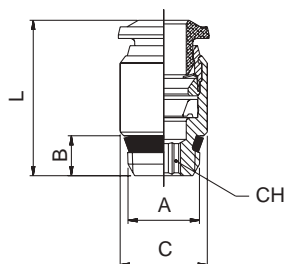

Código Code	Tubo Tube	A	B	C	L	CH	Conf. Pack.
500100008	3	M5	4	8	19	2.5	10
500100001	4	M5	4	9.5	19.5	2.5	10
500100002	4	1/8	5.5	11	18	3	10
500100009	4	M7x1	5	10	21	2.5	10
500100007	6	M5	4	12	24.5	2.5	10
500100003	6	1/8	5.5	12	21.5	4	10
500100004	6	1/4	7	14	21	4	10
500100005	8	1/8	5.5	14	25	5	10
500100006	8	1/4	7	14	22.5	6	10

50020

RACOR RECTO MACHO CILÍNDRICO CON TÓRICA - STRAIGHT MALE ADAPTOR (PARALLEL)

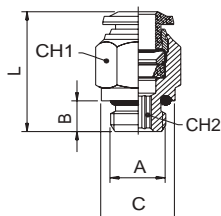

Código Code	Tubo Tube	A	B	C	L	CH1	CH2	Conf. Pack.
500200021	3	M5	4	8	19	8	2	10
500200001	4	M5	4	8	21	10	2	10
500200002	4	1/8	6	13	20	10	3	10
500200022	4	1/4	8	16	19.5	16	3	10
500200018	5	M5	4	8	23.5	12	2	10
500200019	5	1/8	6	13	22	12	4	10
500200020	6	M5	4	10	24.5	13	2	10
500200003	6	1/8	6	13	23.5	13	4	10
500200004	6	1/4	8	16	23.5	13	4	10
500200027	6	3/8	9	20	25	13	4	10
500200028	6	1/2	10	25	27	13	4	10
500200005	8	1/8	6	13	25	14	5	10
500200006	8	1/4	8	16	23	14	6	10
500200007	8	3/8	9	20	24	14	6	10
500200029	8	1/2	10	25	26.5	14	6	10
500200008	10	1/4	8	16	30.5	17	6	10
500200009	10	3/8	9	20	27.5	17	8	10
500200031	10	1/2	10	25	27	17	8	10
500200032	12	1/4	8	16	34.5	20	6	10
500200011	12	3/8	9	20	34	20	8	10
500200023	12	1/2	10	25	31	22	10	10
500200024	14	3/8	9	20	35	21	10	10
500200025	14	1/2	10	25	32	22	10	10
500200012	6	M12x1	8	15	23.5	13	4	10
500200013	6	M12x1.25	8	15	23.5	13	4	10
500200014	6	M12x1.5	8	15	23.5	13	4	10
500200017	8	M12x1.5	8	15	27.5	14	6	10

50030

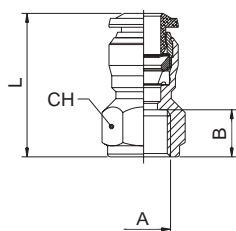
RACOR RECTO HEMBRA - STRAIGHT FEMALE ADAPTOR

Código Code	Tubo Tube	A	B	L	CH	Conf. Pack.
5003000007	3	M5	5,5	18,5	9	10
5003000008	4	M5	5,5	21	11	10
5003000001	4	1/8	8,5	24	13	10
5003000009	4	1/4	11	27,5	16	10
5003000006	5	1/8	8,5	26,5	13	10
5003000002	6	1/8	8,5	26	13	10
5003000003	6	1/4	11	29,5	16	10
5003000004	8	1/8	8,5	27	15	10
5003000005	8	1/4	11	29,5	17	10
5003000010	8	3/8	12	32	19	10
5003000011	10	1/4	11	32	18	10
5003000012	10	3/8	12	33,5	19	10
5003000013	10	1/2	15	39	24	10
5003000014	12	3/8	12	36	21	10
5003000015	12	1/2	15	41	24	10

50040

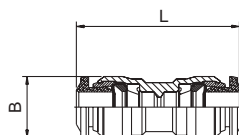
RACOR RECTO INTERMEDIO - STRAIGHT CONNECTOR

Código Code	Tubo Tube	L	B	Conf. Pack.	
5004000009	3	26	8,5	10	
5004000001	4	30,5	10,5	10	
5004000008	5	33	11,5	10	
5004000002	6	4	32	12,5	10
5004000003	6	34	12,5	10	
5004000004	8	6	35	14,5	10
5004000005	8	36	14,5	10	
5004000011	10	8	40,5	17,5	10
5004000006	10	42	17,5	10	
5004000012	12	10	45,5	20,5	10
5004000007	12	47	20,5	10	
5004000010	14	49	21,5	10	

50050

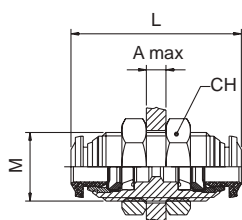
RACOR RECTO INTERMEDIO PASATABIQUES - BULKHEAD CONNECTOR

Código Code	Tubo Tube	M	L	CH	A max	Conf. Pack.
5005000007	3	M10x1	26	14	5	10
5005000001	4	M12x1	31,5	17	7	10
5005000006	5	M14x1	33	17	7	10
5005000002	6	M14x1	35	17	9,5	10
5005000003	8	M16x1	37	19	10,5	10
5005000004	10	M20x1	43	24	12,5	10
5005000005	12	M22x1	48	26	16,5	10

50100

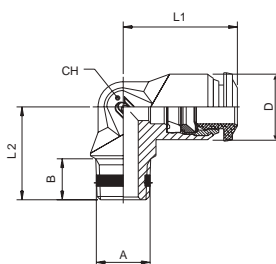
RACOR A L MACHO CÓNICO - ELBOW MALE ADAPTOR (TAPER)

Código Code	Tubo Tube	A	B	L1	L2	CH	D	Conf. Pack.
5010000001	4	M5	5	17	15	9	10	10
5010000002	4	1/8	7,5	17	15,5	9	10	10
5010000010	5	M5	5	20	17	11	12,5	10
5010000011	5	1/8	7,5	20	17,5	11	12,5	10
5010000003	6	1/8	7,5	21	17,5	11	12,5	10
5010000012	6	1/4	11	21	21,5	11	12,5	10
5010000004	8	1/8	7,5	22,5	19	13	14	10
5010000005	8	1/4	11	22,5	21,5	13	14	10
5010000006	10	1/4	11	26,5	24,5	16	17	10
5010000007	10	3/8	11,5	26,5	24	16	17	10
5010000008	12	1/4	11	30,5	28	19	21,5	10
5010000009	12	3/8	11,5	30,5	28	19	21,5	10

50106

RACOR A L ORIENTABLE HEMBRA - ORIENTING ELBOW FEMALE ADAPTOR

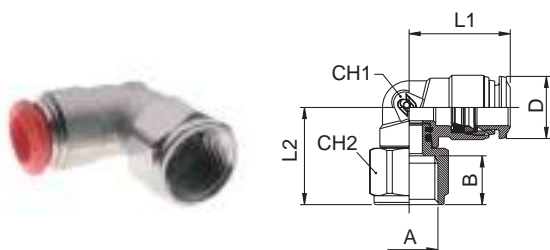

Código Code	Tubo Tube	A	B	L1	L2	CH1	CH2	D	Conf. Pack.
501060001	4	- 1/8	8.5	18	20	9	13	10	10
501060002	4	- 1/4	11	18	21.5	9	16	10	10
501060003	6	- 1/8	8.5	21	20.5	11	13	12.5	10
501060004	6	- 1/4	11	21	23	11	16	12.5	10
501060005	8	- 1/8	8.5	22.5	22	12	13	14.5	10
501060006	8	- 1/4	11	22.5	24.5	12	16	14.5	10

50111

RACOR A L ORIENTABLE MACHO CÓNICO (SHORT) - ORIENTING ELBOW MALE ADAPTOR (SHORT)

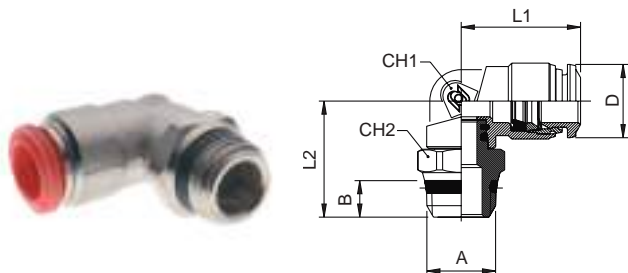

Código Code	Tubo Tube	A	B	L1	L2	CH	CH2	D	Conf. Pack.
501110001	4	1/8	5.5	18	19.5	9	13	10	10
501110002	4	1/4	7	18	21	9	15	10	10
501110003	5	1/8	5.5	20	21.5	11	13	12.5	10
501110004	6	1/8	5.5	21	21.5	11	13	12.5	10
501110005	6	1/4	7	21	23	11	15	12.5	10
501110006	8	1/8	5.5	22.5	24	12	13	14.5	10
501110007	8	1/4	7	22.5	24	12	15	14.5	10
501110008	8	3/8	7.5	22.5	24.5	12	17	14.5	10
501110009	8	1/2	9	22.5	27	12	21	14.5	10
501110010	10	1/4	7	26.5	26.5	14	16	17.5	10
501110011	10	3/8	7.5	26.5	24.5	14	17	17.5	10
501110012	10	1/2	9	26.5	27	14	21	17.5	10
501110013	12	3/8	7.5	31.5	26.5	16	20	21.5	10
501110014	12	1/2	9	31.5	29	16	21	21.5	10
501110015	14	3/8	7.5	31.5	27	16	20	21.5	10
501110016	14	1/2	9	31.5	29.5	16	21	21.5	10

50116

RACOR A L ORIENTABLE MACHO CILÍNDRICO CON TÓRICA - ORIENTING ELBOW MALE ADAPTOR (PARALLEL)

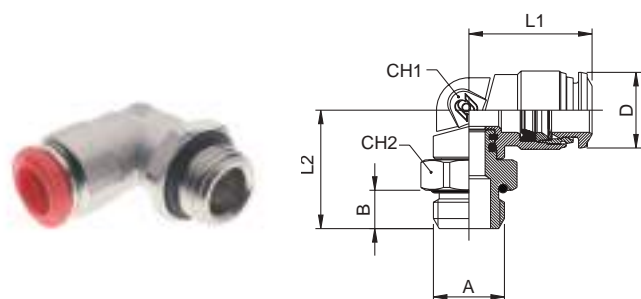

Código Code	Tubo Tube	A	B	L1	L2	CH1	CH2	D	Conf. Pack.
501160001	3	M5	3.5	16.5	17.5	9	8	10	10
501160002	4	M5	3.5	18	17.5	9	8	10	10
501160003	4	1/8	5.5	18	18	9	13	10	10
501160004	4	1/4	7	18	18	9	16	10	10
501160005	5	M5	3.5	20	20	11	11	12.5	10
501160006	5	1/8	5.5	20	20	11	13	12.5	10
501160007	6	M5	3.5	21	20	11	11	12.5	10
501160008	6	1/8	5.5	21	20	11	13	12.5	10
501160009	6	1/4	7	21	21.5	11	16	12.5	10
501160010	8	1/8	5.5	22.5	22.5	12	13	14.5	10
501160011	8	1/4	7	22.5	23	12	16	14.5	10
501160012	8	3/8	8	22.5	25	12	20	14.5	25
501160013	8	1/2	9.5	22.5	26.5	12	25	14.5	10
501160014	10	1/4	7	26.5	25.5	14	16	17.5	10
501160015	10	3/8	8	26.5	25	14	20	17.5	10
501160016	10	1/2	9.5	26.5	26.5	14	25	17.5	10
501160025	12	1/4	8	31.5	27.5	16	20	21.5	10
501160017	12	3/8	8	31.5	27	16	20	21.5	10
501160018	12	1/2	9.5	31.5	28.5	16	25	21.5	10
501160019	14	3/8	8	31.5	27.5	16	20	21.5	10
501160020	14	1/2	9.5	31.5	29	16	25	21.5	10
501160021	6	M12x1	7.5	20	22	11	16	12.5	10
501160022	6	M12x1.25	7.5	20	22	11	16	12.5	10
501160023	6	M12x1.5	7.5	20	22	11	16	12.5	10
501160024	8	M12x1.5	7.5	22.5	23.5	12	16	14.5	10

50121

RACOR A L ORIENTABLE PROLONGADO MACHO CÓNICO (SHORT) - EXTENDED ORIENTING ELBOW MALE ADAPTOR (SHORT)

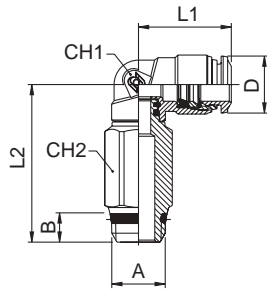

Código Code	Tubo Tube	A	B	L1	L2	CH1	CH2	D	Conf. Pack.
5012100001	4	1/8	5.5	18	31.5	9	12	10	10
5012100002	4	1/4	7	18	33	9	15	10	10
5012100003	5	1/8	5.5	20	36	11	12	12.5	10
5012100004	6	1/8	5.5	21	36	11	12	12.5	10
5012100005	6	1/4	7	21	37.5	11	15	12.5	10
5012100006	8	1/8	5.5	22.5	40.5	12	12	14.5	10
5012100007	8	1/4	7	22.5	40.5	12	15	14.5	10
5012100008	8	3/8	7.5	22.5	41	12	16	14.5	10
5012100009	10	1/4	7	26.5	46	14	15	17.5	10
5012100010	10	3/8	7.5	26.5	44	14	17	17.5	10

50126

RACOR A L ORIENTABLE PROLONGADO MACHO CILÍNDRICO CON TÓRICA - EXTENDED ORIENTING ELBOW MALE ADAPTOR (PARALLEL)

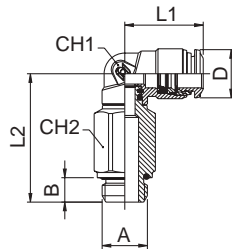

Código Code	Tubo Tube	A	B	L1	L2	CH1	CH2	D	Conf. Pack.
5012600001	4	1/8	5.5	18	30	9	12	10	10
5012600002	4	1/4	7	18	32	9	15	10	10
5012600003	5	1/8	5.5	20	34.5	11	12	12.5	10
5012600004	6	1/8	5.5	21	34.5	11	12	12.5	10
5012600005	6	1/4	7	21	36	11	15	12.5	10
5012600006	8	1/8	5	23	39	12	12	14.5	10
5012600007	8	1/4	7	22.5	39.5	12	15	14.5	10
5012600008	8	3/8	8	22.5	41.5	12	18	14.5	10
5012600009	10	1/4	7	26.5	45	14	16	17.5	10
5012600010	10	3/8	8	26.5	44.5	14	18	17.5	10

50130

RACOR A L INTERMEDIO - ELBOW CONNECTOR

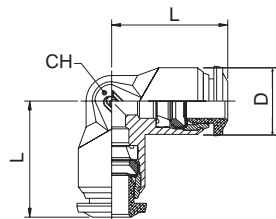

Código Code	Tubo Tube	L	CH	D	Conf. Pack.
5013000007	3	17	9	10	10
5013000001	4	17	9	10	10
5013000006	5	20	11	12.5	10
5013000002	6	21	11	12.5	10
5013000003	8	22.5	13	14	10
5013000004	10	26.5	16	17	10
5013000005	12	30.5	19	21.5	10
5013000008	14	32.5	19	21.5	10

50200

RACOR A T MACHO CENTRAL CÓNICO - TEE MALE ADAPTOR (TAPER) - CENTRE LEG

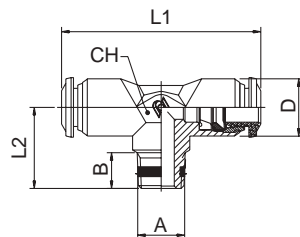

Código Code	Tubo Tube	A	B	L1	L2	CH	D	Conf. Pack.
5020000001	4 - M5	5	34	15	9	10	10	10
5020000002	4 - 1/8	7.5	34	15.5	9	10	10	10
5020000010	5 - 1/8	7.5	40	17.5	11	12.5	10	10
5020000003	6 - 1/8	7.5	42	17.5	11	12.5	10	10
5020000004	8 - 1/8	7.5	45	19	13	14	10	10
5020000005	8 - 1/4	11	45	21.5	13	14	10	10
5020000006	10 - 1/4	11	53	24.5	16	17	10	10
5020000007	10 - 3/8	11.5	53	24	16	17	10	10
5020000008	12 - 1/4	11	61	28	19	21.5	10	10
5020000009	12 - 3/8	11.5	61	28	19	21.5	10	10

50211

RACOR A T ORIENTABLE MACHO CENTRAL CÓNICO (SHORT) - ORIENTING TEE MALE ADAPTOR (SHORT) - CENTRE LEG

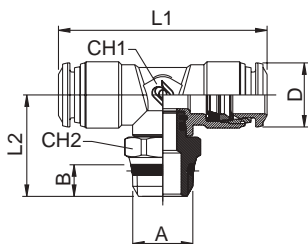

Código Code	Tubo Tube	A	B	L1	L2	CH1	CH2	D	Conf. Pack.
5021100001	4	1/8	5.5	34	20	9	13	10	10
5021100002	4	1/4	7	34	21.5	9	15	10	10
5021100003	5	1/8	5.5	40	22	11	13	12.5	10
5021100004	6	1/8	5.5	42	22	11	13	12.5	10
5021100005	6	1/4	7	42	23.5	11	15	12.5	10
5021100006	8	1/8	5.5	45	25.5	13	13	14.5	10
5021100007	8	1/4	7	45	25.5	13	15	14.5	10
5021100008	8	3/8	7.5	45	26	13	17	14.5	10
5021100009	8	1/2	9	45	28.5	13	21	14.5	10
5021100010	10	1/4	7	53	29	14	16	17.5	10
5021100011	10	3/8	7.5	53	27	14	17	17.5	10
5021100012	10	1/2	9	53	29.5	14	21	17.5	10
5021100013	12	3/8	7.5	62.6	29.5	16	20	21.5	10
5021100014	12	1/2	9	62.6	32	16	21	21.5	10
5021100015	14	3/8	7.5	62.6	29.5	16	20	21.5	10
5021100016	14	1/2	9	62.6	32	16	21	21.5	10

50216

RACOR A T ORIENTABLE MACHO CENTRAL CILÍNDRICO CON TÓRICA - ORIENTING TEE MALE ADAPTOR (PARALLEL) - CENTRE LEG

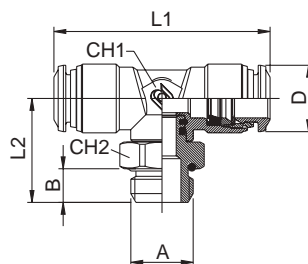

Código Code	Tubo Tube	A	B	L1	L2	CH1	CH2	D	Conf. Pack.
5021600001	3	M5	3.5	33	17	9	8	10	10
5021600002	4	M5	3.5	34	18	9	8	10	10
5021600003	4	1/8	5.5	34	18.5	9	13	10	10
5021600004	4	1/4	7	34	20	9	16	10	10
5021600005	5	M5	3.5	40	20.5	11	11	12.5	10
5021600006	5	1/8	5.5	40	20.5	11	13	12.5	10
5021600007	6	M5	3.5	42	20.5	11	11	12.5	10
5021600008	6	1/8	5.5	42	20.5	11	13	12.5	10
5021600009	6	1/4	7	42	22	11	16	12.5	10
5021600010	8	1/8	5.5	45	23.5	13	13	14.5	10
5021600011	8	1/4	7	45	24	13	16	14.5	10
5021600012	8	3/8	8	45	26	13	20	14.5	10
5021600013	8	1/2	9.5	45	27.5	13	25	14.5	10
5021600014	10	1/4	7	53	27.5	14	16	17.5	10
5021600015	10	3/8	8	53	27	14	20	17.5	10
5021600016	10	1/2	9.5	53	28.5	14	25	17.5	10
5021600017	12	3/8	8	62.5	29.5	16	20	21.5	10
5021600018	12	1/2	9.5	62.5	31	16	25	21.5	10
5021600019	14	3/8	8	62.5	29.5	16	20	21.5	10
5021600020	14	1/2	9.5	62.5	31	16	25	21.5	10
5021600021	6	M12x1	7.5	42	22	11	16	12.5	10
5021600022	6	M12x1.25	7.5	42	22	11	16	12.5	10
5021600023	6	M12x1.5	7.5	42	22	11	16	12.5	10

50223

RACOR A T ORIENTABLE MACHO LATERAL CÓNICO (SHORT) - ORIENTING TEE MALE ADAPTOR (SHORT) OFF - SET LEG

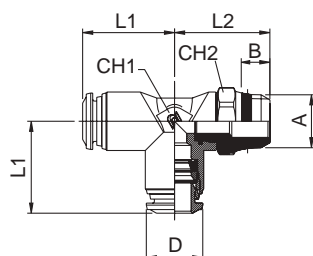

Código Code	Tubo Tube	A	B	L1	L2	CH1	CH2	D	Conf. Pack.
5022300001	4	1/8	5.5	17	20	9	13	10	10
5022300002	4	1/4	7	17	21.5	9	15	10	10
5022300003	5	1/8	5.5	20	22	11	13	12.5	10
5022300004	6	1/8	5.5	21	22	11	13	12.5	10
5022300005	6	1/4	7	21	23.5	11	15	12.5	10
5022300006	8	1/8	5.5	22.5	25	13	13	14.5	10
5022300007	8	1/4	7	22.5	25	13	15	14.5	10
5022300008	8	3/8	7.5	22.5	28	13	17	14.5	10
5022300009	8	1/2	9	22.5	28	13	21	14.5	10
5022300010	10	1/4	7	26.5	26	14	16	17.5	10
5022300011	10	3/8	7.5	26.5	26	14	17	17.5	10
5022300012	10	1/2	9	26.5	28.5	14	21	17.5	10
5022300013	12	3/8	7.5	31.5	29.5	16	20	21.5	10
5022300014	12	1/2	9	31.5	32	16	21	21.5	10

50226

RACOR A T ORIENTABLE MACHO LATERAL CILÍNDRICO CON TÓRICA - ORIENTING TEE MALE ADAPTOR (PARALLEL) OFF - SET LEG

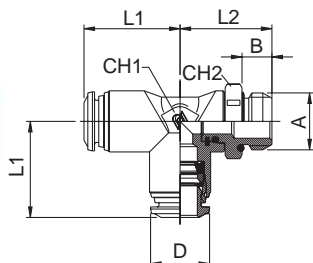

Código Code	Tubo Tube	A	B	L1	L2	CH1	CH2	D	Conf. Pack.
5022600001	3	M5	3.5	16.5	17	9	8	10	10
5022600002	4	M5	3.5	17	18	9	8	10	10
5022600003	4	1/8	5.5	17	18.5	9	13	10	10
5022600004	4	1/4	7	17	20	9	16	10	10
5022600005	5	M5	3.5	20	20.5	11	11	12.5	10
5022600006	5	1/8	5.5	20	20.5	11	13	12.5	10
5022600007	6	M5	3.5	21	20.5	11	11	12.5	10
5022600008	6	1/8	5.5	21	20.5	11	13	12.5	10
5022600009	6	1/4	7	21	22	11	16	12.5	10
5022600010	8	1/8	5.5	22.5	22.5	13	13	14.5	10
5022600011	8	1/4	7	22.5	24	13	16	14.5	10
5022600012	8	3/8	8	22.5	26	13	20	14.5	10
5022600013	8	1/2	9.5	22.5	27.5	13	25	14.5	10
5022600014	10	1/4	7	26.5	27	14	16	17.5	10
5022600015	10	3/8	8	26.5	26.5	14	20	17.5	10
5022600016	10	1/2	9.5	26.5	28	14	25	17.5	10
5022600017	12	3/8	8	31.5	29.5	16	20	21.5	10
5022600018	12	1/2	9.5	31.5	31	16	25	21.5	10
5022600021	6	M12x1	7.5	21	22	11	16	12.5	10
5022600022	6	M12x1.25	7.5	21	22	11	16	12.5	10
5022600023	6	M12x1.5	7.5	21	22	11	16	12.5	10

50230

RACOR A T INTERMEDIO - TEE CONNECTOR

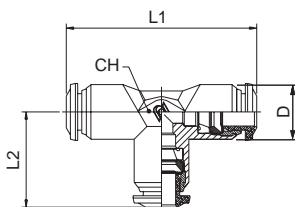

Código Code	Tubo Tube	L1	L2	CH	D	Conf. Pack.
5023000007	3	34	17	9	10	10
5023000001	4	34	17	9	10	10
5023000006	5	40	20	11	12.5	10
5023000002	6	42	21	11	12.5	10
5023000003	8	45	22.5	13	14	10
5023000004	10	53	26.5	16	17	10
5023000005	12	61	30.5	19	21.5	10
5023000008	14	65.5	32.5	19	21.5	10

50310

RACOR A Y INTERMEDIO - Y CONNECTOR

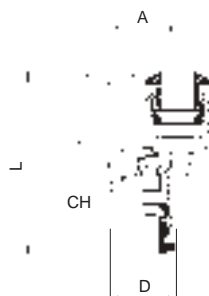

Código Code	Tubo Tube	A	L	CH	D	Conf. Pack.
5031000007	3	10	29	11	10	10
5031000001	4	11	32	11	10	10
5031000004	5	13.5	35	13	12.5	10
5031000002	6	13.5	36.5	13	12.5	10
5031000003	8	15.5	41	15	14	10
5031000008	10	18.5	48	18	17	10

50500

ANILLO ORIENTABLE SIMPLE - SINGLE BANJO BODY



Código Code	Tubo Tube	A	B	L	CH	D	Conf. Pack.
5050000019	3	M5	12.5	19	-	10	10
5050000020	3	M6	12.5	19	-	10	10
5050000001	4	M5	12.5	19	-	10	10
5050000002	4	M6	12.5	19	-	10	10
5050000003	4	1/8	15	21	14	10	10
5050000013	5	M5	12.5	20	-	12.5	10
5050000017	5	M6	12.5	20	-	12.5	10
5050000014	5	1/8	15	21.5	14	12.5	10
5050000015	5	1/4	17	24.5	18	12.5	10
5050000016	6	M5	12.5	20.5	-	12.5	10
5050000018	6	M6	12.5	20.5	-	12.5	10
5050000004	6	1/8	15	22	14	12.5	10
5050000005	6	1/4	17	25	18	12.5	10
5050000006	8	1/8	15	24	14	14	10
5050000007	8	1/4	17	26	18	14	10
5050000008	8	3/8	20	28	21	14	10
5050000009	10	1/4	17	29	18	17	10
5050000010	10	3/8	20	30.5	21	17	10
5050000012	12	3/8	20	32.5	21	21.5	10
5050000021	12	1/2	24	35	25	21.5	10
5050000022	14	1/2	24	35.5	25	21.5	10

50510

ANILLO ORIENTABLE DOBLE - DOUBLE BANJO BODY



Código Code	Tubo Tube	A	B	L	CH	D	Conf. Pack.
5051000001	4	M5	12.5	38	-	10	10
5051000002	4	M6	12.5	38	-	10	10
5051000003	4	1/8	15	42	14	10	10
5051000008	5	1/8	15	43	14	12.5	10
5051000009	5	1/4	17	49	18	12.5	10
5051000004	6	1/8	15	44	14	12.5	10
5051000005	6	1/4	17	50	18	12.5	10
5051000006	8	1/8	15	48	14	14	10
5051000007	8	1/4	17	52	18	14	10

50550

RACOR ORIENTABLE SIMPLE CON TÓRICA - ORIENTING SINGLE BANJO BODY MALE

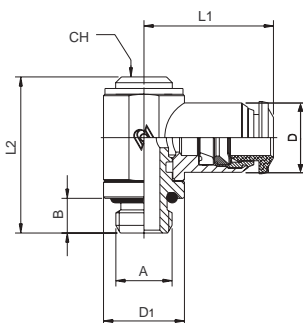

Código Code	Tubo Tube	A	B	L1	L2	CH	D1	D	Conf. Pack.
5055000001	4	M5	3.6	19	24.5	-	CH8	10	10
5055000002	4	1/8	6	21	28	5	14	10	10
5055000012	5	M5	3.6	20	24.5	-	CH8	12.5	10
5055000013	5	1/8	6	21.5	28	5	14	12.5	10
5055000014	5	1/4	8	24.5	31	6	18	12.5	10
5055000015	6	M5	3.6	20.5	24.5	-	CH8	12.5	10
5055000003	6	1/8	6	22.5	28	5	14	12.5	10
5055000004	6	1/4	8	25	31	6	18	12.5	10
5055000005	8	1/8	6	24	28	5	14	14	10
5055000006	8	1/4	8	26	31	6	18	14	10
5055000007	8	3/8	9	28	35.5	7	21	14	10
5055000008	10	1/4	8	29	31	6	18	17	10
5055000009	10	3/8	9	30.5	35.5	7	21	17	10
5055000011	12	3/8	9	32.5	35.5	7	21	21.5	10

50560

RACOR ORIENTABLE DOBLE CON TÓRICA - ORIENTING DOUBLE BANJO BODY MALE

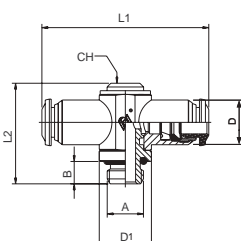

Código Code	Tubo Tube	A	B	L1	L2	D1	CH	D	Conf. Pack.
5056000002	4	1/8	6	42	27	14	5	10	10
5056000008	5	1/8	6	43	27	14	5	12.5	10
5056000009	5	1/4	8	49	31	18	6	12.5	10
5056000003	6	1/8	6	45	27	14	5	12.5	10
5056000004	6	1/4	8	50	31	18	6	12.5	10
5056000005	8	1/8	6	48	27	14	5	14	10
5056000006	8	1/4	8	52	31	18	6	14	10

51410

TORNILLO SIMPLE - BANJO STEM SINGLE

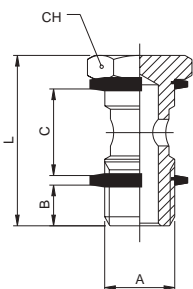

Código Code	A	B	C	L	CH	Conf. Pack.
5141000011	M5	4	12.5	22	8	25
5141000012	M6	5	12.5	23	8	25
5141000013	1/8	6	15	28	14	25
5141000014	1/4	8	17	32	17	25
5141000015	3/8	9	20	36	19	25
5141000016	1/2	10	24	42	24	25
5141000017	*M12x1.5	8	17	32	17	25

ESTE ARTÍCULO VIENE COMPLETO DE ARANDELAS EN NYLON (ART.1610). THIS ITEM WILL BE SUPPLIED WITH THE NYLON WASHERS (ART. 1610).

*CON ESTE TORNILLO UTILIZAR EL ANILLO ORIENTABLE DE 1/4. *WITH THIS BANJO STEM USING 1/4 ORIENTING BANJO BODY.

51420

TORNILLO DOBLE - BANJO STEM DOUBLE

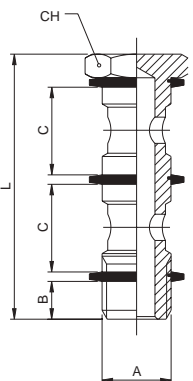

Código Code	A	B	C	L	CH	Conf. Pack.
5142000011	1/8	6	15	44.5	14	25
5142000012	1/4	8	17	50.5	17	25
5142000013	3/8	9	20	58	19	25
5142000014	1/2	10	24	68	24	25
5142000015	*M12x1.5	8	17	50.5	17	25

ESTE ARTÍCULO VIENE COMPLETO DE ARANDELAS EN NYLON (ART.1610). THIS ITEM WILL BE SUPPLIED WITH THE NYLON WASHERS (ART. 1610).

*CON ESTE TORNILLO UTILIZAR EL ANILLO ORIENTABLE DE 1/4. *WITH THIS BANJO STEM USING 1/4 ORIENTING BANJO BODY.

51430

TORNILLO TRIPLE - BANJO STEM TRIPLE

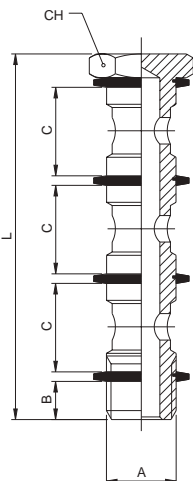

Código Code	A	B	C	L	CH	Conf. Pack.
5143000011	1/8	6	15	61	14	25
5143000012	1/4	8	17	69	17	25
5143000013	3/8	9	20	80	19	25
5143000014	1/2	10	24	94	24	10

ESTE ARTÍCULO VIENE COMPLETO DE ARANDELAS EN NYLON (ART.1610). THIS ITEM WILL BE SUPPLIED WITH THE NYLON WASHERS (ART. 1610).

51440

TORNILLO SIMPLE MACHO - HEMBRA - MALE - FEMALE BANJO STEM SINGLE

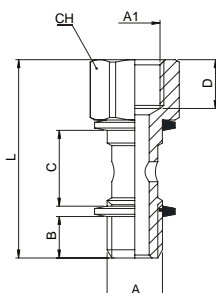

Código Code	A	A1	B	C	D	L	CH	Conf. Pack.
5144000001	1/8	1/8	6	15	8.5	34.5	14	25
5144000002	1/4	1/4	8	17	11	40.5	17	25
5144000003	3/8	3/8	9	20	12	45.5	19	25

ESTE ARTÍCULO VIENE COMPLETO DE ARANDELAS EN NYLON (ART.1610). THIS ITEM WILL BE SUPPLIED WITH THE NYLON WASHERS (ART. 1610).

50600

ADAPTADOR MACHO CILÍNDRICO CON TÓRICA - MALE ADAPTOR PARALLEL

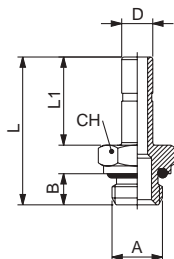

Código Code	D	A	B	L	L1	CH	Conf. Pack.
506000001	4	M5	4	24	15	8	10
506000002	4	1/8	6	26.5	15	13	10
506000012	5	M5	4	26	17	8	10
506000013	5	1/8	6	28.5	17	13	10
506000014	5	1/4	8	31	17	16	10
506000015	6	M5	4	26	17	8	10
506000003	6	1/8	6	28.5	17	13	10
506000004	6	1/4	8	31	17	16	10
506000005	8	1/8	6	29.5	18	13	10
506000006	8	1/4	8	32	18	16	10
506000007	8	3/8	9	33.5	18	20	10
506000016	10	1/8	6	33.5	22	13	10
506000008	10	1/4	8	36	22	16	10
506000009	10	3/8	9	37.5	22	20	10
506000010	12	1/4	8	38.5	24.5	16	10
506000011	12	3/8	9	40	24.5	20	10

8610

TAPÓN - PLUG

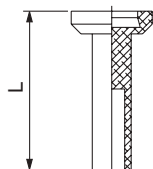

Código Code	Tubo Tube	L	Conf. Pack.
086100031X0RO	3	18	25
086100031X1RO	4	23.5	25
086100031X3RO	5	24.5	25
086100031X4RO	6	24.5	25
086100031X7RO	8	26	25
086100031X9RO	10	28.5	25
086100031Y1RO	12	28.5	25
086100031Y3RO	14	28.5	20

50625

UNIÓN DOBLE - DOUBLE JOINT

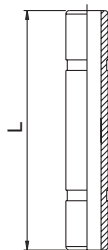

Código Code	Tubo Tube	L	Conf. Pack.
506250001X1NB	4	31	10
506250001X3NB	5	33	10
506250001X4NB	6	34	10
506250001X7NB	8	36	10
506250001X9NB	10	45	10
506250001Y1NB	12	50	10

50700

REDUCCIÓN - REDUCER

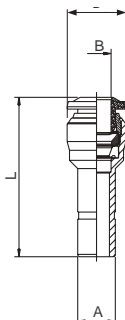

Código Code	A	B	L	D	Conf. Pack.
507000006	4	3	30	8.5	10
507000004	5	4	32	11.5	10
507000001	6	4	30	10.5	10
507000005	6	5	34.5	11.5	10
507000008	8	4	32.5	10.5	10
507000002	8	6	34.5	12.5	10
507000009	10	4	31.5	10.5	10
507000003	10	8	38.5	14.5	10
507000007	12	8	39.5	14.5	10
507000010	12	10	43	17.5	10

55800R

CARTUCHO A COMPRESIÓN - PUSH-FIT CARTRIDGES

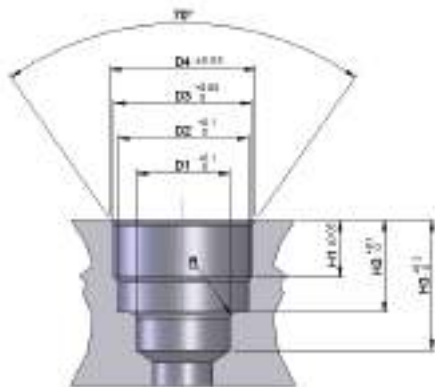
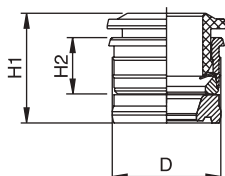

Código Code	Tubo Tube	D	H1	H2	Conf. Pack.
558000008	3	6.7	9	5	25
558000001	4	8.7	10.4	5.6	25
558000002	5	9.75	11.8	6.3	25
558000003	6	10.75	12.4	6.9	25
558000004	8	12.7	12.4	6.9	25
558000005	10	15.7	15.7	8.5	25
558000006	12	18.3	17.8	9.5	25

55800

SEDE - SEAT

DIMENSIONES SEDE CARTUCHO A COMPRESIÓN
SEATS DIMENSIONS PUSH-FIT CARTRIDGES

Tubo Tube	D1	D2	D3	D4	H1	H2	H3	R
3	3.4	6.05	6.4	6.95	3.7	6.1	8.6	0.5
4	4.2	7.45	8.4	9	3.75	6.5	9.5	0.5
5	5.2	8.35	9.4	10.15	4.45	7.9	10.5	0.5
6	6.2	9.35	10.45	11.35	5	8.5	11.5	0.5
8	8.2	11.4	12.4	12.9	5.2	8.5	12.5	0.75
10	10.2	14.5	15.4	16	6.7	10.5	15	0.75
12	12.2	17	18	19	7.5	12.1	17	1

55801

FRESA SEDE CARTUCHO A COMPRESIÓN
TOOL FOR PUSH-FIT CARTRIDGES SEAT



Código Code	Tubo Tube	Ø Cuerpo Ø Body	Conf. Pack.
558010007	3	10	1
558010001	4	10	1
558010006	5	12	1
558010002	6	12	1
558010003	8	12	1
558010004	10	16	1
558010005	12	16	1

55802

ÚTIL DE MONTAJE CARTUCHO A COMPRESIÓN
ASSEMBLING TOOL FOR PUSH-FIT CARTRIDGES



Código Code	Tubo Tube	Conf. Pack.
558020001	3	1
558020002	4	1
558020003	5	1
558020004	6	1
558020005	8	1
558020006	10	1
558020007	12	1

INSTRUCCIONES DE MONTAJE CARTUCHO A COMPRESIÓN ART.55800R PUSH-FIT CARTRIDGES ASSEMBLING INSTRUCTIONS ART. 55800R

Realizar la sede para el cartucho utilizando la correspondiente fresa Art. 55801.

Make the seat for the cartridge utilizing the suitable tool Art. 55801.



2



Insertar la junta de labio en la correspondiente sede.
Insert the lip seal inside of the seat.

Insertar el cartucho en el útil de montaje Art. 55802

Insert the cartridge into the assembling tool Art. 55802



3

4



Empujar el cartucho al interior de la sede hasta llegar al plano con el útil de montaje.

Press the cartridge inside of the seat until it will be reached the abutment surface with the assembling tool.

50900

REGLETA EN ALUMINIO A 5 VÍAS - ALUMINIUM MANIFOLD 5 WAYS

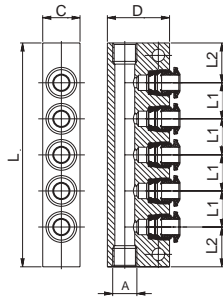

Código Code	Tubo Tube	A	C	D	L	L1	L2	Conf. Pack.
5090000001	4	1/8	15	25	75	12	13.5	5
5090000002	6	1/8	15	25	90	14.5	16	5
5090000003	6	1/4	20	30	90	14.5	16	5
5090000004	8	1/4	20	30	100	16	18	5

50990

LLAVE DE DESMONTAJE - TOOL FOR DISASSEMBLING

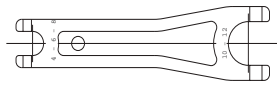

Código Code	Conf. Pack.
5099000001	10

50006

JUNTA DE CIERRE PARA ROSCAS CÓNICAS - THREAD PACKING FOR TAPER THREADS



Código Code	Rosca Thread	Conf. Pack.
5000600240200	1/8	10
5000600240300	1/4	10
5000600240400	3/8	10
5000600240500	1/2	10

55000
56000



Serie 55000

RACORDAJE AUTOMÁTICO EN TECNOPOLÍMERO
TECHNOPOLYMERIC PUSH-IN FITTINGS

Características técnicas / Technical Characteristics

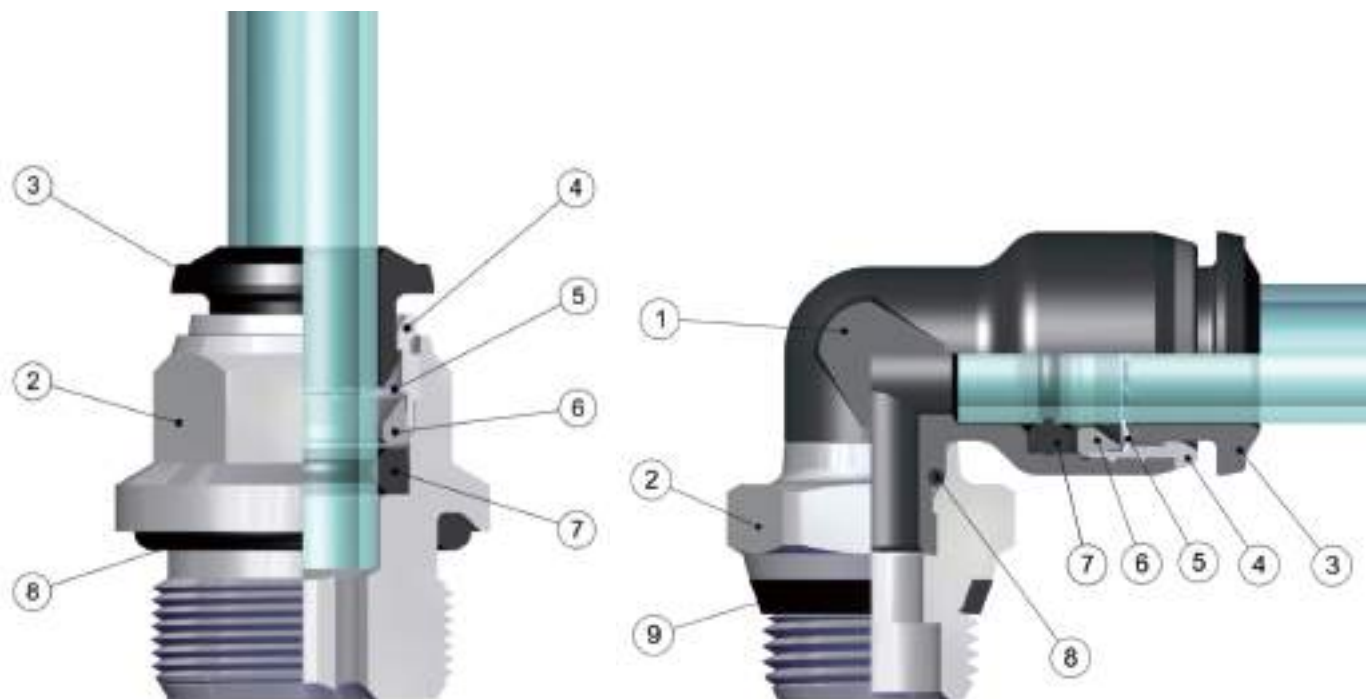

Materiales y componentes / Component Parts and Materials

- 1 Cuerpo en tecnopolímero
- 2 Cuerpo en latón niquelado
- 3 Anillo de extracción tubo en resina acetálica ISOFORM
- 4 Cápsula en latón niquelado
- 5 Pinza de agarre en acero inox aisi 304
- 6 Anillo de seguridad en tecnopolímero
- 7 Junta de labio en NBR 70
- 8 Junta tórica O-Ring en NBR 70
- 9 Junta rosca en NBR 90

- 1 Technopolymeric Body
- 2 Nickel-plated brass Body
- 3 Acetalic resin Collet ISOFORM
- 4 Nickel-plated brass Capsule
- 5 Steel aisi 304 Clamping washer
- 6 Technopolymeric Safety ring
- 7 NBR 70 Lip seal
- 8 NBR 70 O-ring
- 9 NBR 90 Thread packing

Presiones / Pressures

Presión mínima / Minimum pressure: **-0.99 bar** (-0.099 MPa)
 Presión máxima / Maximum pressure: **15 bar** (1.5 MPa)

Temperaturas / Temperatures

Temperatura mínima / Minimum temperature: **-20 °C**
 Temperatura máxima / Maximum temperature: **+80 °C**

Roscas / Threads

Rosca cónica "short" / "Short" taper thread.
 Gas cilíndrica conforme ISO 228 Clase A / Parallel gas in conformity with ISO 228 Class A.
 Métrica conforme ISO R/262 / Metric in conformity with ISO R/262.

Tubos de conexión / Connection Tubes

Tubos en material plástico:
 PA6, PA11, PA12, Polietileno, *Poliuretano; etc.
 *Para tubos en poliuretano es aconsejada una dureza de 98 shore.
 Plastic tubes:
 PA6, PA11, PA12, Polyethylene, *Polyurethane, ecc.
 *For Polyurethane hoses it is required a minimum hardness of 98 shore.

Fluidos compatibles / Fluids

Aire comprimido / Compressed air.
 Vacío / Vacuum

Rosca / Threads

La rosca cónica "short" ha sido proyectada para satisfacer las siguientes características:

- reducir la longitud
- reducir la llave respecto a algunos racores con rosca cilíndrica
- consentir el acoplamiento con diferentes standard de roscas hembra sean cónicas o cilíndricas

The "short" taper thread has been designed to offer the following advantages to the users:

- reduced overall length;
- smaller hex dimensions compared to the parallel threads;
- to allow the assembly with different female threads both taper as well as parallel;



NPT
NPTF

Cónica
Tapered

ISO 7
BSPP

Cilíndrica
Parallel

ISO 7
BSPT
PT

Cónica
Tapered

ISO 228
BSP
PF

Cilíndrica
Parallel

Consentir una completa estanqueidad incluso en superficies no perfectamente planas, cóncavas, convexas o inclinadas, con diferentes ángulos o radios.
To ensure the right tightening also with surfaces not perfectly flat, without spot-facing, concave convex and with different kinds of chamfers or radius.



Inclinada
Inclined



Cóncava
Concave



Convexa
Convex

Par de apriete / Torque specifications



PAR DE APRIETE PARA ROSCAS MACHO ISO 228 CON TÓRICA
TORQUE TO MALE THREADS ISO-228 WITH OR

MEDIDA MEASURE	PAR ACONSEJADO Nm RECOMMENDED TORQUE Nm	PAR DE ROTURA Nm BREAKING TORQUE Nm
M5	0,08	0,32
1/8	3	8
1/4	9	30
3/8	10	60
1/2	12	50

LOS VALORES DE ROTURA PUEDEN VARIAR EN FUNCIÓN DEL ARTÍCULO
BREAKING VALUES MAY VARY ACCORDING TO THE ITEM



PAR DE APRIETE PARA ROSCAS MACHO "SHORT"
TORQUE TO MALE THREADS "SHORT"

MEDIDA MEASURE	PAR MÍNIMO ACONSEJADO Nm RECOMMENDED MINIMUM TORQUE Nm	PAR MÁXIMO ACONSEJADO Nm RECOMMENDED MAX TORQUE Nm
1/8	5	7
1/4	5	7
3/8	5	7
1/2	5	7

LOS VALORES DE ROTURA PUEDEN VARIAR EN FUNCIÓN DEL ARTÍCULO
BREAKING VALUES MAY VARY ACCORDING TO THE ITEM

Todas las roscas de esta serie (incluyendo la medida de M5) están fabricadas con junta de cierre que permite la inmediata utilización del racor reduciendo notablemente el tiempo de instalación.
 All of threads from this range (also the M5), have been equipped with tightening parts which allow the direct assembly of the fittings, reducing the installation time.

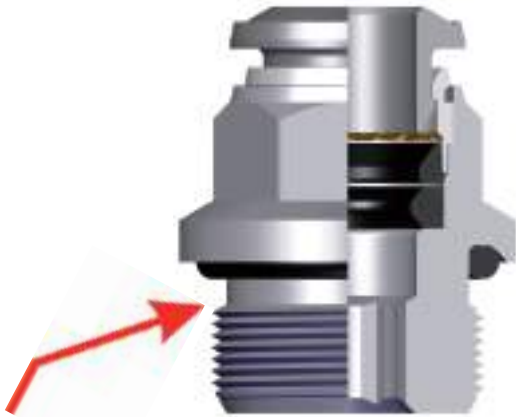

Junta tórica (O-Ring)
 para roscas cilíndricas
O-Ring for the parallel threads.

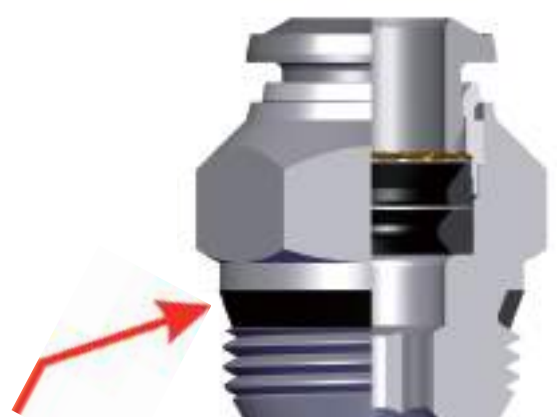

Junta de cierre para roscas cónicas "short"
 Thread packing for the taper threads.



Todos los racores rectos, con roscas cónicas o cilíndricas, pueden montarse también con llave hexagonal y es posible utilizarlos incluso en espacios muy reducidos.
All the straight fittings, with taper and parallel threads can be assembled also with Allen wrench and it is possible to use them in reduced spaces.



Pinza de sujeción / Clamping washer

La pinza en acero inox garantiza el perfecto agarre del tubo de cualquier material sin perjudicar la superficie.

The collet made in stainless steel ensure the perfect tube clamping with every kinds of materials without damage the surface.

La conexión entre tubo y racor asegura una estanqueidad total aun en condiciones de impacto o vibración.

The connection between the tube and the fitting ensure a total tightness even in severe conditions such as impact and vibrations.

La particular geometría de la junta garantiza una perfecta estanqueidad incluso en vacío.

The particular geometric shape of the seal ensure the perfect tightness even with vacuum.

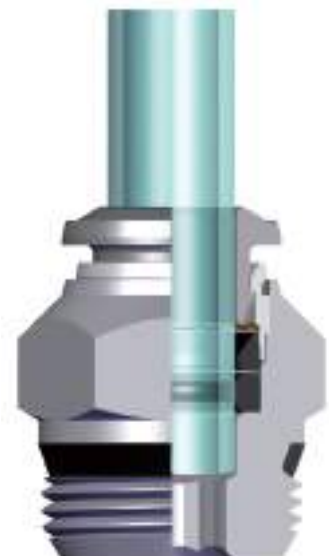

55000

RACOR RECTO MACHO CÓNICO (SHORT) - STRAIGHT MALE ADAPTOR (SHORT)

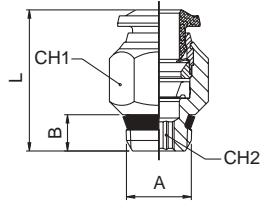

Código Code	Tubo Tube	A	B	L	CH1	CH2	Conf. Pack.
550000001	4	1/8	5.5	18	11	3	10
550000013	4	1/4	7	19	14	3	10
550000002	5	1/8	5.5	20	11	4	10
550000003	5	1/4	7	20	14	4	10
550000004	6	1/8	5.5	21.5	13	4	10
550000005	6	1/4	7	21	14	4	10
550000014	6	3/8	7.5	23	17	4	10
550000015	6	1/2	9	23.5	21	4	10
550000006	8	1/8	5.5	24.5	14	5	10
550000007	8	1/4	7	22	14	6	10
550000008	8	3/8	7.5	23	17	6	10
550000016	8	1/2	9	23.5	21	6	10
550000009	10	1/4	7	28	17	7	10
550000010	10	3/8	7.5	25.5	17	8	10
550000017	10	1/2	9	26	21	8	10
550000011	12	1/4	7	31.5	20	7	10
550000012	12	3/8	7.5	29.5	20	9	10
550000018	12	1/2	9	31.5	21	10	10
550000019	14	3/8	7.5	32.5	21	9	10
550000020	14	1/2	9	31.5	21	10	10

55010

RACOR RECTO MACHO CÓNICO (SHORT) HEXÁGONO INTERIOR - STRAIGHT MALE ADAPTOR (SHORT) WITH EXAGON EMBEDDED

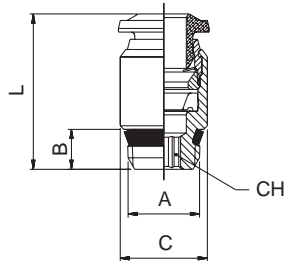

Código Code	Tubo Tube	A	B	C	L	CH	Conf. Pack.
550100001	4	1/8	5.5	11	18	3	10
550100002	6	1/8	5.5	12	21.5	4	10
550100003	6	1/4	7	14	21	4	10
550100004	8	1/8	5.5	14	25	5	10
550100005	8	1/4	7	14	22.5	6	10

50010N

RACOR RECTO MACHO CILÍNDRICO CON TÓRICA HEXÁGONO INTERIOR - STRAIGHT MALE ADAPTOR (PARALLEL) WITH EXAGON EMBEDDED

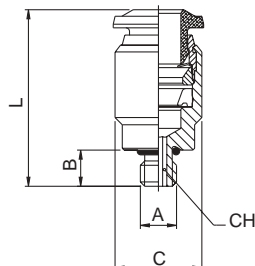

Código Code	Tubo Tube	A	B	C	L	CH	Conf. Pack.
5001000N08	3	M5	4	8	19	2.5	10
5001000N01	4	M5	4	10	21	2.5	10
5001000N09	4	M7x1	5	10	21	2.5	10
5001000N07	6	M5	4	12	24.5	2.5	10

50020N

RACOR RECTO MACHO CILÍNDRICO CON TÓRICA - STRAIGHT MALE ADAPTOR (PARALLEL)

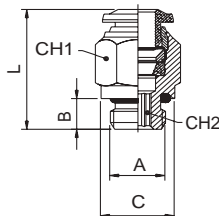

Código Code	Tubo Tube	A	B	C	L	CH1	CH2	Conf. Pack.
5002000N01	4	M5	4	8	21	10	2	10
5002000N02	4	1/8	6	13	20	10	3	10
5002000N22	4	1/4	8	16	19.5	16	3	10
5002000N18	5	M5	4	8	23.5	12	2	10
5002000N19	5	1/8	6	13	22	12	4	10
5002000N20	6	M5	4	10	24.5	13	2	10
5002000N03	6	1/8	6	13	23.5	13	4	10
5002000N04	6	1/4	8	16	23.5	13	4	10
5002000N27	6	3/8	9	20	25	13	4	10
5002000N28	6	1/2	10	25	27	13	4	10
5002000N05	8	1/8	6	13	25	14	5	10
5002000N06	8	1/4	8	16	23	14	6	10
5002000N07	8	3/8	9	20	24	14	6	10
5002000N29	8	1/2	10	25	26.5	14	6	10
5002000N08	10	1/4	8	16	30.5	17	6	10
5002000N09	10	3/8	9	20	27.5	17	8	10
5002000N31	10	1/2	10	25	27	17	8	10
5002000N32	12	1/4	8	16	34.5	20	6	10
5002000N11	12	3/8	9	20	34	20	8	10
5002000N23	12	1/2	10	25	31	22	10	10
5002000N24	14	3/8	9	20	35	21	10	10
5002000N25	14	1/2	10	25	32	22	10	10
5002000N12	6	M12x1	8	15	23.5	13	4	10
5002000N13	6	M12x1.25	8	15	23.5	13	4	10
5002000N14	6	M12x1.5	8	15	23.5	13	4	10
5002000N17	8	M12x1.5	8	15	27.5	14	6	10

50030N

RACOR RECTO HEMBRA - STRAIGHT FEMALE ADAPTOR

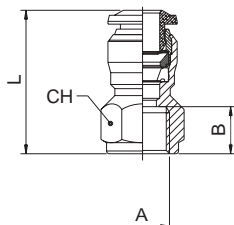

Código Code	Tubo Tube	A	B	L	CH	Conf. Pack.
5003000N08	4	M5	5.5	21	11	10
5003000N01	4	1/8	8.5	24	13	10
5003000N09	4	1/4	11	27.5	16	10
5003000N06	5	1/8	8.5	26.5	13	10
5003000N02	6	1/8	8.5	26	13	10
5003000N03	6	1/4	11	29.5	16	10
5003000N04	8	1/8	8.5	27	15	10
5003000N05	8	1/4	11	29.5	17	10
5003000N10	8	3/8	12	32	19	10
5003000N11	10	1/4	11	32	18	10
5003000N12	10	3/8	12	33.5	19	10
5003000N13	10	1/2	15	39	24	10
5003000N14	12	3/8	12	36	21	10
5003000N15	12	1/2	15	41	24	10

55040

RACOR RECTO INTERMEDIO - STRAIGHT CONNECTOR

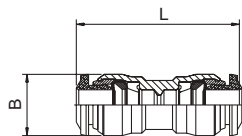

Código Code	Tubo Tube	Tubo Tube	L	B	Conf. Pack.
5504000002	4		31	10	10
5504000003	5		34	12	10
5504000004	6		35	12.5	10
5504000009	6	4	34	12.5	10
5504000005	8		37	14	10
5504000010	8	6	37.5	14	10
5504000006	10		45	17	10
5504000014	10	6	44	17	10
5504000011	10	8	44	17	10
5504000007	12		49	20	10
5504000012	12	10	49	20	10
5504000008	14		48	21	10

50050N

RACOR RECTO INTERMEDIO PASATABIQUES - BULKHEAD CONNECTOR

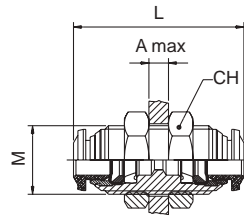

Código Code	Tubo Tube	M	L	CH	A max	Conf. Pack.
5005000N01	4	M12x1	31.5	17	7	10
5005000N06	5	M14x1	33	17	7	10
5005000N02	6	M14x1	35	17	9.5	10
5005000N03	8	M16x1	37	19	10.5	10
5005000N04	10	M20x1	43	24	12.5	10
5005000N05	12	M22x1	48	26	16.5	10

55111

RACOR A L ORIENTABLE MACHO CÓNICO (SHORT) - ORIENTING ELBOW MALE ADAPTOR (SHORT)

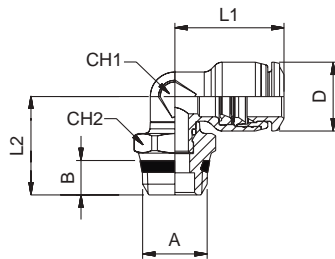

Código Code	Tubo Tube	A	B	L1	L2	CH1	CH2	D	Conf. Pack.
5511100001	4	1/8	5.5	16.5	16.5	7	13	10	10
5511100002	4	1/4	7	16.5	18	7	15	10	10
5511100003	5	1/8	5.5	20	17.4	9	13	12	10
5511100004	6	1/8	5.5	20.5	17.4	9	13	12	10
5511100005	6	1/4	7	20.5	18.9	9	15	12	10
5511100006	6	3/8	7.5	20.5	20	9	17	12	10
5511100007	6	1/2	9	20.5	22	9	21	12	10
5511100008	8	1/8	5.5	22	18.5	10	13	14	10
5511100009	8	1/4	7	22	20	10	15	14	10
5511100010	8	3/8	7.5	22	20.5	10	17	14	10
5511100011	8	1/2	9	22	23	10	21	14	10
5511100012	10	1/4	7	26.5	21.8	13	16	17	10
5511100013	10	3/8	7.5	26.5	21.8	13	17	17	10
5511100014	10	1/2	9	26.5	24.3	13	21	17	10
5511100015	12	1/4	7	30	23.1	16	16	20	10
5511100016	12	3/8	7.5	30	23.1	16	17	20	10
5511100017	12	1/2	9	30	25.6	16	21	20	10
5511100018	14	3/8	7.5	31	26.5	18	20	21	10
5511100019	14	1/2	9	31	27	18	21	21	10

55116

RACOR A L ORIENTABLE MACHO CILÍNDRICO CON TÓRICA - ORIENTING ELBOW MALE ADAPTOR (PARALLEL)

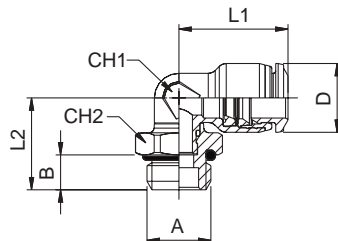

Código Code	Tubo Tube	A	B	L1	L2	CH1	CH2	D	Conf. Pack.
5511600001	4	M3x0.5	3	16.5	12	7	9	10	10
5511600002	4	M5	3.6	16.5	13.8	7	9	10	10
5511600003	4	M7x1	4.8	16.5	14.4	7	9	10	10
5511600004	4	1/8	5.4	16.5	15	7	13	10	10
5511600005	4	1/4	7.1	16.5	16.6	9	16	10	10
5511600007	5	M5	3.6	20	14.7	9	9	12	10
5511600009	5	1/8	5.4	20	15.8	9	13	12	10
5511600011	6	M5	3.6	20.5	14.7	9	9	12	10
5511600013	6	1/8	5.4	20.5	15.8	9	13	12	10
5511600014	6	1/4	7.1	20.5	17.5	9	16	12	10
5511600015	6	3/8	8.1	20.5	19	9	20	12	10
5511600016	6	1/2	9.6	20.5	21	9	25	12	10
5511600017	8	1/8	5.4	22	19.4	10	13	14	10
5511600018	8	1/4	7.1	22	18.7	10	16	14	10
5511600019	8	3/8	8.1	22	20.1	10	20	14	10
5511600020	8	1/2	9.6	22	22.1	10	25	14	10
5511600021	10	1/4	7.1	26.5	22.8	13	16	17	10
5511600022	10	3/8	8.1	26.5	22.3	13	20	17	10
5511600023	10	1/2	9.6	26.5	23.8	13	25	17	10
5511600024	12	1/4	7.1	30	24.1	16	16	20	10
5511600025	12	3/8	8.1	30	23.6	16	20	20	10
5511600026	12	1/2	9.6	30	25.1	16	25	20	10
5511600027	14	3/8	8.1	31	28.1	18	20	21	10
5511600028	14	1/2	9.6	31	26.1	18	25	21	10

55130

RACOR A L INTERMEDIO - ELBOW CONNECTOR

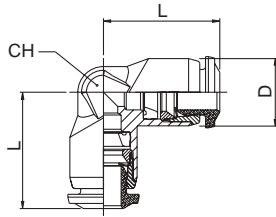

Código Code	Tubo Tube	L	CH	D	Conf. Pack.
551300002	4	16.5	9	10	10
551300003	5	20	11	12	10
551300004	6	20.5	11	12	10
551300005	8	22	13	14	10
551300006	10	26.5	16	17	10
551300007	12	30	19	20	10
551300008	14	30.5	20	21	10

55140

RACOR A L ORIENTABLE CON ESPIGA LISA CORTA - ORIENTING ELBOW

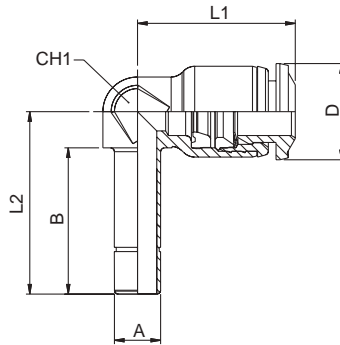

Código Code	Tubo Tube	A	B	L1	L2	CH1	D	Conf. Pack.
551400001	4	4	17	16.5	20.8	7	10	10
551400002	4	6	19	16.5	22.8	7	10	10
551400005	6	6	19	20.5	23.7	9	12.5	10
551400006	6	4	17	20.5	21.7	9	12.5	10
551400007	8	8	20	22	26	10	14	10
551400008	8	10	21.8	22	27.6	10	14	10
551400009	10	10	22.5	26.5	30	13	17	10
551400010	10	12	24.7	26.5	32.2	13	17	10
551400011	12	12	25.5	30	33.5	16	20	10

55150

RACOR A L ORIENTABLE CON ESPIGA LISA LARGA - ORIENTING ELBOW

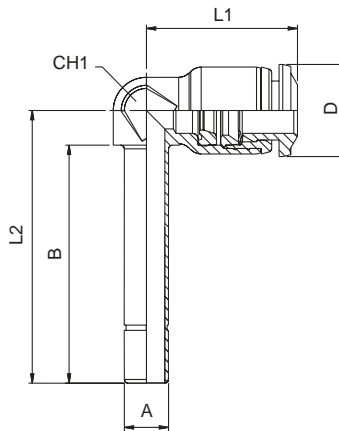

Código Code	Tubo Tube	A	B	L1	L2	CH1	D	Conf. Pack.
551500001	4	4	28	16.5	31.8	7	10	10
551500002	4	6	30.5	16.5	34.3	7	10	10
551500005	6	6	32.3	20.5	37	9	12.5	10
551500006	6	4	30	20.5	34.7	9	12.5	10
551500007	8	8	36	22	42	10	14	10
551500008	8	10	37.5	22	43.1	10	14	10
551500009	10	10	40.8	26.5	48.3	13	17	10
551500010	10	12	43.2	26.5	50.7	13	17	10
551500011	12	12	47	31	55	16	20	10

55211

RACOR A T ORIENTABLE MACHO CENTRAL CÓNICO (SHORT) - ORIENTING TEE MALE ADAPTOR (SHORT) - CENTRE LEG

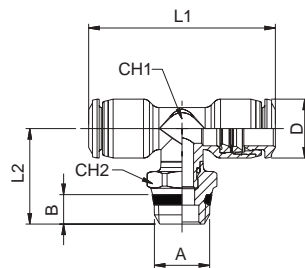

Código Code	Tubo Tube	A	B	L1	L2	CH1	CH2	D	Conf. Pack.
552110001	4	1/8	5.5	33	18.7	7	13	10	10
552110002	4	1/4	7	33	20.2	7	15	10	10
552110003	5	1/8	5.5	40	20	9	13	12	10
552110004	6	1/8	5.5	41	20	9	13	12.5	10
552110005	6	1/4	7	41	21.5	9	15	12.5	10
552110008	8	1/8	5.5	44	21.2	10	13	14	10
552110009	8	1/4	7	44	22.7	10	15	14	10
552110010	8	3/8	7.5	44	23.2	10	17	14	10
552110012	10	1/4	7	53	25.7	13	16	17	10
552110013	10	3/8	7.5	53	25.7	13	17	17	10
552110014	10	1/2	9	53	28.2	13	21	17	10
552110015	12	1/4	7	60	27.1	16	16	20	10
552110016	12	3/8	7.5	60	27.1	16	17	20	10
552110017	12	1/2	9	60	29.6	16	21	20	10
552110018	14	3/8	7.5	61	30.2	18	20	21	10
552110019	14	1/2	9	61	30.7	18	21	21	10

55216

RACOR A T ORIENTABLE MACHO CENTRAL CILÍNDRICO CON TÓRICA - ORIENTING TEE MALE ADAPTOR (PARALLEL) - CENTRE LEG

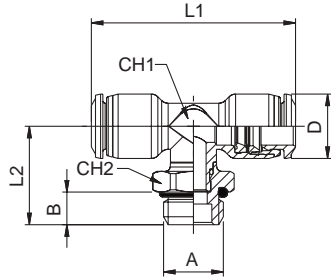

Código Code	Tubo Tube	A	B	L1	L2	CH1	CH2	D	Conf. Pack.
552160002	4	M5	3.6	33	15.5	7	9	10	10
552160004	4	1/8	5.4	33	17.1	7	13	10	10
552160005	4	1/4	7.1	33	18.8	7	16	10	10
552160007	5	M5	3.6	40	14.7	9	9	12	10
552160009	5	1/8	5.4	40	18.4	9	13	12	10
552160011	6	M5	3.6	41	14.7	9	9	12.5	10
552160013	6	1/8	5.4	41	18.4	9	13	12.5	10
552160014	6	1/4	7.1	41	20	9	16	12.5	10
552160017	8	1/8	5.4	44	22.1	10	13	14	10
552160018	8	1/4	7.1	44	21.4	10	16	14	10
552160019	8	3/8	8.1	44	22.8	10	20	14	10
552160021	10	1/4	7.1	53	26.7	13	16	17	10
552160022	10	3/8	8.1	53	26.2	13	20	17	10
552160023	10	1/2	9.6	53	27.7	13	25	17	10
552160024	12	1/4	7.1	61.5	28.1	16	16	20	10
552160025	12	3/8	8.1	61.5	27.6	16	20	20	10
552160026	12	1/2	9.6	61.5	29.1	16	25	20	10
552160027	14	3/8	8.1	61	31.8	18	20	21	10
552160028	14	1/2	9.6	61	29.8	18	25	21	10

55223

RACOR A T ORIENTABLE MACHO LATERAL CÓNICO (SHORT) - ORIENTING TEE MALE ADAPTOR (SHORT) - OFF - SET LEG

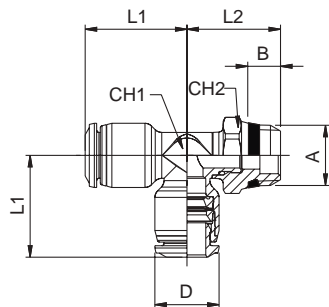

Código Code	Tubo Tube	A	B	L1	L2	CH1	CH2	D	Conf. Pack.
552230001	4	1/8	5.5	16.5	18.2	7	13	10	10
552230002	4	1/4	7	16.5	19.7	7	15	10	10
552230003	5	1/8	5.5	20	17.4	9	13	12	10
552230004	6	1/8	5.5	20.5	17.4	9	13	12.5	10
552230005	6	1/4	7	20.5	18.9	9	15	12.5	10
552230008	8	1/8	5.5	22	18.9	10	13	14	10
552230009	8	1/4	7	22	20.4	10	15	14	10
552230010	8	3/8	7.5	22	20.9	10	17	14	10
552230012	10	1/4	7	26.5	21.8	13	16	17	10
552230013	10	3/8	7.5	26.5	21.8	13	17	17	10
552230014	10	1/2	9	26.5	24.3	13	21	17	10
552230015	12	1/4	7	31	23.1	16	16	20	10
552230016	12	3/8	7.5	31	23.1	16	17	20	10
552230017	12	1/2	9	31	25.6	16	21	20	10
552230018	14	3/8	7.5	30.5	26.5	18	20	21	10
552230019	14	1/2	9	30.5	27	18	21	21	10

55226

RACOR A T ORIENTABLE MACHO LATERAL CILÍNDRICO CON TÓRICA - ORIENTING TEE MALE ADAPTOR (PARALLEL) - OFF - SET LEG

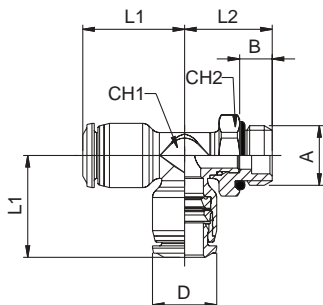

Código Code	Tubo Tube	A	B	L1	L2	CH1	CH2	D	Conf. Pack.
552260002	4	M5	3.6	16.5	15.5	7	9	10	10
552260004	4	1/8	5.4	16.5	16.6	7	13	10	10
552260005	4	1/4	7.1	16.5	18.3	7	16	10	10
552260007	5	M5	3.6	20	14.7	9	9	12	10
552260009	5	1/8	5.4	20	15.8	9	13	12	10
552260011	6	M5	3.6	20.5	14.7	9	9	12.5	10
552260013	6	1/8	5.4	20.5	15.8	9	13	12.5	10
552260014	6	1/4	7.1	20.5	17.5	9	16	12.5	10
552260017	8	1/8	5.4	22	19.8	10	13	14	10
552260018	8	1/4	7.1	22	19.1	10	16	14	10
552260019	8	3/8	8.1	22	20.5	10	20	14	10
552260021	10	1/4	7.1	26.5	22.8	13	16	17	10
552260022	10	3/8	8.1	26.5	22.3	13	20	17	10
552260023	10	1/2	9.6	26.5	23.8	13	25	17	10
552260024	12	1/4	7.1	31	24.1	16	16	20	10
552260025	12	3/8	8.1	31	23.6	16	20	20	10
552260026	12	1/2	9.6	31	25.1	16	25	20	10
552260027	14	3/8	8.1	30.5	28.1	18	20	21	10
552260028	14	1/2	9.6	30.5	26.1	18	25	21	10

55230

RACOR A T INTERMEDIO - TEE CONNECTOR

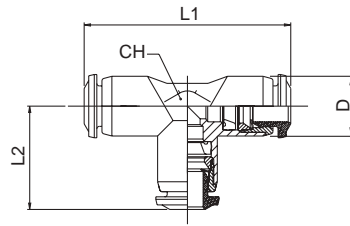

Código Code	Tubo Tube	L1	L2	CH	D	Conf. Pack.
5523000002	4	33	16.5	9	10	10
5523000003	5	40	20	11	12	10
5523000004	6	41	20.5	11	12	10
5523000005	8	44	22	13	14	10
5523000006	10	53	26.5	16	17	10
5523000007	12	61.5	30	19	20	10
5523000008	14	61	30.5	20	21	10

55240

RACOR A T ORIENTABLE CON ESPIGA LISA CORTA - ORIENTING TEE

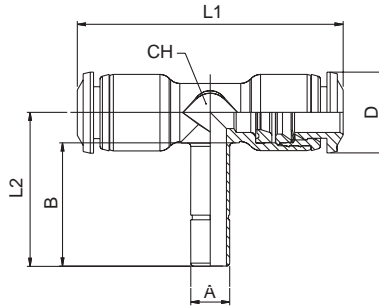

Código Code	Tubo Tube	A	B	L1	L2	CH	D	Conf. Pack.
5524000001	4	4	17	33	20.7	7	10	10
5524000002	4	6	19	33	22.7	7	10	10
5524000005	6	6	19	41	23.7	9	12.5	10
5524000006	6	4	17	41	21.7	9	12.5	10
5524000007	8	8	20	44	26	10	14	10
5524000008	8	10	22.2	44	28	10	14	10
5524000009	10	10	22.5	53	30	13	17	10
5524000010	10	12	25	53	32.2	13	17	10
5524000011	12	12	25.5	61.5	33.5	16	20	10

55310

RACOR A Y INTERMEDIO - Y CONNECTOR

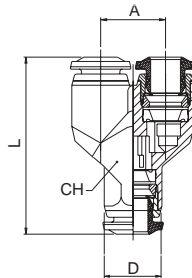

Código Code	Tubo Tube	A	L	CH	D	Conf. Pack.
5531000002	4	11	31.5	10	10	10
5531000004	6	13.5	37	12	12	10
5531000005	8	15.5	40	14	14	10
5531000006	10	19	48.5	17	18	10
5531000007	12	22	57.5	20	20	10

55320

RACOR A Y ORIENTABLE MACHO CÓNICO (SHORT) - ORIENTING Y MALE ADAPTOR (SHORT)

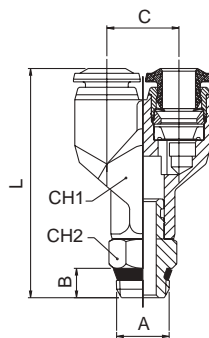

Código Code	Tubo Tube	A	B	C	L	CH1	CH2	Conf. Pack.
5532000002	4	1/8	5.5	11	38	10	11	10
5532000007	4	1/4	7	11	40.5	10	14	10
5532000003	6	1/8	5.5	13.5	43	12	11	10
5532000004	6	1/4	7	13.5	45.5	12	14	10
5532000005	8	1/8	5.5	15.5	46.5	14	11	10
5532000006	8	1/4	7	15.5	49	14	14	10
5532000008	8	3/8	7.5	15.5	49.5	14	17	10
5532000009	10	1/4	7	19	56.5	17	14	10
5532000010	10	3/8	7.5	19	57.5	17	17	10
5532000011	10	1/2	9	19	60	17	21	10
5532000012	12	3/8	7.5	22	66.5	20	17	10
5532000013	12	1/2	9	22	68	20	21	10

55325

RACOR A Y ORIENTABLE MACHO CILÍNDRICO CON TÓRICA - ORIENTING Y MALE ADAPTOR (PARALLEL)

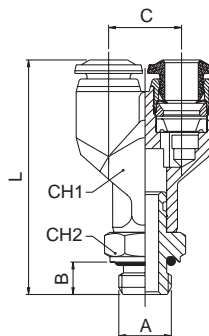

Código Code	Tubo Tube	A	B	C	L	CH1	CH2	Conf. Pack.
5532500002	4	M5	4	11	36.5	10	10	10
5532500003	4	1/8	6	11	38.5	10	13	10
5532500009	4	1/4	8	11	40.5	10	16	10
5532500004	6	M5	4	13.5	41.5	12	10	10
5532500005	6	1/8	6	13.5	43.5	12	13	10
5532500006	6	1/4	8	13.5	46.5	12	16	10
5532500007	8	1/8	6	15.5	47	14	13	10
5532500008	8	1/4	8	15.5	50	14	16	10
5532500010	8	3/8	9	15.5	52	14	20	10
5532500011	10	1/4	8	19	59.5	17	16	10
5532500012	10	3/8	9	19	59.5	17	20	10
5532500013	10	1/2	10	19	62	17	24	10
5532500014	12	3/8	9	22	68.5	20	20	10
5532500015	12	1/2	10	22	71	20	24	10

55330

RACOR A Y MÚLTIPLE INTERMEDIO - Y CONNECTOR MANIFOLD

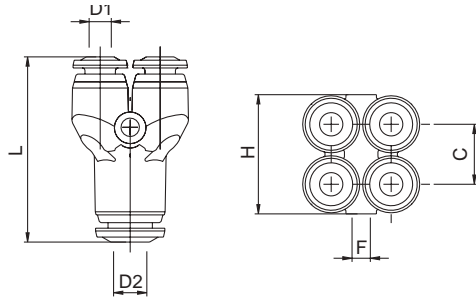

Código Code	D1	D2	C	L	F	H	Conf. Pack.
553300001	4	4	10.8	33.5	3.3	21.5	10
553300002	4	6	10.8	34.5	3.3	21.5	10
553300003	6	6	13.3	39.5	3.3	26.8	10
553300004	6	8	13.3	40	3.3	26.8	10

55340

RACOR A Y MÚLTIPLE ORIENTABLE MACHO CÓNICO (SHORT) - Y CONNECTOR ORIENTING MALE ADAPTOR (SHORT)

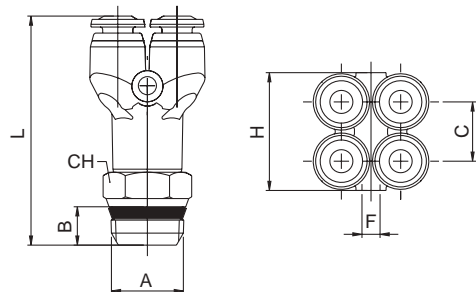

Código Code	Tubo Tube	A	B	C	L	H	CH	F	Conf. Pack.
553400001	4 1/8	5.5	10.8	39.5	21.5	11	3.3	10	
553400002	4 1/4	7	10.8	42	21.5	14	3.3	10	
553400003	6 1/8	5.5	13.3	46.5	26.8	11	3.3	10	
553400004	6 1/4	7	13.3	48	26.8	14	3.3	10	

55345

RACOR A Y MÚLTIPLE ORIENTABLE MACHO CILÍNDRICO CON TÓRICA - Y CONNECTOR ORIENTING MALE ADAPTOR (PARALLEL)

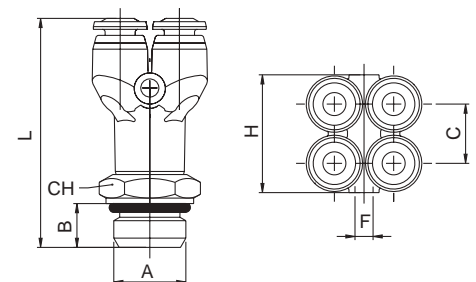

Código Code	Tubo Tube	A	B	C	L	H	CH	F	Conf. Pack.
553450001	4 1/8	6	10.8	40	21.5	13	3.3	10	
553450002	4 1/4	8	10.8	42	21.5	16	3.3	10	
553450003	6 1/8	6	13.3	47	26.8	13	3.3	10	
553450004	6 1/4	8	13.3	49	26.8	16	3.3	10	

55350

RACOR DISTRIBUIDOR MÚLTIPLE DE REDUCCIÓN - REDUCTION MANIFOLD

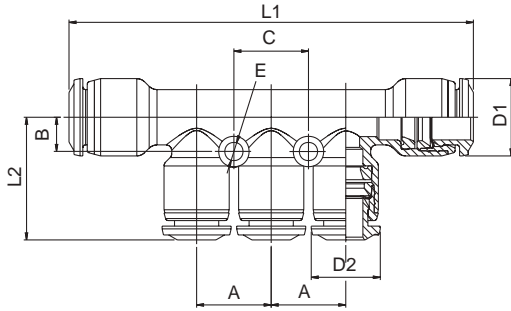

Código Code	Tubo Tube	A	B	L1	L2	C	D1	D2	E	Conf. Pack.
553500001	6-4	13.5	6	74	21.8	13.5	14	12	3.3	10
553500002	8-4	13.5	6	73	21.8	13.5	14	12	3.3	10
553500003	8-6	13.5	6	73	22.3	13.5	14	12.5	3.3	10
553500004	10-6	15	7	83	23.7	15	17	14	3.3	10
553500005	10-8	15	7	83	23.2	15	17	14	3.3	10

55360

RACOR DISTRIBUIDOR MÚLTIPLE DE REDUCCIÓN ORIENTABLE MACHO CÓNICO (SHORT) - REDUCTION MANIFOLD ORIENTING MALE ADAPTOR (SHORT)

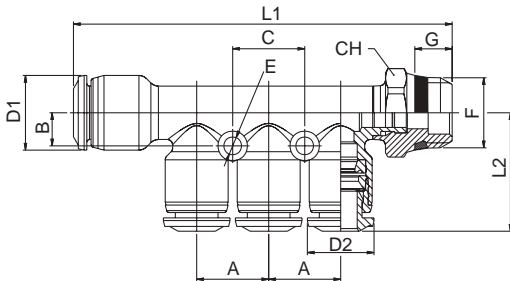

Código Code	Tubo Tube	F	A	B	L1	L2	C	D1	D2	E	G	CH	Conf. Pack.
553600001	6-4	1/8	13.5	6	70	21.8	13.5	14	12	3.3	5.5	13	10
553600002	6-4	1/4	13.5	6	71.4	21.8	13.5	14	12	3.3	7	15	10
553600003	8-4	1/8	13.5	6	70	21.8	13.5	14	12	3.3	5.5	13	10
553600004	8-4	1/4	13.5	6	71.4	21.8	13.5	14	12	3.3	7	15	10
553600005	8-6	1/8	13.5	6	70	22.3	13.5	14	12.5	3.3	5.5	13	10
553600006	8-6	1/4	13.5	6	71.4	22.3	13.5	14	12.5	3.3	7	15	10
553600007	10-6	1/4	15	7	81.5	23.7	15	17	14	3.3	7	16	10
553600008	10-6	3/8	15	7	81.5	23.7	15	17	14	3.3	7.5	17	10
553600009	10-8	1/4	15	7	81.5	23.2	15	17	14	3.3	7	16	10
553600010	10-8	3/8	15	7	81.5	23.2	15	17	14	3.3	7.5	17	10

55365

RACOR DISTRIBUIDOR MÚLTIPLE DE REDUCCIÓN ORIENTABLE MACHO CILÍNDRICO CON TÓRICA - REDUCTION MANIFOLD ORIENTING MALE ADAPTOR (PARALLEL)

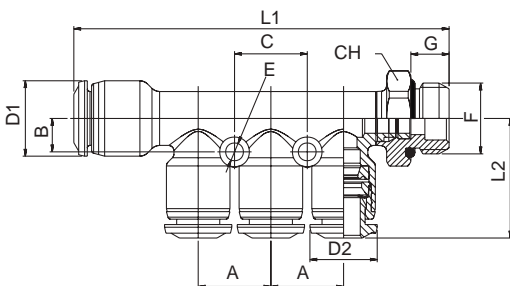

Código Code	Tubo Tube	F	A	B	L1	L2	C	D1	D2	E	G	CH	Conf. Pack.
553650001	6-4	1/8	13.5	6	70.7	21.8	13.5	14	12	3.3	5.4	13	10
553650002	6-4	1/4	13.5	6	70	21.8	13.5	14	12	3.3	7.1	16	10
553650003	8-4	1/8	13.5	6	70.7	21.8	13.5	14	12	3.3	5.4	13	10
553650004	8-4	1/4	13.5	6	70	21.8	13.5	14	12	3.3	7.1	16	10
553650005	8-6	1/8	13.5	6	70.7	22.3	13.5	14	12.5	3.3	5.4	13	10
553650006	8-6	1/4	13.5	6	70	22.3	13.5	14	12.5	3.3	7.1	16	10
553650007	10-6	1/4	15	7	82.4	23.7	15	17	14	3.3	7.1	16	10
553650008	10-6	3/8	15	7	82	23.7	15	17	14	3.3	8.1	20	10
553650009	10-8	1/4	15	7	82.4	23.2	15	17	14	3.3	7.1	16	10
553650010	10-8	3/8	15	7	82	23.2	15	17	14	3.3	8.1	20	10

Montaje tornillo con anillo orientable / Banjo Stem Assemblies

Ejemplo de montaje del tornillo con el anillo orientable simple y doble.

Assembling examples of various banjo stems with single and double banjo bodies.



TORNILLO SIMPLE
BANJO STEM SINGLE

TORNILLO DOBLE
BANJO STEM DOUBLE

TORNILLO TRIPLE
BANJO STEM TRIPLE

55500

ANILLO ORIENTABLE SIMPLE - SINGLE BANJO BODY

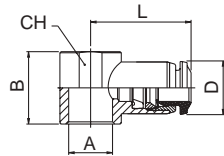

Código Code	Tubo Tube	A	B	L	CH	D	Conf. Pack.
555000001	4	M5	14	19.5	9	10	10
555000002	4	M6	14	19.5	9	10	10
555000003	4	1/8	16.5	21.5	14	10	10
555000004	5	M5	14	20.5	9	12	10
555000005	5	M6	14	20.5	9	12	10
555000006	5	1/8	16.5	22.5	14	12	10
555000007	5	1/4	18.5	25	18	12	10
555000008	6	M5	14	21	9	12	10
555000009	6	M6	14	21	9	12	10
555000010	6	1/8	16.5	23	14	12	10
555000011	6	1/4	18.5	25.5	18	12	10
555000012	8	1/8	16.5	23.5	14	14	10
555000013	8	1/4	18.5	26	18	14	10
555000014	8	3/8	22	27.5	21	14	10
555000015	10	3/8	22	30.5	21	17	10
555000016	12	3/8	22	32.5	21	20	10
555000017	12	1/2	26	35	26	20	10

55510

ANILLO ORIENTABLE DOBLE - DOUBLE BANJO BODY

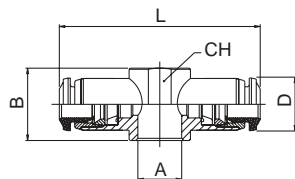

Código Code	Tubo Tube	A	B	L	CH	D	Conf. Pack.
555100001	4	M5	14	39	9	10	10
555100003	4	1/8	16.5	43	14	10	10
555100006	5	1/8	16.5	45	14	12	10
555100007	5	1/4	18.5	50	18	12	10
555100010	6	1/8	16.5	46	14	12	10
555100011	6	1/4	18.5	51	18	12	10
555100012	8	1/8	16.5	47	14	14	10
555100013	8	1/4	18.5	52	18	14	10

55410

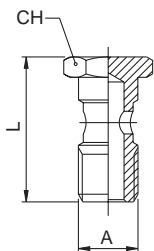
TORNILLO SIMPLE - BANJO STEM SINGLE

Código Code	A	L	CH	Conf. Pack.
554100001B5NB	M5	22	8	25
554100001B8NB	M6	23	8	25
55410000102NB	1/8	28	14	25
55410000103NB	1/4	32	17	25
55410000104NT	3/8	36	19	25
55410000105NT	1/2	42	24	25
554100001D6NT	*M12x1.5	32	17	25

*CON ESTE TORNILLO UTILIZAR EL ANILLO ORIENTABLE DE 1/4.
 *WITH THIS BANJO STEM USING 1/4 ORIENTING BANJO BODY.

55420

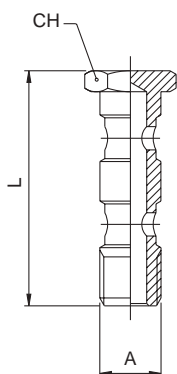
TORNILLO DOBLE - BANJO STEM DOUBLE

Código Code	A	L	CH	Conf. Pack.
55420000102NT	1/8	44.5	14	25
55420000103NT	1/4	50.5	17	25
55420000104NT	3/8	58	19	25
55420000105NT	1/2	68	24	25
554200001D6NT	*M12x1.5	50.5	17	25

*CON ESTE TORNILLO UTILIZAR EL ANILLO ORIENTABLE DE 1/4.
 *WITH THIS BANJO STEM USING 1/4 ORIENTING BANJO BODY.

55430

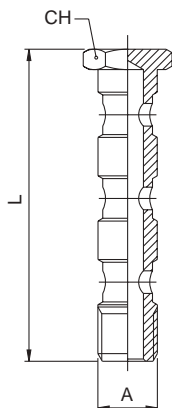
TORNILLO TRIPLE - BANJO STEM TRIPLE

Código Code	A	L	CH	Conf. Pack.
55430000102NT	1/8	61	14	25
55430000103NT	1/4	69	17	25
55430000104NT	3/8	80	19	25
55430000105NT	1/2	94	24	10

55440

TORNILLO SIMPLE MACHO - HEMBRA - MALE - FEMALE BANJO STEM SINGLE

Código Code	A	B	C	L	CH	Conf. Pack.
55440000102NB	1/8	1/8	8.5	34.5	14	25
55440000103NB	1/4	1/4	11	40.5	17	25
55440000104NB	3/8	3/8	12	45.5	19	25

50600

ADAPTADOR MACHO CILÍNDRICO CON TÓRICA - MALE ADAPTOR PARALLEL

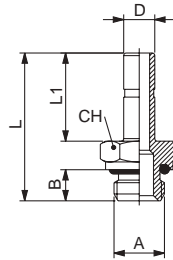

Código Code	D	A	B	L	L1	CH	Conf. Pack.
506000001	4	M5	4	24	15	8	10
506000002	4	1/8	6	26.5	15	13	10
506000012	5	M5	4	26	17	8	10
506000013	5	1/8	6	28.5	17	13	10
506000014	5	1/4	8	31	17	16	10
506000015	6	M5	4	26	17	8	10
506000003	6	1/8	6	28.5	17	13	10
506000004	6	1/4	8	31	17	16	10
506000005	8	1/8	6	29.5	18	13	10
506000006	8	1/4	8	32	18	16	10
506000007	8	3/8	9	33.5	18	20	10
506000016	10	1/8	6	33.5	22	13	10
506000008	10	1/4	8	36	22	16	10
506000009	10	3/8	9	37.5	22	20	10
506000010	12	1/4	8	38.5	24.5	16	10
506000011	12	3/8	9	40	24.5	20	10

8610

TAPÓN (RILSAN PA 11) - PLUG (PA11)

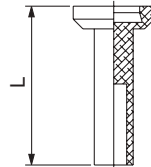

Código Code	Tubo Tube	L	Conf. Pack.
086100031X0RO	3	18	25
086100031X1RO	4	23.5	25
086100031X3RO	5	24.5	25
086100031X4RO	6	24.5	25
086100031X7RO	8	26	25
086100031X9RO	10	28.5	25
086100031Y1RO	12	28.5	25
086100031Y3RO	14	28.5	20

50625

UNIÓN DOBLE - DOUBLE JOINT

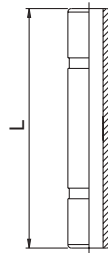

Código Code	Tubo Tube	L	Conf. Pack.
506250001X1NB	4	31	10
506250001X3NB	5	33	10
506250001X4NB	6	34	10
506250001X7NB	8	36	10
506250001X9NB	10	45	10
506250001Y1NB	12	50	10

50700N

REDUCCIÓN - REDUCER

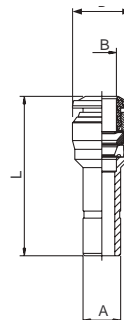

Código Code	A	B	L	D	Conf. Pack.
5070000N06	4	3	30	8.5	10
5070000N04	5	4	32	11.5	10
5070000N01	6	4	30	10.5	10
5070000N05	6	5	34.5	11.5	10
5070000N08	8	4	32.5	10.5	10
5070000N02	8	6	34.5	12.5	10
5070000N09	10	4	31.5	10.5	10
5070000N03	10	8	38.5	14.5	10
5070000N07	12	8	39.5	14.5	10
5070000N10	12	10	43	17.5	10

55800N

CARTUCHO A COMPRESIÓN - PUSH-FIT CARTRIDGES

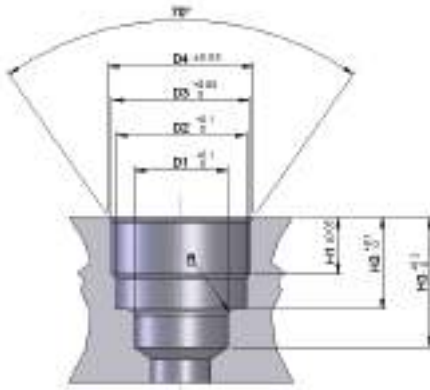
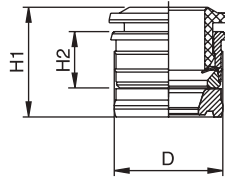

Código Code	Tubo Tube	D	H1	H2	Conf. Pack.
558000N08	3	6.7	9	5	25
558000N01	4	8.7	10.4	5.6	25
558000N02	5	9.75	11.8	6.3	25
558000N03	6	10.75	12.4	6.9	25
558000N04	8	12.7	12.4	6.9	25
558000N05	10	15.7	15.7	8.5	25
558000N06	12	18.3	17.8	9.5	25

55800

SEDE - SEAT

DIMENSIONES SEDE CARTUCHO A COMPRESIÓN
SEATS DIMENSIONS PUSH-FIT CARTRIDGES

Tubo Tube	D1	D2	D3	D4	H1	H2	H3	R
3	3.4	6.05	6.4	6.95	3.7	6.1	8.6	0.5
4	4.2	7.45	8.4	9	3.75	6.5	9.5	0.5
5	5.2	8.35	9.4	10.15	4.45	7.9	10.5	0.5
6	6.2	9.35	10.45	11.35	5	8.5	11.5	0.5
8	8.2	11.4	12.4	12.9	5.2	8.5	12.5	0.75
10	10.2	14.5	15.4	16	6.7	10.5	15	0.75
12	12.2	17	18	19	7.5	12.1	17	1

55801

FRESA SEDE CARTUCHO A COMPRESIÓN
TOOL FOR PUSH-FIT CARTRIDGES SEAT



Código Code	Tubo Tube	Ø Gambo ø Body	Conf. Pack.
5580100007	3	10	1
5580100001	4	10	1
5580100006	5	12	1
5580100002	6	12	1
5580100003	8	12	1
5580100004	10	16	1
5580100005	12	16	1

55802

ÚTIL DE MONTAJE CARTUCHO A COMPRESIÓN
ASSEMBLING TOOL FOR PUSH-FIT CARTRIDGES



Código Code	Tubo Tube	Conf. Pack.
5580200001	3	1
5580200002	4	1
5580200003	5	1
5580200004	6	1
5580200005	8	1
5580200006	10	1
5580200007	12	1

INSTRUCCIONES DE MONTAJE CARTUCHO A COMPRESIÓN ART.55800N PUSH-FIT CARTRIDGES ASSEMBLING INSTRUCTIONS ART. 55800N

Realizar la sede para el cartucho utilizando la correspondiente fresa Art. 55801.

Make the seat for the cartridge utilizing the suitable tool Art. 55801.



2



Insertar la junta de labio en la correspondiente sede.
Insert the lip seal inside of the seat.

Insertar el cartucho en el útil de montaje Art. 55802

Insert the cartridge into the assembling tool Art. 55802



3

4



Empujar el cartucho al interior de la sede hasta llegar al plano con el útil de montaje.

Press the cartridge inside of the seat until it will be reached the abutment surface with the assembling tool.

50900N

REGLETA EN ALUMINIO A 5 VÍAS - ALUMINIUM MANIFOLD 5 WAYS

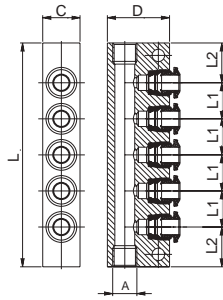

Código Code	Tubo Tube	A	C	D	L	L1	L2	Conf. Pack.
5090000N01	4	1/8	15	25	75	12	13.5	5
5090000N02	6	1/8	15	25	90	14.5	16	5
5090000N03	6	1/4	20	30	90	14.5	16	5
5090000N04	8	1/4	20	30	100	16	18	5

50990

LLAVE DE DESMONTAJE - TOOL FOR DISASSEMBLING

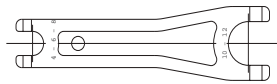

Código Code	Conf. Pack.
5099000001	10

Serie 56000 "mini"

56020

RACOR RECTO MACHO CILÍNDRICO - STRAIGHT MALE ADAPTOR (PARALLEL)

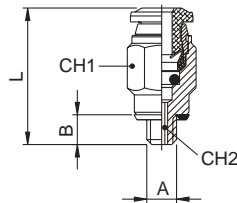

Código Code	Tubo Tube	A	B	L	CH1	CH2	Conf. Pack.
5602000001	2	M3	3	13.5	6	1.5	50
5602000002	2	M5	4	12.5	7	1.5	50
5602000003	3	M3	3	13.5	6	1.5	50
5602000004	3	M5	4	13.5	7	2	50

56115

RACOR A L ORIENTABLE MACHO CILÍNDRICO - ORIENTING ELBOW MALE ADAPTOR (PARALLEL)

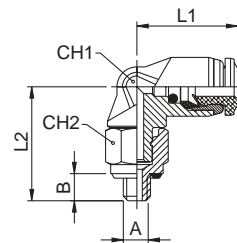

Código Code	Tubo Tube	A	B	L1	L2	CH1	CH2	Conf. Pack.
5611500001	2	M3	3	11	13.5	6	8	50
5611500002	2	M5	4	11	12.5	6	8	50
5611500003	3	M3	3	11	13.5	6	8	50
5611500004	3	M5	4	11	12.5	6	8	50

56130

RACOR A L INTERMEDIO - ELBOW CONNECTOR

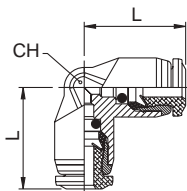

Código Code	Tubo Tube	L	CH	Conf. Pack.
5613000001	2	11	6	50
5613000002	3	11	6	50

56215

RACOR A T ORIENTABLE MACHO CENTRAL CILÍNDRICO - ORIENTING TEE MALE ADAPTOR (PARALLEL) - CENTRE LEG

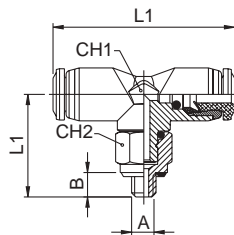

Código Code	Tubo Tube	A	B	L1	L2	CH1	CH2	Conf. Pack.
5621500001	2	M3	3	22	12.5	6	8	50
5621500002	2	M5	4	22	13.5	6	8	50
5621500003	3	M3	3	22	12.5	6	8	50
5621500004	3	M5	4	22	13.5	6	8	50

56225

RACOR A T ORIENTABLE MACHO LATERAL CILÍNDRICO - ORIENTING TEE MALE ADAPTOR (PARALLEL) - OFF-CENTRE LEG

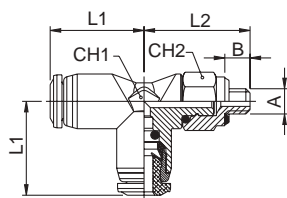

Código Code	Tubo Tube	A	B	L1	L2	CH1	CH2	Conf. Pack.
5622500001	2	M3	3	11	12.5	6	8	50
5622500002	2	M5	4	11	13.5	6	8	50
5622500003	3	M3	3	11	12.5	6	8	50
5622500004	3	M5	4	11	13.5	6	8	50

56230

RACOR A T INTERMEDIO - TEE CONNECTOR

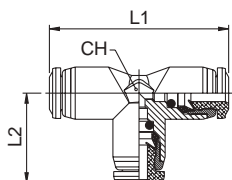

Código Code	Tubo Tube	L1	L2	CH	Conf. Pack.
5623000001	2	22	11	6	50
5623000002	3	22	11	6	50

56550

RACOR ORIENTABLE SIMPLE - ORIENTING SINGLE BANJO BODY MALE

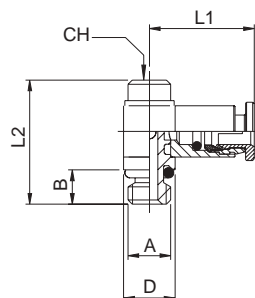

Código Code	Tubo Tube	A	B	D	L1	L2	CH	Conf. Pack.
5655000004	3	M5	4	6	12	14.5	2	50
5655000003	3	M3	3	6	12	13.5	2	50

Note:

Note:



57000

Serie 57000

RACORDAJE AUTOMÁTICO CON ANILLO METÁLICO
PUSH-IN FITTINGS WITH METAL COLLET

Características Técnicas / Technical Characteristics

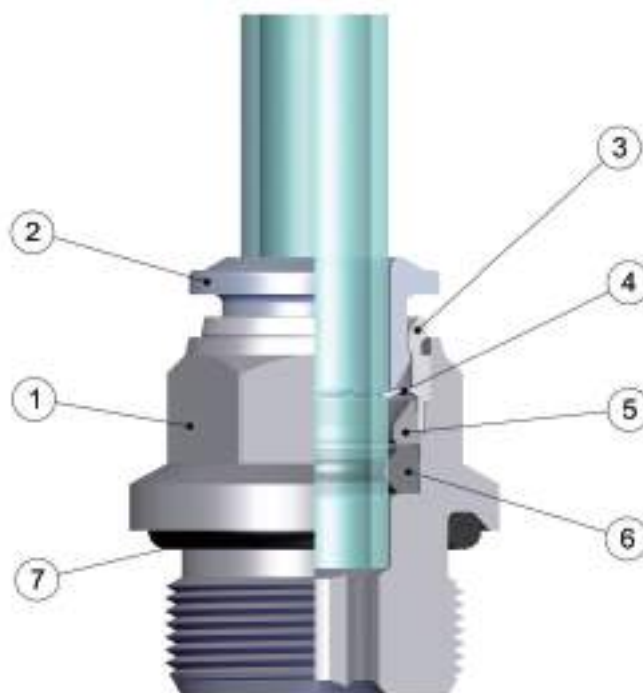

**FKM Y EPDM
BAJO PEDIDO**
*IF REQUESTED
FKM OR EPDM*

Materiales y Componentes / Component Parts and Materials

- 1 Cuerpo en latón niquelado
- 2 Anillo de extracción tubo en latón niquelado
- 3 Cápsula en latón niquelado
- 4 Pinza de agarre en acero inox aisi 304
- 5 Anillo de seguridad en tecnopolímero
- 6 Junta de labio en NBR 70 (FKM Y EPDM bajo pedido)
- 7 Junta rosca en NBR 90 (FKM Y EPDM bajo pedido)

- 1 Nickel-plated brass Body
- 2 Nickel-plated brass Collet
- 3 Nickel-plated brass Capsule
- 4 Steel aisi 304 Clamping washer
- 5 Technopolymeric Safety ring
- 6 Nbr 70 Lip seal (if requested FKM - EPDM)
- 7 Nbr 90 Thread packing (if requested FKM - EPDM)

Presiones / Pressures

Presión mínima / Minimum pressure: **-0.99 bar** (-0.099 MPa)
Presión máxima / Maximum pressure: **15 bar** (1.5 MPa)

Temperaturas / Temperatures

Temperatura mínima / Minimum temperature: -20 °C
Temperatura máxima / Maximum temperature: +80 °C
Con juntas FKM / With FKM Seals
Temperatura mínima / Minimum temperature: -15 °C
Temperatura máxima / Maximum temperature: +200 °C
Con juntas EPDM / With EPDM Seals
Temperatura mínima / Minimum temperature: -40 °C
Temperatura máxima / Maximum temperature: +160 °C

Roscas / Threads

Rosca cónica "short" / "Short" taper thread.
Gas cónica conforme ISO 7.1, BS 21, DIN 2999 / Tapered gas in conformity with ISO 7.1, BS 21, DIN 2999.
Gas cilíndrica conforme ISO 228 Clase A / Parallel gas in conformity with ISO 228 Class A.

Tubos de conexión / Connection Tubes

Tubos en material plástico:
PA6, PA11, PA12, Polietileno, *Poliuretano; etc.
*Para tubos en poliuretano es aconsejada una dureza de 98 shore.
Plastic tubes:
PA6, PA11, PA12, Polyethylene, *Polyurethane, ecc.
*For Polyurethane hoses it is required a minimum hardness of 98 shore.

Fluidos compatibles / Fluids

Aire comprimido / Compressed air.
Vacío / Vacuum
Agua / Water

Fluidos para la Industria alimentaria y química compatible con los componentes del racor.
Fluid for food and chemical industry compatible with fitting components.

Roscas / Threads

La rosca cónica "short" ha sido proyectada para satisfacer las siguientes características:

- reducir la longitud
- reducir la llave respecto a algunos racores con rosca cilíndrica
- consentir el acoplamiento con diferentes standard de roscas hembra sean cónicas o cilíndricas

The "short" taper thread has been designed to offer the following advantages to the users:

- reduced overall length;
- smaller hex dimensions compared to the parallel threads;
- to allow the assembly with different female threads both taper as well as parallel;



NPT
NPTF

Cónica
Tapered

ISO 7
BSPP

Cilíndrica
Parallel

ISO 7
BSPT
PT

Cónica
Tapered

ISO 228
BSP
PF

Cilíndrica
Parallel

consentir una completa estanqueidad incluso en superficies no perfectamente planas, cóncavas, convexas o inclinadas, con diferentes ángulos o radios.

To ensure the right tightening also with surfaces not perfectly flat, without spot-facing, concave convex and with different kinds of chamfers or radius.



Inclinada
Inclined



Cóncava
Concave



Convexa
Convex

Par de apriete / Torque specifications



PAR DE APRIETE PARA ROSCAS MACHO ISO 228 CON TÓRICA
TORQUE TO MALE THREADS ISO-228 WITH OR

MEDIDA MEASURE	PAR ACONSEJADO Nm RECOMMENDED TORQUE Nm	PAR DE ROTURA Nm BREAKING TORQUE Nm
M5	0,08	0,32
1/8	3	8
1/4	9	30
3/8	10	60
1/2	12	50

LOS VALORES DE ROTURA PUEDEN VARIAR EN FUNCIÓN DEL ARTÍCULO
BREAKING VALUES MAY VARY ACCORDING TO THE ITEM



PAR DE APRIETE PARA ROSCAS MACHO "SHORT"
TORQUE TO MALE THREADS "SHORT"

MEDIDA MEASURE	PAR MÍNIMO ACONSEJADO Nm RECOMMENDED MINIMUM TORQUE Nm	PAR MÁXIMO ACONSEJADO Nm RECOMMENDED MAX TORQUE Nm
1/8	5	7
1/4	5	7
3/8	5	7
1/2	5	7

LOS VALORES DE ROTURA PUEDEN VARIAR EN FUNCIÓN DEL ARTÍCULO
BREAKING VALUES MAY VARY ACCORDING TO THE ITEM

Todas las roscas de esta serie (incluyendo la medida de M5) están fabricadas con junta de cierre que permite la inmediata utilización del racor reduciendo notablemente el tiempo de instalación.

All of threads from this range (also the M5), have been equipped with tightening parts which allow the direct assembly of the fittings, reducing the installation time.

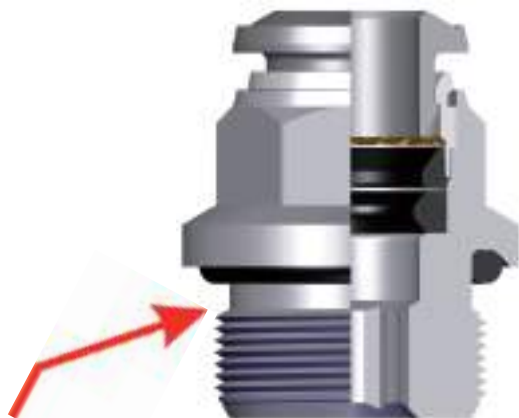

**Junta tórica (O-Ring)
para roscas cilíndricas**
*O-Ring of the parallel
threads.*

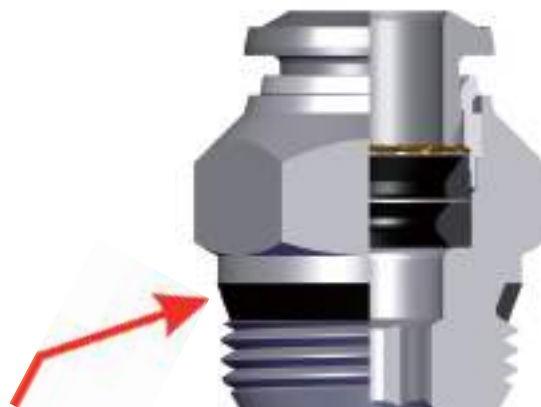

**Junta de cierre para
roscas cónicas "short".**
*Thread packing for the
"short" taper threads.*



Todos los racores rectos, con roscas "short" o cilíndricas, pueden montarse también con llave hexágona y es posible utilizarlos incluso en espacios muy reducidos.

All the straight fittings, with "short" and parallel threads can be assembled also with Allen wrench and it is possible to use them in reduced spaces.

Pinza de sujeción / Clamping washer

La pinza en acero inox garantiza el perfecto agarre del tubo de cualquier material sin perjudicar la superficie.

The washer is made in stainless steel ensures the perfect tube clamping with every kinds of materials without damage the surface.

La conexión entre tubo y racor asegura una estanqueidad total aun en condiciones de impacto o vibración.

The connection between the tube and the fitting ensure a total tightness even in severe conditions such as impact and vibrations.

La particular geometría de la junta garantiza una perfecta estanqueidad incluso en vacío.

The particular geometric shape of the seal ensure the perfect tightness even with vacuum.



57000

RACOR RECTO MACHO CÓNICO (SHORT) - STRAIGHT MALE ADAPTOR (SHORT)

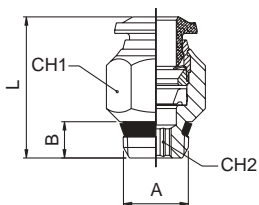

Código Code	Tubo Tube	A	B	L	CH1	CH2	Conf. Pack.
*890000003	4 (5/32)	1/8	5.5	18	11	3	10
*890000004	4 (5/32)	1/4	7	19	14	3	10
570000002	6	1/8	5.5	21.5	13	4	10
570000003	6	1/4	7	21	14	4	10
570000014	6	3/8	7.5	23	17	4	10
570000015	6	1/2	9	23.5	21	4	10
*890000008	8 (5/16)	1/8	5.5	24.5	14	5	10
*890000009	8 (5/16)	1/4	7	22	14	6	10
*890000010	8 (5/16)	3/8	7.5	23	17	6	10
*890000022	8 (5/16)	1/2	9	23.5	21	6	10
570000007	10	1/4	7	28	17	7	10
570000008	10	3/8	7.5	25.5	17	8	10
570000017	10	1/2	9	26	21	8	10
570000009	12	1/4	7	31.5	20	7	10
570000010	12	3/8	7.5	29.5	20	9	10
570000018	12	1/2	9	31.5	21	10	10
570000019	14	3/8	7.5	32.5	21	9	10
570000020	14	1/2	9	31.5	21	10	10

* Artículos en común con la serie 89000 para tubos en pulgadas
 * Items in common with series 89000 for inch tubes

57010

RACOR RECTO MACHO CÓNICO (SHORT) HEXÁGONO INTERIOR - STRAIGHT MALE ADAPTOR (SHORT) WITH EXAGON EMBEDDED

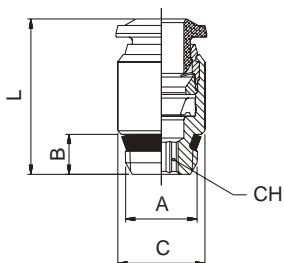

Código Code	Tubo Tube	A	B	C	L	CH	Conf. Pack.
*890100001	4 (5/32)	1/8	7.5	10	19	3	10
570100003	6	1/8	7.5	12	22.5	4	10
570100004	6	1/4	11	14	24.5	4	10
*890100002	8 (5/16)	1/8	7.5	14	25.5	5	10
*890100003	8 (5/16)	1/4	11	14	25	6	10

* Artículos en común con la serie 89000 para tubos en pulgadas
 * Items in common with series 89000 for inch tubes

57010

RACOR RECTO MACHO CÓNICO CILÍNDRICA HEXÁGONO INTERIOR - STRAIGHT MALE ADAPTOR PARALLEL WITH EXAGON EMBEDDED

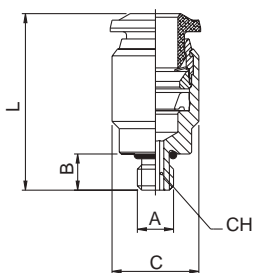

Código Code	Tubo Tube	A	B	C	L	CH	Conf. Pack.
570100001	4	M5	4	10	21	2.5	10
570100009	4	M7x1	5	10	21	2.5	10
570100007	6	M5	4	12	24.5	2.5	10

57020

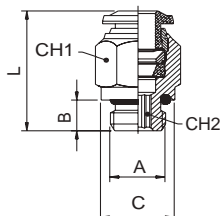
RACOR RECTO MACHO CILÍNDRICO CON TÓRICA - STRAIGHT MALE ADAPTOR (PARALLEL)

Código Code	Tubo Tube	A	B	C	L	CH1	CH2	Conf. Pack.
570200001	4	M5	4	8	21	10	2	10
570200002	4	1/8	6	13	20	10	3	10
570200022	4	1/4	8	16	19.5	16	3	10
570200018	5	M5	4	8	23.5	12	2	10
570200019	5	1/8	6	13	22	12	4	10
570200020	6	M5	4	10	24.5	13	2	10
570200003	6	1/8	6	13	23.5	13	4	10
570200004	6	1/4	8	16	23.5	13	4	10
570200027	6	3/8	9	20	25	13	4	10
570200028	6	1/2	10	25	27	13	4	10
570200005	8	1/8	6	13	25	14	5	10
570200006	8	1/4	8	16	23	14	6	10
570200007	8	3/8	9	20	24	14	6	10
570200029	8	1/2	10	25	26.5	14	6	10
570200008	10	1/4	8	16	30.5	17	6	10
570200009	10	3/8	9	20	27.5	17	8	10
570200031	10	1/2	10	25	27	17	8	10
570200032	12	1/4	8	16	34.5	20	6	10
570200011	12	3/8	9	20	34	20	8	10
570200023	12	1/2	10	25	31	22	10	10
570200024	14	3/8	9	20	35	21	10	10
570200025	14	1/2	10	25	32	22	10	10
570200012	6	M12x1	8	15	23.5	13	4	10
570200013	6	M12x1.25	8	15	23.5	13	4	10
570200014	6	M12x1.5	8	15	23.5	13	4	10
570200017	8	M12x1.5	8	15	27.5	14	6	10

57030

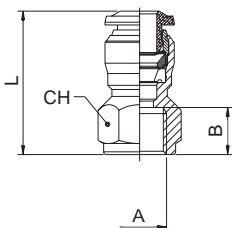
RACOR RECTO HEMBRA - STRAIGHT FEMALE ADAPTOR

Código Code	Tubo Tube	A	B	L	CH	Conf. Pack.
570300008	4	M5	5.5	21	11	10
570300001	4	1/8	8.5	24	13	10
570300009	4	1/4	11	27.5	16	10
570300006	5	1/8	8.5	26.5	13	10
570300002	6	1/8	8.5	26	13	10
570300003	6	1/4	11	29.5	16	10
570300004	8	1/8	8.5	27	15	10
570300005	8	1/4	11	29.5	17	10
570300010	8	3/8	12	32	19	10
570300011	10	1/4	11	32	18	10
570300012	10	3/8	12	33.5	19	10
570300013	10	1/2	15	39	24	10
570300014	12	3/8	12	36	21	10
570300015	12	1/2	15	41	24	10

57040

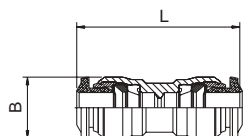
RACOR RECTO INTERMEDIO - STRAIGHT CONNECTOR

Código Code	Tubo Tube	Tubo Tube	L	B	Conf. Pack.
*570400001	4 (5/32)		30.5	10.5	10
570400008	5		33	11.5	10
570400002	6	4	32	12.5	10
570400003	6		34	12.5	10
570400004	8	6	35	14.5	10
*570400005	8 (5/16)		36	14.5	10
570400011	10	8	40.5	17.5	10
570400006	10		42	17.5	10
570400012	12	10	45.5	20.5	10
570400007	12		47	20.5	10
570400010	14		49	21.5	10

* Artículos en común con la serie 89000 para tubos en pulgadas
 * Items in common with series 89000 for inch tubes

57050

RACOR RECTO INTERMEDIO PASATABIQUES - BULKHEAD CONNECTOR

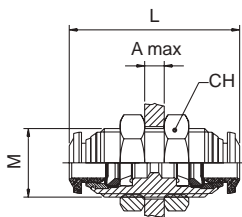

Código Code	Tubo Tube	M	L	CH	A max	Conf. Pack.
*5705000001	4 (5/32)	M12x1	31.5	17	7	10
5705000006	5	M14x1	33	17	7	10
5705000002	6	M14x1	35	17	9.5	10
*5705000003	8 (5/16)	M16x1	37	19	10.5	10
5705000004	10	M20x1	43	24	12.5	10
5705000005	12	M22x1	48	26	16.5	10

* Artículos en común con la serie 89000 para tubos en pulgadas
 * Items in common with series 89000 for inch tubes

57100

RACOR A L MACHO CÓNICO - ELBOW MALE ADAPTOR (TAPER)

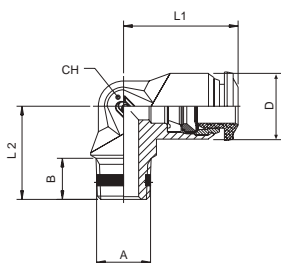

Código Code	Tubo Tube	A	B	L1	L2	CH	D	Conf. Pack.
5710000001	4	M5	5	17	15	9	10	10
5710000002	4	1/8	7.5	17	15.5	9	10	10
5710000010	5	M5	5	20	17	11	12.5	10
5710000011	5	1/8	7.5	20	17.5	11	12.5	10
5710000003	6	1/8	7.5	21	17.5	11	12.5	10
5710000012	6	1/4	11	21	21.5	11	12.5	10
5710000004	8	1/8	7.5	22.5	19	13	14	10
5710000005	8	1/4	11	22.5	21.5	13	14	10
5710000006	10	1/4	11	26.5	24.5	16	17	10
5710000007	10	3/8	11.5	26.5	24	16	17	10
5710000008	12	1/4	11	30.5	28	19	21.5	10
5710000009	12	3/8	11.5	30.5	28	19	21.5	10

57106

RACOR A L ORIENTABLE HEMBRA - ORIENTING ELBOW FEMALE ADAPTOR

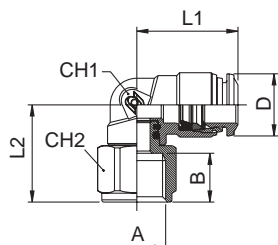

Código Code	Tubo Tube	A	B	L1	L2	CH1	CH2	D	Conf. Pack.
5710600001	4	1/8	8.5	18	20	9	13	10	10
5710600002	4	1/4	11	18	21.5	9	16	10	10
5710600003	6	1/8	8.5	21	20.5	11	13	12.5	10
5710600004	6	1/4	11	21	23	11	16	12.5	10
5710600005	8	1/8	8.5	22.5	20.5	12	13	14.5	10
5710600006	8	1/4	11	22.5	23	12	16	14.5	10

57111

RACOR A L ORIENTABLE MACHO SHORT - ORIENTING ELBOW MALE ADAPTOR (SHORT)

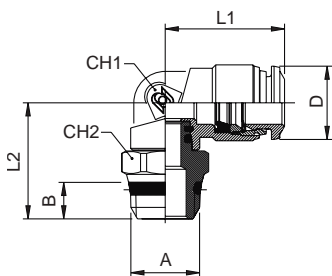

Código Code	Tubo Tube	A	B	L1	L2	CH	CH2	D	Conf. Pack.
*8911100003	4 (5/32)	1/8	5.5	18	19.5	9	13	10	10
*8911100004	4 (5/32)	1/4	7	18	21	9	15	10	10
5711100004	6	1/8	5.5	21	21.5	11	13	12.5	10
5711100005	6	1/4	7	21	23	11	15	12.5	10
*8911100008	8 (5/16)	1/8	5.5	22.5	22.5	12	13	14.5	10
*8911100009	8 (5/16)	1/4	7	22.5	22.5	12	15	14.5	10
*8911100010	8 (5/16)	3/8	7.5	22.5	23	12	17	14.5	10
*8911100018	8 (5/16)	1/2	9	22.5	25.5	12	21	14.5	10
5711100010	10	1/4	7	26.5	26.5	14	16	17.5	10
5711100011	10	3/8	7.5	26.5	24.5	14	17	17.5	10
5711100012	10	1/2	9	26.5	27	14	21	17.5	10
5711100013	12	3/8	7.5	31.5	26.5	16	20	21.5	10
5711100014	12	1/2	9	31.5	29	16	21	21.5	10
5711100015	14	3/8	7.5	31.5	27	16	20	21.5	10
5711100016	14	1/2	9	31.5	29.5	16	21	21.5	10

* Artículos en común con la serie 89000 para tubos en pulgadas
 * Items in common with series 89000 for inch tubes

57116

RACOR A L ORIENTABLE MACHO CILÍNDRICO CON TÓRICA - ORIENTING ELBOW MALE ADAPTOR (PARALLEL)

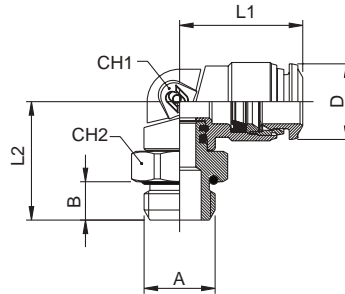

Código Code	Tubo Tube	A	B	L1	L2	CH1	CH2	D	Conf. Pack.
5711600002	4	M5	3.5	18	17.5	9	8	10	10
5711600003	4	1/8	5.5	18	18	9	13	10	10
5711600004	4	1/4	7	18	18	9	16	10	10
5711600005	5	M5	3.5	20	20	11	11	12.5	10
5711600006	5	1/8	5.5	20	20	11	13	12.5	10
5711600007	6	M5	3.5	21	20	11	11	12.5	10
5711600008	6	1/8	5.5	21	20	11	13	12.5	10
5711600009	6	1/4	7	21	21.5	11	16	12.5	10
5711600010	8	1/8	5.5	22.5	21	12	13	14.5	10
5711600011	8	1/4	7	22.5	21.5	12	16	14.5	10
5711600012	8	3/8	8	22.5	23.5	12	20	14.5	10
5711600013	8	1/2	9.5	22.5	25	12	25	14.5	10
5711600014	10	1/4	7	26.5	25.5	14	16	17.5	10
5711600015	10	3/8	8	26.5	25	14	20	17.5	10
5711600016	10	1/2	9.5	26.5	26.5	14	25	17.5	10
5711600025	12	1/4	8	31.5	27.5	16	20	21.5	10
5711600017	12	3/8	8	31.5	27	16	20	21.5	10
5711600018	12	1/2	9.5	31.5	28.5	16	25	21.5	10
5711600019	14	3/8	8	31.5	27.5	16	20	21.5	10
5711600020	14	1/2	9.5	31.5	29	16	25	21.5	10
5711600021	6	M12x1	7.5	20	22	11	16	12.5	10
5711600022	6	M12x1.25	7.5	20	22	11	16	12.5	10
5711600023	6	M12x1.5	7.5	20	22	11	16	12.5	10
5711600024	8	M12x1.5	7.5	22.5	22	12	16	14.5	10

57126

RACOR A L ORIENTABLE PROLONGADO MACHO CILÍNDRICO CON TÓRICA - EXTENDED ORIENTING ELBOW MALE ADAPTOR (PARALLEL)

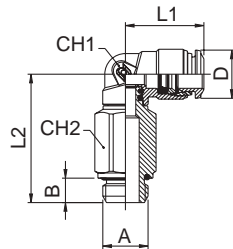

Código Code	Tubo Tube	A	B	L1	L2	CH1	CH2	D	Conf. Pack.
5712600001	4	1/8	5.5	18	30	9	12	10	10
5712600002	4	1/4	7	18	32	9	15	10	10
5712600003	5	1/8	5.5	20	34.5	11	12	12.5	10
5712600004	6	1/8	5.5	21	34.5	11	12	12.5	10
5712600005	6	1/4	7	21	36	11	15	12.5	10
5712600006	8	1/8	5	22.8	37.5	12	12	14.5	10
5712600007	8	1/4	7	22.5	38	12	15	14.5	10
5712600008	8	3/8	8	22.5	40	12	18	14.5	10
5712600009	10	1/4	7	26.5	45	14	16	17.5	10
5712600010	10	3/8	8	26.5	44.5	14	18	17.5	10

57130

RACOR A L INTERMEDIO - ELBOW CONNECTOR

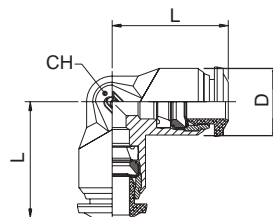

Código Code	Tubo Tube	L	CH	D	Conf. Pack.
*5713000001	4 (5/32)	17	9	10	10
5713000006	5	20	11	12.5	10
5713000002	6	21	11	12.5	10
*5713000003	8 (5/16)	22.5	13	14	10
5713000004	10	26.5	16	17	10
5713000005	12	30.5	19	21.5	10
5713000008	14	32.5	19	21.5	10

* Artículos en común con la serie 89000 para tubos en pulgadas
 * Items in common with series 89000 for inch tubes

57200

RACOR A T MACHO CENTRAL CÓNICO - TEE MALE ADAPTOR (TAPER) CENTRE LEG

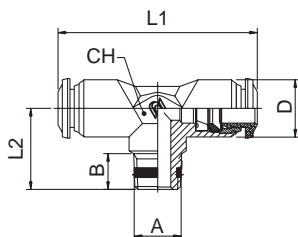

Código Code	Tubo Tube	A	B	L1	L2	CH	D	Conf. Pack.
572000001	4	M5	5	34	15	9	10	10
572000002	4	1/8	7.5	34	15.5	9	10	10
572000010	5	1/8	7.5	40	17.5	11	12.5	10
572000003	6	1/8	7.5	42	17.5	11	12.5	10
572000004	8	1/8	7.5	45	19	13	14	10
572000005	8	1/4	11	45	21.5	13	14	10
572000006	10	1/4	11	53	24.5	16	17	10
572000007	10	3/8	11.5	53	24	16	17	10
572000008	12	1/4	11	61	28	19	21.5	10
572000009	12	3/8	11.5	61	28	19	21.5	10

57211

RACOR A T ORIENTABLE MACHO CENTRAL CILÍNDRICO CON TÓRICA - ORIENTING TEE MALE ADAPTOR (PARALLEL) CENTRE LEG

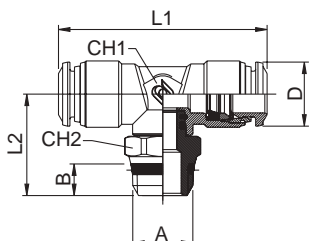

Código Code	Tubo Tube	A	B	L1	L2	CH1	CH2	D	Conf. Pack.
*8921100003	4 (5/32)	1/8	5.5	34	20	9	13	10	10
*8921100004	4 (5/32)	1/4	7	34	21.5	9	15	10	10
5721100004	6	1/8	5.5	42	22	11	13	12.5	10
5721100005	6	1/4	7	42	23.5	11	15	12.5	10
*8921100016	8 (5/16)	1/8	5.5	45	25.5	13	13	14.5	10
*8921100015	8 (5/16)	1/4	7	45	25.5	13	15	14.5	10
*8921100017	8 (5/16)	3/8	7.5	45	26	13	17	14.5	10
5721100010	10	1/4	7	53	29	14	16	17.5	10
5721100011	10	3/8	7.5	53	27	14	17	17.5	10
5721100012	10	1/2	9	53	29.5	14	21	17.5	10
5721100013	12	3/8	7.5	62.6	29.5	16	20	21.5	10
5721100014	12	1/2	9	62.6	32	16	21	21.5	10

* Artículos en común con la serie 89000 para tubos en pulgadas
 * Items in common with series 89000 for inch tubes

57216

RACOR A T ORIENTABLE MACHO LATERAL CILÍNDRICO CON TÓRICA - ORIENTING TEE MALE ADAPTOR (PARALLEL) OFF - SET LEG

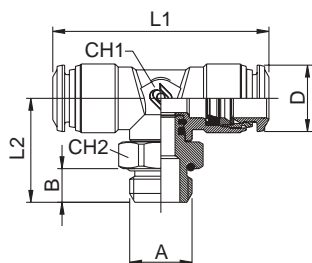

Código Code	Tubo Tube	A	B	L1	L2	CH1	CH2	D	Conf. Pack.
5721600002	4	M5	3.5	34	18	9	8	10	10
5721600003	4	1/8	5.5	34	18.5	9	13	10	10
5721600004	4	1/4	7	34	20	9	16	10	10
5721600005	5	M5	3.5	40	20.5	11	11	12.5	10
5721600006	5	1/8	5.5	40	20.5	11	13	12.5	10
5721600007	6	M5	3.5	42	20.5	11	11	12.5	10
5721600008	6	1/8	5.5	42	20.5	11	13	12.5	10
5721600009	6	1/4	7	42	22	11	16	12.5	10
5721600010	8	1/8	5.5	45	23.5	13	13	14.5	10
5721600011	8	1/4	7	45	24	13	16	14.5	10
5721600012	8	3/8	8	45	26	13	20	14.5	10
5721600013	8	1/2	9.5	45	27.5	13	25	14.5	10
5721600014	10	1/4	7	53	27.5	14	16	17.5	10
5721600015	10	3/8	8	53	27	14	20	17.5	10
5721600016	10	1/2	9.5	53	28.5	14	25	17.5	10
5721600017	12	3/8	8	62.5	29.5	16	20	21.5	10
5721600018	12	1/2	9.5	62.5	31	16	25	21.5	10
5721600019	14	3/8	8	62.5	29.5	16	20	21.5	10
5721600020	14	1/2	9.5	62.5	31	16	25	21.5	10
5721600021	6	M12x1	7.5	42	22	11	16	12.5	10
5721600022	6	M12x1.25	7.5	42	22	11	16	12.5	10
5721600023	6	M12x1.5	7.5	42	22	11	16	12.5	10

57223

RACOR A T ORIENTABLE MACHO LATERAL CÓNICO (SHORT) - ORIENTING TEE MALE ADAPTOR (SHORT) OFF - SET LEG

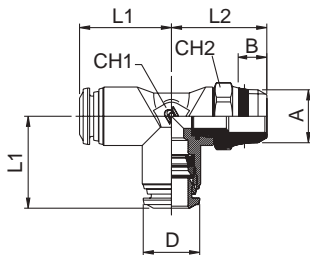

Código Code	Tubo Tube	A	B	L1	L2	CH1	CH2	D	Conf. Pack.
*8922300003	4 (5/32)	1/8	5.5	17	20	9	13	10	10
*8922300004	4 (5/32)	1/4	7	17	21.5	9	15	10	10
5722300004	6	1/8	5.5	21	22	11	13	12.5	10
5722300005	6	1/4	7	21	23.5	11	15	12.5	10
*8922300015	8 (5/16)	1/8	5.5	22.5	24	13	13	14.5	10
*8922300016	8 (5/16)	1/4	7	22.5	24	13	15	14.5	10
*8922300017	8 (5/16)	3/8	7.5	22.5	27	13	17	14.5	10
5722300010	10	1/4	7	26.5	26	14	16	17.5	10
5722300011	10	3/8	7.5	26.5	26	14	17	17.5	10
5722300012	10	1/2	9	26.5	28.5	14	21	17.5	10
5722300013	12	3/8	7.5	31.5	29.5	16	20	21.5	10
5722300014	12	1/2	9	31.5	32	16	21	21.5	10

* Artículos en común con la serie 89000 para tubos en pulgadas
 * Items in common with series 89000 for inch tubes

57226

RACOR A T ORIENTABLE MACHO LATERAL CILÍNDRICO CON TÓRICA - ORIENTING TEE MALE ADAPTOR (PARALLEL) OFF - SET LEG

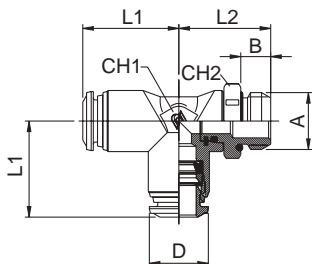

Código Code	Tubo Tube	A	B	L1	L2	CH1	CH2	D	Conf. Pack.
5722600002	4	M5	3.5	17	18	9	8	10	10
5722600003	4	1/8	5.5	17	18.5	9	13	10	10
5722600004	4	1/4	7	17	20	9	16	10	10
5722600005	5	M5	3.5	20	20.5	11	11	12.5	10
5722600006	5	1/8	5.5	20	20.5	11	13	12.5	10
5722600007	6	M5	3.5	21	20.5	11	11	12.5	10
5722600008	6	1/8	5.5	21	20.5	11	13	12.5	10
5722600009	6	1/4	7	21	22	11	16	12.5	10
5722600010	8	1/8	5.5	22.5	22.5	13	13	14.5	10
5722600011	8	1/4	7	22.5	23	13	16	14.5	10
5722600012	8	3/8	8	22.5	25	13	20	14.5	10
5722600013	8	1/2	9.5	22.5	26.5	13	25	14.5	10
5722600014	10	1/4	7	26.5	27	14	16	17.5	10
5722600015	10	3/8	8	26.5	26.5	14	20	17.5	10
5722600016	10	1/2	9.5	26.5	28	14	25	17.5	10
5722600017	12	3/8	8	31.5	29.5	16	20	21.5	10
5722600018	12	1/2	9.5	31.5	31	16	25	21.5	10
5722600021	6	M12x1	7.5	21	22	11	16	12.5	10
5722600022	6	M12x1.25	7.5	21	22	11	16	12.5	10
5722600023	6	M12x1.5	7.5	21	22	11	16	12.5	10

57230

RACOR A T INTERMEDIO - TEE CONNECTOR

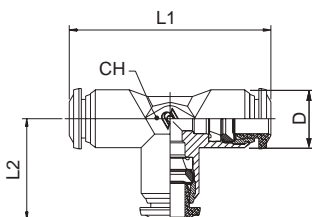

Código Code	Tubo Tube	L1	L2	CH	D	Conf. Pack.
*5723000001	4 (5/32)	34	17	9	10	10
5723000006	5	40	20	11	12.5	10
5723000002	6	42	21	11	12.5	10
*5723000003	8 (5/16)	45	22.5	13	14	10
5723000004	10	53	26.5	16	17	10
5723000005	12	61	30.5	19	21.5	10
5723000008	14	65.5	32.5	19	21.5	10

* Artículos en común con la serie 89000 para tubos en pulgadas
 * Items in common with series 89000 for inch tubes

57310

RACOR A Y INTERMEDIO - Y CONNECTOR

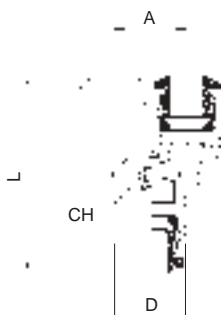

Código Code	Tubo Tube	A	L	CH	D	Conf. Pack.
*5731000001	4 (5/32)	11	32	11	10	10
5731000004	5	13.5	35	13	12.5	10
5731000002	6	13.5	36.5	13	12.5	10
*5731000003	8 (5/16)	15.5	41	15	14	10
5731000008	10	18.5	48	18	17	10

* Artículos en común con la serie 89000 para tubos en pulgadas
 * Items in common with series 89000 for inch tubes

57500

ANILLO ORIENTABLE SIMPLE - SINGLE BANJO BODY



Código Code	Tubo Tube	A	B	L	CH	D	Conf. Pack.
575000001	4 (5/32) M5 (10/32)	12.5	19	-	10	10	10
575000002	4 M6	12.5	19	-	10	10	10
575000003	4 (5/32) 1/8	15	21	14	10	10	10
575000013	5 M5	12.5	20	-	12.5	10	10
575000017	5 M6	12.5	20	-	12.5	10	10
575000014	5 1/8	15	21.5	14	12.5	10	10
575000015	5 1/4	17	24.5	18	12.5	10	10
575000016	6 M5	12.5	20.5	-	12.5	10	10
575000018	6 M6	12.5	20.5	-	12.5	10	10
575000004	6 1/8	15	22	14	12.5	10	10
575000005	6 1/4	17	25	18	12.5	10	10
575000006	8 1/8	15	24	14	14	10	10
575000007	8 1/4	17	26	18	14	10	10
575000008	8 3/8	20	28	21	14	10	10
575000009	10 1/4	17	29	18	17	10	10
575000010	10 3/8	20	30.5	21	17	10	10
575000012	12 3/8	20	32.5	21	21.5	10	10
575000021	12 1/2	24	35	25	21.5	10	10
575000022	14 1/2	24	35.5	25	21.5	10	10

* Artículos en común con la serie 89000 para tubos en pulgadas
 * Items in common with series 89000 for inch tubes

57510

ANILLO ORIENTABLE DOBLE - DOUBLE BANJO BODY



Código Code	Tubo Tube	A	B	L	CH	D	Conf. Pack.
575100001	4 M5	12.5	38	-	10	10	10
575100002	4 M6	12.5	38	-	10	10	10
575100003	4 1/8	15	42	14	10	10	10
575100008	5 1/8	15	43	14	12.5	10	10
575100009	5 1/4	17	49	18	12.5	10	10
575100004	6 1/8	15	44	14	12.5	10	10
575100005	6 1/4	17	50	18	12.5	10	10
575100006	8 1/8	15	48	14	14	10	10
575100007	8 1/4	17	52	18	14	10	10

57550

RACOR ORIENTABLE SIMPLE CON TÓRICA - ORIENTING SINGLE BANJO BODY MALE

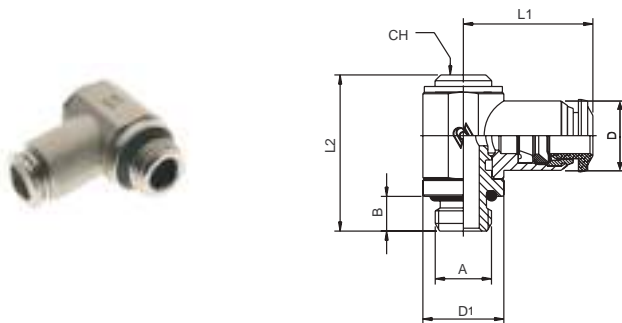

Código Code	Tubo Tube	A	B	L1	L2	CH	D1	D	Conf. Pack.
575500001	4 M5	5	19	24.5	-	9	10	10	10
575500002	4 1/8	6	21	28	5	14	10	10	10
575500012	5 M5	5	20	24.5	-	9	12.5	10	10
575500013	5 1/8	6	21.5	28	5	14	12.5	10	10
575500014	5 1/4	8	24.5	31	6	18	12.5	10	10
575500015	6 M5	5	20.5	24.5	-	9	12.5	10	10
575500003	6 1/8	6	22.5	28	5	14	12.5	10	10
575500004	6 1/4	8	25	31	6	18	12.5	10	10
575500005	8 1/8	6	24	28	5	14	14	10	10
575500006	8 1/4	8	26	31	6	18	14	10	10
575500007	8 3/8	9	28	35.5	7	21	14	10	10
575500008	10 1/4	8	29	31	6	18	17	10	10
575500009	10 3/8	9	30.5	35.5	7	21	17	10	10
575500011	12 3/8	9	32.5	35.5	7	21	21.5	10	10

57560

RACOR ORIENTABLE DOBLE CON TÓRICA - ORIENTING DOUBLE BANJO BODY MALE

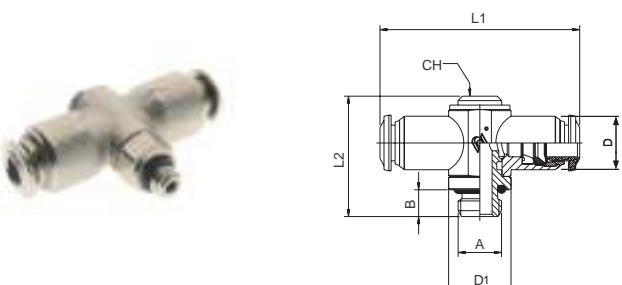

Código Code	Tubo Tube	A	B	L1	L2	D1	CH	D	Conf. Pack.
575600002	4 1/8	6	42	27	14	5	10	10	10
575600008	5 1/8	6	43	27	14	5	12.5	10	10
575600009	5 1/4	8	49	31	18	6	12.5	10	10
575600003	6 1/8	6	45	27	14	5	12.5	10	10
575600004	6 1/4	8	50	31	18	6	12.5	10	10
575600005	8 1/8	6	48	27	14	5	14	10	10
575600006	8 1/4	8	52	31	18	6	14	10	10

51410

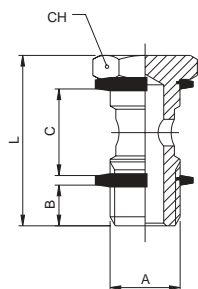
TORNILLO SIMPLE - BANJO STEM SINGLE

Código Code	A	B	C	L	CH	Conf. Pack.
5141000011	M5	4	12.5	22	8	25
5141000012	M6	5	12.5	23	8	25
5141000013	1/8	6	15	28	14	25
5141000014	1/4	8	17	32	17	25
5141000015	3/8	9	20	36	19	25
5141000016	1/2	10	24	42	24	25
5141000017	*M12x1.5	8	17	32	17	25

ESTE ARTÍCULO VIENE COMPLETO DE ARANDELAS EN NYLON (ART.1610).
THIS ITEM WILL BE SUPPLIED WITH THE NYLON WASHERS (ART. 1610).

*CON ESTE TORNILLO UTILIZAR EL ANILLO ORIENTABLE DE 1/4.
*WITH THIS BANJO STEM USING 1/4 ORIENTING BANJO BODY.

51420

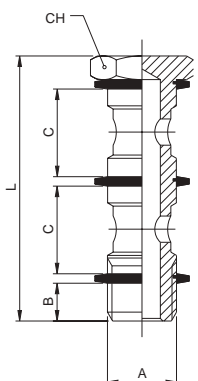
TORNILLO DOBLE - BANJO STEM DOUBLE

Código Code	A	B	C	L	CH	Conf. Pack.
5142000011	1/8	6	15	44.5	14	25
5142000012	1/4	8	17	50.5	17	25
5142000013	3/8	9	20	58	19	25
5142000014	1/2	10	24	68	24	25
5142000015	*M12x1.5	8	17	50.5	17	25

ESTE ARTÍCULO VIENE COMPLETO DE ARANDELAS EN NYLON (ART.1610).
THIS ITEM WILL BE SUPPLIED WITH THE NYLON WASHERS (ART. 1610).

*CON ESTE TORNILLO UTILIZAR EL ANILLO ORIENTABLE DE 1/4.
*WITH THIS BANJO STEM USING 1/4 ORIENTING BANJO BODY.

51430

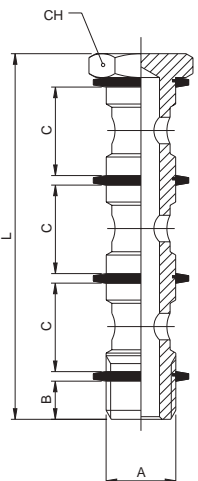
TORNILLO TRIPLE - BANJO STEM TRIPLE

Código Code	A	B	C	L	CH	Conf. Pack.
5143000011	1/8	6	15	61	14	25
5143000012	1/4	8	17	69	17	25
5143000013	3/8	9	20	80	19	25
5143000014	1/2	10	24	94	24	10

ESTE ARTÍCULO VIENE COMPLETO DE ARANDELAS EN NYLON (ART.1610).
THIS ITEM WILL BE SUPPLIED WITH THE NYLON WASHERS (ART. 1610).

51440

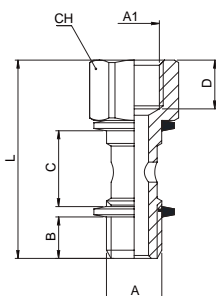
TORNILLO SIMPLE MACHO - HEMBRA - MALE - FEMALE BANJO STEM SINGLE

Código Code	A	A1	B	C	D	L	CH	Conf. Pack.
5144000001	1/8	1/8	6	15	8.5	34.5	14	25
5144000002	1/4	1/4	8	17	11	40.5	17	25
5144000003	3/8	3/8	9	20	12	45.5	19	25

ESTE ARTÍCULO VIENE COMPLETO DE ARANDELAS EN NYLON (ART.1610).
THIS ITEM WILL BE SUPPLIED WITH THE NYLON WASHERS (ART. 1610).

50600

ADAPTADOR MACHO CILÍNDRICO CON TÓRICA - MALE ADAPTOR PARALLEL

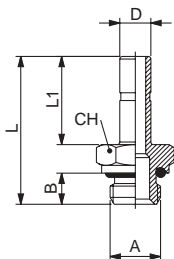

Código Code	D	A	B	L	L1	CH	Conf. Pack.
506000001	4	M5	4	24	15	8	10
506000002	4	1/8	6	26.5	15	13	10
506000012	5	M5	4	26	17	8	10
506000013	5	1/8	6	28.5	17	13	10
506000014	5	1/4	8	31	17	16	10
506000015	6	M5	4	26	17	8	10
506000003	6	1/8	6	28.5	17	13	10
506000004	6	1/4	8	31	17	16	10
506000005	8	1/8	6	29.5	18	13	10
506000006	8	1/4	8	32	18	16	10
506000007	8	3/8	9	33.5	18	20	10
506000016	10	1/8	6	33.5	22	13	10
506000008	10	1/4	8	36	22	16	10
506000009	10	3/8	9	37.5	22	20	10
506000010	12	1/4	8	38.5	24.5	16	10
506000011	12	3/8	9	40	24.5	20	10

8610

TAPÓN - PLUG

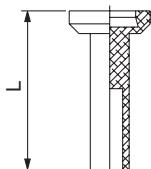

Código Code	Tubo Tube	L	Conf. Pack.
086100031X0RO	3	18	25
086100031X1RO	4	23.5	25
086100031X3RO	5	24.5	25
086100031X4RO	6	24.5	25
086100031X7RO	8	26	25
086100031X9RO	10	28.5	25
086100031Y1RO	12	28.5	25
086100031Y3RO	14	28.5	20

50625

UNIÓN DOBLE - DOUBLE JOINT

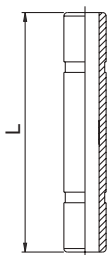

Código Code	Tubo Tube	L	Conf. Pack.
506250001X1NB	4	31	10
506250001X3NB	5	33	10
506250001X4NB	6	34	10
506250001X7NB	8	36	10
506250001X9NB	10	45	10
506250001Y1NB	12	50	10

57700

REDUCCIÓN - REDUCER

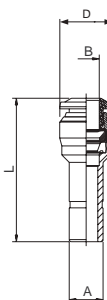

Código Code	A	B	L	D	Conf. Pack.
577000004	5	4	29	12.5	10
577000001	6	4	30	12.5	10
577000005	6	5	32	12.5	10
577000008	8	4	33	14	10
577000002	8	6	34	14	10
577000009	10	4	32	17	10
577000003	10	8	38	17	10
577000007	12	8	39	21.5	10
577000010	12	10	43	17.5	10

57800

CARTUCHO A COMPRESIÓN - PUSH-FIT CARTRIDGES

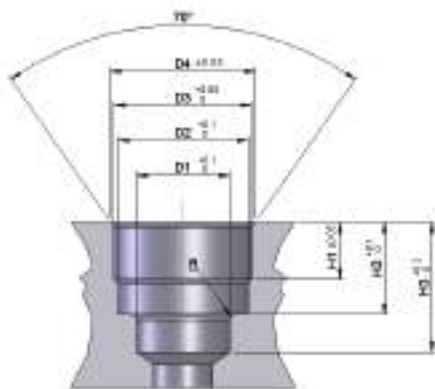
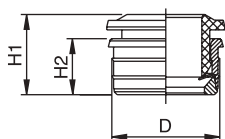

Código Code	Tubo Tube	D	H1	H2	Conf. Pack.
5780000001	4	8.7	10.4	5.6	25
5780000002	5	9.75	11.8	6.3	25
5780000003	6	10.75	12.4	6.9	25
5780000004	8	12.7	12.4	6.9	25
5780000005	10	15.7	15.7	8.5	25
5780000006	12	18.3	17.8	9.5	25

57800

SEDE - SEAT

DIMENSIONES SEDE CARTUCHO A COMPRESIÓN
SEATS DIMENSIONS PUSH-FIT CARTRIDGES

Tubo Tube	D1	D2	D3	D4	H1	H2	H3	R
4	4.2	7.45	8.4	9	3.75	6.5	9.5	0.5
5	5.2	8.35	9.4	10.15	4.45	7.9	10.5	0.5
6	6.2	9.35	10.45	11.35	5	8.5	11.5	0.5
8	8.2	11.4	12.4	12.9	5.2	8.5	12.5	0.75
10	10.2	14.5	15.4	16	6.7	10.5	15	0.75
12	12.2	17	18	19	7.5	12.1	17	1

55801

FRESA SEDE CARTUCHO A COMPRESIÓN
TOOL FOR PUSH-FIT CARTRIDGES SEAT



Código Code	Tubo Tube	Ø Cuerpo Ø Body	Conf. Pack.
5580100001	4	10	1
5580100006	5	12	1
5580100002	6	12	1
5580100003	8	12	1
5580100004	10	16	1
5580100005	12	16	1

55802

ÚTIL DE MONTAJE CARTUCHO A COMPRESIÓN
ASSEMBLING TOOL FOR PUSH-FIT CARTRIDGES



Código Code	Tubo Tube	Conf. Pack.
5580200002	4	1
5580200003	5	1
5580200004	6	1
5580200005	8	1
5580200006	10	1
5580200007	12	1

INSTRUCCIONES DE MONTAJE CARTUCHO A COMPRESIÓN ART.57800 PUSH-FIT CARTRIDGES ASSEMBLING INSTRUCTIONS ART. 57800

Realizar la sede para el cartucho utilizando la correspondiente fresa Art. 55801.

Make the seat for the cartridge utilizing the suitable tool Art. 55801.



2

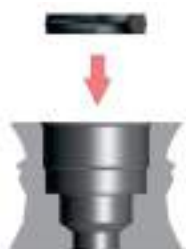

Insertar la junta de labio en la correspondiente sede.
Insert the lip seal inside of the seat.

Insertar el cartucho en el útil de montaje Art. 55802

Insert the cartridge into the assembling tool Art. 55802



3

Empujar el cartucho al interior de la sede hasta llegar al plano con el útil de montaje.

Press the cartridge inside of the seat until it will be reached the abutment surface with the assembling tool.

4



50990

LLAVE DE DESMONTAJE - ALUMINIUM MANIFOLD 5 WAYS

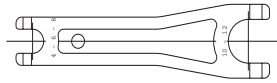

Código Code	Conf. Pack.
5099000001	10

50006

JUNTA DE CIERRE PARA ROSCAS CÓNICAS - THREAD PACKING FOR TAPER THREADS



Código Code	Rosca Thread	Conf. Pack.
5000600240200	1/8	10
5000600240300	1/4	10
5000600240400	3/8	10
5000600240500	1/2	10



70000



Certified to NSF/ANSI-61
NSF-61

Serie 70000

RACORDAJE AUTOMÁTICO FOOD GRADE
FOOD GRADE PUSH-IN FITTINGS

Características Técnicas / Technical Characteristics

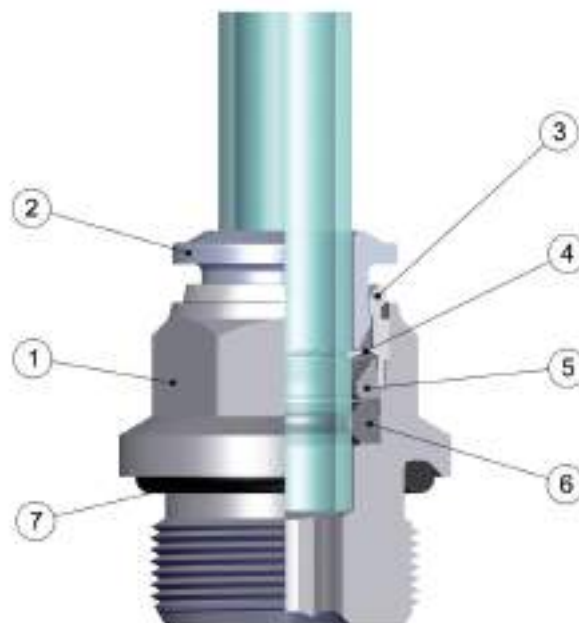

Materiales y Componentes / Component Parts and Materials

- | | |
|---|--|
| <ul style="list-style-type: none"> 1 Cuerpo en latón niquelado Food Grade 2 Anillo de extracción tubo en latón niquelado Food Grade 3 Cápsula en latón niquelado Food Grade 4 Pinza de agarre en acero inox aisi 301 5 Anillo de seguridad en PTFE 6 Junta tórica O-Ring en FKM Alimentaria 7 Junta rosca en FKM Alimentaria | <ul style="list-style-type: none"> 1 Nickel-plated brass Body Food Grade 2 Nickel-plated brass Collet Food Grade 3 Nickel-plated brass Capsule Food Grade 4 Steel aisi 301 Clamping washer 5 PTFE Safety ring 6 Food FKM O-Ring 7 Food FKM Thread packing |
|---|--|

Presiones / Pressures

Presión mínima / Minimum pressure: **-0.99 bar (-0.099 MPa)**
 Presión máxima / Maximum pressure: **15 bar (1.5 MPa)**

Roscas / Threads

Gas cilíndrica conforme ISO 228 Clase A / Parallel gas in conformity with ISO 228 Class A.
Gas cónica conforme ISO 7.1, BS 21, DIN 2999 / Tapered gas in conformity with ISO 7.1, BS 21, DIN 2999.
Métrica conforme ISO R/262 / Metric in conformity with ISO R/262.

Tubos de conexión / Connection Tubes

Tubos en material plástico:
PA6, PA11, PA12, PTFE, Polietileno, *Poliuretano;etc.
 *Para tubos en poliuretano es aconsejada una dureza de 98 shore.
 Plastic tubes:
 PA6, PA11, PA12, PTFE, Polyethylene, *Polyurethane, ecc.
 *For Polyurethane hoses it is required a minimum hardness of 98 shore.

Fluidos compatibles / Fluids

Aire comprimido / Compressed air.
Vacío / Vacuum
Vapor / Steam
Agua potable y alimentos / Drink Water and foods

Temperaturas / Temperatures

Temperatura mínima / Minimum temperature: **-15 °C**
 Temperatura máxima / Maximum temperature: **+200 °C**

Par de apriete / Torque specifications



PAR DE APRIETE PARA ROSCAS MACHO ISO 228 CON TÓRICA
TORQUE TO MALE THREADS ISO-228 WITH OR

MEDIDA MEASURE	PAR ACONSEJADO Nm RECOMMENDED TORQUE Nm	PAR DE ROTURA Nm BREAKING TORQUE Nm
M5	0,08	0,32
1/8	3	8
1/4	9	30
3/8	10	60
1/2	12	50

LOS VALORES DE ROTURA PUEDEN VARIAR EN FUNCIÓN DEL ARTÍCULO
BREAKING VALUES MAY VARY ACCORDING TO THE ITEM

Roscas / Threads

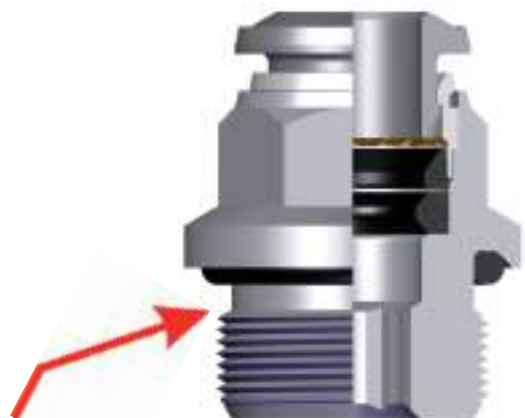

**Junta tórica (O-Ring)
para roscas cilíndricas**
*O-Ring of the parallel
threads.*

Todas las roscas de esta serie (incluyendo la medida de M5) están fabricadas con junta de cierre que permite la inmediata utilización del racor reduciendo notablemente el tiempo de instalación.

All of threads from this range (also the M5), have been equipped with tightening parts which allow the direct assembly of the fittings, reducing the installation time.



Todos los racores rectos, con roscas cónicas o cilíndricas, pueden montarse también con llave hexagonal y es posible utilizarlos incluso en espacios muy reducidos.

All the straight fittings, with "short" and parallel threads can be assembled also with Allen wrench and it is possible to use them in reduced spaces.

Pinza de sujeción / Clamping washer

La pinza en acero inox garantiza el perfecto agarre del tubo de cualquier material sin perjudicar la superficie.

The washer is made in stainless steel ensures the perfect tube clamping with every Kinds of materials without damage the surface.

La conexión entre tubo i racor asegura una estanqueidad total aun en condiciones de impacto y vibración.

The connection between the tube and the fitting ensure a total tightness even in severe conditions such as impact and vibrations.

La particular geometría de la junta garantiza una perfecta estanqueidad incluso en vacío.

The particular geometric shape of the seal ensure the perfect tightness even with vacuum.

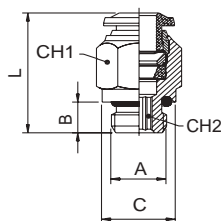

70020

RACOR RECTO MACHO CILÍNDRICO - STRAIGHT MALE ADAPTOR (PARALLEL)

Código Code	Tubo Tube	A	B	C	L	CH1	CH2	Conf. Pack.
700200001	4	M5	4	8	21	10	2	25
700200002	4	1/8	6	13	20	10	3	25
700200003	6	1/8	6	13	23.5	13	4	25
700200004	6	1/4	8	16	23.5	13	4	25
700200005	8	1/8	6	13	25	14	5	25
700200006	8	1/4	8	16	23	14	6	25
700200008	10	1/4	8	16	30.5	17	6	25
700200009	10	3/8	9	20	27.5	17	8	25
700200011	12	3/8	9	20	34	20	8	25

70040

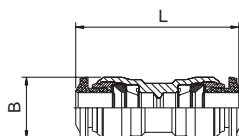
RACOR RECTO INTERMEDIO - STRAIGHT CONNECTOR

Código Code	Tubo Tube	L	B	Conf. Pack.
700400002	4	30.5	10.5	25
700400005	6	34	12.5	25
700400007	8	36	14.5	25
700400009	10	42	17.5	25
700400011	12	47	20.5	25

70116

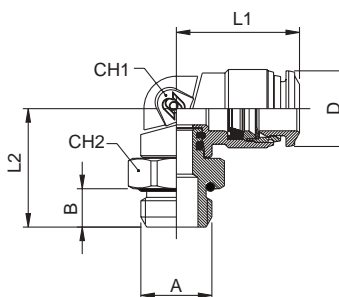
RACOR A L ORIENTABLE MACHO CILÍNDRICO - ORIENTING ELBOW MALE ADAPTOR (PARALLEL)

Código Code	Tubo Tube	A	B	L1	L2	CH1	CH2	D	Conf. Pack.
701160002	4	M5	3.6	18	16.1	9	8	10	25
701160003	4	1/8	5.4	18	16.4	9	13	10	25
701160008	6	1/8	5.4	21	18.1	11	13	12.5	25
701160009	6	1/4	7.1	21	19.8	11	16	12.5	25
701160010	8	1/8	5.4	22.5	20.1	12	13	14.5	25
701160011	8	1/4	7.1	22.5	20.3	12	16	14.5	25
701160014	10	1/4	7.1	26.5	24.3	14	16	17.5	25
701160015	10	3/8	8.1	26.5	23.8	14	20	17.5	25
701160017	12	3/8	8.1	31.3	25.8	16	20	21.5	25

70216

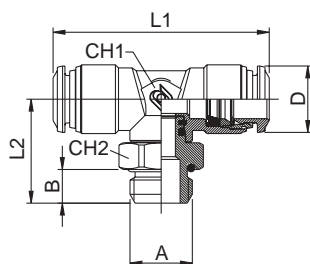
RACOR A T ORIENTABLE MACHO CILÍNDRICO - ORIENTING TEE MALE ADAPTOR (PARALLEL) CENTRE LEG

Código Code	Tubo Tube	A	B	L1	L2	CH1	CH2	D	Conf. Pack.
702160003	4	1/8	5.4	34	17.1	9	13	10	25
702160008	6	1/8	5.4	42	18.4	11	13	12.5	25
702160009	6	1/4	7.1	42	20	11	16	12.5	25
702160010	8	1/8	5.4	45	22.7	13	13	14.5	25
702160011	8	1/4	7.1	45	23	13	16	14.5	25

70230

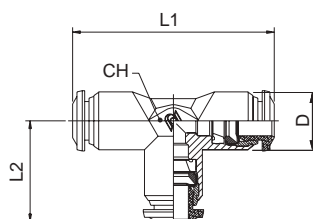
RACOR A T INTERMEDIO - TEE CONNECTOR

Código Code	Tubo Tube	L1	L2	CH	D	Conf. Pack.
702300002	4	34	17	9	10	25
702300004	6	42	21	11	12.5	25
702300005	8	45	22.5	13	14	25
702300006	10	53	26.5	16	17	25
702300007	12	61	30.5	19	21.5	10

Artículos disponibles bajo demanda / Articles available on request

70010

RACOR RECTO MACHO SHORT
HEXÁGONO INTERIOR
STRAIGHT MALE ADAPTOR
(SHORT) WITH EXAGON
EMBEDDED



70030

RACOR RECTO HEMBRA
STRAIGHT FEMALE ADAPTOR



70050

RACOR RECTO INTERMEDIO
PASATABIQUES BULKHEAD
CONNECTOR



70100

RACOR A L MACHO CÓNICO
ELBOW MALE ADAPTOR (TAPER)



70106

RACOR A L HEMBRA
ORIENTABLE
ORIENTING ELBOW FEMALE
ADAPTOR



70126

RACOR A L ORIENTABLE
PROLONGADO MACHO
CILÍNDRICO
EXTENDED ORIENTING ELBOW
MALE ADAPTOR (PARALLEL)



70200

RACOR A T MACHO CÓNICO
TEE MALE ADAPTOR (TAPER)
CENTRE LEG



70226

RACOR A T ORIENTABLE
MACHO LATERAL
CILÍNDRICO ORIENTING TEE
MALE ADAPTOR (PARALLEL)
OFF - SET LEG



70310

RACOR A Y INTERMEDIO
Y CONNECTOR



70500

ANILLO ORIENTABLE SIMPLE
SINGLE BANJO BODY



70505

ANILLO ORIENTABLE SIMPLE
SINGLE BANJO BODY



70510

ANILLO ORIENTABLE DOBLE
DOUBLE BANJO BODY



70550

RACOR A L ORIENTABLE
MACHO CILÍNDRICO
ORIENTING SINGLE BANJO
BODY MALE



70560

RACOR A T ORIENTABLE
MACHO CILÍNDRICO
ORIENTING DOUBLE BANJO
BODY MALE



70700

REDUCCIÓN
REDUCER





60000
61000
62000
63000

Serie INOX

SERIE 60000 - RACORDAJE AUTOMÁTICO EN ACERO INOXIDABLE
STAINLESS STEEL PUSH-IN FITTINGS

SERIE 61000 - RACORDAJE RÁPIDO EN ACERO INOXIDABLE
STAINLESS STEEL PUSH-ON FITTINGS

SERIE 62000 - ACCESORIOS EN ACERO INOXIDABLE
STAINLESS STEEL ACCESSORIES

SERIE 63000 - MULTIPRESA EN ACERO INOXIDABLE
STAINLESS STEEL MULTISOKET

RACORDAJE AUTOMÁTICO EN ACERO INOXIDABLE STAINLESS STEEL PUSH-IN FITTINGS

SERIE 60000

Características Técnicas / Technical Characteristics

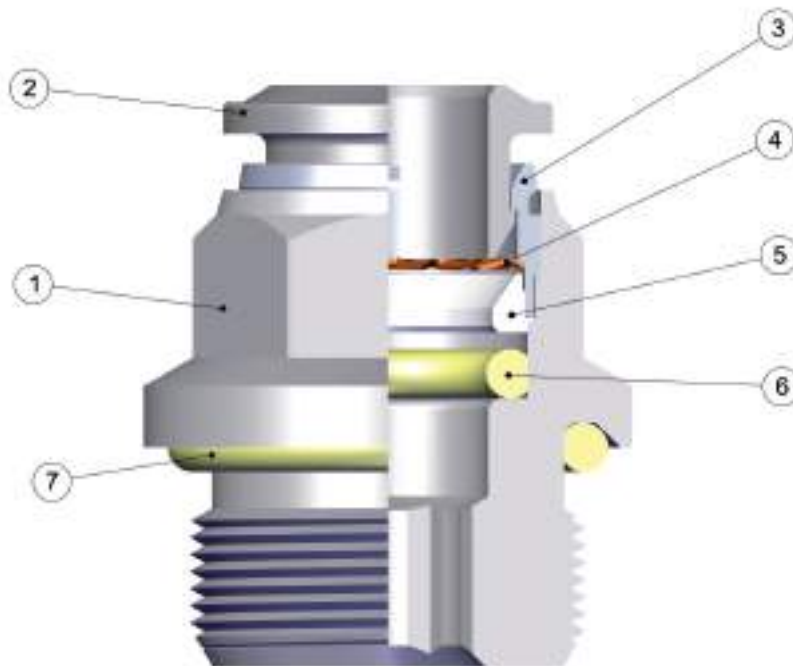

Materiales y Componentes / Component Parts and Materials

- | | |
|---|-----------------------------------|
| 1 Cuerpo en Acero inox. AISI 316L | 1 Aisi 316L Steel Body |
| 2 Anillo de extracción en Acero inox. AISI 316L | 2 Aisi 316L Steel Collet |
| 3 Cápsula en Acero inox. AISI 316L | 3 Aisi 316L Steel Capsule |
| 4 Pinza de agarre en Acero inox. AISI 316L | 4 Aisi 316L Steel Clamping washer |
| 5 Anillo de seguridad en PTFE | 5 Teflon Safety ring |
| 6 Junta de labio en FKM alimentaria | 6 Food FKM Lip seal |
| 7 Junta rosca en FKM alimentaria | 7 Food FKM Thread packing |

Presiones / Pressures

Presión mínima / Minimum pressure: **-0.99 bar** (-0.099 MPa)
Presión máxima / Maximum pressure: **15 bar** (1.5 MPa)

Temperaturas / Temperatures

Temperatura mínima / Minimum temperature: **-20 °C**
Temperatura máxima / Maximum temperature: **+225 °C**

Roscas / Threads

Gas cónica conforme ISO 7.1, BS 21, DIN 2999 / Tapered gas in conformity with ISO 7.1, BS 21, DIN 2999.

Gas cilíndrica conforme ISO 228 Clase A / Parallel gas in conformity with ISO 228 Class A.

Métrica conforme ISO R/262 / Metric in conformity with ISO R/262.

Fluidos compatibles / Fluids

Aire comprimido - Vacío.

Fluidos para industria alimentaria y química compatibles con los componentes del racor.

Compressed air - Vacuum.

Fluid for food and chemical industry compatible with fitting components.

Tubos de conexión / Connection Tubes

Tubos en material plástico:

PA6, PA11, PA12, Polietileno, *Poliuretano, PTFE, FEP

*Para tubos en poliuretano es aconsejada una dureza de 98 shore.

Tube in general.

PA6, PA11, PA12, Polyethylene, *Polyurethane, PTFE, FEP

*For Polyurethane hoses it is required a minimum hardness of 98 shore.

Roscas / Threads

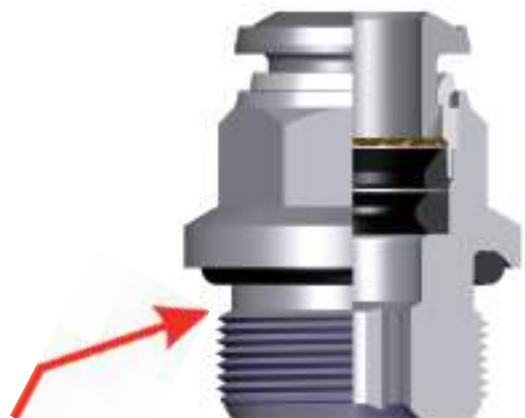

Junta tórica (O-Ring) para las roscas cilíndricas
O-Ring of the parallel threads.

Todas las roscas de esta serie (incluyendo la medida de M5) están fabricadas con junta de cierre que permite la inmediata utilización del racor reduciendo notablemente el tiempo de instalación.

All of threads from this range (also the M5), have been equipped with tightening parts which allow the direct assembly of the fittings, reducing the installation time.

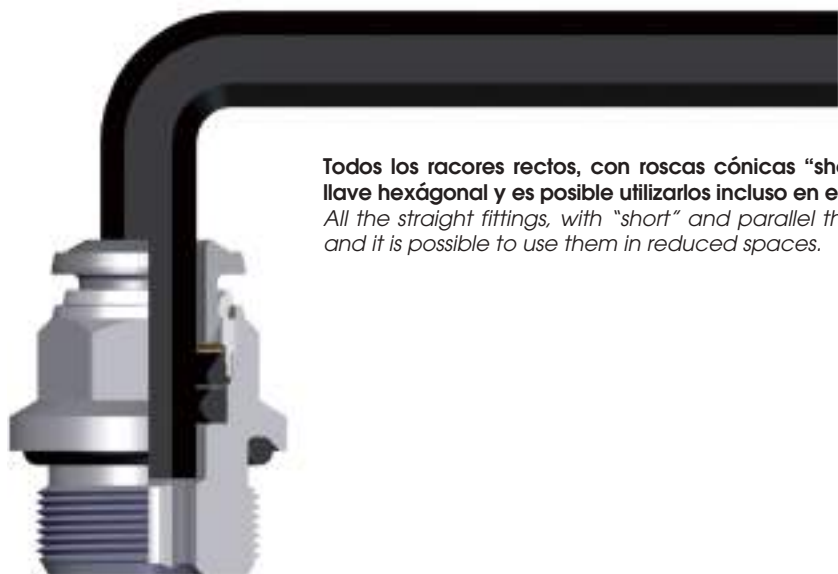

Todos los racores rectos, con roscas cónicas "short" o cilíndricas, pueden montarse también con llave hexágona y es posible utilizarlos incluso en espacios muy reducidos.

All the straight fittings, with "short" and parallel threads can be assembled also with Allen wrench and it is possible to use them in reduced spaces.

Pinza de sujeción / Clamping washer

La pinza en acero inox garantiza el perfecto agarre del tubo de cualquier material sin perjudicar la superficie.

The washer is made in stainless steel ensures the perfect tube clamping with every Kinds of materials without damage the surface.

La conexión entre tubo y racor asegura una estanqueidad total aun en condiciones de impacto o vibración.

The connection between the tube and the fitting ensure a total tightness even in severe conditions such as impact and vibrations.

La particular geometría de la junta garantiza una perfecta estanqueidad incluso en vacío.

The particular geometric shape of the seal ensure the perfect tightness even with vacuum.

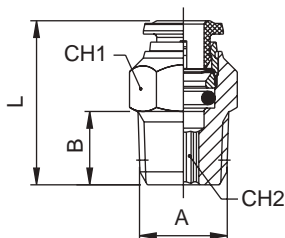

60000

RACOR RECTO MACHO CÓNICO - STRAIGHT MALE ADAPTOR (TAPER)

Código Code	Tubo Tube	A	B	L	CH1	CH2	Conf. Pack.
600000001	4	1/8	7.5	19	10	3	10
600000002	4	1/4	11	23	14	3	10
600000003	6	1/8	7.5	22.5	13	4	10
600000004	6	1/4	11	24.5	14	4	10
600000005	8	1/8	7.5	25.5	14	5	10
600000006	8	1/4	11	25	14	6	10
600000007	10	1/4	11	30.5	17	7	10
600000008	10	3/8	11.5	28	17	8	10
600000009	12	3/8	11.5	33.5	21	9	10
600000010	12	1/2	14	32	22	10	10

60020

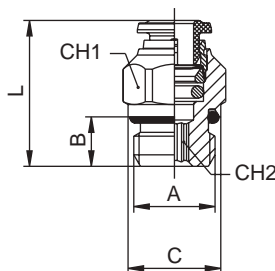
RACOR RECTO MACHO CILÍNDRICO CON TÓRICA (FKM) - STRAIGHT MALE ADAPTOR (PARALLEL)

Código Code	Tubo Tube	A	B	C	L	CH1	CH2	Conf. Pack.
600200011	4	M5	4	8	20	10	2	10
600200001	4	1/8	6	13	19.5	10	3	10
600200002	4	1/4	8	15	19.5	15	3	10
600200003	6	1/8	6	13	23.5	13	4	10
600200004	6	1/4	8	15	23.5	15	4	10
600200005	8	1/8	6	13	25.5	14	5	10
600200006	8	1/4	8	15	23.5	15	6	10
600200007	10	1/4	8	16	30	17	8	10
600200008	10	3/8	9	20	27	17	8	10
600200009	12	3/8	9	21	34	21	8	10
600200010	12	1/2	10	25	31	22	10	10

60040

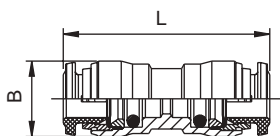
RACOR RECTO INTERMEDIO - STRAIGHT CONNECTOR

Código Code	Tubo Tube	L	B	Conf. Pack.
600400001	4	31	10.5	10
600400002	6	35	12.5	10
600400003	8	36.5	14.5	10
600400004	10	42	17.5	10
600400005	12	48	20.5	10

60050

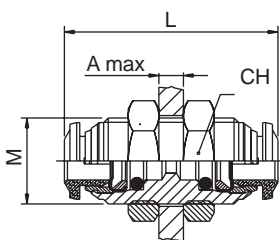
RACOR RECTO INTERMEDIO PASATABIQUES - BULKHEAD CONNECTOR

Código Code	Tubo Tube	M	L	CH	A max	Conf. Pack.
600500001	4	M12x1	31	17	7	10
600500002	6	M14x1	35	17	9.5	10
600500003	8	M16x1	37	19	10.5	10
600500004	10	M20x1	42	24	12.5	10
600500005	12	M22x1	48	26	16.5	10

60110

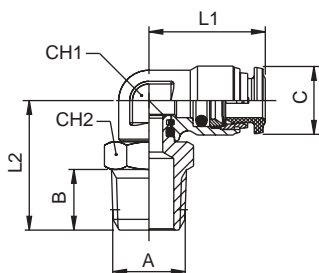
RACOR A L ORIENTABLE MACHO CÓNICO - SWIVEL ELBOW MALE ADAPTOR (TAPER)

Código Code	Tubo Tube	A	B	C	L1	L2	CH1	CH2	Conf. Pack.
601100001	4	1/8	7.5	10	18	17.5	9	11	10
601100002	4	1/4	11	10	18	21.5	9	14	10
601100003	6	1/8	7.5	12.5	21	19.5	11	11	10
601100004	6	1/4	11	12.5	21	23.5	11	14	10
601100005	8	1/8	7.5	14.5	22.5	20	12	11	10
601100006	8	1/4	11	14.5	22.5	24	12	14	10
601100007	10	1/4	11	17.5	26	25.5	16	17	10
601100008	10	3/8	11.5	17.5	26	27	16	17	10
601100009	10	1/2	14	17.5	26	30.5	16	22	10
601100010	12	3/8	11.5	20.5	30.5	30.5	19	18	10
601100011	12	1/2	14	20.5	30.5	33	19	22	10

60115

RACOR A L ORIENTABLE MACHO CILÍNDRICO CON TÓRICA (FKM) - SWIVEL ELBOW MALE ADAPTOR (PARALLEL)

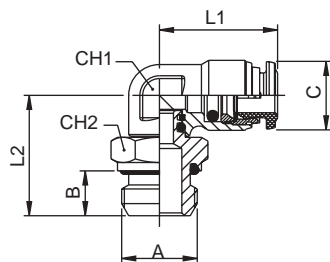

Código Code	Tubo Tube	A	B	L	CH1	CH2	Conf. Pack.		
6011500012	4	M5	4	10	18	15	9	8	10
6011500001	4	1/8	6	10	18	17	9	13	10
6011500002	4	1/4	8	10	18	19.5	9	15	10
6011500003	6	1/8	6	12.5	21	19	11	13	10
6011500004	6	1/4	8	12.5	21	21.5	11	15	10
6011500005	8	1/8	6	14.5	22.5	19.5	12	13	10
6011500006	8	1/4	8	14.5	22.5	21.5	12	15	10
6011500007	10	1/4	8	17.5	26	23	16	15	10
6011500008	10	3/8	9	17.5	26	26.5	16	21	10
6011500009	10	1/2	10	17.5	26	29	16	22	10
6011500010	12	3/8	9	20.5	30.5	29	19	21	10
6011500011	12	1/2	10	20.5	30.5	31.5	19	22	10

60130

RACOR A L INTERMEDIO - ELBOW CONNECTOR

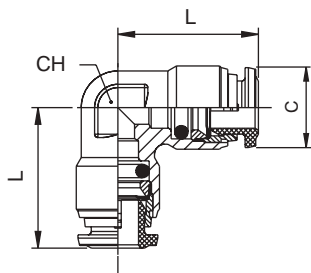

Código Code	Tubo Tube	C	L	CH	Conf. Pack.
6013000001	4	10	18	9	10
6013000002	6	12.5	21	11	10
6013000003	8	14.5	22.5	12	10
6013000004	10	17.5	26	16	10
6013000005	12	20.5	30.5	19	10

60210

RACOR A T ORIENTABLE MACHO CENTRAL CÓNICO - SWIVEL TEE MALE ADAPTOR (TAPER)-CENTRE LEG

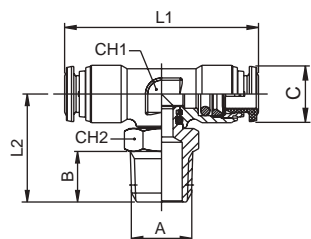

Código Code	Tubo Tube	A	B	C	L1	L2	CH1	CH2	Conf. Pack.
6021000001	4	1/8	7.5	10	36	18.5	9	11	10
6021000002	4	1/4	11	10	36	22.5	9	14	10
6021000003	6	1/8	7.5	12.5	42	19.5	11	11	10
6021000004	6	1/4	11	12.5	42	23.5	11	14	10
6021000005	8	1/8	7.5	14.5	45	20.5	12	11	10
6021000006	8	1/4	11	14.5	45	24.5	12	14	10
6021000007	10	1/4	11	17.5	52	26	16	14	10
6021000008	10	3/8	11.5	17.5	52	27.5	16	17	10
6021000009	10	1/2	14	17.5	52	31	16	22	10
6021000010	12	3/8	11.5	20.5	61	30.5	19	18	10
6021000011	12	1/2	14	20.5	61	33	19	22	10

60215

RACOR A T ORIENTABLE MACHO CENTRAL CILÍNDRICO CON TÓRICA (FKM) - SWIVEL TEE MALE ADAPTOR (PARALLEL)-CENTRE LEG

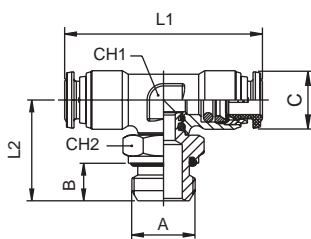

Código Code	Tubo Tube	A	B	C	L1	L2	CH1	CH2	Conf. Pack.
6021500012	4	M5	4	10	36	15	9	8	10
6021500001	4	1/8	6	10	36	18	9	13	10
6021500002	4	1/4	8	10	36	20.5	9	15	10
6021500003	6	1/8	6	12.5	42	19	11	13	10
6021500004	6	1/4	8	12.5	42	21.5	11	15	10
6021500005	8	1/8	6	14.5	45	20	12	13	10
6021500006	8	1/4	8	14.5	45	22	12	15	10
6021500007	10	1/4	8	17.5	52	23.5	16	15	10
6021500008	10	3/8	9	17.5	52	27	16	21	10
6021500009	10	1/2	10	17.5	52	29.5	16	22	10
6021500010	12	3/8	9	20.5	61	29	19	21	10
6021500011	12	1/2	10	20.5	61	31.5	19	22	10

60230

RACOR A T INTERMEDIO - TEE CONNECTOR

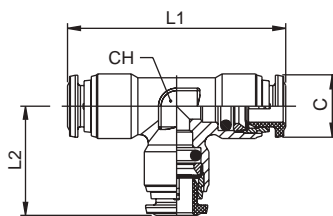

Código Code	Tubo Tube	C	L1	L2	CH	Conf. Pack.
6023000001	4	10	36	18	9	10
6023000002	6	12.5	42	21	11	10
6023000003	8	14.5	45	22.5	12	10
6023000004	10	17.5	52	26	16	10
6023000005	12	20.5	61	30.5	19	10

RACORDAJE RÁPIDO EN ACERO INOX

STAINLESS STEEL PUSH-ON FITTINGS

SERIE 61000

Características Técnicas / Technical Characteristics

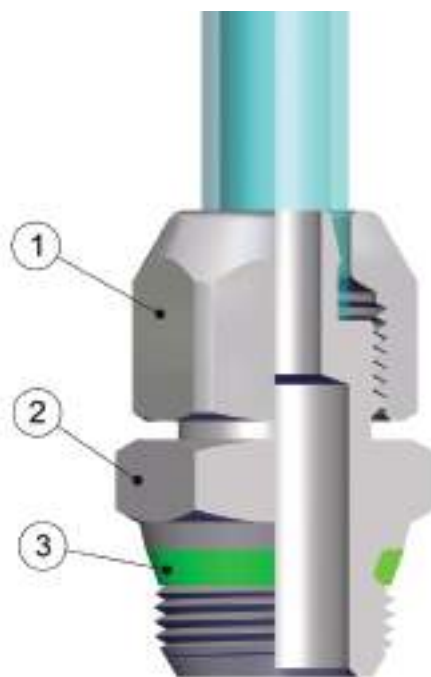

Materiales y Componentes / Component Parts and Materials

1 Tuerca en Acero inox aisi 316L	1 Aisi 316L Steel Nut
2 Cuerpo en Acero inox aisi 316L	2 Aisi 316L Steel Body
3 Junta en FKM alimentaria	3 Food FKM seal

Presiones / Pressures

Presión y temperatura son determinadas en función del tubo empleado, por tanto estos valores se definen en base a las características del mismo tubo.

The working pressures and working temperatures depend on wich type of tube used, for this reason, the values must be determined in accordance with the tube's features.

Presiones de Ejercicio / Working Pressures

Presión mínima / Minimum pressure: **-0.99 bar (-0.099 MPa)**
 Presión máxima / Maximum pressure: **15 bar (1.5 MPa)**

Temperaturas / Temperatures

Temperatura mínima / Minimum temperature: **-15 °C**
 Temperatura máxima / Maximum temperature: **+225 °C**

Roscas / Threads

Gas cónica conforme ISO 7.1, BS 21, DIN 2999 / Tapered gas in conformity with ISO7.1, BS 21, DIN 2999.

Gas cilíndrica conforme ISO 228 Clase A / Parallel gas in conformity with ISO 228 Class A.

Gas cónica "short" / "Short" tapered thread.

Tubos de conexión / Connection Tubes

Tubos en general.
 PA6, PA11, PA12, Polietileno, Poliuretano, PTFE, FEP.

Tube in general.
 PA6, PA11, PA12, Polyethylene, Polyurethane, PTFE, FEP.

Fluidos compatibles / Fluids

Aire comprimido - Vacío - Agua.
 Fluidos para la Industria alimentaria y química compatibles con los componentes del racor.
 Compressed air - Vacuum - Water.
 Fluid for food and chemical industry compatible with fitting components.

Roscas / Threads

La rosca cónica "short" ha sido proyectada para satisfacer las siguientes características:

- reducir la longitud
- reducir la llave respecto a algunos racores con rosca cilíndrica
- consentir el acoplamiento con diferentes standard de roscas hembra sean cónicas o cilíndricas

The "short" taper thread has been designed to offer the following advantages to the users:

- reduced overall length;
- smaller hex dimensions compared to the parallel threads;
- to allow the assembly with different female threads both taper as well as parallel;



consentir una completa estanqueidad incluso en superficies no perfectamente planas, cóncavas, convexas o inclinadas, con diferentes ángulos o radios.

To ensure the right tightening also with surfaces not perfectly flat, without spot-facing, concave convex and with different kinds of chamfers or radius.



Inclinada
Inclined



Cóncava
Concave



Convexa
Convex

61005

RACOR RECTO MACHO SHORT - STRAIGHT MALE ADAPTOR (SHORT)

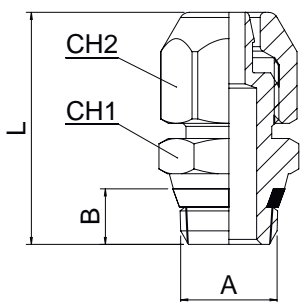

Código Code	Tubo Tube	A	B	L	CH1	CH2	Conf. Pack.
6100500003	6/4	1/8	5.5	23	12	12	10
6100500004	6/4	1/4	7	25.5	15	12	10
6100500006	8/6	1/8	5.5	23	12	14	10
6100500007	8/6	1/4	7	25.5	15	14	10
6100500011	10/8	1/4	7	27.5	15	16	10
6100500012	10/8	3/8	7.5	29	17	16	10

61040

RACOR RECTO INTERMEDIO - STRAIGHT CONNECTOR

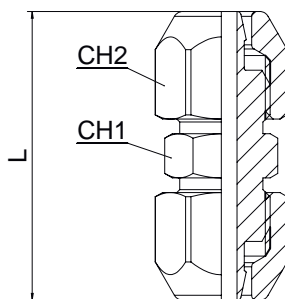

Código Code	Tubo Tube	L	CH1	CH2	Conf. Pack.
6104000004	6/4	29.5	10	12	10
6104000006	8/6	30	12	14	10
6104000009	10/8	34.5	14	16	10

61050

RACOR RECTO INTERMEDIO PASATABIQUES - BULKHEAD CONNECTOR

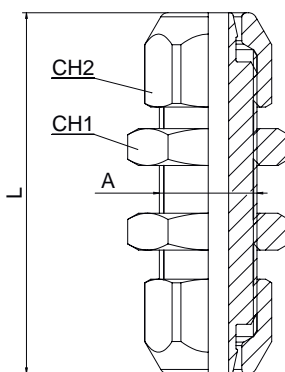

Código Code	Tubo Tube	A	L	CH1	CH2	Conf. Pack.
6105000004	6/4	M10x1	44	14	12	10
6105000006	8/6	M12x1	44	17	14	10

61100

RACOR A L MACHO CÓNICO - SWIVEL ELBOW MALE ADAPTOR (TAPER)

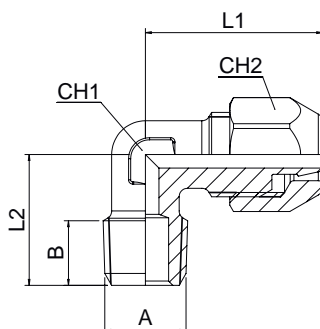

Código Code	Tubo Tube	A	B	L1	L2	CH1	CH2	Conf. Pack.
6110000003	6/4	1/8	7.5	21	15.5	8	12	10
6110000004	6/4	1/4	11	21	19.5	8	12	10
6110000006	8/6	1/8	7.5	22.5	17	10	14	10
6110000007	8/6	1/4	11	22.5	21	10	14	10
6110000011	10/8	1/4	11	25.5	21.5	12	16	10
6110000012	10/8	3/8	11.5	25.5	22	12	16	10

61130

RACOR A L INTERMEDIO - ELBOW CONNECTOR

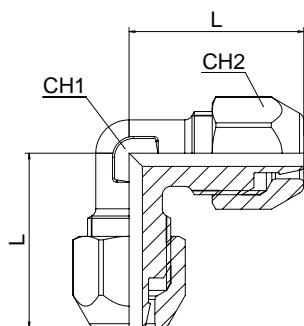

Código Code	Tubo Tube	L	CH1	CH2	Conf. Pack.
6113000003	6/4	21	8	12	10
6113000005	8/6	22.5	10	14	10
6113000006	10/8	25.5	12	16	10

61200

RACOR A T MACHO CÓNICO - SWIVEL TEE MALE ADAPTOR (TAPER)-CENTRE LEG

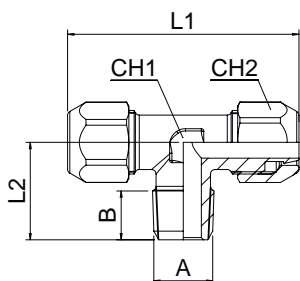

Código Code	Tubo Tube	A	B	L1	L2	CH1	CH2	Conf. Pack.
6120000003	6/4	1/8	7.5	42	15.5	8	12	10
6120000004	6/4	1/4	11	42	19.5	8	12	10
6120000005	8/6	1/8	7.5	45	17	10	14	10
6120000006	8/6	1/4	11	45	21	10	14	10
6120000008	10/8	1/4	11	51	21.5	12	16	10
6120000009	10/8	3/8	11.5	51	22	12	16	10

61230

RACOR A T INTERMEDIO - TEE CONNECTOR

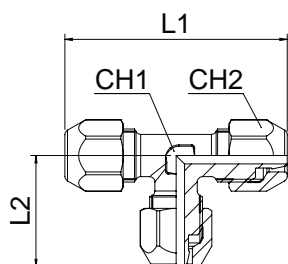

Código Code	Tubo Tube	L1	L2	CH1	CH2	Conf. Pack.
6123000003	6/4	42	21	8	12	10
6123000005	8/6	45	22.5	10	14	10
6123000008	10/8	51	25.5	12	16	10

61700

TUERCA - NUT

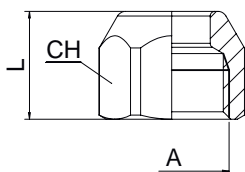

Código Code	Tubo Tube	A	L	CH	Conf. Pack.
6170000440X00	6/4	M10x1	11	12	10
6170000444X00	8/6	M12x1	11.5	14	10
6170000445X00	10/8	M14x1	13.5	16	10

ACCESORIOS DE ACERO INOXIDABLE STAINLESS STEEL ACCESSORIES

SERIE 62000

Características técnicas de los Accesorios / Accessories Technical Characteristics

Presiones / Pressures

Presión mínima / Minimum pressure: **-0.99 bar (-0.099 MPa)**

Presión máxima / Maximum pressure: **140 bar (14 MPa)**

Estas presiones son válidas para los accesorios sin junta tórica; **Para los accesorios con junta tórica consultar los valores de presión en la tabla del artículo.**

These pressures apply to the equipment without o-ring; For accessories with o-ring see pressure values directly from the table the article.

Temperaturas / Temperatures

Temperatura mínima / Minimum temperature: **-20 °C**

Temperatura máxima / Maximum temperature: **+225 °C**

Estas temperaturas son válidas para los accesorios sin junta tórica; **Para los accesorios con junta tórica consultar los valores de temperatura en la tabla del artículo.**

These temperatures apply to the equipment without o-ring; For accessories with o-ring see temperature values directly from the table the article.

Roscas / Threads

Gas cónica conforme ISO 7.1, BS 21, DIN 2999 / Tapered gas in conformity with ISO7.1, BS 21, DIN 2999.

Gas cilíndrica conforme ISO 228 Clase A / Parallel gas in conformity with ISO 228 Class A.

Métrica conforme ISO R/262 / Metric in conformity with ISO R/262.

Tubos de conexión / Connection Tubes

Tubos y racordaje en general

Tube and fittings in general.

Fluidos compatibles / Fluids

Fluidos para la industria alimentaria y química compatibles con los componentes del racor / Fluid for alimentar and chemical industry compatible with fitting components.

62000

MACHÓN CÓNICO - NIPPLE (TAPER)

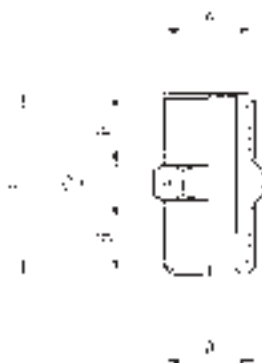

Código Code	A	B	L	CH	Conf. Pack.
620000440200	1/8	7.5	19.5	11	10
620000440300	1/4	11	27	14	10
620000440400	3/8	11.5	28	17	10
620000440500	1/2	14	33.5	22	10
620000440700	3/4	16.5	40	27	10

62020

MACHÓN CÓNICO DE REDUCCIÓN - REDUCING NIPPLE (TAPER)

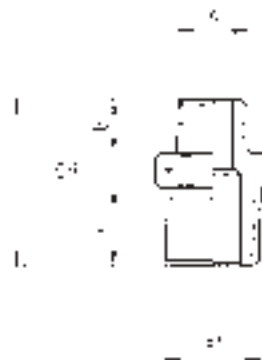

Código Code	A	A1	B	C	L	CH	Conf. Pack.
620200044AT00	1/8	1/4	7.5	11	23.5	14	10
6202000443W00	1/8	3/8	7.5	11.5	24	17	10
6202000447W00	1/4	3/8	11	11.5	27.5	17	10
6202000448W00	1/4	1/2	11	14	30.5	22	10
620200044AC00	3/8	1/2	11.5	14	31	22	10
620200044AH00	1/2	3/4	14	16.5	37.5	27	10

62040

UNIÓN CÓNICA MACHO-HEMBRA - REDUCER (TAPER)



Código Code	A	A1	B	L	CH	Conf. Pack.
620400044AT00	1/8	1/4	7.5	22	17	10
6204000447W00	1/4	3/8	11	27	22	10
6204000448W00	1/4	1/2	11	30	24	10
620400044AC00	3/8	1/2	11.5	30.5	24	10
620400044AH00	1/2	3/4	14	35	32	10

62080

REDUCCIÓN CÓNICA - REDUCER (TAPER)

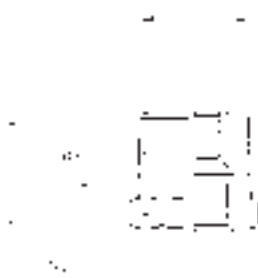

Código Code	A	A1	B	L	CH	Conf. Pack.
6208000445W00	1/4	1/8	11	16	14	10
6208000449W00	3/8	1/8	11.5	16.5	17	10
620800044AA00	3/8	1/4	11.5	16.5	17	10
620800044AE00	1/2	1/4	14	19.5	22	10
620800044AF00	1/2	3/8	14	19.5	22	10
620800044AM00	3/4	1/2	16.5	23.5	27	10

62300

MANGUITO HEMBRA - SLEEVE



Código Code	A	L	CH	Conf. Pack.
6230000440200	1/8	15	14	10
6230000440300	1/4	22	17	10
6230000440400	3/8	24	22	10
6230000440500	1/2	30	27	10
6230000440700	3/4	32	32	10

62310

MANGUITO HEMBRA DE REDUCCIÓN - REDUCING SLEEVE



Código Code	A	A1	L	CH	Conf. Pack.
623100044AT00	1/8	1/4	19	17	10
6231000447W00	1/4	3/8	23	22	10
623100044AC00	3/8	1/2	27.5	24	10
623100044AH00	1/2	3/4	30	30	10

62315

TAPÓN MACHO CILÍNDRICO HEXÁGONO INTERIOR CON TÓRICA (FKM) - MALE PLUG (PARALLEL) WITH EXAGON EMBEDDED



Código Code	A	B	L	D	CH	Conf. Pack.
6231500001	1/8	6	8.5	14	5	10
6231500002	1/4	8	11	18	6	10
6231500003	3/8	9	12.5	20	8	10
6231500004	1/2	10	13.5	25	10	10

Temperatura mínima / Minimum temperature: -15 °C
 Temperatura máxima / Maximum temperature: +225 °C
 Presión mínima / Minimum pressure: -0.99 bar (-0.099 MPa)
 Presión máxima / Maximum pressure: 15 bar (1.5 MPa)

62320

TAPÓN MACHO CILÍNDRICO - MALE PLUG (PARALLEL)

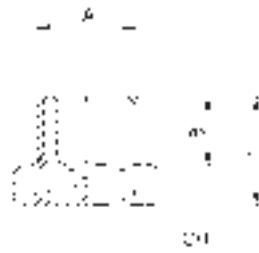

Código Code	A	B	L	CH	Conf. Pack.
6232000440200	1/8	6.5	10	14	10
6232000440300	1/4	9	13	17	10
6232000440400	3/8	9.5	13.5	19	10
6232000440500	1/2	10	14.5	24	10
6232000440700	3/4	11	16	30	10

62325

TAPÓN MACHO CÓNICO HEXÁGONO INTERIOR - MALE PLUG (TAPER)



Código Code	A	B	H	CH	Conf. Pack.
6232500440200	1/8	7.5	5	5	10
6232500440300	1/4	10	7	6	10
6232500440400	3/8	11	7	8	10
6232500440500	1/2	13	8	10	10

62340

ESPIGA MACHO CÓNICA - MALE HOSE ADAPTER (TAPER)



Código Code	A	A1	B	C	L	CH	Conf. Pack.
623400044BS00	6	1/8	19.5	7.5	32	11	10
623400044BZ00	7	1/8	19.5	7.5	32	11	10
623400044BX00	7	1/4	19.5	11	35.5	14	10
623400044BJ00	8	1/4	19.5	11	35.5	14	10
623400044CB00	9	1/4	19.5	11	35.5	14	10
623400044CC00	9	3/8	19.5	11.5	36	17	10
623400044CF00	10	1/4	19.5	11	35.5	14	10
623400044CG00	10	3/8	19.5	11.5	36	17	10
623400044CH00	10	1/2	19.5	14	39	22	10
623400044CI00	12	1/4	19.5	11	35.5	14	10
623400044CL00	12	3/8	19.5	11.5	36	17	10
623400044CM00	12	1/2	19.5	14	39	22	10
623400044CN00	14	3/8	19.5	11.5	36	17	10
623400044DB00	14	1/2	19.5	14	39	22	10
623400044CR00	16	1/2	19.5	14	39	22	10
623400044CZ00	18	1/2	19.5	14	39	22	10
623400044CX00	18	3/4	19.5	16.5	43.5	27	10
623400044CJ00	20	1/2	19.5	14	39	22	10
623400044DH00	20	3/4	19.5	13.5	40	27	10

62400

RACOR A T HEMBRA - FEMALE TEE

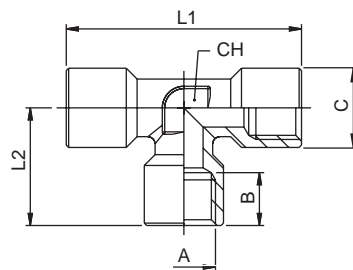

Código Code	A	B	C	L1	L2	CH	Conf. Pack.
6240000440200	1/8	8.5	18.5	37	18.5	12	10
6240000440300	1/4	11	24.5	49	24.5	12	10
6240000440400	3/8	12	27	54	27	15	10
6240000440500	1/2	15	32	64	32	20	10

62440

RACOR A T MACHO CENTRAL - CENTRE LEG MALE TEE

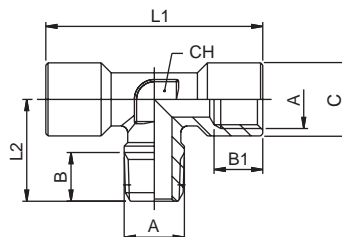

Código Code	A	B	B1	C	L1	L2	CH	Conf. Pack.
6244000440200	1/8	7.5	8.5	17.5	37	17.5	12	10
6244000440300	1/4	11	11	23	49	23	12	10
6244000440400	3/8	11.5	12	25.5	54	25.5	15	10
6244000440500	1/2	14	15	29.5	64	29.5	20	10

62450

RACOR A T MACHO LATERAL - OFF SET MALE TEE

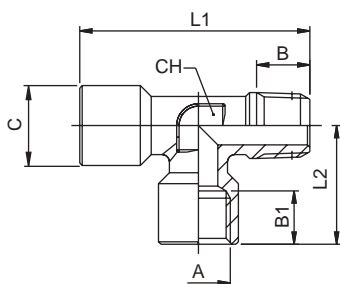

Código Code	A	B	B1	C	L1	L2	CH	Conf. Pack.
6245000440200	1/8	7.5	8.5	18.5	36	18.5	12	10
6245000440300	1/4	11	11	24.5	47.5	24.5	12	10
6245000440400	3/8	11.5	12	27	52.5	27	15	10
6245000440500	1/2	14	15	32	61.5	32	20	10

62510

RACOR A L HEMBRA - FEMALE ELBOW

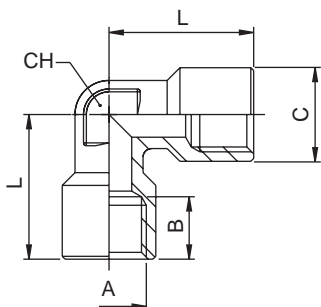

Código Code	A	C	B	L	CH	Conf. Pack.
6251000440200	1/8	13	8.5	21	10	10
6251000440300	1/4	16.5	11	25.5	12	10
6251000440400	3/8	20.5	12	28	15	10
6251000440500	1/2	25.5	15	32	20	10

62520

RACOR A L MACHO-HEMBRA - MALE FEMALE ELBOW

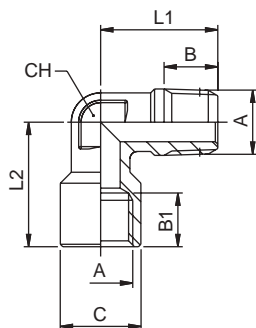

Código Code	A	B	B1	C	L1	L2	CH	Conf. Pack.
6252000440200	1/8	7.5	8.5	21	18	21	10	10
6252000440300	1/4	11	11	25.5	24	25.5	12	10
6252000440400	3/8	11.5	12	28	27	28	15	10
6252000440500	1/2	14	15	32	29.5	32	20	10

62540

SILENCIADOR - SILENCER



dB = Abatimiento acústico (dB) a 6 bar
Acoustic fading (dB) at 6 bar

CARACTERÍSTICAS TÉCNICAS / TECHNICAL CHARACTERISTICS

Presión máxima / maximum pressure:	10 bar
Temperatura mínima / minimum temperature:	-20°C
Temperatura máxima / maximum temperature:	+300°C
Grado de filtración / filtration threshold:	76 µm

Código Code	A	F	H	CH	dB	Conf. Pack.
6254000001	1/8	8	15	14	30.6	25
6254000002	1/4	8	15	17	33	25
6254000003	3/8	10	18	22	35	25
6254000004	1/2	12	22	27	23	25

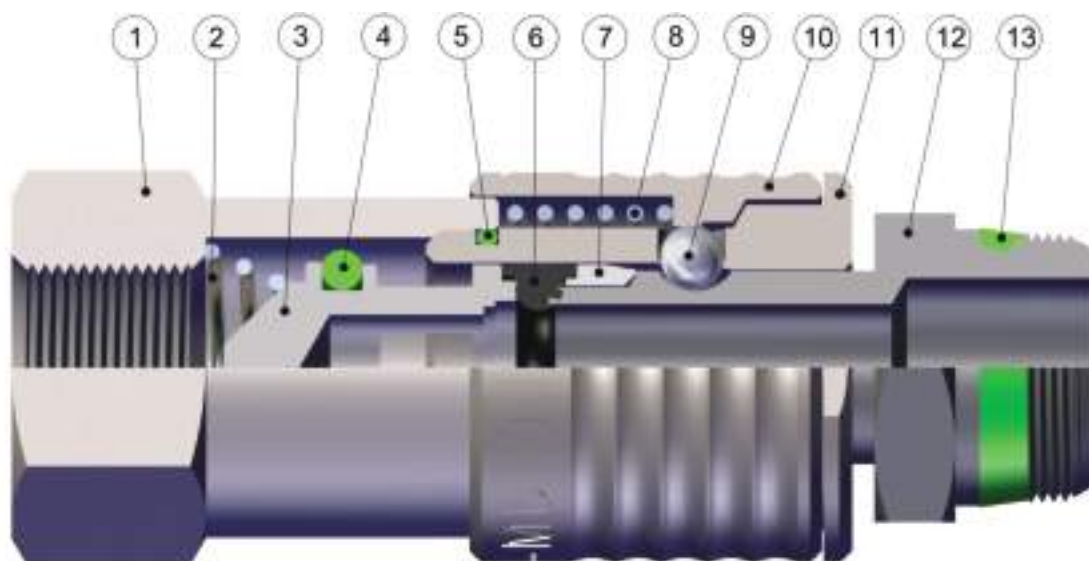
MULTIPRESA EN ACERO INOX
STAINLESS STEEL MULTISOCKET
SERIE 63000
Características Técnicas / Technical Characteristics

Materiales y Componentes / Component Parts and Materials

- | | |
|---|--|
| 1 Terminal de conexión en acero INOX AISI 316L | 1 AISI 316L Steel coupling back part |
| 2 Muelle obturador en acero INOX AISI 302 | 2 AISI 302 Steel shutter thrust spring |
| 3 Obturador en acero INOX AISI 316L | 3 AISI 316L Steel shutter |
| 4 Junta tórica Obturador en FKM alimentaria | 4 Food FKM shutter O-Ring seal |
| 5 Junta tórica cuerpo en FKM alimentaria | 5 Food FKM body O-Ring seal |
| 6 Junta adaptador en FKM alimentaria | 6 Food FKM plug seal |
| 7 Anillo guía adaptador en acero INOX AISI 316L | 7 AISI 316L Steel guide ring coupling |
| 8 Muelle tuerca en acero INOX AISI 302 | 8 AISI 302 Steel ring nut spring |
| 9 Esfera en acero INOX AISI 420 | 9 AISI 420 Steel ball |
| 10 Tuerca en acero INOX AISI 316L | 10 AISI 316L Steel sleeve |
| 11 Cuerpo en acero INOX AISI 316L | 11 AISI 316L Steel body |
| 12 Adaptador en acero INOX AISI 316L | 12 AISI 316L Steel plug outline |
| 13 Junta rosca en FKM alimentaria | 13 Food FKM thread packing |

Presiones / Pressures

Presión mínima / Minimum pressure: **0 bar (0 MPa)**
 Presión máxima / Maximum pressure: **16 bar (1.6 MPa)**

Temperaturas / Temperatures

Temperatura mínima / Minimum temperature: **-15 °C**
 Temperatura máxima / Maximum temperature: **+200 °C**

Roscas / Threads

Gas cilíndrica conforme ISO 228 Clase A / Parallel gas in conformity with ISO 228 Class A.
 Gas cónica "short" / "Short" tapered thread.

Tubos de conexión / Connection Tubes

Tubos en material plástico, lineales o espiralados. Tubos en goma.

Flexible tubes in plastic and rubber.

Fluidos compatibles / Fluids

Aire comprimido.
 Fluidos para la Industria alimentaria y química compatibles con los componentes del racor.
 Compressed air.
 Fluid for food and chemical industry compatible with fitting components.

63190

ENCHUFE MACHO SHORT - MALE SOCKET (SHORT)

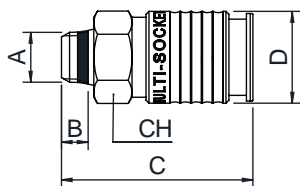

Código Code	A	B	C	D	CH	Conf. Pack.
631900002	1/4	7	50	24	21	2
631900003	3/8	7.5	50.5	24	21	2
631900004	1/2	9	52	24	21	2

63192

ENCHUFE HEMBRA - FEMALE SOCKET

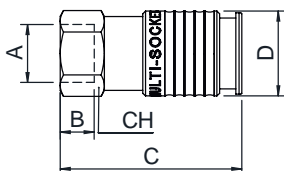

Código Code	A	B	C	D	CH	Conf. Pack.
631920002	1/4	11	51.5	24	21	2
631920003	3/8	11.5	52	24	21	2
631920004	1/2	15	56.5	24	24	2

63260

ADAPTADOR PERFIL EUROPEO MACHO SHORT - MALE PLUG EUROPEAN PROFILE (SHORT)

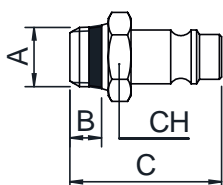

Código Code	A	B	C	D	CH	Conf. Pack.
632600002	1/4	7	33.5	-	17	2
632600003	3/8	7.5	34	-	19	2
632600004	1/2	9	36	-	24	2

63262

ADAPTADOR PERFIL EUROPEO HEMBRA - FEMALE PLUG EUROPEAN PROFILE

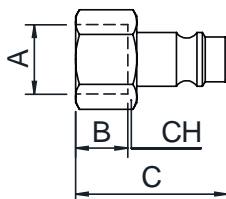

Código Code	A	B	C	D	CH	Conf. Pack.
6326200440300	1/4	11	33	-	17	2
6326200440400	3/8	11.5	33.5	-	19	2
6326200440500	1/2	15	37	-	24	2



89000

Serie 89000

**RACORDAJE AUTOMÁTICO CON ANILLO METÁLICO
PARA TUBO EN PULGADAS**
INCH TUBE PUSH-IN FITTINGS WITH METAL COLLET

Características Técnicas / Technical Characteristics

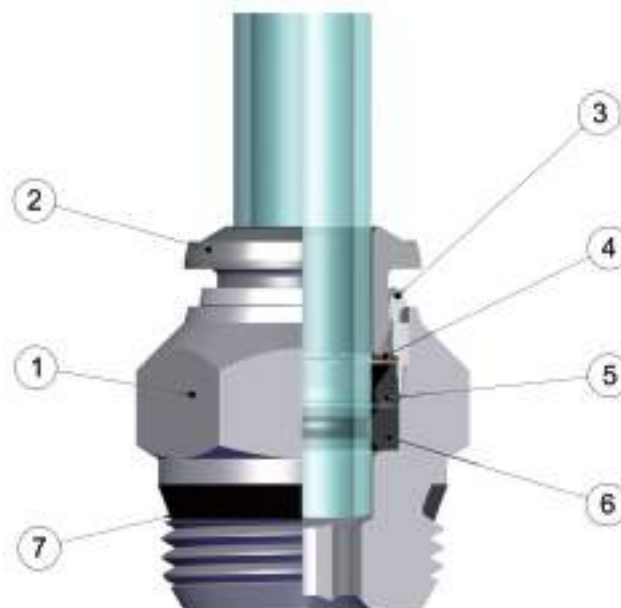

Materiales y Componentes / Component Parts and Materials

- 1 Cuerpo en latón niquelado
- 2 Anillo extractor tubo en latón niquelado
- 3 Cápsula en latón niquelado
- 4 Pinza de agarre en acero inox aisi 301
- 5 Anillo de seguridad en Tecnopolímero
- 6 Junta de labio en NBR
- 7 Junta rosca en NBR

- 1 Nickel-plated brass Body
- 2 Nickel-plated brass Collet
- 3 Nickel-plated brass Capsule
- 4 Steel aisi 301 Clamping washer
- 5 Technopolymeric Safety ring
- 6 Nbr Lip seal
- 7 Nbr Thread packing

Presiones / Pressures

Presión mínima / Minimum pressure: **-0.99 bar** (-0.099 MPa)
 Presión máxima / Maximum pressure: **15 bar** (1.5 MPa)

Temperaturas / Temperatures

Temperatura mínima / Minimum temperature: **-20 °C**
 Temperatura máxima / Maximum temperature: **+80 °C**

Roscas / Threads

Rosca cónica "short" / "Short" taper thread.

Gas cónica conforme ISO 7.1, BS 21, DIN 2999 / Tapered gas in conformity with ISO 7.1, BS 21, DIN 2999.

Gas cilíndrica conforme ISO 228 Clase A / Parallel gas in conformity with ISO 228 Class A.

Tubos de conexión / Connection Tubes

Tubos en material plástico:

PA6, PA11, PA12, Polietileno, *Poliuretano; etc.

*Para tubos en Poliuretano es aconsejada una dureza de 98 shore.

Plastic tubes:

PA6, PA11, PA12, Polyethylene, *Polyurethane, ecc.

*For Polyurethane hoses it is required a minimum hardness of 98 shore.

Fluidos compatibles / Fluids

Aire comprimido / Compressed air.

Vacío / Vacuum

Agua / Water

Roscas / Threads

La rosca cónica "short" ha sido proyectada para satisfacer las siguientes características:

- reducir la longitud
- reducir la llave respecto a algunos racores con rosca cilíndrica
- consentir el acoplamiento con diferentes standard de roscas hembra sean cónicas o cilíndricas

The "short" taper thread has been designed to offer the following advantages to the users:

- reduced overall length;
- smaller hex dimensions compared to the parallel threads;
- to allow the assembly with different female threads both taper as well as parallel;



consentir una completa estanqueidad incluso en superficies no perfectamente planas, cóncavas, convexas o inclinadas, con diferentes ángulos o radios.

To ensure the right tightening also with surfaces not perfectly flat, without spot-facing, concave convex and with different kinds of chamfers or radius.



Inclinada
Inclined



Cóncava
Concave



Convexa
Convex

Par de apriete / Torque specifications



PAR DE APRIETE PARA ROSCAS MACHO UNF
TORQUE TO MALE THREADS UNF

MEDIDA MEASURE	PAR ACONSEJADO Nm RECOMMENDED TORQUE Nm	PAR DE ROTURA Nm BREAKING TORQUE Nm
10/32	0,08	0,32

LOS VALORES DE ROTURA PUEDEN VARIAR EN FUNCIÓN DEL ARTÍCULO
BREAKING VALUES MAY VARY ACCORDING TO THE ITEM



PAR DE APRIETE PARA ROSCAS MACHO "SHORT"
TORQUE TO MALE THREADS "SHORT"

MEDIDA MEASURE	PAR MÍNIMO ACONSEJADO Nm RECOMMENDED MINIMUM TORQUE Nm	PAR MÁXIMO ACONSEJADO Nm RECOMMENDED MAX TORQUE Nm
1/8	5	7
1/4	5	7
3/8	5	7
1/2	5	7

LOS VALORES DE ROTURA PUEDEN VARIAR EN FUNCIÓN DEL ARTÍCULO
BREAKING VALUES MAY VARY ACCORDING TO THE ITEM

Roscas / Threads

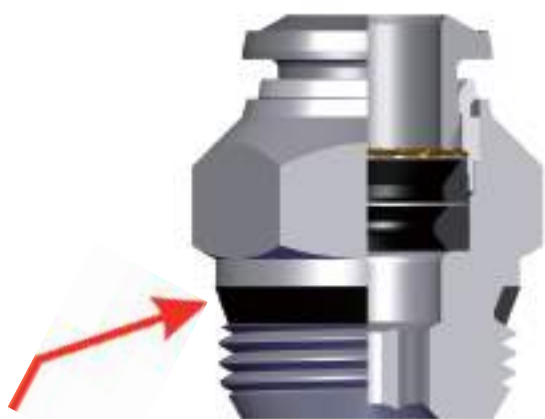

Junta de cierre para roscas cónicas "short".
Thread packing for the "short" taper threads.

Todas las roscas de esta serie (incluyendo la medida de M5) están fabricadas con junta de cierre que permite la inmediata utilización del racor reduciendo notablemente el tiempo de instalación.

All of threads from this range (also the M5), have been equipped with tightening parts which allow the direct assembly of the fittings, reducing the installation time.



Todos los racores rectos, con roscas "short" o cilíndricas, pueden montarse también con llave hexágona y es posible utilizarlos incluso en espacios muy reducidos.

All the straight fittings, with "short" and parallel threads can be assembled also with Allen wrench and it is possible to use them in reduced spaces.

Pinza de sujeción / Clamping washer

La pinza en acero inox garantiza el perfecto agarre del tubo de cualquier material sin perjudicar la superficie.

The washer is made in stainless steel ensures the perfect tube clamping with every kinds of materials without damage the surface.

La conexión entre tubo y racor asegura una estanqueidad total aun en condiciones de impacto o vibración.

The connection between the tube and the fitting ensure a total tightness even in severe conditions such as impact and vibrations.

La particular geometría de la junta garantiza una perfecta estanqueidad incluso en vacío.

The particular geometric shape of the seal ensure the perfect tightness even with vacuum.

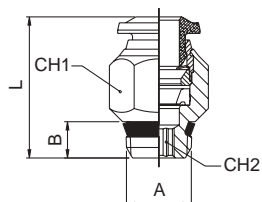

89000

RACOR RECTO MACHO SHORT - STRAIGHT MALE ADAPTOR (SHORT)

Código Code	Tubo Tube	A	B	L	CH1	CH2	Conf. Pack.
8900000001	1/8	1/8	5.5	16.5	11	2	10
8900000002	1/8	1/4	7	18.5	11	2	10
*8900000003	5/32 (4)	1/8	5.5	18	11	3	10
*8900000004	5/32 (4)	1/4	7	19	14	3	10
8900000005	1/4	1/8	6.5	21.5	13	4	10
8900000006	1/4	1/4	7	20.5	14	4	10
8900000007	1/4	3/8	7.5	23	17	4	10
*8900000008	5/16 (8)	1/8	5.5	24.5	14	5	10
*8900000009	5/16 (8)	1/4	7	22	14	6	10
*8900000010	5/16 (8)	3/8	7.5	23	17	6	10
8900000011	3/8	1/8	5.5	27.5	17	6	10
8900000012	3/8	1/4	7	27.5	17	5	10
8900000013	3/8	3/8	7.5	25.5	17	7	10
8900000014	3/8	1/2	9	25.5	21	7	10
8900000015	1/2	1/8	5.5	32	20	5	10
8900000016	1/2	1/4	7	31	20	7	10
8900000017	1/2	3/8	7.5	31	20	9	10
8900000018	1/2	1/2	9	31	21	10	10
8900000019	1/8	10/32	5	19	8	2	10
8900000020	5/32	10/32	5	21	10	2	10
8900000021	1/4	10/32	5	24.5	13	2	10
*8900000022	5/16 (8)	1/2	9	23.5	21	6	10

** Artículos en común con la serie 57000 para tubos métricos*
** Items in common with series 57000 for metric tubes*

89010

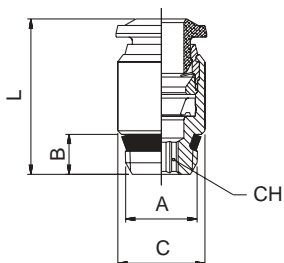
RACOR RECTO MACHO SHORT HEXÁGONO INTERIOR - STRAIGHT MALE ADAPTOR (SHORT) WITH EXAGON EMBEDDED

Código Code	Tubo Tube	A	B	C	L	CH	Conf. Pack.
*8901000001	5/32 (4)	1/8	7.5	10	19	3	10
*8901000002	5/16 (8)	1/8	7.5	14	25.5	5	10
*8901000003	5/16 (8)	1/4	11	14	25	6	10

** Artículos en común con la serie 57000 para tubos métricos*
** Items in common with series 57000 for metric tubes*

89030

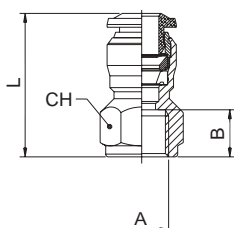
RACOR RECTO HEMBRA (NPTF) - STRAIGHT FEMALE ADAPTOR (NPTF)

Código Code	Tubo Tube	A - NPTF	B	L	CH	Conf. Pack.
8903000001	1/8	1/8	9.5	24	13	10
8903000002	1/8	1/4	13.5	29	16	10
8903000003	5/32	1/8	9.5	24.5	13	10
8903000004	5/32	1/4	13.5	29.5	16	10
8903000005	1/4	1/8	9.5	26	13	10
8903000006	1/4	1/4	13.5	31	16	10
8903000007	3/8	1/4	13.5	34.5	18	10
8903000008	3/8	3/8	13.5	34.5	20	10

89040

RACOR RECTO INTERMEDIO - STRAIGHT CONNECTOR

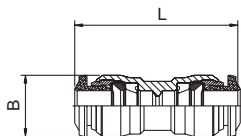

Código Code	Tubo Tube	Tubo Tube	L	B	Conf. Pack.
890400001	1/8		8.5	26	10
*570400001	5/32 (4)		10.5	30.5	10
890400003	1/4	5/32	12.5	33	10
890400004	1/4		12.5	34	10
*570400008	3/16 (5)		33	11.5	10
*570400005	5/16 (8)		14.5	36	10
890400006	3/8	1/4	17.5	41	10
890400009	3/8	1/2	20.5	41	10
890400007	3/8		17.5	41	10
890400008	1/2		20.5	47	10

*Artículos en común con la serie 57000 para tubos métricos
*Items in common with series 57000 for metric tubes

89050

RACOR RECTO INTERMEDIO PASATABIQUES - BULKHEAD CONNECTOR

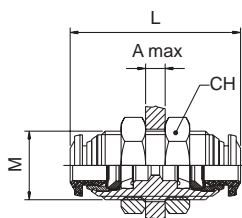

Código Code	Tubo Tube	M	L	CH	A max	Conf. Pack.
890500001	1/8	M10x1	26	14	5	10
*570500001	5/32 (4)	M12x1	31.5	17	7	10
890500003	1/4	M14x1	35	17	9.5	10
*570500003	5/16 (8)	M16x1	37	19	10.5	10
890500005	3/8	M20x1	42	24	12.5	10
890500006	1/2	M22x1	48	26	16.5	10

*Artículos en común con la serie 57000 para tubos métricos
*Items in common with series 57000 for metric tubes

89106

RACOR A L HEMBRA ORIENTABLE (NPTF) - ORIENTING ELBOW FEMALE ADAPTOR (NPTF)

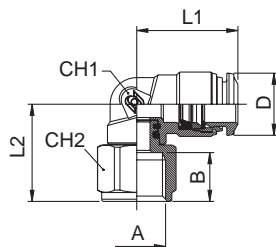

Código Code	Tubo Tube	A - NPTF	B	L1	L2	CH1	CH2	D	Conf. Pack.
891060001	5/32	1/8	9.5	17.5	17.5	9	13	10	10
891060002	5/32	1/4	13.5	17.5	20	9	16	10	10
891060003	1/4	1/8	9.5	21.5	19	11	13	12.5	10
891060004	1/4	1/4	13.5	21.5	21.5	11	16	12.5	10
891060005	3/8	1/8	9.5	27	23	13	13	17.5	10
891060006	3/8	1/4	13.5	27	24	16	16	17.5	10

89111

RACOR A L ORIENTABLE MACHO SHORT - ORIENTING ELBOW MALE ADAPTOR (SHORT)

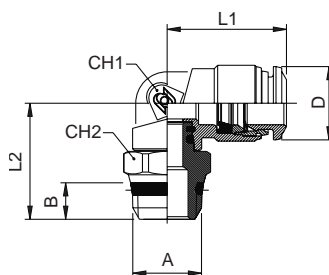

Código Code	Tubo Tube	A	B	L1	L2	CH	CH2	D	Conf. Pack.
891110001	1/8	1/8	7	18	9	9	13	10	10
891110002	1/8	1/4	8.5	18	19.6	9	15	10	10
*891110003	5/32 (4)	1/8	5.5	18	19.5	9	13	10	10
*891110004	5/32 (4)	1/4	7	18	21	9	15	10	10
891110005	1/4	1/8	7	22.5	19.7	11	13	12.5	10
891110006	1/4	1/4	8.5	22.5	19.7	11	15	12.5	10
891110007	1/4	3/8	9	22.5	19.7	11	17	12.5	10
*891110008	5/16 (8)	1/8	5.5	22.5	22.5	12	13	14.5	10
*891110009	5/16 (8)	1/4	7	22.5	22.5	12	15	14.5	10
*891110010	5/16 (8)	3/8	7.5	22.5	23	12	17	14.5	10
*891110018	5/16 (8)	1/2	9	22.5	25.5	12	21	14.5	10
8911100011	3/8	1/8	7	26.5	26	14	14	17.5	10
8911100012	3/8	1/4	8.5	26.7	26	14	17.5	17.5	10
8911100013	3/8	3/8	9	24.7	26	14	17.5	17.5	10
8911100014	3/8	1/2	8.5	26.7	26	17	15	17.5	10
8911100015	1/2	1/4	8.5	30.5	28.7	16	15	17.5	10
8911100016	1/2	3/8	7.5	31.5	26.5	16	20	21.5	10
8911100017	1/2	1/2	9	31.5	29	16	21	21.5	10

*Artículos en común con la serie 57000 para tubos métricos
*Items in common with series 57000 for metric tubes

89116

RACOR A L ORIENTABLE MACHO CILÍNDRICO - ORIENTING ELBOW MALE ADAPTOR (PARALLEL)

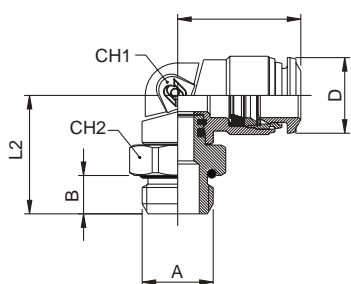

Código Code	Tubo Tube	A	B	L1	L2	CH1	CH2	D	Conf. Pack.
8911600001	1/8	10/32	5	18	20	9	8	10	10
8911600002	5/32	10/32	5	18	20	9	8	10	10
8911600003	1/4	10/32	5	21	22	11	8	12.5	10

89130

RACOR A L INTERMEDIO - ELBOW CONNECTOR

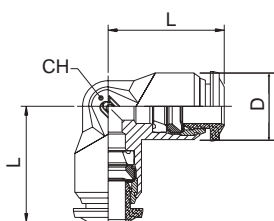

Código Code	Tubo Tube	L	CH	D	Conf. Pack.
*5713000001	5/32 (4)	17	9	10	10
8913000001	1/8	16.5	9	10	10
8913000003	1/4	21	11	12.5	10
*5713000003	(5/16) 8	22.5	13	14	10
8913000005	3/8	26	16	17.5	10
8913000006	1/2	30.5	19	21.5	10

*Artículos en común con la serie 57000 para tubos métricos
* Items in common with series 57000 for metric tubes

89211

RACOR A T ORIENTABLE MACHO SHORT - ORIENTING TEE MALE ADAPTOR (SHORT) - CENTRE LEG

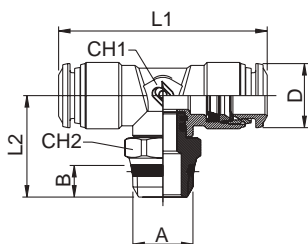

Código Code	Tubo Tube	A	B	L1	L2	CH1	CH2	D	Conf. Pack.
*8921100016	5/16 (8) 1/8	5.5	45	25.5	13	13	14.5	10	
*8921100015	5/16 (8) 1/4	7	45	25.5	13	15	14.5	10	
*8921100017	5/16 (8) 3/8	7.5	45	26	13	17	14.5	10	
8921100001	1/8 1/8	5.5	34	17	9	8	10	10	
8921100002	1/8 1/4	7	34	20	9	15	10	10	
*8921100003	5/32 (4) 1/8	5.5	34	20	9	13	10	10	
*8921100004	5/32 (4) 1/4	7	34	21.5	9	15	10	10	
8921100005	1/4 1/8	5.5	40	20	11	13	12.5	10	
8921100006	1/4 1/4	7	40	21.5	11	16	12.5	10	
8921100007	1/4 3/8	7.5	40	22	11	17	12.5	10	
8921100014	3/8 1/8	5.5	52	26.5	14	14	17.5	10	
8921100008	3/8 1/4	7	52	29	14	16	17.5	10	
8921100009	3/8 3/8	7.5	52	27	14	17	17.5	10	
8921100010	3/8 1/2	9	52	31	14	21	17.5	10	
8921100011	1/2 1/4	7	61	31.5	16	15	21.5	10	
8921100012	1/2 3/8	7.5	61	29.5	16	17	21.5	10	
8921100013	1/2 1/2	9	61	32	16	21	21.5	10	

*Artículos en común con la serie 57000 para tubos métricos
* Items in common with series 57000 for metric tubes

89216

RACOR A T ORIENTABLE MACHO CILÍNDRICO - ORIENTING TEE MALE ADAPTOR (PARALLEL) CENTRE LEG

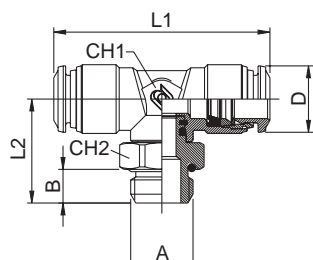

Código Code	Tubo Tube	A	B	L1	L2	CH1	CH2	D	Conf. Pack.
8921600001	1/8	10/32	3.5	33	17	9	8	10	10
8921600002	5/32	10/32	3.5	34	18	9	8	10	10
8921600003	1/4	10/32	3.5	42	20.5	11	11	12.5	10

89223

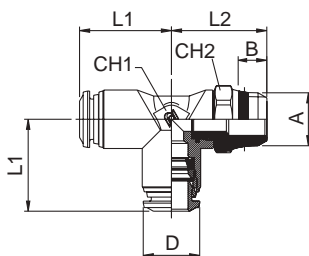
RACOR A T ORIENTABLE MACHO LATERAL SHORT - ORIENTING TEE MALE ADAPTOR (SHORT) OFF - SET LEG

Código Code	Tubo Tube	A	B	L1	L2	CH1	CH2	D	Conf. Pack.
*8922300015	5/16 (8)	1/8	5.5	22.5	24	13	13	14.5	10
*8922300016	5/16 (8)	1/4	7	22.5	24	13	15	14.5	10
*8922300017	5/16 (8)	3/8	7.5	22.5	27	13	17	14.5	10
8922300001	1/8	1/8	5.5	16.5	18.5	9	13	10	10
8922300002	1/8	1/4	7	16.5	20.5	9	15	10	10
*8922300003	5/32 (4)	1/8	5.5	17	20	9	13	10	10
*8922300004	5/32 (4)	1/4	7	17	21.5	9	15	10	10
8922300005	1/4	1/8	5.5	21.5	20	11	13	12.5	10
8922300006	1/4	1/4	7	21.5	21.5	11	15	12.5	10
8922300007	1/4	3/8	7.5	21.5	22	11	17	12.5	10
8922300014	3/8	1/8	7	27	26	14	14	17.5	10
8922300008	3/8	1/4	7	27	26.5	14	16	17.5	10
8922300009	3/8	3/8	7.5	27	27	14	17	17.5	10
8922300010	3/8	1/2	9	27	29	14	21	17.5	10
8922300011	1/2	1/4	7	31.5	31.5	16	15	21.5	10
8922300012	1/2	3/8	7.5	31.5	31.5	16	15	21.5	10
8922300013	1/2	1/2	9	31.5	32.5	16	21	21.5	10

* Artículos en común con la serie 57000 para tubos métricos
 * Items in common with series 57000 for metric tubes

89226

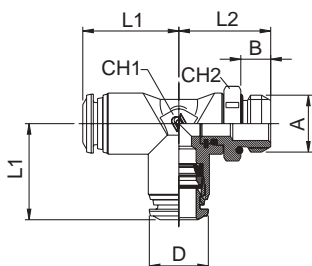
RACOR A T ORIENTABLE MACHO LATERAL CILÍNDRICO - ORIENTING TEE MALE ADAPTOR (PARALLEL) OFF - SET LEG

Código Code	Tubo Tube	A	B	L1	L2	CH1	CH2	D	Conf. Pack.
8922600001	1/8	10/32	3.5	16.5	17	9	8	10	10
8922600002	5/32	10/32	3.5	17	18	9	8	10	10
8922600003	1/4	10/32	3.5	21	20.5	11	11	12.5	10

89230

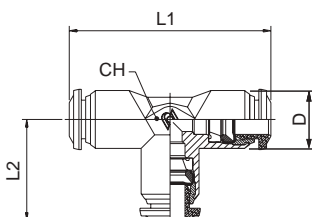
RACOR A T INTERMEDIO - TEE CONNECTOR

Código Code	Tubo Tube	L1	L2	CH	D	Conf. Pack.
8923000001	1/8	33	17	9	10	10
*5723000001	5/32 (4)	34	17	9	14	10
8923000003	1/4	42	21	11	12.5	10
*5723000003	5/16 (8)	45	22.5	13	10	10
8923000005	3/8	53	26.5	16	17.5	10
8923000006	1/2	61	30.5	19	21.5	10

* Artículos en común con la serie 57000 para tubos métricos
 * Items in common with series 57000 for metric tubes

89310

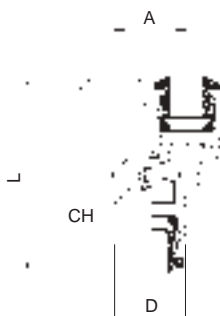
RACOR A Y INTERMEDIO - Y CONNECTOR

Código Code	Tubo Tube	A	L	CH	D	Conf. Pack.
8931000001	1/8	10	29	11	10	10
*5731000001	5/32 (4)	11	32	11	10	10
8931000003	1/4	13.5	36.5	13	12.5	10
*5731000003	5/16 (8)	15.5	41	13	14	10
8931000005	3/8	18.5	48	18	17.5	10

* Artículos en común con la serie 57000 para tubos métricos
 * Items in common with series 57000 for metric tubes

89500

ANILLO ORIENTABLE SIMPLE - SINGLE BANJO BODY



Código Code	Tubo Tube	A	B	L	CH	Conf. Pack.
575000003	5/32 (4)	1/8	15	21	14	10
575000001	5/32 (4)	10/32	12.5	19	-	10
895000002	1/8	1/8	15	19	14	10
895000004	1/4	1/8	15	22.5	14	10
895000005	1/4	1/4	17	25	18	10
895000006	3/8	1/4	17	29	18	10
895000007	3/8	3/8	20	30.5	21	10
895000008	1/2	3/8	20	32	21	10
895000009	1/2	1/2	24	35	25	10

* Artículos en común con la serie 57000 para tubos métricos
 * Items in common with series 57000 for metric tubes

89700

REDUCCIÓN - REDUCER

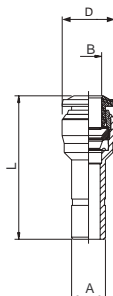

Código Code	A	B	L	D	Conf. Pack.
897000001	1/4	1/8	30	8.5	10
897000002	1/4	5/32	30	10.5	10
897000003	3/8	1/4	35.5	17	10
897000004	1/2	1/4	43	12.5	10
897000005	1/2	3/8	43	17.5	10
897000006	3/8	5/16	36.5	17	10

50990

LLAVE DE DESMONTAJE - TOOL FOR DISASSEMBLING

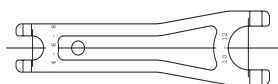

Código Code	Conf. Pack.
509900001	10

50006

JUNTA DE CIERRE PARA ROSCAS CÓNICAS - THREAD PACKING FOR TAPER THREADS



Código Code	Rosca Thread	Conf. Pack.
5000600240200	1/8	10
5000600240300	1/4	10
5000600240400	3/8	10
5000600240500	1/2	10

Note:



58000

Serie 58000

RACORDAJE AUTOMÁTICO PARA ALTA PRESIÓN
HIGHT PRESSURE PUSH-IN FITTINGS

Características Técnicas / Technical Characteristics

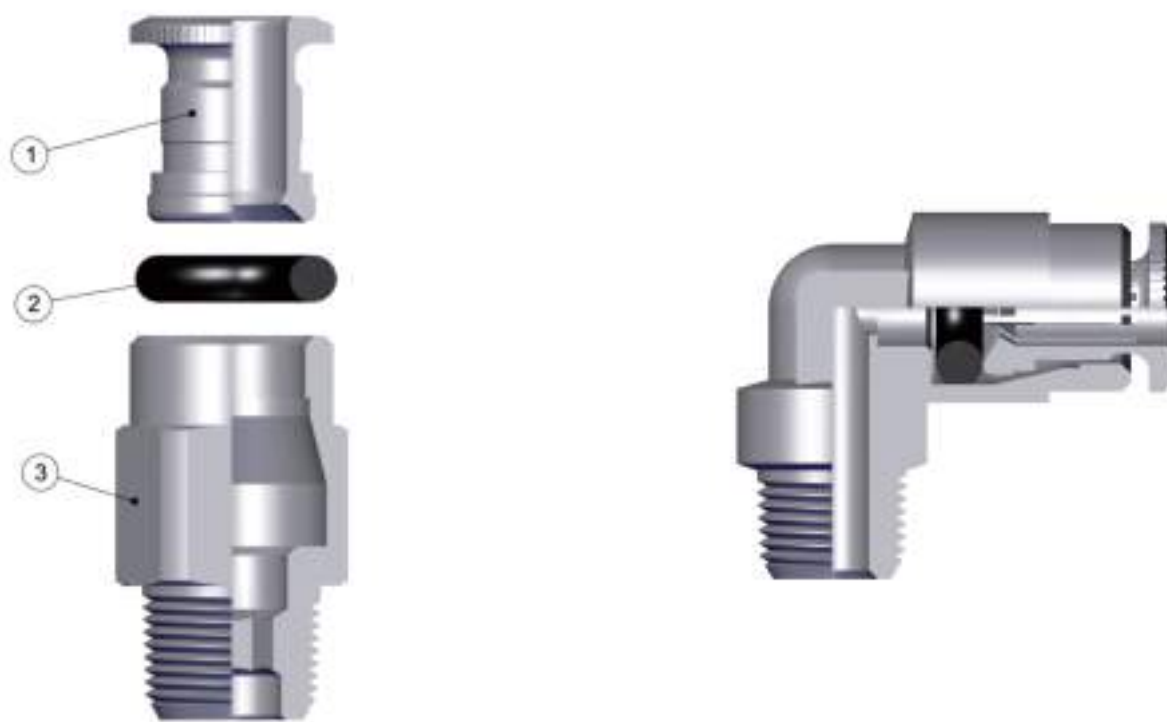

Materiales y Componentes / Component Parts and Materials

1 Pinza en latón niquelado

2 Junta tórica O-Ring en HNBR

3 Cuerpo en latón niquelado

1 Nickel-plated Brass Collet

2 HNBR O-RING Seal

3 Nickel-plated Brass Body

Presiones / Pressures

Presión mínima / Minimum pressure: **0 bar (0 MPa)**

Presión máxima con fluidos : **150 bar (15 MPa)**
Maximum pressure with fluids: 150 bar (15 MPa)

Presión máxima con aire: * **30 bar (3 MPa)**

Maximum pressure with air: * 30 bar (3 MPa)

Roscas / Threads

Gas cónica conforme ISO 7.1, BS 21, DIN 2999 / Tapered gas in conformity with ISO7.1, BS 21, DIN 2999.
Métrica cónica conforme UNI 7707 / Metric Tapered in conformity with UNI 7707.

Tubos de conexión / Connection Tubes

Tubos en material plástico:
PA6, PA66 per Alta Presión.

* PA6, PA11, PA 12, Polietileno, Poliuretano;etc.

Plastic tubes:
PA6, PA66 for Hight Pressure.

* PA6, PA11, PA12, Polyethylene, Polyurethane.

Temperaturas / Temperatures

Temperatura mínima / Minimum temperature: - 30 °C
Temperatura máxima / Maximum temperature: +130 °C

Fluidos compatibles / Fluids

Aceite / Oil
Agua / Water
Grasa / Grease

* Aire comprimido / Compressed air.

58000

RACOR RECTO MACHO CÓNICO - STRAIGHT MALE ADAPTOR (TAPER)

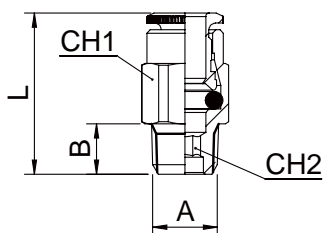

Código Code	Tubo Tube	A	B	L	CH1	CH2	Conf. Pack.
580000001	4 M6x1	6	22	10	2.5	25	
580000002	4 M8x1	6	20	10	3	25	
580000003	4 M10x1	6.5	20	10	3	25	
580000004	4 1/8	7.5	21	10	3	25	
580000005	6 M6x1	6	24.5	12	2.5	25	
580000006	6 M8x1	6	24.5	12	3	25	
580000007	6 M10x1	6.5	21.5	12	3	25	
580000008	6 1/8	7.5	23	12	3	25	

58040

RACOR RECTO INTERMEDIO - STRAIGHT CONNECTOR

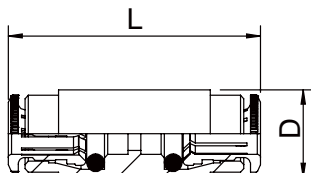

Código Code	Tubo Tube	L	Conf. Pack.
580400001	4	34.5	25
580400002	6	37.5	25

58100

RACOR A L MACHO CÓNICO - ELBOW MALE ADAPTOR (TAPER)

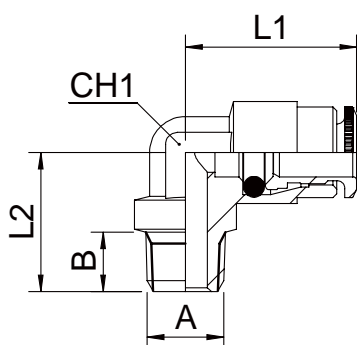

Código Code	Tubo Tube	A	B	L1	L2	CH1	D	Conf. Pack.
581000001	4 M6x1	6	18	15	8	10.5	25	
581000002	4 M8x1	6	18	15	8	10.5	25	
581000003	4 M10x1	6.5	18	15	8	10.5	25	
581000004	4 1/8	7.5	18	15	8	10.5	25	
581000005	6 M6x1	6	21	17	10	13	25	
581000006	6 M8x1	6	21	17	10	13	25	
581000007	6 M10x1	6.5	21	17	10	13	25	
581000008	6 1/8	7.5	21	17.5	10	13	25	

58111

RACOR A L ORIENTABLE MACHO CÓNICO - ORIENTING ELBOW MALE ADAPTOR (TAPER)

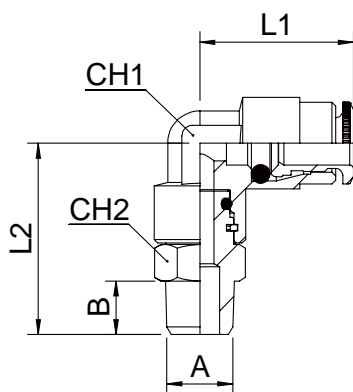

Código Code	Tubo Tube	A	B	L1	L2	CH1	CH2	D	Conf. Pack.
581110001	4 M6x1	6	18	22.5	8	11	10.5	25	
581110002	4 M8x1	6	18	22.5	8	11	10.5	25	
581110003	4 M10x1	6.5	18	22.5	8	11	10.5	25	
581110004	4 1/8	7.5	18	24	8	11	10.5	25	
581110005	6 M6x1	6	21	25.5	10	11	13	25	
581110006	6 M8x1	6	21	25.5	10	11	13	25	
581110007	6 M10x1	6.5	21	22.5	10	11	13	25	
581110008	6 1/8	7.5	21	27	10	11	13	25	



1000

Serie 1000

RACORDAJE RÁPIDO
PUSH-ON FITTINGS

Características Técnicas / Technical Characteristics

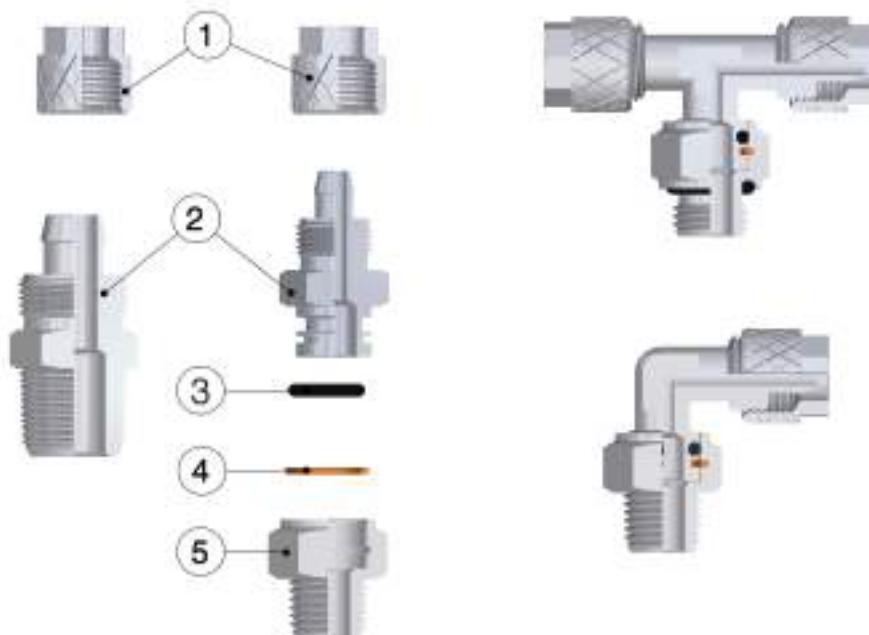

Materiales y Componentes / Component Parts and Materials

- | | |
|---------------------------------|----------------------------|
| 1 Tuerca en latón niquelado | 1 Nickel-plated Brass Nut |
| 2 Cuerpo en latón niquelado | 2 Nickel-plated Brass Body |
| 3 Junta tórica O-Ring en NBR 70 | 3 NBR 70 O-RING Seals |
| 4 Seeger en bronce | 4 Bronze Seeger |
| 5 Base en latón niquelado | 5 Nickel-plated Brass Base |

EN NINGÚN CASO LOS RACORES "GIRATORIOS" DEBEN SER EMPLEADOS COMO ROTATIVOS.
 UNDER NO CIRCUMSTANCES, THE "SWIVEL" FITTINGS CAN BE USED AS REVOLVING JOINTS.

Presiones y Temperaturas / Pressures and Temperatures

Presión y temperatura son determinadas en función del tubo empleado, por tanto estos valores se definen en base a las características del mismo tubo.

The working pressures and working temperatures depend on which type of tube is used, for this reason, the values must be determined in accordance with the tube's features.

Para los racores de la versión "giratoria" los valores son:

For the "swivel" fittings, the values are:

Presiones / Pressures

Presión mínima / Minimum pressure: **-0.99 bar (-0.099 MPa)**

Presión máxima / Maximum pressure: **15 bar (1.5 MPa)**

Roscas / Threads

Gas cónica conforme ISO 7.1, BS 21, DIN 2999

Tapered gas in conformity with ISO 7.1, BS 21, DIN 2999.

Gas cilíndrica conforme ISO 228 Clase A

Parallel gas in conformity with ISO 228 Class A.

Métrica conforme ISO R/262

Metric in conformity with ISO R/262.

Fluidos compatibles / Fluids

Aire comprimido. Fluidos y líquidos a baja presión compatibles con el tipo de conexión.

Compressed air. Fluids and liquids at low pressure compatible with the connection.

Tubos de conexión / Connection Tubes

Tubos en material plástico:

PA6, PA11, PA 12, Polietileno, Poliuretano;etc. PVC trenzado.

Plastic tubes:

PA6, PA11, PA12, Polyethylene, Polyurethane, Braided PVC.

Temperaturas / Temperatures

Temperatura mínima / Minimum temperature: **-20 °C**

Temperatura máxima / Maximum temperature: **+80 °C**

Montaje / Assembling

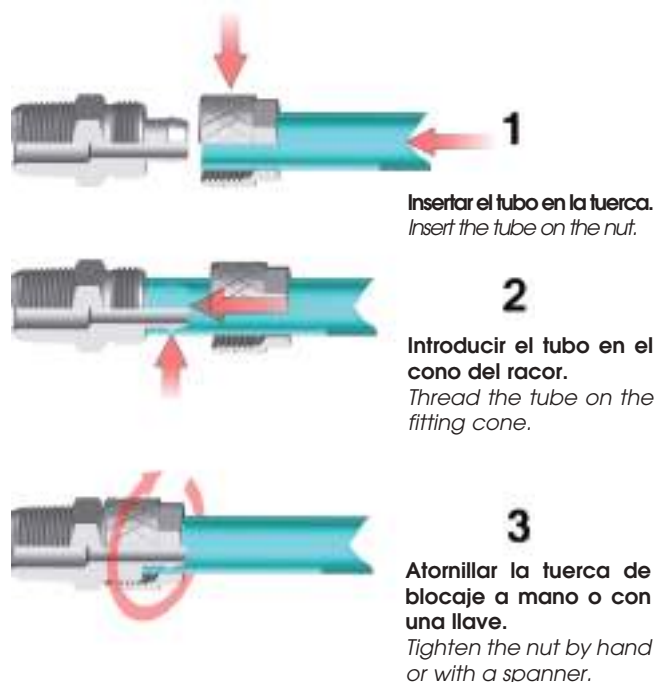

1000

RACOR RECTO MACHO CÓNICO - STRAIGHT MALE ADAPTOR (TAPER)

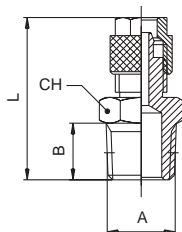

Código Code	Tubo Tube	A	B	L	CH	Conf. Pack.
010000001	4/2.7	1/8	7.5	23.5	12	50
010000002	5/3	1/8	7.5	23	12	50
010000003	6/4	1/8	7.5	25.6	12	50
010000004	6/4	1/4	11	29.6	14	50
010000005	6/4	3/8	11.5	30	17	25
010000006	8/6	1/8	7.5	26.9	14	50
010000007	8/6	1/4	11	30.9	14	50
010000008	8/6	3/8	11.5	31.4	17	25
010000009	8/6	1/2	14	34	22	25
010000010	10/8	1/8	7.5	29	14	50
010000011	10/8	1/4	11	33	14	25
010000012	10/8	3/8	11.5	33.5	17	25
010000013	10/8	1/2	14	36.5	22	25
010000014	12/10	3/8	11.5	35	17	25
010000015	12/10	1/2	14	38	22	25
010000016	15/12.5	1/2	14	40	22	25

1010

RACOR RECTO ORIENTABLE MACHO CÓNICO - ORIENTING STRAIGHT MALE ADAPTOR (TAPER)

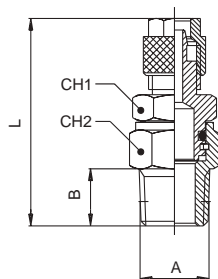

Código Code	Tubo Tube	A	B	L	CH1	CH2	Conf. Pack.
010100001	6/4	1/8	7.5	33.5	12	13	50
010100002	6/4	1/4	11	40	14	15	50
010100003	8/6	1/8	7.5	33.5	12	13	50
010100004	8/6	1/4	11	40	14	15	25
010100007	10/6.5	1/4	11	41	14	15	25
010100005	10/8	1/4	11	41	14	15	25
010100008	12/8	3/8	11.5	43.5	17	17	25
010100006	12/10	3/8	11.5	43.5	17	17	25

Medidas específicas para tubo en POLIURETANO.
Particular sizes for the POLYURETHANE tubing.

Para tubo en POLIURETANO de 8/5 aconsejamos el uso de nuestra medida standard 8/6.
For the POLYURETHANE tube 8/5 we suggest to use the standard size 8/6.

1015

RACOR RECTO ORIENTABLE MACHO CILÍNDRICO CON TÓRICA - ORIENTING STRAIGHT MALE ADAPTOR (PARALLEL)

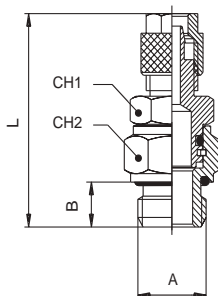

Código Code	Tubo Tube	A	B	L	CH1	CH2	Conf. Pack.
010150001	6/4	1/8	6	34	12	13	50
010150002	6/4	1/4	8	38	14	16	50
010150003	8/6	1/8	6	34	12	13	50
010150004	8/6	1/4	8	38	14	16	25
010150005	10/6.5	1/4	8	40	14	16	25
010150006	10/8	1/4	8	39	14	16	25
010150007	12/8	3/8	9	42.5	17	18	25
010150008	12/10	3/8	9	42.5	17	18	25

Medidas específicas para tubo en POLIURETANO.
Particular sizes for the POLYURETHANE tubing.

Para tubo en POLIURETANO de 8/5 aconsejamos el uso de nuestra medida standard 8/6.
For the POLYURETHANE tube 8/5 we suggest to use the standard size 8/6.

1020

RACOR RECTO MACHO CILÍNDRICO CON TÓRICA - STRAIGHT MALE ADAPTOR (PARALLEL)

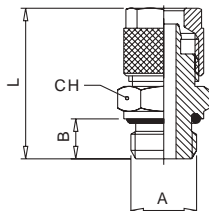

Código Code	Tubo Tube	A	B	L	CH	Conf. Pack.
010200001	4/2.7	1/8	6	23	13	50
010200002	5/3	1/8	6	25.1	13	50
010200003	6/4	1/8	6	25.1	13	50
010200004	6/4	1/4	8	28.1	16	50
010200005	6/4	3/8	9	29.1	19	25
010200006	6/4	1/2	10	32	24	25
010200007	8/6	1/8	6	26.4	14	50
010200008	8/6	1/4	8	29.4	16	25
010200009	8/6	3/8	9	30.4	19	25
010200010	8/6	1/2	10	32	24	25
010200011	10/8	1/8	6	28.5	14	25
010200012	10/8	1/4	8	31.5	16	25
010200013	10/8	3/8	9	32.5	19	25
010200014	10/8	1/2	10	34.5	24	25
010200015	12/10	3/8	9	34	19	25
010200016	12/10	1/2	10	36	24	25
010200017	15/12.5	1/2	10	38	24	25

1021

RACOR RECTO MACHO CON TÓRICA CON ROSCA MÉTRICA - STRAIGHT MALE ADAPTOR WITH METRIC THREAD

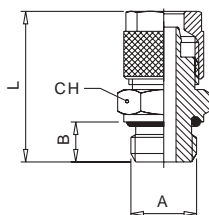

Código Code	Tubo Tube	A	B	L	CH	Conf. Pack.
010210001	4/2.7	M5	4	20.5	8	50
010210002	4/2.7	M6	5	21.5	8	50
010210003	5/3	M5	4	23.1	8	50
010210004	5/3	M6	5	23.1	8	50
010210005	6/4	M5	4	23.1	8	50
010210006	6/4	M6	5	23.1	8	50
010210007	6/4	M12x1	8	28.1	15	25
010210008	6/4	M12x1.25	8	28.1	15	25
010210009	6/4	M12x1.5	8	28.1	15	25

1025

RACOR RECTO MACHO CÓNICO + TUERCA CON MUELLE - STRAIGHT MALE ADAPTOR (TAPER) + NUT AND SPRING

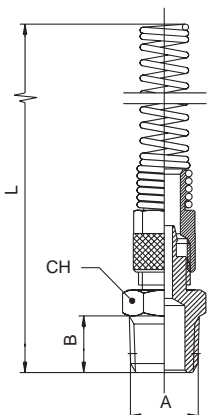

Código Code	Tubo Tube	A	B	L	CH	Conf. Pack.
010250001	6/4	1/8	7.5	108	12	25
010250002	6/4	1/4	11	112.5	14	25
010250003	8/6	1/8	7.5	113.5	14	25
010250004	8/6	1/4	11	118	14	25
010250005	8/6	3/8	11.5	119	17	25
010250006	8/6	1/2	14	121	22	25
010250007	10/8	1/8	7.5	122	14	25
010250008	10/8	1/4	11	126	14	25
010250009	10/8	3/8	11.5	127	17	25
010250010	10/8	1/2	14	130	22	25
010250011	12/10	3/8	11.5	134	17	25
010250012	12/10	1/2	14	137	22	25

1026

RACOR RECTO ORIENTABLE MACHO CÓNICO + TUERCA CON MUELLE - ORIENTING STRAIGHT MALE ADAPTOR (TAPER) + NUT AND SPRING

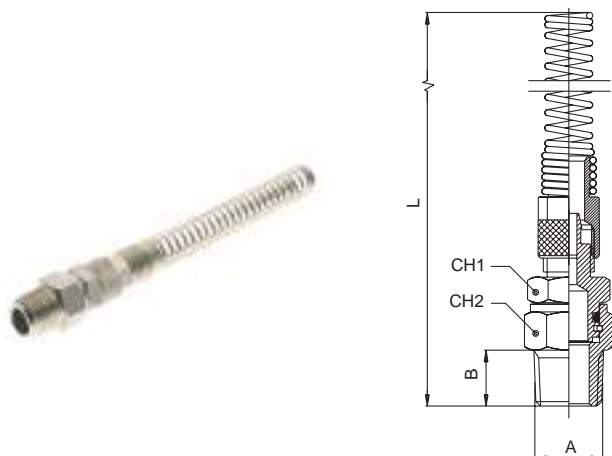

Código Code	Tubo Tube	A	B	L	CH1	CH2	Conf. Pack.
0102600001	6/4	1/8	7.5	117.5	12	13	25
0102600002	6/4	1/4	11	121	14	15	25
0102600003	8/6	1/8	7.5	121	12	13	25
0102600004	8/6	1/4	11	128	14	15	25
0102600005	10/6.5	1/4	11	135	14	15	25
0102600006	10/8	1/4	11	136	14	15	25
0102600007	12/8	3/8	11.5	144	17	17	25
0102600008	12/10	3/8	11.5	144	17	17	25

Medidas específicas para tubo en POLIURETANO.
Particular sizes for the POLYURETHANE tubing.

Para tubo en POLIURETANO de 8/5 aconsejamos el uso de nuestra medida standard 8/6.
For the POLYURETHANE tube 8/5 we suggest to use the standard size 8/6.

1027

RACOR RECTO ORIENTABLE MACHO CILÍNDRICO CON TÓRICA + TUERCA CON MUELLE - ORIENTING STRAIGHT MALE ADAPTOR (PARALLEL) + NUT AND SPRING

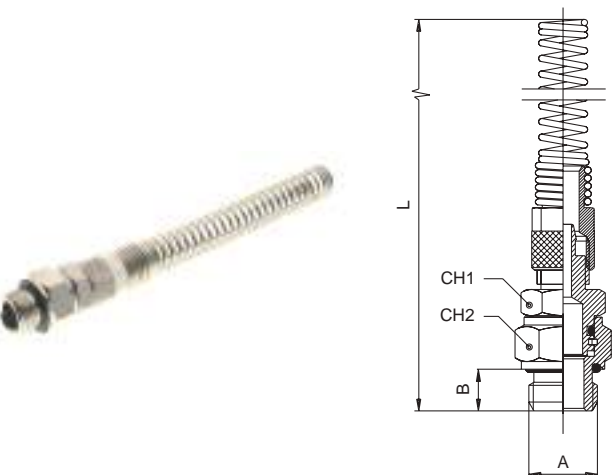

Código Code	Tubo Tube	A	B	L	CH1	CH2	Conf. Pack.
0102700001	6/4	1/8	6	116	12	13	25
0102700002	6/4	1/4	8	121	14	16	25
0102700003	8/6	1/8	6	122	12	13	25
0102700004	8/6	1/4	8	126	14	16	25
0102700005	10/6.5	1/4	8	134	14	16	25
0102700006	10/8	1/4	8	134	14	16	25
0102700007	12/8	3/8	9	143	17	18	25
0102700008	12/10	3/8	9	142	17	18	25

Medidas específicas para tubo en POLIURETANO.
Particular sizes for the POLYURETHANE tubing.

Para tubo en POLIURETANO de 8/5 aconsejamos el uso de nuestra medida standard 8/6.
For the POLYURETHANE tube 8/5 we suggest to use the standard size 8/6.

1028

RACOR RECTO MACHO CILÍNDRICO CON TÓRICA + TUERCA CON MUELLE - STRAIGHT MALE ADAPTOR (PARALLEL) + NUT AND SPRING

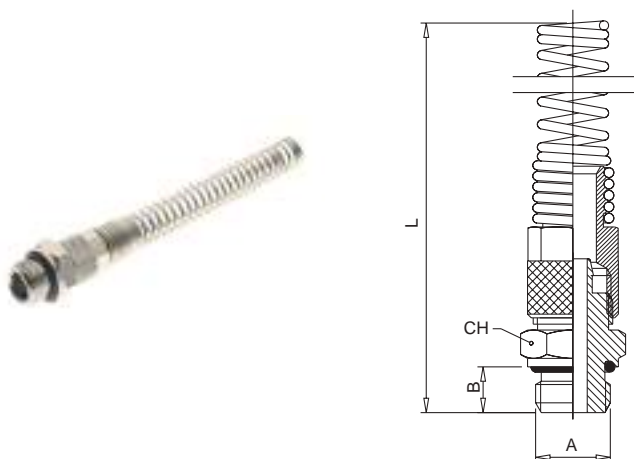

Código Code	Tubo Tube	A	B	L	CH	Conf. Pack.
0102800001	6/4	1/8	6	109	13	25
0102800002	6/4	1/4	8	111	16	25
0102800003	6/4	3/8	9	112	19	25
0102800004	6/4	1/2	10	114	24	25
0102800005	8/6	1/8	6	114	14	25
0102800006	8/6	1/4	8	116.5	16	25
0102800007	8/6	3/8	9	117.5	19	25
0102800008	8/6	1/2	10	119.5	24	25
0102800009	10/8	1/8	6	121.5	14	25
0102800010	10/8	1/4	8	125.5	16	25
0102800011	10/8	3/8	9	125.5	19	25
0102800012	10/8	1/2	10	128.5	24	25
0102800013	12/10	3/8	9	133	19	25
0102800014	12/10	1/2	10	134.5	24	25

1029

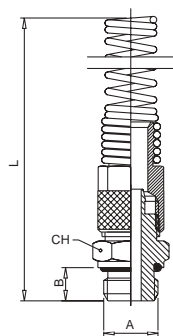
RACOR RECTO MACHO CON ROSCA MÉTRICA + TUERCA CON MUELLE - STRAIGHT MALE ADAPTOR WITH METRIC THREAD + NUT AND SPRING

Código Code	Tubo Tube	A	B	L	CH	Conf. Pack.
010290001	6/4	M12x1	8	111	15	25
010290002	6/4	M12x1.25	8	111	15	25
010290003	6/4	M12x1.5	8	111	15	25

1030

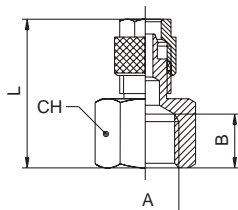
RACOR RECTO HEMBRA - STRAIGHT FEMALE ADAPTOR

Código Code	Tubo Tube	A	B	L	CH	Conf. Pack.
010300001	6/4	1/8	8.5	23.3	14	50
010300002	6/4	1/4	11	27	17	50
010300003	6/4	3/8	11.5	28	22	25
010300004	8/6	1/8	8	24.7	14	50
010300005	8/6	1/4	11	28.7	17	25
010300006	8/6	3/8	11.5	29.2	22	25
010300007	8/6	1/2	15.5	33	24	25
010300008	10/8	1/4	11	30.5	17	25
010300009	10/8	3/8	11.5	31	22	25
010300010	10/8	1/2	15.5	34.5	24	25
010300011	12/10	3/8	11.5	32.5	22	25

1035

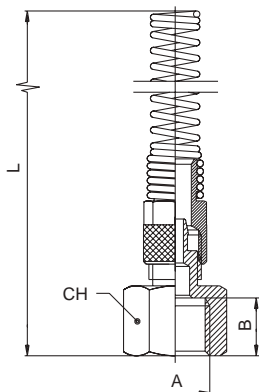
RACOR RECTO HEMBRA + TUERCA CON MUELLE - STRAIGHT FEMALE ADAPTOR + NUT AND SPRING

Código Code	Tubo Tube	A	B	L	CH	Conf. Pack.
010350001	6/4	1/8	8.5	106	14	25
010350002	6/4	1/4	11	109	17	25
010350003	6/4	3/8	11.5	110	22	25
010350004	8/6	1/8	8	112	14	25
010350005	8/6	1/4	11	115.5	17	25
010350006	8/6	3/8	11.5	116	22	25
010350007	8/6	1/2	15.5	119.5	24	25
010350008	10/8	1/4	11	123	17	25
010350009	10/8	3/8	11.5	124.5	22	25
010350010	10/8	1/2	15.5	128.5	24	25
010350011	12/10	3/8	11.5	131	22	25

1040

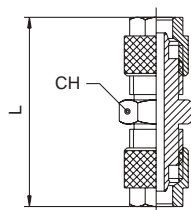
RACOR RECTO INTERMEDIO - STRAIGHT CONNECTOR

Código Code	Tubo Tube	Tubo Tube	L	CH	Conf. Pack.
010400001	4/2.7		27.5	8	50
010400002	5/3		31.7	8	50
010400003	6/4	5/3	32.2	12	50
010400004	6/4		32.2	12	50
010400005	8/6	6/4	33.5	12	25
010400006	8/6		34.8	12	25
010400007	10/8	6/4	35.6	14	25
010400008	10/8	8/6	36.9	14	25
010400009	10/8		39	14	25
010400010	12/10		43	17	25
010400011	15/12.5		47	22	25

1050

RACOR RECTO INTERMEDIO PASATABIQUES - BULKHEAD CONNECTOR

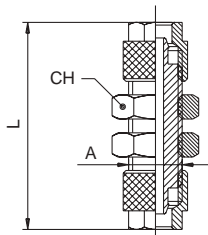

Código Code	Tubo Tube	A	L	CH	Conf. Pack.
010500001	4/2.7	M6x0.5	35	10	50
010500002	5/3	M7x0.75	35	10	50
010500003	6/4x5/3	M10x1	45.5	14	50
010500004	6/4	M10x1	45.5	14	25
010500005	8/6x6/4	M12x1	47.3	17	25
010500006	8/6	M12x1	48.4	17	25
010500007	10/8x6/4	M14x1	49.8	17	25
010500008	10/8x8/6	M14x1	51.2	17	25
010500009	10/8	M14x1	52	17	25
010500010	12/10	M16x1	57	19	25
010500011	15/12.5	M20x1	59	24	25

1100

RACOR A L MACHO CÓNICO - ELBOW MALE ADAPTOR (TAPER)

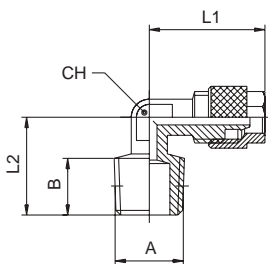

Código Code	Tubo Tube	A	B	L1	L2	CH	Conf. Pack.
011000001	4/2.7	1/8	7.5	19.5	15	8	50
011000002	5/3	1/8	7.5	19.5	15	8	50
011000003	6/4	1/8	7.5	19.5	15	8	50
011000004	6/4	1/4	11	20.6	19	8	50
011000005	6/4	3/8	11.5	21	21	9	25
011000006	8/6	1/8	7.5	19.9	16.5	9	50
011000007	8/6	1/4	11	21.9	19	9	50
011000008	8/6	3/8	11.5	23.4	21	9	25
011000009	8/6	1/2	14	26	28	16	25
011000010	10/8	1/8	7.5	25	18	11	25
011000011	10/8	1/4	11	24	22	11	25
011000012	10/8	3/8	12.5	25.5	22.5	11	25
011000013	10/8	1/2	14	28	28	16	25
011000014	12/10	3/8	11.5	27	22.5	13	25
011000015	12/10	1/2	14	30	28	16	25
011000016	15/12.5	1/2	14	31.5	28	16	25

1101

RACOR A L MACHO CON ROSCA MÉTRICA - ELBOW MALE ADAPTOR WITH METRIC THREAD

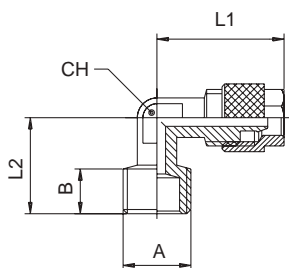

Código Code	Tubo Tube	A	B	L1	L2	CH	Conf. Pack.
011010001	6/4	M12x1	11	20.6	19	8	25
011010002	6/4	M12x1.25	11	20.6	19	8	25
011010003	6/4	M12x1.5	11	20.6	19	8	25

1110

RACOR A L ORIENTABLE MACHO CÓNICO - ORIENTING ELBOW MALE ADAPTOR (TAPER)

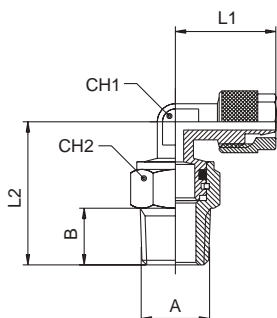

Código Code	Tubo Tube	A	B	L1	L2	CH1	CH2	Conf. Pack.
011100006	4/2.7	1/8	7.5	20	22.5	8	13	50
011100001	6/4	1/8	7.5	20.6	22.5	8	13	50
011100002	6/4	1/4	11	20.6	28	8	15	25
011100003	8/6	1/8	7.5	21.6	22.5	9	13	25
011100004	8/6	1/4	11	23.1	28.5	9	15	25
011100005	10/8	1/4	11	24	30.5	11	15	25

1115

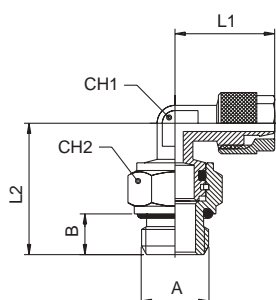
RACOR A L ORIENTABLE MACHO CILÍNDRICO CON TÓRICA - ORIENTING ELBOW MALE ADAPTOR (PARALLEL)

Código Code	Tubo Tube	A	B	L1	L2	CH1	CH2	Conf. Pack.
0111500006	4/2.7	1/8	6	18.5	22	8	13	50
0111500001	6/4	1/8	6	20.6	22	8	13	50
0111500002	6/4	1/4	8	20.6	26	8	16	25
0111500003	8/6	1/8	6	21.6	21.6	9	13	25
0111500004	8/6	1/4	8	23.1	26.5	9	16	25
0111500005	10/8	1/4	8	24	27.5	11	16	25

1120

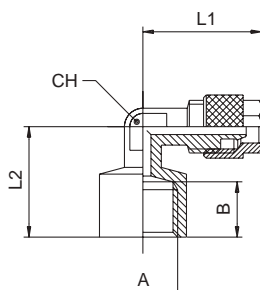
RACOR A L HEMBRA - ELBOW FEMALE ADAPTOR

Código Code	Tubo Tube	A	B	L1	L2	CH	Conf. Pack.
0112000001	5/3	1/8	8.5	20.6	18	8	50
0112000002	6/4	1/8	8.5	20.6	18	8	50
0112000003	6/4	1/4	10.5	21	21	9	25
0112000004	8/6	1/8	8.5	21.9	19	9	25
0112000005	8/6	1/4	10.5	23.4	21	9	25
0112000006	10/8	1/4	10.5	25.5	22.5	11	25
0112000007	10/8	3/8	11.5	28	27	16	25

1130

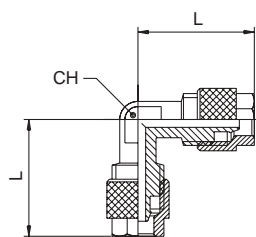
RACOR A L INTERMEDIO - ELBOW CONNECTOR

Código Code	Tubo Tube	Tubo Tube	L	CH	Conf. Pack.
0113000001	4/2.7		20	8	50
0113000002	5/3		20.6	8	50
0113000003	6/4		20.6	8	50
0113000004	8/6	6/4	21.9	9	25
0113000005	8/6		21.9	9	25
0113000006	10/8		25.5	11	25
0113000007	12/10		27	13	25
0113000008	15/12.5		33.5	16	25

1200

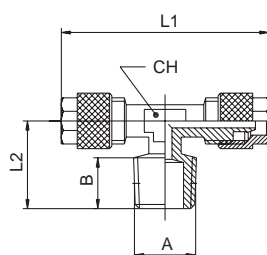
RACOR A T MACHO CENTRAL CÓNICO - TEE MALE ADAPTOR (TAPER) - CENTRE LEG

Código Code	Tubo Tube	A	B	L1	L2	CH	Conf. Pack.
0120000001	4/2.7	1/8	7.5	37	15.5	8	50
0120000002	5/3	1/8	7.5	39	15.5	8	50
0120000003	6/4	1/8	7.5	39	15.5	8	50
0120000004	6/4	1/4	11	41.2	19	8	25
0120000005	8/6	1/8	7.5	39.8	16.5	9	25
0120000006	8/6	1/4	11	43.8	20.5	9	25
0120000007	10/8	1/8	7.5	48	19	11	25
0120000008	10/8	1/4	11	48	22	11	25
0120000009	10/8	3/8	11.5	51	22	11	25
0120000010	12/10	3/8	11.5	54	22.5	14	25
0120000011	15/12.5	1/2	14	63	28	16	25

1210

RACOR A T ORIENTABLE MACHO CENTRAL CÓNICO - ORIENTING TEE MALE ADAPTOR (TAPER) - CENTRE LEG

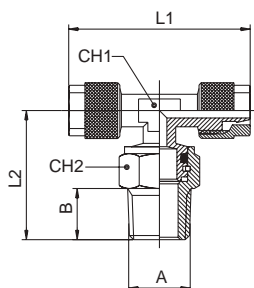

Código Code	Tubo Tube	A	B	L1	L2	CH1	CH2	Conf. Pack.
0121000001	6/4	1/8	7.5	41.2	22.5	8	13	25
0121000002	6/4	1/4	11	41.2	28	8	15	25
0121000003	8/6	1/8	7.5	43.2	24.5	9	13	25
0121000004	8/6	1/4	11	43.2	29.5	9	15	25
0121000005	10/8	1/4	11	48	29.5	11	15	25

1215

RACOR A T ORIENTABLE MACHO CENTRAL CILÍNDRICO CON TÓRICA - ORIENTING TEE MALE ADAPTOR (PARALLEL) - CENTRE LEG

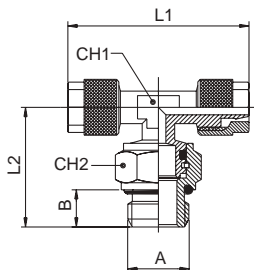

Código Code	Tubo Tube	A	B	L1	L2	CH1	CH2	Conf. Pack.
0121500001	6/4	1/8	6	41.2	22	8	13	25
0121500002	6/4	1/4	8	41.2	26	8	16	25
0121500003	8/6	1/8	6	43.2	24	9	13	25
0121500004	8/6	1/4	8	43.2	27.5	9	16	25
0121500006	10/8	1/8	6	48	22.5	11	13	25
0121500005	10/8	1/4	8	48	27.5	11	16	25

1220

RACOR A T MACHO LATERAL CÓNICO - TEE MALE ADAPTOR (TAPER) - OFF SET LEG

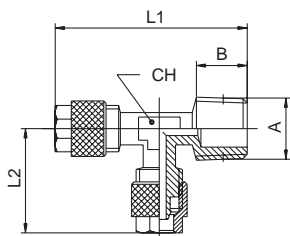

Código Code	Tubo Tube	A	B	L1	L2	CH	Conf. Pack.
0122000001	5/3	1/8	7.5	36.7	20.6	8	50
0122000002	6/4	1/8	7.5	36.7	20.6	8	25
0122000003	6/4	1/4	11	40.2	20.6	8	25
0122000004	8/6	1/8	7.5	38	21.9	9	25
0122000005	8/6	1/4	11	41.5	21.9	9	25
0122000006	10/8	1/8	7.5	40	25.5	11	25
0122000007	10/8	1/4	11	43	25.5	11	25
0122000008	10/8	3/8	11.5	44	25.5	11	25
0122000009	12/10	3/8	11.5	48.5	28	13	25
0122000010	15/12.5	1/2	14	57.5	32.5	16	25

1230

RACOR A T INTERMEDIO - TEE CONNECTOR

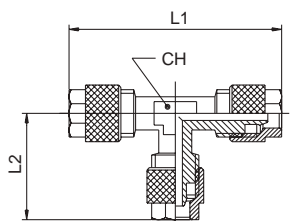

Código Code	Tubo Tube	L1	L2	CH	Conf. Pack.	
0123000001	4/2.7	40	20.5	8	50	
0123000002	5/3	41.2	20.6	8	50	
0123000003	6/4	41.2	20.6	8	25	
0123000004	8/6	6/4	43.8	20.6	9	25
0123000005	8/6	43.8	21.9	9	25	
0123000006	10/8	6/4	51	20.6	11	25
0123000007	10/8	8/6	51	21.9	11	25
0123000008	10/8	51	25.5	11	25	
0123000009	12/10	54	28	13	25	
0123000010	15/12.5	63	32.5	16	25	

1300

RACOR A CRUZ INTERMEDIO - EQUAL CROSS CONNECTOR

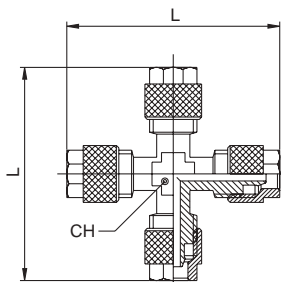

Código Code	Tubo Tube	L	CH	Conf. Pack.
013000001	5/3	41.6	8	50
013000002	6/4	41.6	8	25
013000003	8/6	44.4	9	25
013000004	10/8	49	11	25
013000005	12/10	58	13	25
013000006	15/12.5	64	17	25

51410

TORNILLO SIMPLE - BANJO STEM SINGLE

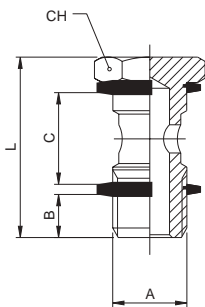

Código Code	A	B	C	L	CH	Conf. Pack.
514100011	M5	4	12.5	22	8	25
514100012	M6	5	12.5	23	8	25
514100013	1/8	6	15	28	14	25
514100014	1/4	8	17	32	17	25
514100015	3/8	9	20	36	19	25
514100016	1/2	10	24	42	24	25
514100017	*M12x1.5	8	17	32	17	25

ESTE ARTÍCULO VIENE COMPLETO DE ARANDELAS EN NYLON (ART.1610).
* CON ESTE TORNILLO UTILIZAR EL ANILLO ORIENTABLE DE 1/4.

THIS ITEM WILL BE SUPPLIED WITH THE NYLON WASHERS ART. 1610.
* WITH THIS BANJO STEM USING THE 1/4 ORIENTING BANJO BODY.

51420

TORNILLO DOBLE - BANJO STEM DOUBLE

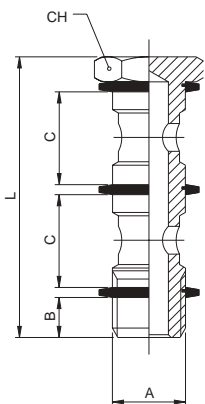

Código Code	A	B	C	L	CH	Conf. Pack.
514200011	1/8	6	15	44.5	14	25
514200012	1/4	8	17	50.5	17	25
514200013	3/8	9	20	58	19	25
514200014	1/2	10	24	68	24	25
514200015	*M12x1.5	8	17	50.5	17	25

ESTE ARTÍCULO VIENE COMPLETO DE ARANDELAS EN NYLON (ART.1610).
* CON ESTE TORNILLO UTILIZAR EL ANILLO ORIENTABLE DE 1/4.

THIS ITEM WILL BE SUPPLIED WITH THE NYLON WASHERS ART. 1610.
* WITH THIS BANJO STEM USING THE 1/4 ORIENTING BANJO BODY.

51430

TORNILLO TRIPLE - BANJO STEM TRIPLE

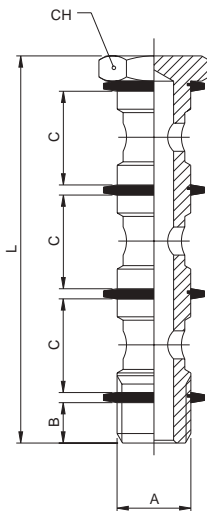

Código Code	A	B	C	L	CH	Conf. Pack.
514300011	1/8	6	15	61	14	25
514300012	1/4	8	17	69	17	25
514300013	3/8	9	20	80	19	25
514300014	1/2	10	24	94	24	10

ESTE ARTÍCULO VIENE COMPLETO DE ARANDELAS EN NYLON (ART.1610).
THIS ITEM WILL BE SUPPLIED WITH THE NYLON WASHERS ART. 1610.

51440

TORNILLO SIMPLE MACHO - HEMBRA - MALE - FEMALE BANJO STEM SINGLE

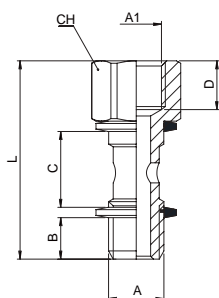

Código Code	A	A1	B	C	D	L	CH	Conf. Pack.
514400001	1/8	1/8	6	15	8.5	34.5	14	25
514400002	1/4	1/4	8	17	11	40.5	17	25
514400003	3/8	3/8	9	20	12	45.5	19	25

ESTE ARTÍCULO VIENE COMPLETO DE ARANDELAS EN NYLON (ART.1610).
THIS ITEM WILL BE SUPPLIED WITH THE NYLON WASHERS ART. 1610.

1500

ANILLO ORIENTABLE SIMPLE - SINGLE BANJO BODY

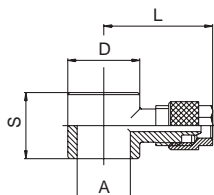

Código Code	Tubo Tube	A	D	S	L	Conf. Pack.
015000001	4/2.7	M5	9	12.5	21.5	50
015000002	4/2.7	M6	9	12.5	21.5	10
015000003	4/2.7	1/8	14	15	22.5	50
015000004	5/3	M5	9	12.5	22	50
015000005	5/3	1/8	14	15	22.5	50
015000006	6/4	M5	9	12.5	22	50
015000007	6/4	M6	9	12.5	22	10
015000008	6/4	1/8	14	15	23	50
015000009	6/4	1/4	18	17	25	50
015000010	6/4	3/8	21	20	27	25
015000011	8/6	1/8	14	15	24.5	50
015000012	8/6	1/4	18	17	26	25
015000013	8/6	3/8	21	20	27	25
015000014	8/6	1/2	26	24	31	25
015000015	10/8	1/8	14	15	27.5	25
015000016	10/8	1/4	18	17	27.5	25
015000017	10/8	3/8	21	20	30.5	25
015000018	10/8	1/2	26	24	34	25
015000019	12/10	3/8	21	20	31.5	25
015000020	12/10	1/2	26	24	35	25
015000021	15/12.5	1/2	26	24	36.5	25

1510

ANILLO ORIENTABLE DOBLE - DOUBLE BANJO BODY

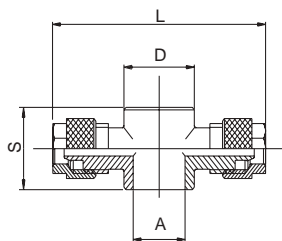

Código Code	Tubo Tube	A	D	S	L	Conf. Pack.
015100001	4/2.7	M5	9	12.5	43	50
015100002	4/2.7	1/8	14	15	43	50
015100003	5/3	M5	9	12.5	43	50
015100004	5/3	1/8	14	15	46.6	50
015100005	6/4	M5	9	12.5	43	50
015100006	6/4	1/8	14	15	46.6	50
015100007	6/4	1/4	18	17	50.6	25
015100008	6/4	3/8	21	20	53.6	25
015100009	8/6	1/8	14	15	49.4	25
015100010	8/6	1/4	18	17	55.2	25
015100011	8/6	3/8	21	20	55	25
015100012	8/6	1/2	26	24	61	25
015100013	10/8	1/8	14	15	53	25
015100014	10/8	1/4	18	17	59	25
015100015	10/8	3/8	21	20	61	25
015100016	10/8	1/2	26	24	66	25
015100017	12/10	3/8	21	20	63	25
015100018	12/10	1/2	26	24	70	25
015100019	15/12.5	1/2	26	24	73	25

LG 410

TORNILLO SIMPLE SERIE LIGERA - BANJO STEM SINGLE LIGHT

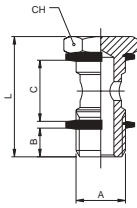

Código Code	A	B	C	L	CH	Conf. Pack.
LG4100002	M5	3.5	9	18	8	25
LG4100003	M6	4	9	19	8	25

ESTE ARTÍCULO VIENE COMPLETO DE ARANDELAS EN NYLON PA66 ART. 1610.
THIS ITEM WILL BE SUPPLIED WITH THE PA66 WASHERS ART. 1610.

LG 500

ANILLO ORIENTABLE SIMPLE SERIE LIGERA - SINGLE BANJO BODY LIGHT



Código Code	Tubo Tube	A	D	S	L	Conf. Pack.
LG5000003	4/2.7	M5	9	9	17	50
LG5000005	4/2.7	M6	9	9	17	50
LG5000004	5/3	M5	9	9	17	50
LG5000002	6/4	M5	9	9	16.5	50
LG5000006	6/4	M6	9	9	16.5	50

1600

ARANDELA EN ALUMINIO - ALUMINIUM WASHER

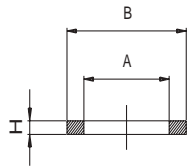

Código Code	Medida Size	A	B	H	Conf. Pack.
016000011B500	M5	5.2	8	1	25
0160000110200	1/8	10	14	1.5	25
0160000110300	1/4	13.5	18	1.5	25
0160000110400	3/8	16.8	21	1.5	25
0160000110500	1/2	21.1	26	1.5	25
016000011D700	M12	12.5	18	1.5	25

1610

ARANDELA DENTADA EN NYLON PA66 - PA66 NOTCHED-WASHER

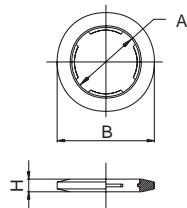

Código Code	Medida Size	A	B	H	Conf. Pack.
016100025A700	M3	2.5	5.5	0.5	25
016100025B500	M5	5.2	8	1	25
016100025B800	M6	6.1	9	1.3	25
0161000250200	1/8	10	14	1.5	25
0161000250300	1/4	13.5	18	1.5	25
0161000250400	3/8	16.8	21	1.5	25
0161000250500	1/2	21.1	26	2	25
0161000250700	3/4	27	32	2.5	25
0161000250900	1"	34	41	2.5	25

1612

ARANDELA BIMATERIAL EN ACERO Y NBR - STEEL AND NBR BIMATERIAL WASHER

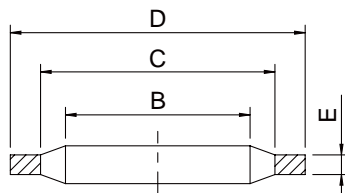

CARACTERÍSTICAS TÉCNICAS / TECHNICAL CHARACTERISTICS

Temperatura mínima / minimum temperature: **-30°C**

Temperatura máxima / maximum temperature: **+100°C**

Código Code	A	B	C	D	E	Conf. Pack.
0161200001	1/8	10.4	12	14.7	1.25	25
0161200002	1/4	13.85	15.75	18.7	1.25	25
0161200003	3/8	17.35	19.25	22.7	1.25	25
0161200004	1/2	21.65	23.55	26.7	1.25	25
0161200005	3/4	27.3	29.2	32.5	1.25	25
0161200006	1"	34.2	36.1	39.5	2	25

1700

TUERCA DE BLOCAJE - LOCKING NUT

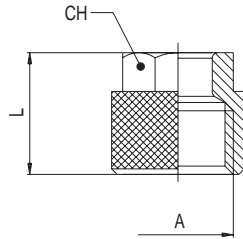

Código Code	Medida Size	A	L	CH	Conf. Pack.
0170000013ZNB	4/2.7	M6x0.5	9	7	50
0170000016ZNB	5/3	M7x0.75	11	8	50
0170000019ZNB	6/4	M8x0.75	11	8	50
0170000010XNB	6/4	M10x1	11	10	50
0170000014XNB	8/6	M12x1	11.5	12	50
0170000015XNB	10/8	M14x1	13.5	14	50
0170000016XNB	12/10	M16x1	15	15	50
0170000017XNB	15/12.5	M20x1	16	19	50

1710

TUERCA DE BLOCAJE CON MUELLE - LOCKING NUT WITH SPRING

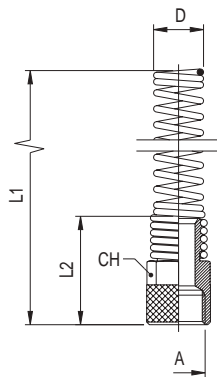

Código Code	Tubo Tube	A	D	L1	L2	CH	Conf. Pack.
0171000001	6/4	M10x1	9.4	93	20	11	25
0171000002	8/6	M12x1	11.4	98.5	21	13	25
0171000003	10/8	M14x1	13.4	107	24	14	25
0171000004	12/10	M16x1	16	116.5	27.5	17	25

1750

CORTATUBOS EN PLÁSTICO - PLASTIC PIPE CUTTER

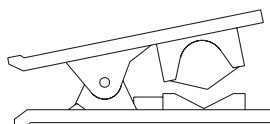

Código Code	Conf. Pack.
0175000001	10

8610

TAPÓN - PLUG

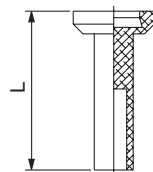

Código Code	Tubo Tube	L	Conf. Pack.
086100031X1RO	4	23.5	25
086100031X3RO	5	24.5	25
086100031X4RO	6	24.5	25
086100031X7RO	8	26	25
086100031X9RO	10	28.5	25
086100031Y1RO	12	28.5	25



Serie **Function**

RACORDAJE A FUNCIONES NEUMÁTICAS
FUNCTION FITTINGS

Reguladores de Caudal Serie 50000 - 55000 - 57000

Flow Regulators Valves 50000 - 55000 - 5700

Características Técnicas / Technical Characteristics



Presiones / Pressures

Presión mínima / Minimum pressure: **1 bar (0.1 MPa)**
 Presión máxima / Maximum pressure: **10 bar (1 MPa)**

Temperaturas / Temperatures

Temperatura mínima / Minimum temperature: **-20 °C**
 Temperatura máxima / Maximum temperature: **+80 °C**

Roscas / Threads

Gas Cilíndrica conforme ISO 228 clase A.
 Parallel gas in conformity with ISO 228 class A.

Tubos de conexión / Connection Tubes

Tubos en material plástico:
 PA6, PA11, PA12, Polietileno, *Poliuretano; etc.
 *Para tubos en poliuretano es aconsejada una dureza de 98 shore.
 Plastic tubes:
 PA6, PA11, PA12, Polyethylene, *Polyurethane, ecc.
 *For Polyurethane hoses it is required a minimum hardness of 98 shore.

Fluidos compatibles / Fluids

Aire comprimido / Compressed air.

**UNIDIRECCIONAL
 PARA CILINDRO
 UNI-DIRECTIONAL
 FOR CYLINDER**

**UNIDIRECCIONAL
 PARA VÁLVULA
 UNI-DIRECTIONAL
 FOR VALVE**

**BIDIRECCIONAL
 BI-DIRECTIONAL**

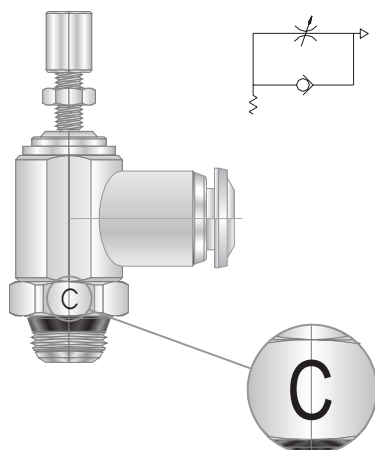

Código / Code
 50901 - 55901 - 57901
 50905 - 55905 - 57905

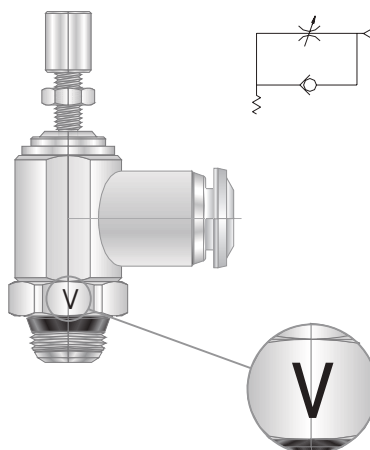

Código / Code
 50910 - 55910 - 57910
 50915 - 55915 - 57915

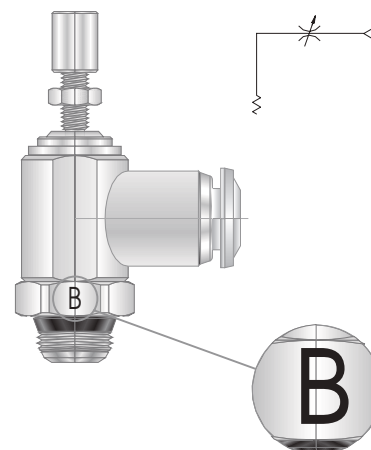

Código / Code
 50920 - 55920 - 57920
 50925 - 55925 - 57925

50901

REGULADOR UNIDIRECCIONAL ORIENTABLE PARA CILINDRO SHORT, REGULACIÓN A DESTORNILLADOR
ORIENTING FLOW REGULATOR FOR CILINDER (SHORT) SCREWDRIVER REGULATION

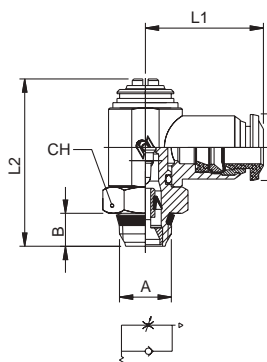

Código Code	Tubo Tube	A	B	L1	L2	CH	D	Conf. Pack.
5090100001	3	M5	4	19	29.5	8	10	10
5090100002	4	M5	4	19	29.5	8	10	10
5090100003	4	1/8	5.5	21	31	14	10	10
5090100004	5	M5	4	20	29.5	8	12.5	10
5090100005	5	1/8	5.5	21.5	31	14	12.5	10
5090100006	5	1/4	7	24.5	36.5	17	12.5	10
5090100007	6	M5	4	20.5	29.5	8	12.5	10
5090100008	6	1/8	5.5	22.5	31	14	12.5	10
5090100009	6	1/4	7	25	36.5	17	12.5	10
5090100010	8	1/8	5.5	24	31	14	14	10
5090100011	8	1/4	7	26	36.5	17	14	10
5090100016	8	3/8	7.5	28.5	42.5	20	14	10
5090100017	10	1/4	7	28.5	36.5	17	17	10
5090100012	10	3/8	7.5	30.5	42.5	20	17	10
5090100013	12	3/8	7.5	32.5	42.5	20	21.5	10
5090100014	12	1/2	9	35	47	24	21.5	10
5090100015	14	1/2	9	35.5	47	24	21.5	10

50910

REGULADOR UNIDIRECCIONAL ORIENTABLE PARA VÁLVULA SHORT, REGULACIÓN A DESTORNILLADOR
ORIENTING FLOW REGULATOR FOR VALVE (SHORT) SCREWDRIVER REGULATION

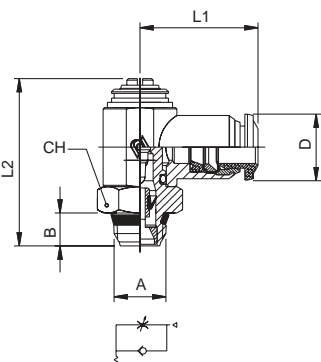

Código Code	Tubo Tube	A	B	L1	L2	CH	D	Conf. Pack.
5091000001	3	M5	4	19	29.5	8	10	10
5091000002	4	M5	4	19	29.5	8	10	10
5091000003	4	1/8	5.5	21	31	14	10	10
5091000004	5	M5	4	20	29.5	8	12.5	10
5091000005	5	1/8	5.5	21.5	31	14	12.5	10
5091000006	5	1/4	7	24.5	36.5	17	12.5	10
5091000007	6	M5	4	20.5	29.5	8	12.5	10
5091000008	6	1/8	5.5	22.5	31	14	12.5	10
5091000009	6	1/4	7	25	36.5	17	12.5	10
5091000010	8	1/8	5.5	24	31	14	14	10
5091000011	8	1/4	7	26	36.5	17	14	10
5091000016	8	3/8	7.5	28.5	42.5	20	14	10
5091000017	10	1/4	7	28.5	36.5	17	17	10
5091000012	10	3/8	7.5	30.5	42.5	20	17	10
5091000013	12	3/8	7.5	32.5	42.5	20	21.5	10
5091000014	12	1/2	9	35	47	24	21.5	10
5091000015	14	1/2	9	35.5	47	24	21.5	10

50920

REGULADOR BIDIRECCIONAL ORIENTABLE SHORT, REGULACIÓN A DESTORNILLADOR
ORIENTING BI-DIRECTIONAL FLOW REGULATOR (SHORT) SCREWDRIVER REGULATION

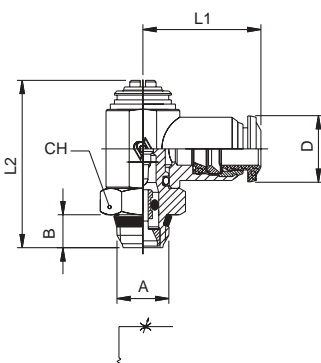

Código Code	Tubo Tube	A	B	L1	L2	CH	D	Conf. Pack.
5092000001	3	M5	4	19	29.5	8	10	10
5092000002	4	M5	4	19	29.5	8	10	10
5092000003	4	1/8	5.5	21	31	14	10	10
5092000004	5	M5	4	20	29.5	8	12.5	10
5092000005	5	1/8	5.5	21.5	31	14	12.5	10
5092000006	5	1/4	7	24.5	36.5	17	12.5	10
5092000007	6	M5	4	20.5	29.5	8	12.5	10
5092000008	6	1/8	5.5	22.5	31	14	12.5	10
5092000009	6	1/4	7	25	36.5	17	12.5	10
5092000010	8	1/8	5.5	24	31	14	14	10
5092000011	8	1/4	7	26	36.5	17	14	10
5092000016	8	3/8	7.5	28.5	42.5	20	14	10
5092000017	10	1/4	7	28.5	36.5	17	17	10
5092000012	10	3/8	7.5	30.5	42.5	20	17	10
5092000013	12	3/8	7.5	32.5	42.5	20	21.5	10
5092000014	12	1/2	9	35	47	24	21.5	10
5092000015	14	1/2	9	35.5	47	24	21.5	10

50905

REGULADOR UNIDIRECCIONAL ORIENTABLE PARA CILINDRO SHORT, REGULACIÓN MANUAL ORIENTING FLOW REGULATOR FOR CILINDER (SHORT) MANUAL REGULATION

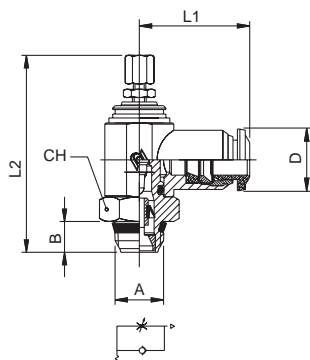

Código Code	Tubo Tube	A	B	L1	L2min	L2max	CH	D	Conf. Pack.
509050001	3	M5	4	19	38.5	42.5	8	10	10
509050002	4	M5	4	19	38.5	42.5	8	10	10
509050003	4	1/8	5.5	21	44	49	14	10	10
509050004	5	M5	4	20	38.5	42.5	8	12.5	10
509050005	5	1/8	5.5	21.5	44	49	14	12.5	10
509050006	5	1/4	7	24.5	48.5	55	17	12.5	10
509050007	6	M5	4	20.5	38.5	42.5	8	12.5	10
509050008	6	1/8	5.5	22.5	44	49	14	12.5	10
509050009	6	1/4	7	25	48.5	55	17	12.5	10
509050010	8	1/8	5.5	24	44	49	14	14	10
509050011	8	1/4	7	26	48.5	55	17	14	10
509050016	8	3/8	7.5	28.5	56	65	20	14	10
509050017	10	1/4	7	28.5	48.5	55	17	17	10
509050012	10	3/8	7.5	30.5	56	65	20	17	10
509050013	12	3/8	7.5	32.5	56	65	20	21.5	10
509050014	12	1/2	9	35	62	69	24	21.5	10
509050015	14	1/2	9	35.5	62	69	24	21.5	10

50915

REGULADOR UNIDIRECCIONAL ORIENTABLE PARA VÁLVULA SHORT, REGULACIÓN MANUAL ORIENTING FLOW REGULATOR FOR VALVE (SHORT) MANUAL REGULATION

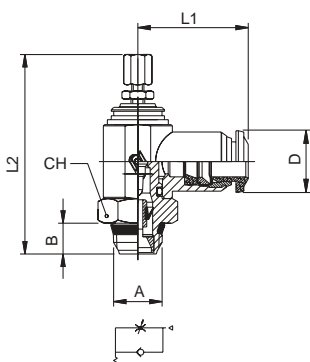

Código Code	Tubo Tube	A	B	L1	L2min	L2max	CH	D	Conf. Pack.
509150001	3	M5	4	19	38.5	42.5	8	10	10
509150002	4	M5	4	19	38.5	42.5	8	10	10
509150003	4	1/8	5.5	21	44	49	14	10	10
509150004	5	M5	4	20	38.5	42.5	8	12.5	10
509150005	5	1/8	5.5	21.5	44	49	14	12.5	10
509150006	5	1/4	7	24.5	48.5	55	17	12.5	10
509150007	6	M5	4	20.5	38.5	42.5	8	12.5	10
509150008	6	1/8	5.5	22.5	44	49	14	12.5	10
509150009	6	1/4	7	25	48.5	55	17	12.5	10
509150010	8	1/8	5.5	24	44	49	14	14	10
509150011	8	1/4	7	26	48.5	55	17	14	10
509150016	8	3/8	7.5	28.5	56	65	20	14	10
509150017	10	1/4	7	28.5	48.5	55	17	17	10
509150012	10	3/8	7.5	30.5	56	65	20	17	10
509150013	12	3/8	7.5	32.5	56	65	20	21.5	10
509150014	12	1/2	9	35	62	69	24	21.5	10
509150015	14	1/2	9	35.5	62	69	24	21.5	10

50925

REGULADOR BIDIRECCIONAL ORIENTABLE SHORT, REGULACIÓN MANUAL ORIENTING BI-DIRECTIONAL FLOW REGULATOR (SHORT) MANUAL REGULATION

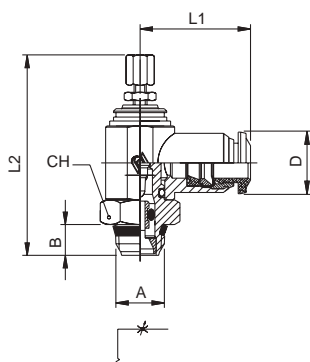

Código Code	Tubo Tube	A	B	L1	L2min	L2max	CH	D	Conf. Pack.
509250001	3	M5	4	19	38.5	42.5	8	10	10
509250002	4	M5	4	19	38.5	42.5	8	10	10
509250003	4	1/8	5.5	21	44	49	14	10	10
509250004	5	M5	4	20	38.5	42.5	8	12.5	10
509250005	5	1/8	5.5	21.5	44	49	14	12.5	10
509250006	5	1/4	7	24.5	48.5	55	17	12.5	10
509250007	6	M5	4	20.5	38.5	42.5	8	12.5	10
509250008	6	1/8	5.5	22.5	44	49	14	12.5	10
509250009	6	1/4	7	25	48.5	55	17	12.5	10
509250010	8	1/8	5.5	24	44	49	14	14	10
509250011	8	1/4	7	26	48.5	55	17	14	10
509250016	8	3/8	7.5	28.5	56	65	20	14	10
509250017	10	1/4	7	28.5	48.5	55	17	17	10
509250012	10	3/8	7.5	30.5	56	65	20	17	10
509250013	12	3/8	7.5	32.5	56	65	20	21.5	10
509250014	12	1/2	9	35	62	69	24	21.5	10
509250015	14	1/2	9	35.5	62	69	24	21.5	10

55900

REGULADOR UNIDIRECCIONAL ORIENTABLE PARA CILINDRO SHORT, REGULACIÓN A DESTORNILLADOR ORIENTING FLOW REGULATOR FOR CILINDER (SHORT) SCREWDRIVER REGULATION

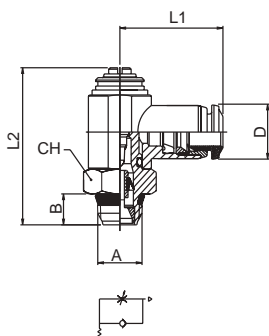

Código Code	Tubo Tube	A	B	L1	L2	CH	D	Conf. Pack.
559000002	4	M5	5.5	19.5	29.5	8	10	10
559000003	4	1/8	5.5	21.5	31	14	10	10
559000004	5	M5	5.5	20.5	29.5	8	12.5	10
559000005	5	1/8	5.5	22.5	31	14	12.5	10
559000006	5	1/4	7	25	36.5	17	12.5	10
559000007	6	M5	5.5	21	29.5	8	12.5	10
559000008	6	1/8	5.5	23	31	14	12.5	10
559000009	6	1/4	7	25.5	36.5	17	12.5	10
559000010	8	1/8	5.5	23.5	31	14	14	10
559000011	8	1/4	7	26	36.5	17	14	10
559000012	8	3/8	8.5	27.5	42.5	20	14	10
559000013	10	3/8	8.5	30.5	42.5	20	17	10
559000014	12	3/8	8.5	32.5	42.5	20	21.5	10
559000015	12	1/2	10	35	47	24	21.5	10

55910

REGULADOR UNIDIRECCIONAL ORIENTABLE PARA VÁLVULA SHORT, REGULACIÓN A DESTORNILLADOR ORIENTING FLOW REGULATOR FOR VALVE (SHORT) SCREWDRIVER REGULATION

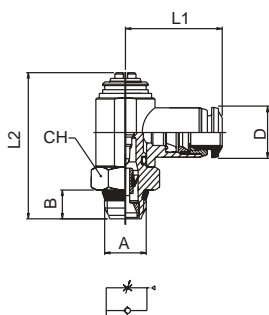

Código Code	Tubo Tube	A	B	L1	L2	CH	D	Conf. Pack.
559100002	4	M5	5.5	19.5	29.5	8	10	10
559100003	4	1/8	5.5	21.5	31	14	10	10
559100004	5	M5	5.5	20.5	29.5	8	12.5	10
559100005	5	1/8	5.5	22.5	31	14	12.5	10
559100006	5	1/4	7	25	36.5	17	12.5	10
559100007	6	M5	5.5	21	29.5	8	12.5	10
559100008	6	1/8	5.5	23	31	14	12.5	10
559100009	6	1/4	7	25.5	36.5	17	12.5	10
559100010	8	1/8	5.5	23.5	31	14	14	10
559100011	8	1/4	7	26	36.5	17	14	10
559100012	8	3/8	8.5	27.5	42.5	20	14	10
559100013	10	3/8	8.5	30.5	42.5	20	17	10
559100014	12	3/8	8.5	32.5	42.5	20	21.5	10
559100015	12	1/2	10	35	47	24	21.5	10

55920

REGULADOR BIDIRECCIONAL ORIENTABLE SHORT, REGULACIÓN A DESTORNILLADOR ORIENTING BI-DIRECTIONAL FLOW REGULATOR (SHORT) SCREWDRIVER REGULATION

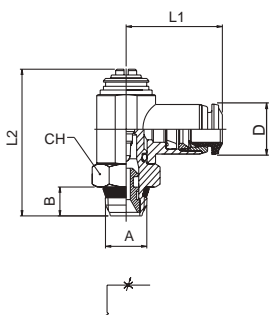

Código Code	Tubo Tube	A	B	L1	L2	CH	D	Conf. Pack.
559200002	4	M5	5.5	19.5	29.5	8	10	10
559200003	4	1/8	5.5	21.5	31	14	10	10
559200004	5	M5	5.5	20.5	29.5	8	12.5	10
559200005	5	1/8	5.5	22.5	31	14	12.5	10
559200006	5	1/4	7	25	36.5	17	12.5	10
559200007	6	M5	5.5	21	29.5	8	12.5	10
559200008	6	1/8	5.5	23	31	14	12.5	10
559200009	6	1/4	7	25.5	36.5	17	12.5	10
559200010	8	1/8	5.5	23.5	31	14	14	10
559200011	8	1/4	7	26	36.5	17	14	10
559200012	8	3/8	8.5	27.5	42.5	20	14	10
559200013	10	3/8	8.5	30.5	42.5	20	17	10
559200014	12	3/8	8.5	32.5	42.5	20	21.5	10
559200015	12	1/2	10	35	47	24	21.5	10

55905

REGULADOR UNIDIRECCIONAL ORIENTABLE PARA CILINDRO SHORT, REGULACIÓN MANUAL ORIENTING FLOW REGULATOR FOR CILINDER (SHORT) MANUAL REGULATION

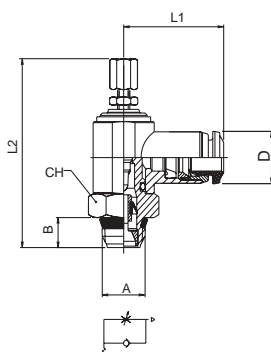

Código Code	Tubo Tube	A	B	L1	L2min	L2max	CH	D	Conf. Pack.
559050002	4	M5	5.5	19.5	38.5	42.5	8	10	10
559050003	4	1/8	5.5	21.5	44	49	14	10	10
559050004	5	M5	5.5	20.5	38.5	42.5	8	12.5	10
559050005	5	1/8	5.5	22.5	44	49	14	12.5	10
559050006	5	1/4	7	25	48.5	55	17	12.5	10
559050007	6	M5	5.5	21	38.5	42.5	8	12.5	10
559050008	6	1/8	5.5	23	44	49	14	12.5	10
559050009	6	1/4	7	25.5	48.5	55	17	12.5	10
559050010	8	1/8	5.5	23.5	44	49	14	14	10
559050011	8	1/4	7	26	48.5	55	17	14	10
559050012	8	3/8	8.5	27.5	56	65	20	14	10
559050013	10	3/8	8.5	30.5	56	65	20	17	10
559050014	12	3/8	8.5	32.5	56	65	20	21.5	10
559050015	12	1/2	10	35	62	69	24	21.5	10

55915

REGULADOR UNIDIRECCIONAL ORIENTABLE PARA VÁLVULA SHORT, REGULACIÓN MANUAL ORIENTING FLOW REGULATOR FOR VALVE (SHORT) MANUAL REGULATION

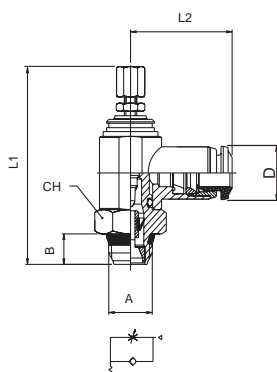

Código Code	Tubo Tube	A	B	L1	L2min	L2max	CH	D	Conf. Pack.
559150002	4	M5	5.5	19.5	38.5	42.5	8	10	10
559150003	4	1/8	5.5	21.5	44	49	14	10	10
559150004	5	M5	5.5	20.5	38.5	42.5	8	12.5	10
559150005	5	1/8	5.5	22.5	44	49	14	12.5	10
559150006	5	1/4	7	25	48.5	55	17	12.5	10
559150007	6	M5	5.5	21	38.5	42.5	8	12.5	10
559150008	6	1/8	5.5	23	44	49	14	12.5	10
559150009	6	1/4	7	25.5	48.5	55	17	12.5	10
559150010	8	1/8	5.5	23.5	44	49	14	14	10
559150011	8	1/4	7	26	48.5	55	17	14	10
559150012	8	3/8	8.5	27.5	56	65	20	14	10
559150013	10	3/8	8.5	30.5	56	65	20	17	10
559150014	12	3/8	8.5	32.5	56	65	20	21.5	10
559150015	12	1/2	10	35	62	69	24	21.5	10

55925

REGULADOR BIDIRECCIONAL ORIENTABLE SHORT, REGULACIÓN MANUAL ORIENTING BI-DIRECTIONAL FLOW REGULATOR (SHORT) MANUAL REGULATION

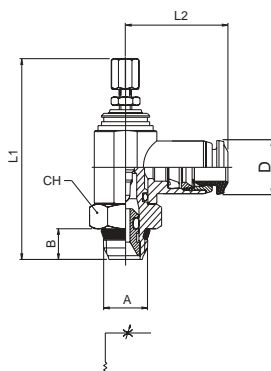

Código Code	Tubo Tube	A	B	L1	L2min	L2max	CH	D	Conf. Pack.
559250002	4	M5	5.5	19.5	38.5	42.5	8	10	10
559250003	4	1/8	5.5	21.5	44	49	14	10	10
559250004	5	M5	5.5	20.5	38.5	42.5	8	12.5	10
559250005	5	1/8	5.5	22.5	44	49	14	12.5	10
559250006	5	1/4	7	25	48.5	55	17	12.5	10
559250007	6	M5	5.5	21	38.5	42.5	8	12.5	10
559250008	6	1/8	5.5	23	44	49	14	12.5	10
559250009	6	1/4	7	25.5	48.5	55	17	12.5	10
559250010	8	1/8	5.5	23.5	44	49	14	14	10
559250011	8	1/4	7	26	48.5	55	17	14	10
559250012	8	3/8	8.5	27.5	56	65	20	14	10
559250013	10	3/8	8.5	30.5	56	65	20	17	10
559250014	12	3/8	8.5	32.5	56	65	20	21.5	10
559250015	12	1/2	10	35	62	69	24	21.5	10

57901

REGULADOR UNIDIRECCIONAL ORIENTABLE PARA CILINDRO SHORT, REGULACIÓN A DESTORNILLADOR ORIENTING FLOW REGULATOR FOR CILINDER (SHORT) SCREWDRIVER REGULATION

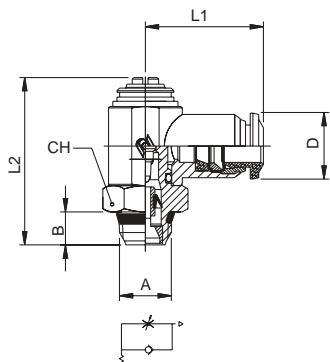

Código Code	Tubo Tube	A	B	L1	L2	CH	D	Conf. Pack.
5790100002	4	M5	4	19	29.5	8	10	10
5790100003	4	1/8	5.5	21	31	14	10	10
5790100004	5	M5	4	20	29.5	8	12.5	10
5790100005	5	1/8	5.5	21.5	31	14	12.5	10
5790100006	5	1/4	7	24.5	36.5	17	12.5	10
5790100007	6	M5	4	20.5	29.5	8	12.5	10
5790100008	6	1/8	5.5	22.5	31	14	12.5	10
5790100009	6	1/4	7	25	36.5	17	12.5	10
5790100010	8	1/8	5.5	24	31	14	14	10
5790100011	8	1/4	7	26	36.5	17	14	10
5790100016	8	3/8	7.5	28.5	42.5	20	14	10
5790100017	10	1/4	7	28.5	36.5	17	17	10
5790100012	10	3/8	7.5	30.5	42.5	20	17	10
5790100013	12	3/8	7.5	32.5	42.5	20	21.5	10
5790100014	12	1/2	9	35	47	24	21.5	10
5790100015	14	1/2	9	35.5	47	24	21.5	10

57910

REGULADOR UNIDIRECCIONAL ORIENTABLE PARA VÁLVULA SHORT, REGULACIÓN A DESTORNILLADOR ORIENTING FLOW REGULATOR FOR VALVE (SHORT) SCREWDRIVER REGULATION

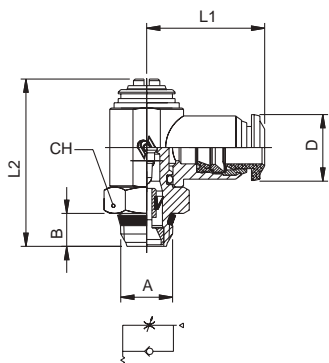

Código Code	Tubo Tube	A	B	L1	L2	CH	D	Conf. Pack.
5791000002	4	M5	4	19	29.5	8	10	10
5791000003	4	1/8	5.5	21	31	14	10	10
5791000004	5	M5	4	20	29.5	8	12.5	10
5791000005	5	1/8	5.5	21.5	31	14	12.5	10
5791000006	5	1/4	7	24.5	36.5	17	12.5	10
5791000007	6	M5	4	20.5	29.5	8	12.5	10
5791000008	6	1/8	5.5	22.5	31	14	12.5	10
5791000009	6	1/4	7	25	36.5	17	12.5	10
5791000010	8	1/8	5.5	24	31	14	14	10
5791000011	8	1/4	7	26	36.5	17	14	10
5791000016	8	3/8	7.5	28.5	42.5	20	14	10
5791000017	10	1/4	7	28.5	36.5	17	17	10
5791000012	10	3/8	7.5	30.5	42.5	20	17	10
5791000013	12	3/8	7.5	32.5	42.5	20	21.5	10
5791000014	12	1/2	9	35	47	24	21.5	10
5791000015	14	1/2	9	35.5	47	24	21.5	10

57920

REGULADOR BIDIRECCIONAL ORIENTABLE SHORT, REGULACIÓN A DESTORNILLADOR ORIENTING BI-DIRECTIONAL FLOW REGULATOR (SHORT) SCREWDRIVER REGULATION

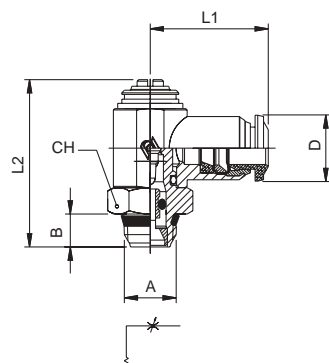

Código Code	Tubo Tube	A	B	L1	L2	CH	D	Conf. Pack.
5792000002	4	M5	4	19	29.5	8	10	10
5792000003	4	1/8	5.5	21	31	14	10	10
5792000004	5	M5	4	20	29.5	8	12.5	10
5792000005	5	1/8	5.5	21.5	31	14	12.5	10
5792000006	5	1/4	7	24.5	36.5	17	12.5	10
5792000007	6	M5	4	20.5	29.5	8	12.5	10
5792000008	6	1/8	5.5	22.5	31	14	12.5	10
5792000009	6	1/4	7	25	36.5	17	12.5	10
5792000010	8	1/8	5.5	24	31	14	14	10
5792000011	8	1/4	7	26	36.5	17	14	10
5792000016	8	3/8	7.5	28.5	42.5	20	14	10
5792000017	10	1/4	7	28.5	36.5	17	17	10
5792000012	10	3/8	7.5	30.5	42.5	20	17	10
5792000013	12	3/8	7.5	32.5	42.5	20	21.5	10
5792000014	12	1/2	9	35	47	24	21.5	10
5792000015	14	1/2	9	35.5	47	24	21.5	10

57905

REGULADOR UNIDIRECCIONAL ORIENTABLE PARA CILINDRO SHORT, REGULACIÓN MANUAL ORIENTING FLOW REGULATOR FOR CILINDER (SHORT) MANUAL REGULATION

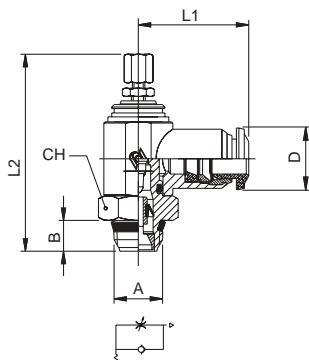

Código Code	Tubo Tube	A	B	L1	L2min	L2max	CH	D	Conf. Pack.
579050002	4	M5	4	19	38.5	42.5	8	10	10
579050003	4	1/8	5.5	21	44	49	14	10	10
579050004	5	M5	4	20	38.5	42.5	8	12.5	10
579050005	5	1/8	5.5	21.5	44	49	14	12.5	10
579050006	5	1/4	7	24.5	48.5	55	17	12.5	10
579050007	6	M5	4	20.5	38.5	42.5	8	12.5	10
579050008	6	1/8	5.5	22.5	44	49	14	12.5	10
579050009	6	1/4	7	25	48.5	55	17	12.5	10
579050010	8	1/8	5.5	24	44	49	14	14	10
579050011	8	1/4	7	26	48.5	55	17	14	10
579050016	8	3/8	7.5	28.5	56	65	20	14	10
579050017	10	1/4	7	28.5	48.5	55	17	17	10
579050012	10	3/8	7.5	30.5	56	65	20	17	10
579050013	12	3/8	7.5	32.5	56	65	20	21.5	10
579050014	12	1/2	9	35	62	69	24	21.5	10
579050015	14	1/2	9	35.5	62	69	24	21.5	10

57915

REGULADOR UNIDIRECCIONAL ORIENTABLE PARA VÁLVULA SHORT, REGULACIÓN MANUAL ORIENTING FLOW REGULATOR FOR VALVE (SHORT) MANUAL REGULATION

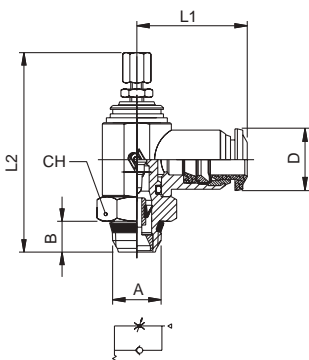

Código Code	Tubo Tube	A	B	L1	L2min	L2max	CH	D	Conf. Pack.
579150002	4	M5	4	19	38.5	42.5	8	10	10
579150003	4	1/8	5.5	21	44	49	14	10	10
579150004	5	M5	4	20	38.5	42.5	8	12.5	10
579150005	5	1/8	5.5	21.5	44	49	14	12.5	10
579150006	5	1/4	7	24.5	48.5	55	17	12.5	10
579150007	6	M5	4	20.5	38.5	42.5	8	12.5	10
579150008	6	1/8	5.5	22.5	44	49	14	12.5	10
579150009	6	1/4	7	25	48.5	55	17	12.5	10
579150010	8	1/8	5.5	24	44	49	14	14	10
579150011	8	1/4	7	26	48.5	55	17	14	10
579150016	8	3/8	7.5	28.5	56	65	20	14	10
579150017	10	1/4	7	28.5	48.5	55	17	17	10
579150012	10	3/8	7.5	30.5	56	65	20	17	10
579150013	12	3/8	7.5	32.5	56	65	20	21.5	10
579150014	12	1/2	9	35	62	69	24	21.5	10
579150015	14	1/2	9	35.5	62	69	24	21.5	10

57925

REGULADOR BIDIRECCIONAL ORIENTABLE SHORT, REGULACIÓN MANUAL ORIENTING BI-DIRECTIONAL FLOW REGULATOR (SHORT) MANUAL REGULATION

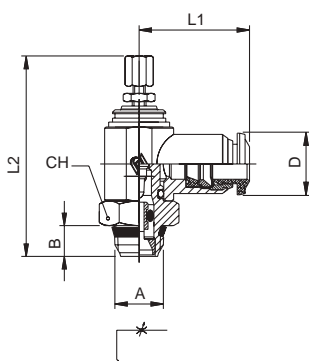

Código Code	Tubo Tube	A	B	L1	L2min	L2max	CH	D	Conf. Pack.
579250002	4	M5	4	19	38.5	42.5	8	10	10
579250003	4	1/8	5.5	21	44	49	14	10	10
579250004	5	M5	4	20	38.5	42.5	8	12.5	10
579250005	5	1/8	5.5	21.5	44	49	14	12.5	10
579250006	5	1/4	7	24.5	48.5	55	17	12.5	10
579250007	6	M5	4	20.5	38.5	42.5	8	12.5	10
579250008	6	1/8	5.5	22.5	44	49	14	12.5	10
579250009	6	1/4	7	25	48.5	55	17	12.5	10
579250010	8	1/8	5.5	24	44	49	14	14	10
579250011	8	1/4	7	26	48.5	55	17	14	10
579250016	8	3/8	7.5	28.5	56	65	20	14	10
579250017	10	1/4	7	28.5	48.5	55	17	17	10
579250012	10	3/8	7.5	30.5	56	65	20	17	10
579250013	12	3/8	7.5	32.5	56	65	20	21.5	10
579250014	12	1/2	9	35	62	69	24	21.5	10
579250015	14	1/2	9	35.5	62	69	24	21.5	10

Reguladores de Caudal Serie 8900 / Flow Regulators valves 8900 Series

Características Técnicas / Technical Characteristics



Presiones / Pressures

Presión mínima / Minimum pressure: **1 bar (0.1 MPa)**
 Presión máxima / Maximum pressure: **10 bar (1 MPa)**

Temperaturas / Temperatures

Temperatura mínima / Minimum temperature: **-20 °C**
 Temperatura máxima / Maximum temperature: **+80 °C**

Roscas / Threads

Gas Cilíndrica conforme ISO 228 clase A.
 Parallel gas in conformity with ISO 228 class A.

Tubos de conexión / Connection Tubes

Tubos compatibles con el tipo de racor montado con el regulador.
 All the tubes compatible with the fitting's features assembled on the regulator.

Fluidos compatibles / Fluids

Aire comprimido / Filtered air.

Materiales y Componentes / Component Parts and Materials

- | | |
|---|--|
| 1 Cuerpo en latón niquelado | 1 Nickel-plated Brass Body |
| 2 Junta tórica O-Ring en NBR 70 | 2 NBR 70 O-RING Seals |
| 3 Tornillo de regulación en latón niquelado | 3 Nickel-plated Brass Adjusting needle |
| 4 Tuerca de bloqueo en latón niquelado | 4 Nickel-plated Brass Locking nut |
| 5 Pomo de mando en latón niquelado | 5 Nickel-plated Brass Adjusting knob |
| 6 Junta tórica O-Ring en NBR 70 | 6 NBR 70 O-RING Seals |
| 7 Junta de labio en NBR 70 | 7 NBR 70 Lip seal |
| 8 Soporte junta en latón niquelado | 8 Nickel-plated Brass Seal support |
| 9 Arandela en nylon Art. 1610 | 9 PA66 Washer Art. 1610 |

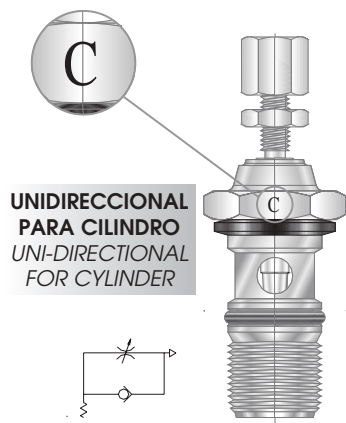

Código / Code
8900 - 8905

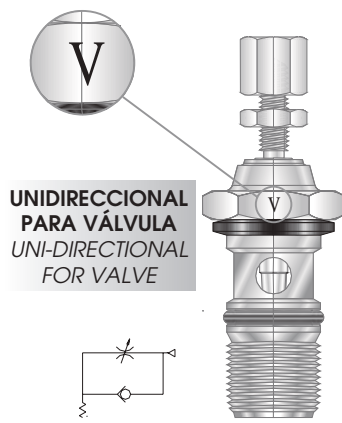

Código / Code
8910 - 8915

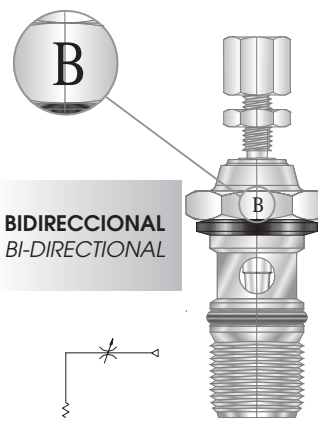

Código / Code
8920 - 8925

8900

TORNILLO REGULADOR UNIDIRECCIONAL PARA CILINDRO, REGULACIÓN A DESTORNILLADOR - *FLOW REGULATOR FOR CYLINDER. SCREWDRIVER REGULATION*

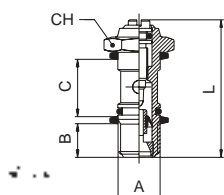

Código Code	A	B	C	L	CH	Conf. Pack.
089000001	M5	4	12.5	24	8	10
089000002	1/8	5.5	15	30.5	14	10
089000003	1/4	8.5	17	35.5	17	10
089000004	3/8	9	20	41	20	10
089000005	1/2	10	24	47	24	10

8905

TORNILLO REGULADOR UNIDIRECCIONAL PARA CILINDRO, REGULACIÓN MANUAL - *FLOW REGULATOR FOR CYLINDER. MANUAL REGULATION*

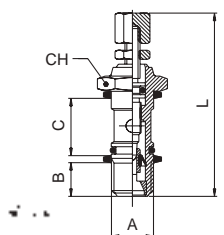

Código Code	A	B	C	Lmin	Lmax	CH	Conf. Pack.
089050001	M5	4	12.5	33	37.5	8	10
089050002	1/8	5.5	15	41	46.5	14	10
089050003	1/4	8.5	17	46.5	52.5	17	10
089050004	3/8	9	20	56.5	63.5	20	10
089050005	1/2	10	24	62	69.5	24	10

8910

TORNILLO REGULADOR UNIDIRECCIONAL PARA VÁLVULA, REGULACIÓN A DESTORNILLADOR - *FLOW REGULATOR FOR VALVE. SCREWDRIVER REGULATION*

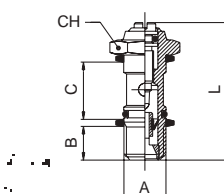

Código Code	A	B	C	L	CH	Conf. Pack.
089100001	M5	4	12.5	24	8	10
089100002	1/8	5.5	15	30.5	14	10
089100003	1/4	8.5	17	35.5	17	10
089100004	3/8	9	20	41	20	10
089100005	1/2	10	24	47	24	10

8915

TORNILLO REGULADOR UNIDIRECCIONAL PARA VÁLVULA, REGULACIÓN MANUAL - *FLOW REGULATOR FOR VALVE MANUAL REGULATION*

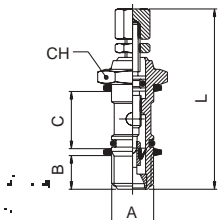

Código Code	A	B	C	Lmin	Lmax	CH	Conf. Pack.
089150001	M5	4	12.5	33	37.5	8	10
089150002	1/8	5.5	15	41	46.5	14	10
089150003	1/4	8.5	17	46.5	52.5	17	10
089150004	3/8	9	20	56.5	63.5	20	10
089150005	1/2	10	24	62	69.5	24	10

8920

TORNILLO REGULADOR BIDIRECCIONAL, REGULACIÓN A DESTORNILLADOR - *BI-DIRECTIONAL FLOW REGULATOR SCREWDRIVER REGULATION*

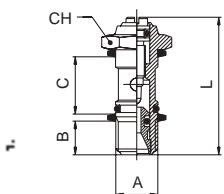

Código Code	A	B	C	L	CH	Conf. Pack.
089200001	M5	4	12.5	24	8	10
089200002	1/8	5.5	15	30.5	14	10
089200003	1/4	8.5	17	35.5	17	10
089200004	3/8	9	20	41	20	10
089200005	1/2	10	24	47	24	10

8925

TORNILLO REGULADOR BIDIRECCIONAL, REGULACIÓN MANUAL - *BI-DIRECTIONAL FLOW REGULATOR MANUAL REGULATION*

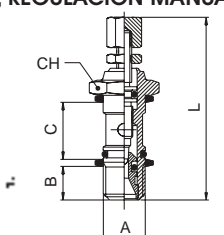

Código Code	A	B	C	Lmin	Lmax	CH	Conf. Pack.
089250001	M5	4	12.5	33	37.5	8	10
089250002	1/8	5.5	15	41	46.5	14	10
089250003	1/4	8.5	17	46.5	52.5	17	10
089250004	3/8	9	20	56.5	63.5	20	10
089250005	1/2	10	24	62	69.5	24	10

Reguladores de Caudal M5 / Flow Regulators valves M5 Size

En las tablas que siguen a continuación se especifican las medidas de los racores orientables Serie 1000 y Serie 50000 que pueden ser montados con los reguladores de M5. Las medidas del artículo 1500 han sido extrapoladas de la tabla del mismo artículo.

El artículo 50505 es un artículo especial producido a propósito para esta serie de reguladores de flujo de M5.

In the following tables specify the sizes of the single banjo bodies for 1000 50000 and 57000 series which can be assembled with regulators M5. The sizes the art. 1500 have been taken from the standard single banjo bodies table. Art. 50505 and 57505 are special single banjo bodies produced suitably for the of flow regulators M5 range.

Los reguladores de flujo de M5 deben ser acoplados con los racores orientables de M6.

The Flow Regulators size M5 must be assembled with orienting fittings size M6.

Durante la inserción del regulador en el anillo orientable prestar atención a no girar el labio de la junta.

When you assemble the flow regulator into the banjo body, please be careful not damage the seal.

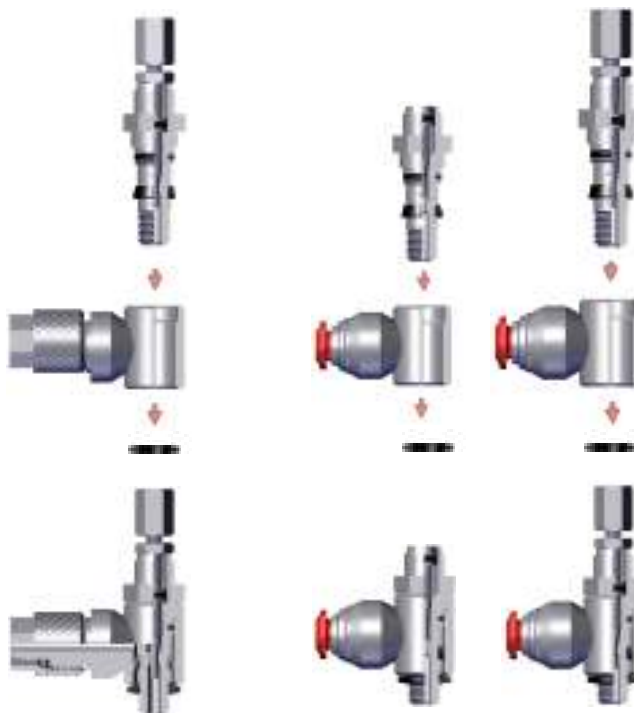

Serie 1000

Serie 50000 - 57000

1500

ANILLO ORIENTABLE SIMPLE (PARA REGULADOR DE CAUDAL M5) - SINGLE BANJO BODY (ADJUSTABLE RESTRICTOR VALVES M5)

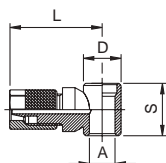

Código Code	Tubo Tube	A	D	S	L	Conf. Pack.
015000002	4/2.7	M6	9	12.5	21.5	10
015000007	6/4	M6	9	12.5	21.5	10

Este artículo se produce a propósito para los reguladores de flujo de M5.
This article has been produced suitably for the Adjustable Restrictor valves M5.

50505

ANILLO ORIENTABLE SIMPLE (PARA REGULADOR DE CAUDAL DE M5) - SINGLE BANJO BODY (ADJUSTABLE RESTRICTOR VALVES M5)

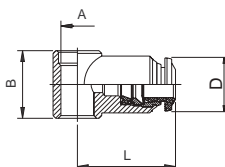

Código Code	Tubo Tube	A	B	L	D	Conf. Pack.
505050005	3	M6	12.5	19	10	10
505050001	4	M6	12.5	19	10	10
505050003	5	M6	12.5	20	12.5	10
505050004	6	M6	12.5	20.5	12.5	10

Este artículo se produce a propósito para los reguladores de flujo de M5.
This article has been produced suitably for the Adjustable Restrictor valves M5.

57505

ANILLO ORIENTABLE SIMPLE (PARA REGULADOR DE CAUDAL DE M5) - SINGLE BANJO BODY

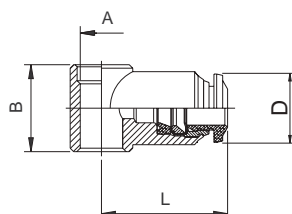

Código Code	Tubo Tube	A	B	L	D	Conf. Pack.
*575050001	4 (5/32)	M6	12.5	19	10	10
575050003	5	M6	12.5	20	12.5	10
575050004	6	M6	12.5	20.5	12.5	10

Este artículo se produce a propósito para los reguladores de flujo de M5.
This article has been produced suitably for the Adjustable Restrictor valves M5.

*Artículos en común con la serie 89505
*Item in common with series 89505

89505

ANILLO ORIENTABLE SIMPLE (PARA REGULATOR DE CAUDAL DE M5) - SINGLE BANJO BODY (ADJUSTABLE RESTRICTOR VALVES M5)

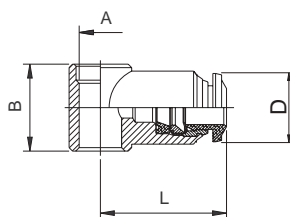

Código Code	Tubo Tube	A	B	L	D	Conf. Pack.
*5750500001	5/32 (4)	M6				10
8950500001	1/8	M6				10
8950500003	1/4	M6				10

Este artículo se produce a propósito para los reguladores de flujo de M5.
This article has been produced suitably for the Adjustable Restrictor valves M5.

*Artículos en común con la serie 57505
* Item in common with series 57505

1500

ANILLO ORIENTABLE SIMPLE - SINGLE BANJO BODY

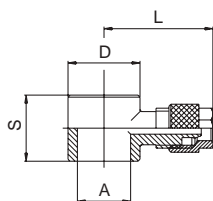

Código Code	Tubo Tube	A	D	S	L	Conf. Pack.
0150000003	4/2.7	1/8	14	15	23.3	10
0150000005	5/3	1/8	14	15	23.3	10
0150000008	6/4	1/8	14	15	23.3	10
0150000009	6/4	1/4	18	17	25.3	10
0150000010	6/4	3/8	21	20	26.8	10
0150000011	8/6	1/8	14	15	24.7	10
0150000012	8/6	1/4	18	17	27.6	10
0150000013	8/6	3/8	21	20	27.7	10
0150000014	8/6	1/2	26	24	31.2	10
0150000015	10/8	1/8	14	15	27.5	10
0150000016	10/8	1/4	18	17	29.5	10
0150000017	10/8	3/8	21	20	30.5	10
0150000018	10/8	1/2	26	24	34	10
0150000019	12/10	3/8	21	20	31.5	10
0150000020	12/10	1/2	26	24	35	10
0150000021	15/12.5	1/2	26	24	36.5	10

50500

ANILLO ORIENTABLE SIMPLE - SINGLE BANJO BODY



Código Code	Tubo Tube	A	B	L	CH	D	Conf. Pack.
5050000003	4	1/8	15	21	14	10	10
5050000014	5	1/8	15	21.5	14	12.5	10
5050000015	5	1/4	17	24.5	18	12.5	10
5050000004	6	1/8	15	22	14	12.5	10
5050000005	6	1/4	17	25	18	12.5	10
5050000006	8	1/8	15	24	14	14	10
5050000007	8	1/4	17	26	18	14	10
5050000008	8	3/8	20	28	21	14	10
5050000009	10	1/4	17	29	18	17	10
5050000010	10	3/8	20	30.5	21	17	10
5050000012	12	3/8	20	32.5	21	21.5	10
5050000021	12	1/2	24	35	25	21.5	10
5050000022	14	1/2	24	35.5	25	21.5	10

57500

ANILLO ORIENTABLE SIMPLE - SINGLE BANJO BODY



Código Code	Tubo Tube	A	B	L	CH	D	Conf. Pack.
5750000003	4	1/8	15	21	14	10	10
5750000014	5	1/8	15	21.5	14	12.5	10
5750000015	5	1/4	17	24.5	18	12.5	10
5750000004	6	1/8	15	22	14	12.5	10
5750000005	6	1/4	17	25	18	12.5	10
5750000006	8	1/8	15	24	14	14	10
5750000007	8	1/4	17	26	18	14	10
5750000008	8	3/8	20	28	21	14	10
5750000009	10	1/4	17	29	18	17	10
5750000010	10	3/8	20	30.5	21	17	10
5750000012	12	3/8	20	32.5	21	21.5	10
5750000021	12	1/2	24	35	25	21.5	10
5750000022	14	1/2	24	35.5	25	21.5	10

8953

REGULADOR UNIDIRECCIONAL PARA CILINDRO, REGULACIÓN A DESTORNILLADOR UNI-DIRECTIONAL FLOW REGULATOR FOR CILINDER SCREWDRIVER REGULATION

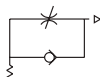
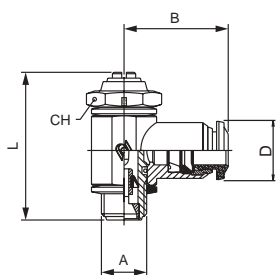

Código Code	Tubo Tube	A	B	L	CH	D	Conf. Pack.
0895300012	3	M5	19	24	8	10	10
0895300001	4	M5	19	24	8	10	10
0895300002	4	1/8	21	30.5	14	10	10
0895300007	5	M5	20	24	8	12.5	10
0895300008	5	1/8	21.5	30.5	14	12.5	10
0895300009	5	1/4	24.5	35.5	17	12.5	10
0895300010	6	M5	20.5	24	8	12.5	10
0895300003	6	1/8	22.5	30.5	14	12.5	10
0895300004	6	1/4	25	35.5	17	12.5	10
0895300005	8	1/8	24	30.5	14	14	10
0895300006	8	1/4	26	35.5	17	14	10
0895300017	8	3/8	28	35.5	20	14	10
0895300011	10	1/4	29	35.5	17	17	10
0895300013	10	3/8	30.5	35.5	20	17	10
0895300014	12	3/8	32.5	35.5	20	21.5	10
0895300015	12	1/2	35	35.5	24	21.5	10
0895300016	14	1/2	35.5	35.5	24	21.5	10

8958

REGULADOR UNIDIRECCIONAL PARA CILINDRO, REGULACIÓN MANUAL UNI-DIRECTIONAL FLOW REGULATOR FOR CILINDER MANUAL REGULATION

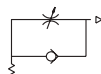
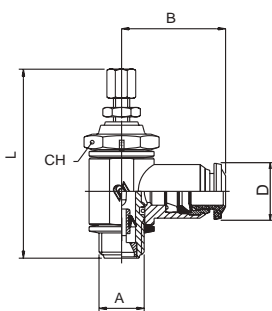

Código Code	Tubo Tube	A	B	Lmin	Lmax	CH	D	Conf. Pack.
0895800013	3	M5	19	33	37.5	8	10	10
0895800001	4	M5	19	33	37.5	8	10	10
0895800002	4	1/8	21	41	46.5	14	10	10
0895800011	5	M5	20	33	37.5	8	12.5	10
0895800008	5	1/8	21.5	41	46.5	14	12.5	10
0895800009	5	1/4	24.5	46.5	52.5	17	12.5	10
0895800012	6	M5	20.5	33	37.5	8	12.5	10
0895800003	6	1/8	22.5	41	46.5	14	12.5	10
0895800004	6	1/4	25	46.5	52.5	17	12.5	10
0895800005	8	1/8	24	41	46.5	14	14	10
0895800006	8	1/4	26	46.5	52.5	17	14	10
0895800007	8	3/8	28	56.5	63.5	20	14	10
0895800010	10	1/4	29	46.5	52.5	17	17	10
0895800014	10	3/8	30.5	56.5	63.5	20	17	10
0895800015	12	3/8	32.5	56.5	63.5	20	21.5	10
0895800016	12	1/2	35	62	69.5	24	21.5	10
0895800017	14	1/2	35.5	62	69.5	24	21.5	10

8963

REGULADOR UNIDIRECCIONAL PARA VÁLVULA, REGULACIÓN A DESTORNILLADOR UNI-DIRECTIONAL FLOW REGULATOR FOR VALVE SCREWDRIVER REGULATION

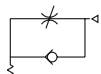
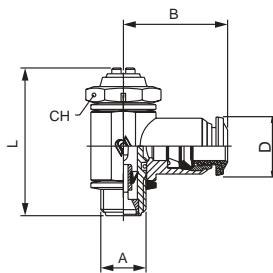

Código Code	Tubo Tube	A	B	L	CH	D	Conf. Pack.
0896300012	3	M5	19	24	8	10	10
0896300001	4	M5	19	24	8	10	10
0896300002	4	1/8	21	30.5	14	10	10
0896300007	5	M5	20	24	8	12.5	10
0896300008	5	1/8	21.5	30.5	14	12.5	10
0896300009	5	1/4	24.5	35.5	17	12.5	10
0896300010	6	M5	20.5	24	8	12.5	10
0896300003	6	1/8	22.5	30.5	14	12.5	10
0896300004	6	1/4	25	35.5	17	12.5	10
0896300005	8	1/8	24	30.5	14	14	10
0896300006	8	1/4	26	35.5	17	14	10
0896300011	8	3/8	28	35.5	20	14	10
0896300014	10	1/4	29	35.5	17	17	10
0896300013	10	3/8	30.5	35.5	20	17	10
0896300015	12	3/8	32.5	35.5	20	21.5	10
0896300016	12	1/2	35	35.5	24	21.5	10
0896300017	14	1/2	35.5	35.5	24	21.5	10

8968

REGULADOR UNIDIRECCIONAL PARA VÁLVULA, REGULACIÓN MANUAL UNI-DIRECTIONAL FLOW REGULATOR FOR VALVE MANUAL REGULATION

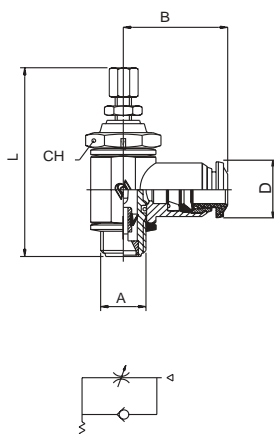

Código Code	Tubo Tube	A	B	Lmin	Lmax	CH	D	Conf. Pack.
089680009	3	M5	19	33	37.5	8	10	10
089680001	4	M5	19	33	37.5	8	10	10
089680002	4	1/8	21	41	46.5	14	10	10
089680011	5	M5	20	33	37.5	8	12.5	10
089680007	5	1/8	21.5	41	46.5	14	12.5	10
089680008	5	1/4	24.5	46.5	52.5	17	12.5	10
089680012	6	M5	20.5	33	37.5	8	12.5	10
089680003	6	1/8	22.5	41	46.5	14	12.5	10
089680004	6	1/4	25	46.5	52.5	17	12.5	10
089680005	8	1/8	24	41	46.5	14	14	10
089680006	8	1/4	26	46.5	52.5	17	14	10
089680013	8	3/8	28	56.5	63.5	20	14	10
089680014	10	1/4	29	46.5	52.5	17	17	10
089680015	10	3/8	30.5	56.5	63.5	20	17	10
089680016	12	3/8	32.5	56.5	63.5	20	21.5	10
089680017	12	1/2	35	62	69.5	24	21.5	10
089680018	14	1/2	35.5	62	69.5	24	21.5	10

8973

REGULADOR BIDIRECCIONAL, REGULACIÓN A DESTORNILLADOR BI-DIRECTIONAL FLOW REGULATOR SCREWDRIVER REGULATION

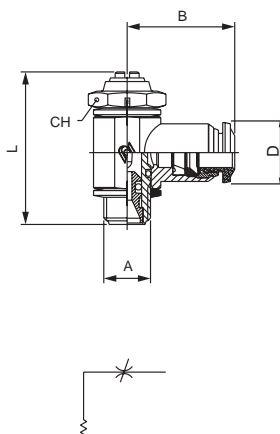

Código Code	Tubo Tube	A	B	L	CH	D	Conf. Pack.
089730012	3	M5	19	24	8	10	25
089730001	4	M5	19	24	8	10	25
089730002	4	1/8	21	30.5	14	10	25
089730007	5	M5	20	24	8	12.5	25
089730008	5	1/8	21.5	30.5	14	12.5	25
089730009	5	1/4	24.5	35.5	17	12.5	25
089730010	6	M5	20.5	24	8	12.5	25
089730003	6	1/8	22.5	30.5	14	12.5	25
089730004	6	1/4	25	35.5	17	12.5	25
089730005	8	1/8	24	30.5	14	14	25
089730006	8	1/4	26	35.5	17	14	25
089730013	8	3/8	28	35.5	20	14	25
089730014	10	1/4	29	35.5	17	17	25
089730015	10	3/8	30.5	35.5	20	17	25
089730016	12	3/8	32.5	35.5	20	21.5	25
089730017	12	1/2	35	35.5	24	21.5	25
089730018	14	1/2	35.5	35.5	24	21.5	25

8978

REGULADOR BIDIRECCIONAL, REGULACIÓN MANUAL BI-DIRECTIONAL FLOW REGULATOR MANUAL REGULATION

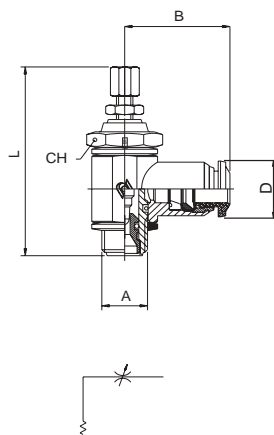

Código Code	Tubo Tube	A	B	Lmin	Lmax	CH	D	Conf. Pack.
089780007	3	M5	19	33	37.5	8	10	10
089780001	4	M5	19	33	37.5	8	10	10
089780002	4	1/8	21	41	46.5	14	10	10
089780011	5	M5	20	33	37.5	8	12.5	10
089780008	5	1/8	21.5	41	46.5	14	12.5	10
089780009	5	1/4	24.5	46.5	52.5	17	12.5	10
089780012	6	M5	20.5	33	37.5	8	12.5	10
089780003	6	1/8	22.5	41	46.5	14	12.5	10
089780004	6	1/4	25	46.5	52.5	17	12.5	10
089780005	8	1/8	24	41	46.5	14	14	10
089780006	8	1/4	26	46.5	52.5	17	14	10
089780010	8	3/8	28	56.5	63.5	20	14	10
089780013	10	1/4	29	46.5	52.5	17	17	10
089780014	10	3/8	30.5	56.5	63.5	20	17	10
089780015	12	3/8	32.5	56.5	63.5	20	21.5	10
089780016	12	1/2	35	62	69.5	24	21.5	10
089780017	14	1/2	35.5	62	69.5	24	21.5	10

8950

REGULADOR UNIDIRECCIONAL PARA CILINDRO, REGULACIÓN A DESTORNILLADOR UNI-DIRECTIONAL FLOW REGULATOR FOR CYLINDER SCREWDRIVER REGULATION

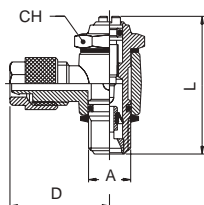

Código Code	Tubo Tube	A	D	L	CH	Conf. Pack.
089500001	4/2.7	M5	21.5	24	8	10
089500002	4/2.7	1/8	23.3	30.5	14	10
089500003	6/4	M5	21.5	24	8	10
089500004	6/4	1/8	23.3	30.5	14	10
089500005	6/4	1/4	25.3	35.5	17	10
089500006	8/6	1/8	24.7	30.5	14	10
089500007	8/6	1/4	27.6	35.5	17	10
089500015	8/6	3/8	27.7	41	20	10
089500008	10/8	1/4	29.5	35.5	17	10
089500011	10/8	3/8	30.5	41	20	10
089500012	12/10	3/8	31.5	41	20	10
089500013	12/10	1/2	35	47	24	10
089500014	15/12.5	1/2	36.5	47	24	10

8955

REGULADOR UNIDIRECCIONAL PARA CILINDRO, REGULACIÓN MANUAL UNI-DIRECTIONAL FLOW REGULATOR FOR CYLINDER MANUAL REGULATION

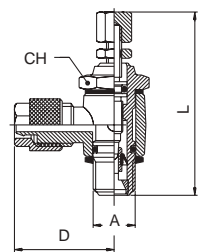

Código Code	Tubo Tube	A	D	Lmin	Lmax	CH	Conf. Pack.
089550001	4/2.7	M5	21.5	33	37.5	8	10
089550002	4/2.7	1/8	23.3	41	46.5	14	10
089550003	6/4	M5	21.5	33	37.5	8	10
089550004	6/4	1/8	23.3	41	46.5	14	10
089550005	6/4	1/4	25.3	46.5	52.5	17	10
089550006	8/6	1/8	24.7	41	46.5	14	10
089550007	8/6	1/4	27.6	46.5	52.5	17	10
089550015	8/6	3/8	27.7	56.5	63.5	20	10
089550008	10/8	1/4	29.5	46.5	52.5	17	10
089550011	10/8	3/8	30.5	56.5	63.5	20	10
089550012	12/10	3/8	31.5	56.5	63.5	20	10
089550013	12/10	1/2	35	62	69.5	24	10
089550014	15/12.5	1/2	36.5	62	69.5	24	10

8960

REGULADOR UNIDIRECCIONAL PARA VÁLVULA, REGULACIÓN A DESTORNILLADOR UNI-DIRECTIONAL FLOW REGULATOR FOR VALVE SCREWDRIVER REGULATION

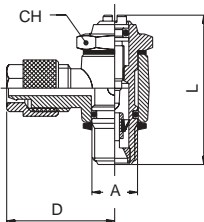

Código Code	Tubo Tube	A	D	L	CH	Conf. Pack.
089600001	4/2.7	M5	21.5	24	8	10
089600002	4/2.7	1/8	23.3	30.5	14	10
089600003	6/4	M5	21.5	24	8	10
089600004	6/4	1/8	23.3	30.5	14	10
089600005	6/4	1/4	25.3	35.5	17	10
089600006	8/6	1/8	24.7	30.5	14	10
089600007	8/6	1/4	27.6	35.5	17	10
089600015	8/6	3/8	27.7	41	20	10
089600008	10/8	1/4	29.5	35.5	17	10
089600011	10/8	3/8	30.5	41	20	10
089600012	12/10	3/8	31.5	41	20	10
089600013	12/10	1/2	35	47	24	10
089600014	15/12.5	1/2	36.5	47	24	10

8965

REGULADOR UNIDIRECCIONAL PARA VÁLVULA, REGULACIÓN MANUAL UNI-DIRECTIONAL FLOW REGULATOR FOR VALVE MANUAL REGULATION

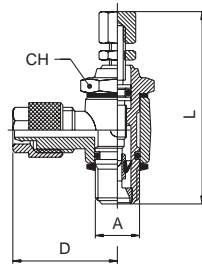

Código Code	Tubo Tube	A	D	Lmin	Lmax	CH	Conf. Pack.
0896500001	4/2.7	M5	21.5	33	37.5	8	10
0896500002	4/2.7	1/8	23.3	41	46.5	14	10
0896500003	6/4	M5	21.5	33	37.5	8	10
0896500004	6/4	1/8	23.3	41	46.5	14	10
0896500005	6/4	1/4	25.3	46.5	52.5	17	10
0896500006	8/6	1/8	24.7	41	46.5	14	10
0896500007	8/6	1/4	27.6	46.5	52.5	17	10
0896500015	8/6	3/8	27.7	56.5	63.5	20	10
0896500008	10/8	1/4	29.5	46.5	52.5	17	10
0896500011	10/8	3/8	30.5	56.5	63.5	20	10
0896500012	12/10	3/8	31.5	56.5	63.5	20	10
0896500013	12/10	1/2	35	62	69.5	24	10
0896500014	15/12.5	1/2	36.5	62	69.5	24	10

8970

REGULADOR BIDIRECCIONAL, REGULACIÓN A DESTORNILLADOR BI-DIRECTIONAL FLOW REGULATOR SCREWDRIVER REGULATION

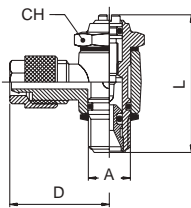

Código Code	Tubo Tube	A	D	L	CH	Conf. Pack.
0897000001	4/2.7	M5	21.5	24	8	10
0897000002	4/2.7	1/8	23.3	30.5	14	10
0897000003	6/4	M5	21.5	24	8	10
0897000004	6/4	1/8	23.3	30.5	14	10
0897000005	6/4	1/4	25.3	35.5	17	10
0897000006	8/6	1/8	24.7	30.5	14	10
0897000007	8/6	1/4	27.6	35.5	17	10
0897000015	8/6	3/8	27.7	41	20	10
0897000008	10/8	1/4	29.5	35.5	17	10
0897000011	10/8	3/8	30.5	41	20	10
0897000012	12/10	3/8	31.5	41	20	10
0897000013	12/10	1/2	35	47	24	10
0897000014	15/12.5	1/2	36.5	47	24	10

8975

REGULADOR BIDIRECCIONAL, REGULACIÓN MANUAL BI-DIRECTIONAL FLOW REGULATOR MANUAL REGULATION

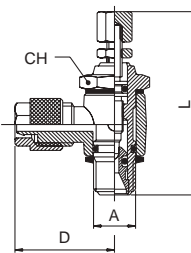

Código Code	Tubo Tube	A	D	Lmin	Lmax	CH	Conf. Pack.
0897500001	4/2.7	M5	21.5	33	37.5	8	10
0897500002	4/2.7	1/8	23.3	41	46.5	14	10
0897500003	6/4	M5	21.5	33	37.5	8	10
0897500004	6/4	1/8	23.3	41	46.5	14	10
0897500005	6/4	1/4	25.3	46.5	52.5	17	10
0897500006	8/6	1/8	24.7	41	46.5	14	10
0897500007	8/6	1/4	27.6	46.5	52.5	17	10
0897500015	8/6	3/8	27.7	56.5	63.5	20	10
0897500008	10/8	1/4	29.5	46.5	52.5	17	10
0897500011	10/8	3/8	30.5	56.5	63.5	20	10
0897500012	12/10	3/8	31.5	56.5	63.5	20	10
0897500013	12/10	1/2	35	62	69.5	24	10
0897500014	15/12.5	1/2	36.5	62	69.5	24	10

8952

REGULADOR UNIDIRECCIONAL PARA CILINDRO, REGULACIÓN A DESTORNILLADOR UNI-DIRECTIONAL FLOW REGULATOR FOR CILINDER SCREWDRIVER REGULATION

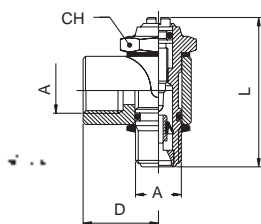

Código Code	A	D	L	CH	Conf. Pack.
089520001	1/8	16.5	30.5	14	10
089520002	1/4	22	35.5	17	10
089520003	3/8	26	35.5	20	10

8957

REGULADOR UNIDIRECCIONAL PARA CILINDRO, REGULACIÓN MANUAL UNI-DIRECTIONAL FLOW REGULATOR FOR CILINDER MANUAL REGULATION

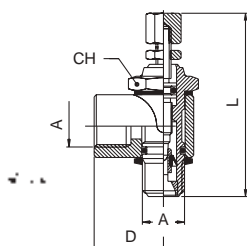

Código Code	A	D	Lmin	Lmax	CH	Conf. Pack.
089570001	1/8	16.5	41	46.5	14	10
089570002	1/4	22	46.5	52.5	17	10
089570003	3/8	26	56.5	63.5	17	10

8962

REGULADOR UNIDIRECCIONAL PARA VÁLVULA, REGULACIÓN A DESTORNILLADOR UNI-DIRECTIONAL FLOW REGULATOR FOR VALVE SCREWDRIVER REGULATION

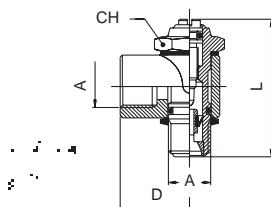

Código Code	A	D	L	CH	Conf. Pack.
089620001	1/8	16.5	30.5	14	10
089620002	1/4	22	35.5	17	10
089620003	3/8	26	35.5	20	10

8967

REGULADOR UNIDIRECCIONAL PARA VÁLVULA, REGULACIÓN MANUAL UNI-DIRECTIONAL FLOW REGULATOR FOR VALVE MANUAL REGULATION

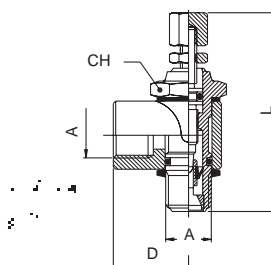

Código Code	A	D	Lmin	Lmax	CH	Conf. Pack.
089670001	1/8	16.5	41	46.5	14	10
089670002	1/4	22	46.5	52.5	17	10
089670003	3/8	26	56.5	63.5	17	10

8972

REGULADOR BIDIRECCIONAL, REGULACIÓN A DESTORNILLADOR BI-DIRECTIONAL FLOW REGULATOR SCREWDRIVER REGULATION

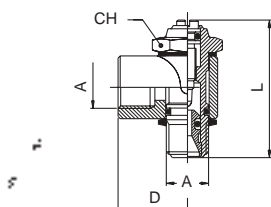

Código Code	A	D	L	CH	Conf. Pack.
089720001	1/8	16.5	30.5	14	10
089720002	1/4	22	35.5	17	10
089720003	3/8	26	35.5	20	10

8977

REGULADOR BIDIRECCIONAL, REGULACIÓN MANUAL BI-DIRECTIONAL FLOW REGULATOR MANUAL REGULATION

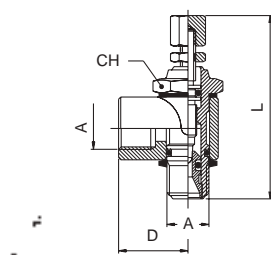

Código Code	A	D	Lmin	Lmax	CH	Conf. Pack.
089770001	1/8	16.5	41	46.5	14	10
089770002	1/4	22	46.5	52.5	17	10
089770003	3/8	26	56.5	63.5	17	10

CARACTERÍSTICAS DE FLUJO
REGULADORES DE CAUDAL
UNIDIRECCIONALES Y
BIDIRECCIONALES
FLOW CHARACTERISTICS
ADJUSTABLE RESTRICTOR
VALVES UNI-DIRECTIONALS
AND BI-DIRECTIONALS

Encontramos en esta página las características de flujo de los reguladores para una correcta elección de la medida que más se adapte a cada uso específico.

In this page you can find the flow characteristics of the regulators, which will help you to chose the most suitable size to satisfy every specific use.

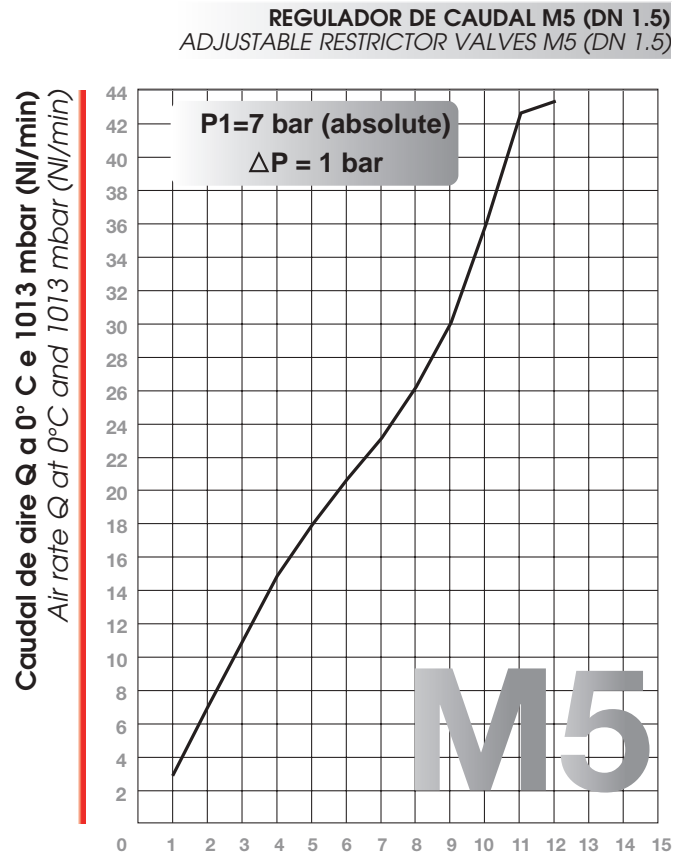

Número de giros tornillo regulador
Number of turns of the adjusting needle

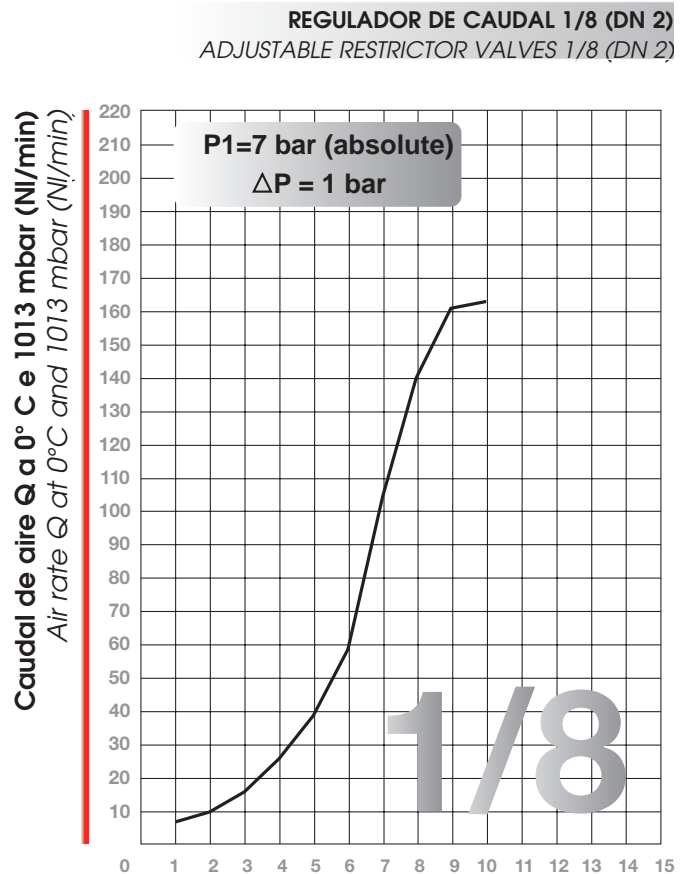

Número de giros tornillo regulador
Number of turns of the adjusting needle

REGULADOR DE CAUDAL 1/4 (DN 3.5)
ADJUSTABLE RESTRICTOR VALVES 1/4 (DN 3.5)

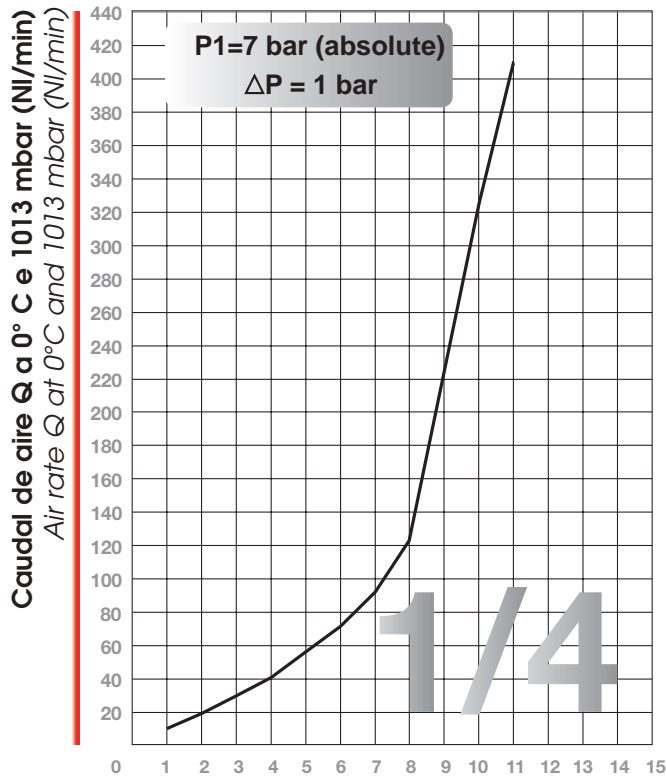

Número de giros tornillo regulador
Number of turns of the adjusting needle

REGULADOR DE CAUDAL 3/8 (DN 6)
ADJUSTABLE RESTRICTOR VALVES 3/8 (DN 6)

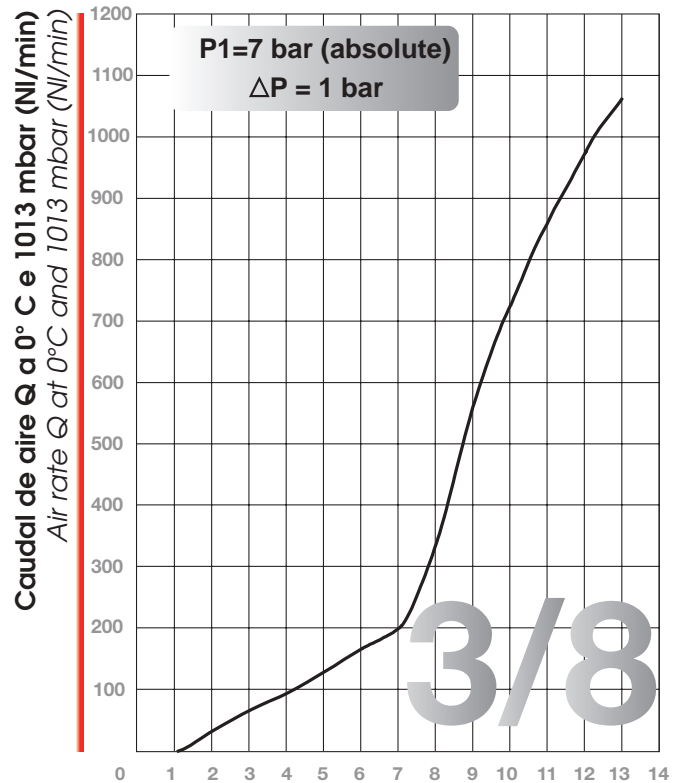

Número de giros tornillo regulador
Number of turns of the adjusting needle

REGULADOR DE CAUDAL 1/2 (DN 6)
ADJUSTABLE RESTRICTOR VALVES 1/2 (DN 6)

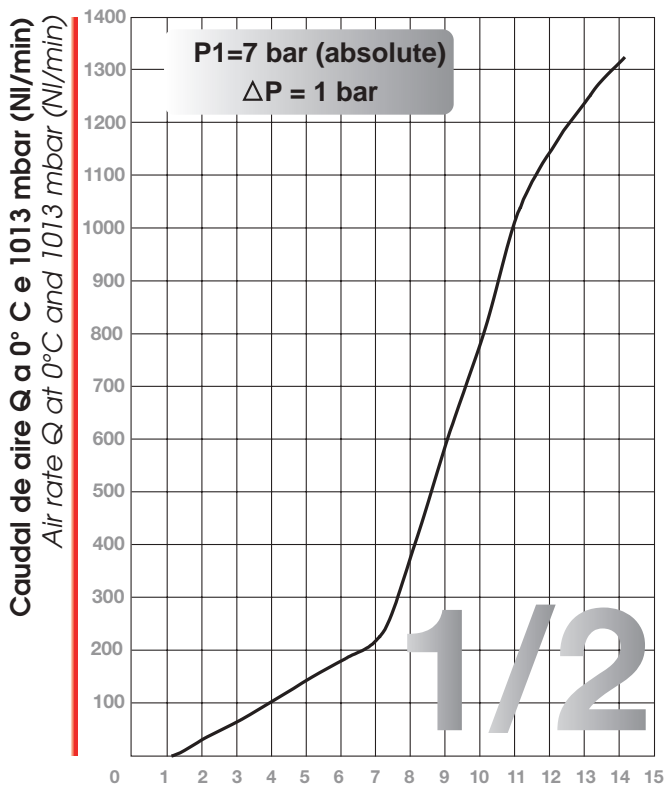

Número de giros tornillo regulador
Number of turns of the adjusting needle

Reguladores de Flujo en Línea / In Line Adjustable Restrictor valves

Características Técnicas / Technical Characteristics

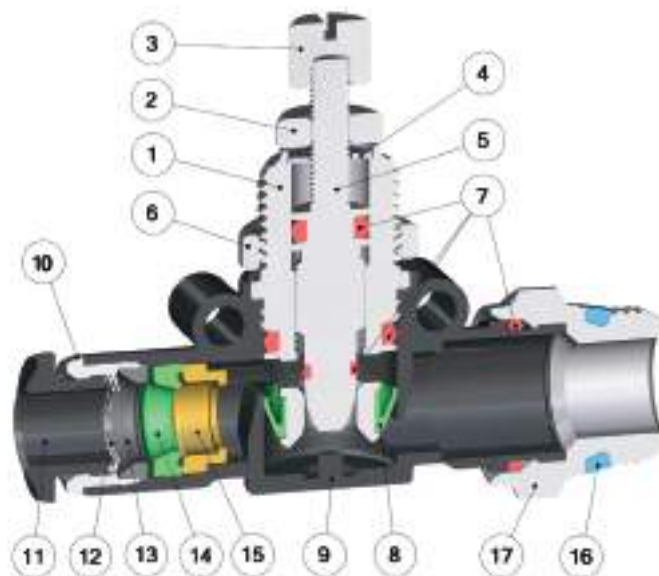

Materiales y Componentes / Component Parts and Materials

- | | |
|--|--|
| 1 Manguito de unión en latón niquelado | 5 Nickel-Plated Brass Nipple |
| 2 Tuerca de bloqueo en latón niquelado | 2 Nickel-Plated Brass Locking nut |
| 3 Pomo de mando en latón niquelado | 3 Nickel-Plated Brass Adjusting Knob |
| 4 Arandela en acero AISI 304 | 4 Steel AISI 304 Washer |
| 5 Tornillo de regulación en latón niquelado | 5 Nickel-Plated Brass Adjusting needle |
| 6 Tuerca en latón niquelado | 6 Nickel-plated brass sleeve |
| 7 Junta tórica O-Ring en NBR | 7 NBR O-Ring seal |
| 8 Junta de labio en NBR | 8 NBR Lip seal |
| 9 Cuerpo en tecnopolímero | 9 Technopolymeric Body |
| 10 Cápsula en latón niquelado | 10 Nickel-Plated Brass Capsule |
| 11 Anillo de extracción tubo en resina acetálica | 11 Acetalic resin Collet |
| 12 Pinza de sujeción en acero AISI 301 | 12 Steel AISI 301 Clamping Washer |
| 13 Anillo de seguridad en tecnopolímero | 13 Technopolymeric safety Ring |
| 14 Junta de labio en NBR | 14 NBR Lip seal |
| 15 Soporte guía tubo en latón | 15 Brass Tube-guide Support |
| 16 Junta rosca en NBR | 16 NBR Thread Packing |
| 17 Base en latón niquelado | 17 Nickel-Plated Brass Base |

Presiones / Pressures

Presión mínima / Minimum pressure: **1 bar (0.1 MPa)**
 Presión máxima / Maximum pressure: **10 bar (1 MPa)**

Temperaturas / Temperatures

Temperatura mínima / Minimum temperature: **-20 °C**
 Temperatura máxima / Maximum temperature: **+80 °C**

Roscas / Threads

Gas cónica "short" / "Short" Tapered thread.
 Métrica conforme ISO R/262 / Metric in conformity with ISO R/262.

Tubos de conexión / Connection Tubes

Tubos en material plástico:
 PA6, PA11, PA 12, Polietileno, *Poliuretano;etc.
 *Para tubos de poliuretano se aconseja una dureza de 98 shore.
 Plastic tubes:
 PA6, PA11, PA12, Polyethylene, *Polyurethane, ecc.
 *For Polyurethane hoses it is required a minimum hardness of 98 shore.

Fluidos compatibles / Fluids

Aire comprimido / Compressed air.

Le Principali Caratteristiche / The Most Important Characteristics

La presencia de una tórica O-ring en el tornillo, garantiza una completa estanqueidad del regulador.
The O-ring on the needle, allows the complete, sealing of the regulator.

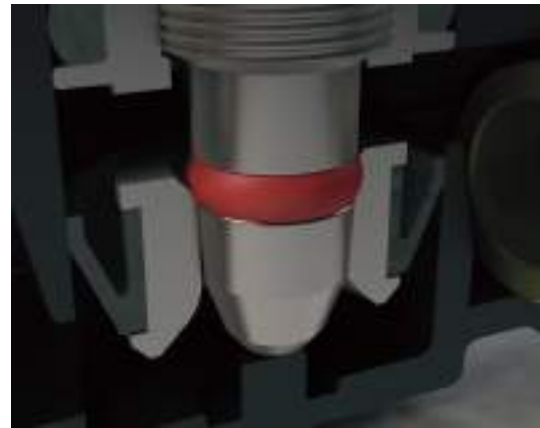

El montaje a panel, es posible mediante el manguito roscado y la correspondiente tuerca
Wall mounting, possible through the nipple and threaded ring nut.

Está previsto el montaje a pared, mediante tornillos de M3 introducidos en la correspondiente sede.
It provided for wall mounting, with M3 screws inserted into the appropriate locations.



55940

REGULADOR EN LINEA UNIDIRECCIONAL TUBO-TUBO
TUBE IN-LINE NEEDLE VALVE (UNIDIRECTIONAL FLOW)

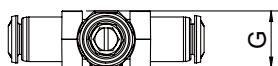
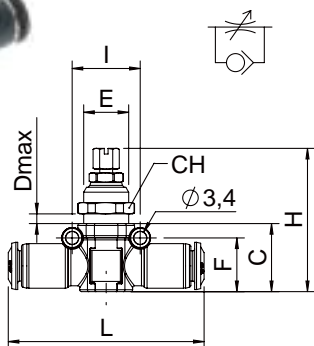

Código Code	Tubo Tube	C	D	E	F	G	H	I	L	CH	Conf. Pack.
5594000004	4	18	4	M12x1	14.5	15	37.5÷43.5	18	52	14	10
5594000001	6	18	6	M12x1	14.5	15	37.5÷43.5	18	52	14	10
5594000002	8	20	6.5	M14x1	16.5	17	39.5÷45.5	20	58	16	10
5594000003	10	23.5	8	M16x1	19.5	19	47.5÷53.5	22.5	67	18	10

55945

REGULADOR EN LINEA UNIDIRECCIONAL PARA CILINDRO MACHO SHORT-TUBO
MALE SHORT-TUBE IN-LINE FLOW CONTROL (CONTROLLED FLOW OUT)

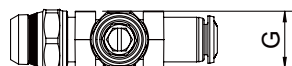
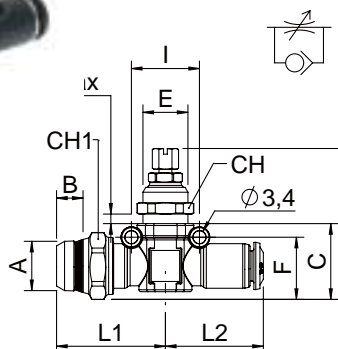

Código Code	Tubo Tube	A	B	C	D	E	F	G	H	I	L1	L2	CH	CH1	Conf. Pack.
5594500007	1/8 4	5.5	20	6	M12x1	16.5	15	39.5÷45.5	18	28.5	26	14	16	10	
5594500001	1/8 6	5.5	20	6	M12x1	16.5	15	39.5÷45.5	18	28.5	26	14	16	10	
5594500002	1/4 6	7	20	6	M12x1	16.5	15	39.5÷45.5	18	28.5	26	14	16	10	
5594500003	1/4 8	7	23	6.5	M14x1	16.5	17	42.5÷48.5	20	33.5	29	16	20	10	
5594500004	3/8 8	7.5	23	6.5	M14x1	16.5	17	42.5÷48.5	20	33.5	29	16	20	10	
5594500005	3/8 10	7.5	24.5	8	M16x1	20.5	19	42.5÷54	22.5	34.5	33.5	18	20	10	
5594500006	1/2 10	9	25	8	M16x1	21	19	42.5÷54.5	22.5	34.5	33.5	18	21	10	

55950

REGULADOR EN LINEA UNIDIRECCIONAL PARA VÁLVULA TUBO- MACHO SHORT
MALE SHORT-TUBE IN-LINE FLOW CONTROL (CONTROLLED FLOW IN)

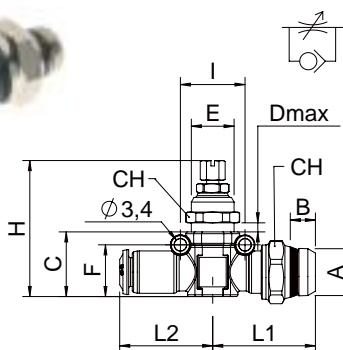

Código Code	Tubo Tube	A	B	C	D	E	F	G	H	I	L1	L2	CH	CH1	Conf. Pack.
5595000007	1/8 4	5.5	20	6	M12x1	16.5	15	39.5÷45.5	18	29	26	14	16	10	
5595000001	1/8 6	5.5	20	6	M12x1	16.5	15	39.5÷45.5	18	29	26	14	16	10	
5595000002	1/4 6	7	20	6	M12x1	16.5	15	39.5÷45.5	18	29	26	14	16	10	
5595000003	1/4 8	7	23	6.5	M14x1	16.5	17	42.5÷48.5	20	33.5	29	16	20	10	
5595000004	3/8 8	7.5	23	6.5	M14x1	16.5	17	42.5÷48.5	20	33.5	29	16	20	10	
5595000005	3/8 10	7.5	24.5	8	M16x1	20.5	19	42.5÷54	22.5	34.5	33.5	18	20	10	
5595000006	1/2 10	9	25	8	M16x1	21	19	42.5÷54.5	22.5	34.5	33.5	18	21	10	

55955

REGULADOR EN LINEA BIDIRECCIONAL TUBO-TUBO TUBE IN-LINE NEEDLE VALVE (BIDIRECTIONAL FLOW)

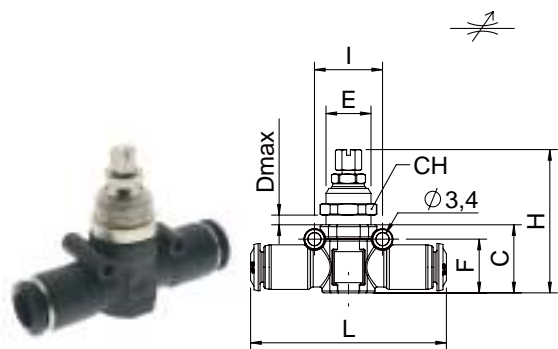

Código Code	Tubo Tube	C	D	E	F	G	H	I	L	CH	Conf. Pack.
5595500004	4	18	6	M12x1	14.5	15	37.5+43.5	18	52	14	10
5595500001	6	18	6	M12x1	14.5	15	37.5+43.5	18	52	14	10
5595500002	8	20	6.5	M14x1	16.5	17	39.5+45.5	20	58	16	10
5595500003	10	23.5	8	M16x1	19.5	19	47.5+53.5	22.5	67	18	10



55960

REGULADOR EN LINEA BIDIRECCIONAL MACHO SHORT-TUBO MALE SHORT-TUBE IN-LINE FLOW CONTROL (BIDIRECTIONAL FLOW)

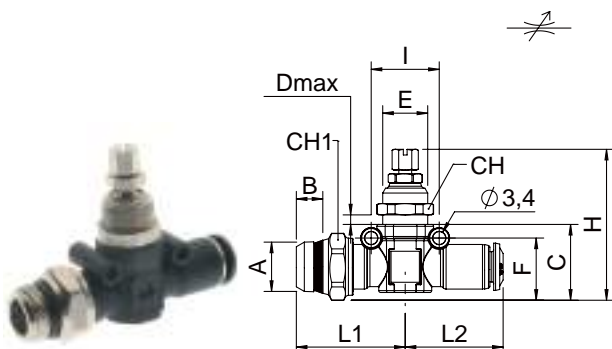

Código Code	Tubo Tube	A	B	C	D	E	F	G	H	I	L1	L2	CH	CH1	Conf. Pack.
5596000007	1/8 4	5.5	20	6	M12x1	16.5	15	39.5+45.5	18	28.5	26	14	16	10	
5596000001	1/8 6	5.5	20	6	M12x1	16.5	15	39.5+45.5	18	28.5	26	14	16	10	
5596000002	1/4 6	7	20	6	M12x1	16.5	15	39.5+45.5	18	28.5	26	14	16	10	
5596000003	1/4 8	7	23	6.5	M14x1	16.5	17	42.5+48.5	20	33.5	29	16	20	10	
5596000004	3/8 8	7.5	23	6.5	M14x1	16.5	17	42.5+48.5	20	33.5	29	16	20	10	
5596000005	3/8 10	7.5	24.5	8	M16x1	20.5	19	42.5+54	22.5	34.5	33.5	18	20	10	
5596000006	1/2 10	9	25	8	M16x1	21	19	42.5+54.5	22.5	34.5	33.5	18	21	10	

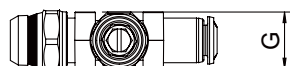

Reguladores de Flujo Unidireccionales / Uni-directional Flow Regulator

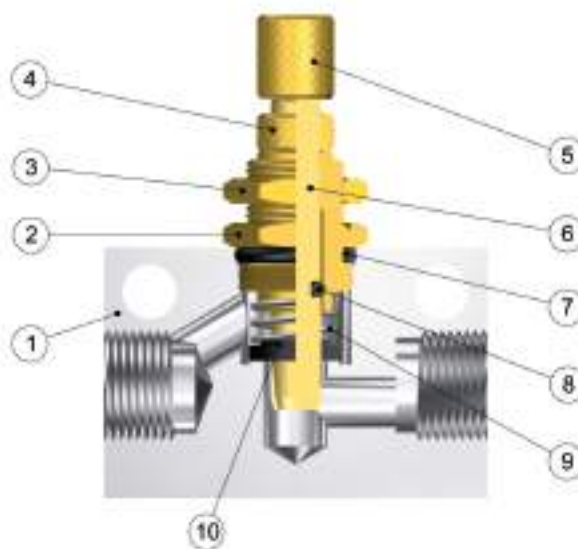

Materiales y Componentes / Component Parts and Materials

- | | |
|--|----------------------------------|
| 1 Cuerpo en aluminio anodizado | 1 Anodized aluminium Body |
| 2 Unión en latón | 2 Brass Nipple |
| 3 Tuerca de fijación en latón | 3 Brass Locking nut |
| 4 Tuerca en latón | 4 Brass Nut |
| 5 Pomo en latón | 5 Brass Adjusting Knob |
| 6 Tornillo regulador en latón | 6 Brass Adjusting needle |
| 7 Junta tórica O-Ring unión en NBR 70 | 7 NBR 70 O-Ring Nipple |
| 8 Junta tórica O-Ring tornillo en NBR 70 | 8 NBR 70 O-Ring Adjusting needle |
| 9 Muelle en acero | 9 Steel Spring |
| 10 Junta flotante | 10 Seal floating washer |

Presiones / Pressures

Presión absoluta entrada: 7 bar
Inlet pressure: 7 bar
Presión absoluta salida: presión atmosférica
Outlet pressure: atmosphere pressure

CARACTERÍSTICAS DE FLUJO REGULADORES DE CAUDAL UNIDIRECCIONALES FLOW CHARACTERISTICS ADJUSTABLE RESTRICTOR VALVES UNI-DIRECTIONALS

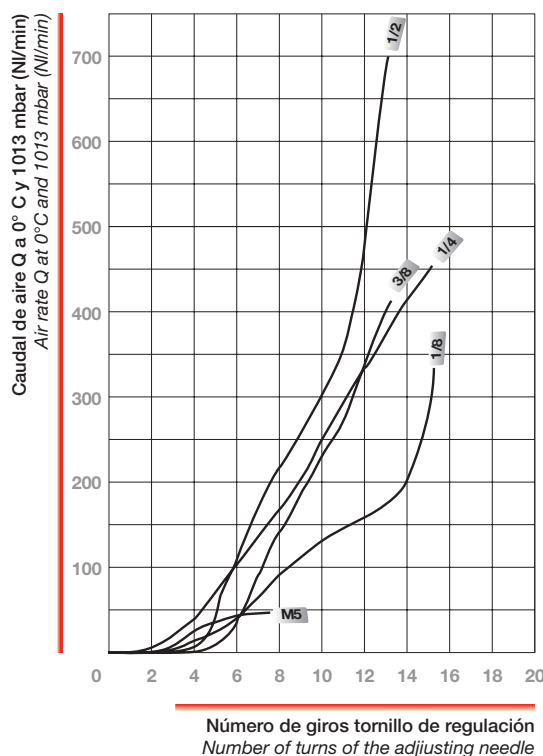

8850

REGULADOR DE FLUJO UNIDIRECCIONAL
UNI-DIRECTIONAL FLOW REGULATOR

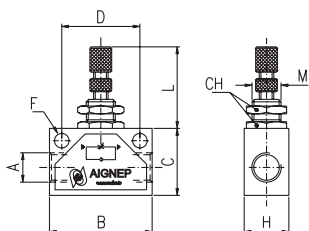

Código Code	A	B	C	H	D	F	L	M	CH	Conf. Pack.
0885000001	M5	25	15	12	18	4.5	20-27	M10x0.75	12	25
0885000002	1/8	35	22	18	24.7	4.5	26-36	M12x0.75	15	25
0885000003	1/4	46	30	20	35	6.5	26-36	M12x0.75	15	25
0885000004	3/8	50	30	25	35	6.5	32-42	M18x1.5	22	10
0885000005	1/2	60	40	25	44	6.5	32-44	M18x1.5	22	10

Reguladores de Flujo Bidireccionales / Bi-directional Flow Regulator

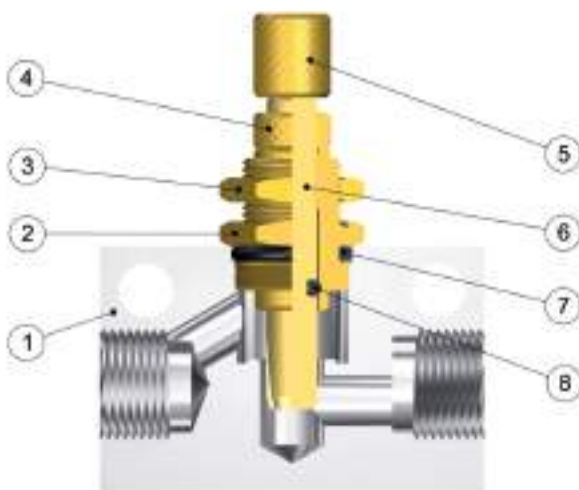

Materiales y Componentes / Component Parts and Materials

- | | |
|--|----------------------------------|
| 1 Cuerpo en aluminio anodizado | 1 Anodized aluminium Body |
| 2 Unión en latón | 2 Brass Nipple |
| 3 Tuerca de fijación en latón | 3 Brass Locking nut |
| 4 Tuerca en latón | 4 Brass Nut |
| 5 Pomo en latón | 5 Brass Adjusting Knob |
| 6 Tornillo regulador en latón | 6 Brass Adjusting needle |
| 7 Junta tórica O-Ring unión en NBR 70 | 7 NBR 70 O-Ring Nipple |
| 8 Junta tórica O-Ring tornillo en NBR 70 | 8 NBR 70 O-Ring Adjusting needle |

Presiones / Pressures

Presión absoluta entrada: 7 bar
Inlet pressure: 7 bar
Presión absoluta salida: presión atmosférica
Outlet pressure: atmosphere pressure

8860

REGULADOR DE FLUJO BIDIRECCIONAL
BI-DIRECTIONAL FLOW REGULATOR

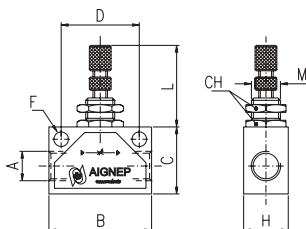

Código Code	A	B	C	H	D	F	L	M	CH	Conf. Pack.
0886000001	M5	25	15	12	18	4.5	20-27	M10x0.75	12	25
0886000002	1/8	35	22	18	24.7	4.5	27-34	M12x0.75	15	25
0886000003	1/4	46	30	20	35	6.5	27-34	M12x0.75	15	25
0886000004	3/8	50	30	25	35	6.5	32-43	M18x1.5	22	10
0886000005	1/2	60	40	25	44	6.5	32-43	M18x1.5	22	10

CARACTERÍSTICAS DE FLUJO REGULADORES DE CAUDAL BIDIRECCIONALES FLOW CHARACTERISTICS ADJUSTABLE RESTRICTOR VALVES BI-DIRECTIONALS

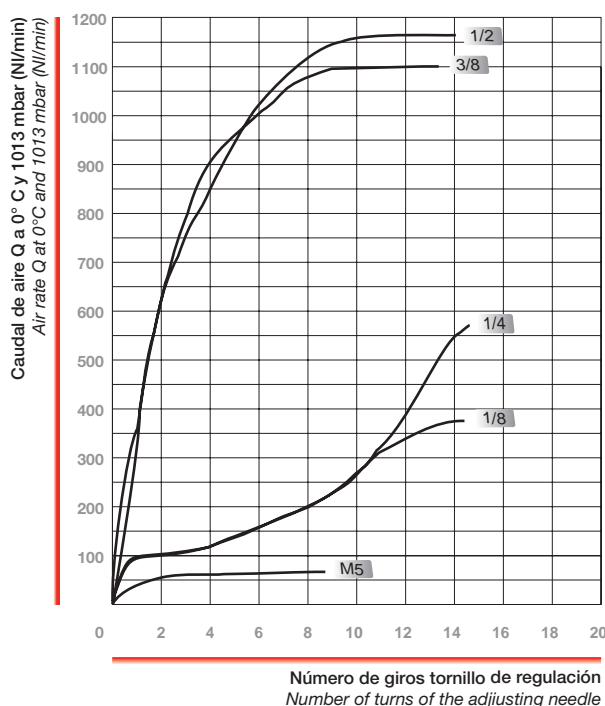

Válvula de Escape Rápido / Quick Exhaust Valve

En la norma UNI ISO 5598 este artículo viene así definido: "Válvula que la salida de la misma viene inmediatamente abierta a escape cada vez que cae la presión del aire a la entrada." El aire proveniente de la instalación entra por P desplaza la membrana excluyendo el escape R y va a la salida A (Fig. 1). En el momento en que no hay presión a la entrada P, el aire que se encuentra en la salida por diferencia de presión desplaza la membrana excluyendo P y sale por el escape R (Fig. 2). Estas válvulas permiten una mayor rapidez de escape agilizando los ciclos de trabajo. A la salida R es siempre conveniente montar un silenciador, o también con oportunas conexiones se puede reutilizar el flujo para otras señales o utilizaciones.

According to the definition of the UNI standards ref. UNI-ISO 5598 this valve is considered: "Valve which immediately opens its outlet to exhaust, whenever the pressure of the air decreases at the inlet." The air arrives from the system and enters at "P", it moves the pad (Part. N. 3) sealing "R" and bending the pad edges, it travels to "A" (Fig. N.1). When it miss the pressure in "P", the air presents into the system due to the difference of pressure, it moves the pad sealing "P" and it clears through outlet "R" (Fig N.2). This allows a speedy and a better exhaust and also it speeds up the work cycles. At the outlet "R" it is advised to assembly a silencer or if necessary use the flow for further signals or uses.

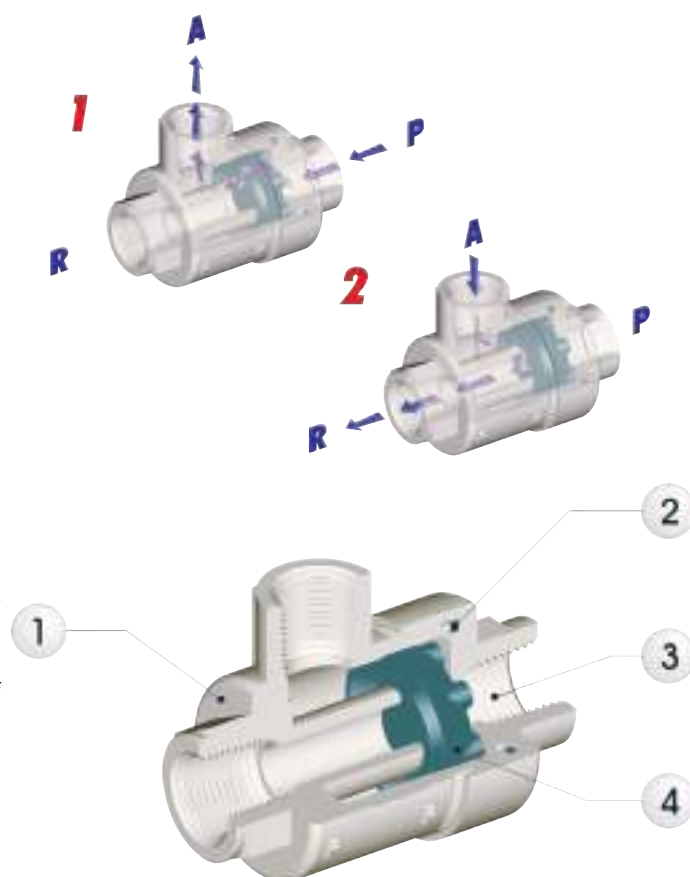

Materiales y Componentes / Component Parts and Materials

- | | |
|-------------------------------------|---------------------------------|
| 1 Cuerpo en latón niquelado | 1 Nickel-plated Brass Body |
| 2 Junta tórica O-Ring en Nylon PA66 | 2 PA66 O-RING Seals |
| 3 Tapa en latón niquelado | 3 Nickel-plated Brass Cover cap |
| 4 Membrana en NBR 70 | 4 NBR 70 Pad |

Presiones / Pressures

Presión mínima / Minimum pressure: **0.3 bar (0.03 MPa)**
 Presión máxima / Maximum pressure: **10 bar (1 MPa)**

Temperaturas / Temperatures

Temperatura mínima / Minimum temperature: **-20 °C**
 Temperatura máxima / Maximum temperature: **+80 °C**

Roscas / Threads

Gas cilíndrica conforme ISO 228 / Parallel gas in conformity with ISO 228.

Tubos de conexión / Connection Tubes

Racores varios para instalaciones neumáticas.
 Tubos metálicos en general.

Various types of fittings used on the pneumatic systems and metallic threaded tubes.

Fluidos compatibles / Fluids

Aire comprimido / Compressed air.

ATENCIÓN!

EL ESCAPE A ATMÓSFERA EXCLUYE EL USO DE LA VÁLVULA CON GASES TÓXICOS, CORROSIVOS O INFLAMABLES

ATTENTION!

THE FREE EXHAUST TO ATMOSPHERE DO NOT ALLOW TO USE THE VALVE WITH TOXICS, CORROSIVES AND INFLAMMABLES GAS.

6050

VÁLVULA DE ESCAPE RÁPIDO - QUICK EXHAUST VALVE

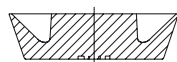
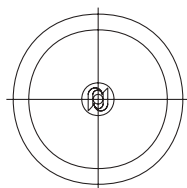

Código Code	A	B	L1	L2	CH	Conf. Pack.
0605000001	M5	4	25	10	17	25
0605000002	1/8	8.5	42	19.5	15	25
0605000003	1/4	11	54	25	19	10
0605000004	3/8	12	60.5	26.5	22	10
0605000005	1/2	15	72	32	26	10
0605000006	3/4	18.5	88	37	32	5
0605000007	1"	19	109	48	46	1

6052

MEMBRANA PARA VÁLVULA DE ESCAPE RÁPIDO EN NBR - PAD FOR QUICK EXHAUST VALVE MADE IN NBR

Código Code	Medida Size	Conf. Pack.
060520029B500	M5	25
0605200290200	1/8	25
0605200290300	1/4	25
0605200290400	3/8	10
0605200290500	1/2	10
0605200290700	3/4	5
0605200290900	1"	5

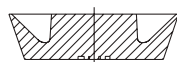
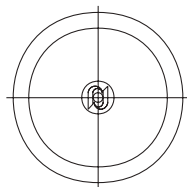
6052

MEMBRANA PARA VÁLVULA DE ESCAPE RÁPIDO EN POLIURETANO - PAD FOR QUICK EXHAUST VALVE MADE IN POLYURETHANE

Código Code	Medida Size	Conf. Pack.
0605200350200	1/8*	25
0605200350300	1/4*	25
0605200350500	1/2*	10
0605200350700	3/4*	5

6053

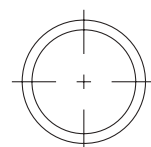
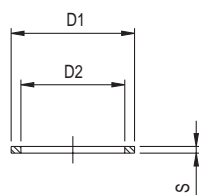
JUNTA TAPA - CAP SEAL

Código Code	Medida Size	D1	D2	S	Conf. Pack.
060530025B500	M5	15.8	13	1	25
0605300250200	1/8	24	20.2	1.3	25
0605300250300	1/4	29	25.4	1.5	25
0605300250400	3/8	33.5	28	1.5	10
0605300250500	1/2	38.8	34.5	1.5	10
0605300250700	3/4	43	38	1.5	5
0605300250900	1"	68.5	60.5	3.4	5

Válvulas de corredera / Slide Valve

Las válvulas de corredera se pueden considerar válvulas de paso ON-OFF con la variante que en la posición OFF dejan fluir el aire de la utilización al ambiente, descargando la presión del circuito. En la posición ON el aire proveniente del circuito pasa a la utilización a través de la conexión de los taladros radiales del eje de la válvula. Desplazando la válvula en posición OFF se cierra la conexión entre circuito y utilización, y el aire que se encuentra en la utilización fluye automáticamente al ambiente por diferencia de presión.

The slide valve can be considered a reversing valves ON-OFF with the variant that in the closed position it allows the used air to flow out to atmosphere. More detailed: in the opened position the air which comes from the system directs itself towards the circuit across the connection of the radial holes on the stem of the valve. Throwing the sleeve in the closed position You leave out the connection of the radial holes and the air which is still in the circuit due to the difference of pressure with the atmosphere, flows out automatically.

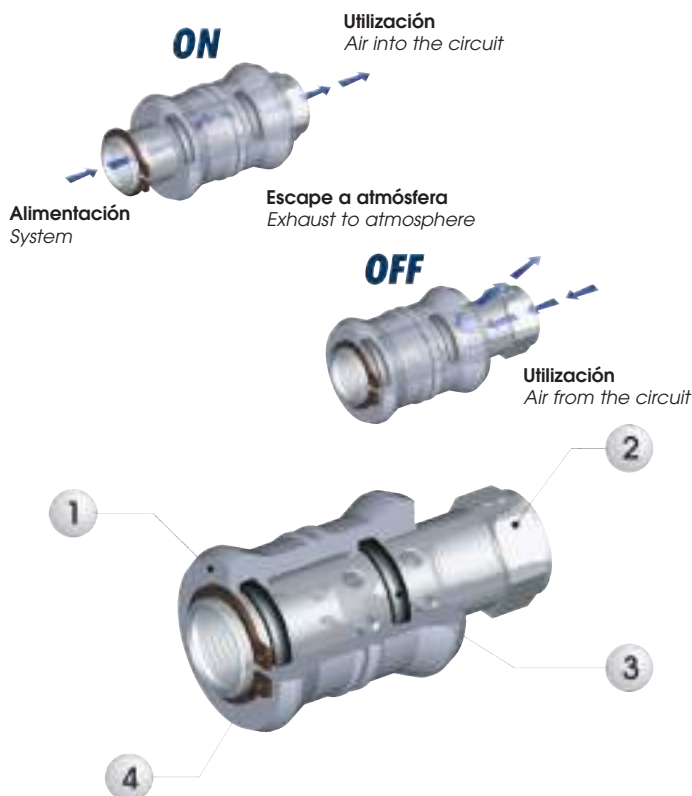

Materiales y Componentes / Component Parts and Materials

- | | |
|-----------------------------------|-----------------------------------|
| 1 Corredera en aluminio anodizado | 1 Grey anodized Aluminium Sleeve |
| 2 Eje en latón cromado | 2 Chrome-Nickel plated Brass Stem |
| 3 Junta tórica O-Ring en NBR 70 | 3 NBR 70 O-RING Seals |
| 4 Seeger en acero | 4 Steel Seeger |

Presiones / Pressures

Presión mínima / Minimum pressure: **0.3 bar (0.03 MPa)**
 Presión máxima / Maximum pressure: **10 bar (1 MPa)**

Roscas / Threads

Gas cilíndrica conforme ISO 228 / Parallel gas in conformity with ISO 228.

Tubos de conexión / Connection Tubes

Racores varios para instalaciones neumáticas.
 Tubos metálicos en general.

Various types of fittings used on the pneumatic systems and metallic threaded tubes.

Temperaturas / Temperatures

Temperatura mínima / Minimum temperature: **-20 °C**
 Temperatura máxima / Maximum temperature: **+80 °C**

Fluidos compatibles / Fluids

Aire comprimido / Compressed air.

6060

VÁLVULA DE CORREDERA - SLIDE VALVE



Código Code	A	B	L	CH	Conf. Pack.
0606000001	1/8	25	48	14	10
0606000002	1/4	30	58	17	10
0606000003	3/8	35	70	22	5
0606000004	1/2	40	80	26	5

Válvulas unidireccionales o antiretorno / Unidirectional Valves or Non Return Valves

Este tipo de válvulas permiten el libre paso en un sólo sentido (indicado por la flecha en el cuerpo) y lo impide en el sentido contrario. Accionadas directamente por el aire, vienen normalmente utilizadas como dispositivos de seguridad, consintiendo en mantener en presión una parte del circuito, incluso cuando no existe presión en la alimentación.

This kind of valves allow the free passage in only one direction, the one showed with the arrow marked on the body. They do not allow the passage on the opposite way, i.e non return. They operate directly with the air that goes through, they are normally used as safety device, permitting to keep pressure in a part of the circuit, also when the feeding pressure has been taken off.

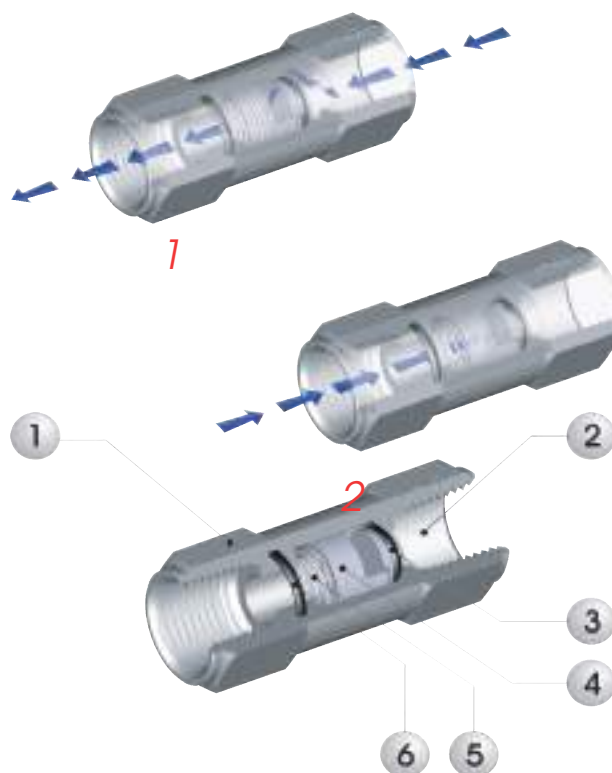

Materiales y Componentes / Component Parts and Materials

- 1 Cuerpo en latón niquelado
- 2 Parte posterior en latón niquelado
- 3 Junta tórica O-Ring en NBR 70
- 4 Obturador en latón niquelado
- 5 Muelle de mantenimiento en acero AISI 302
- 6 Junta tórica O-Ring en NBR 70

- 1 Nickel-plated Brass Body
- 2 Nickel-plated Brass Valve Back Part
- 3 NBR 70 O-RING Seals
- 4 Nickel-plated Brass Shutter
- 5 Steel AISI 302 Keep spring
- 6 NBR 70 O-RING Seals

Presiones / Pressures

Presión mínima / Minimum pressure: **2 bar (0.2 MPa)**
 Presión máxima / Maximum pressure: **8 bar (1 MPa)**
 Presión indicativa de apertura: **0.2 bar (0,02 MPa)**
Approximate opening pressure: 0.2 bar (0,02 MPa)

Temperaturas / Temperatures

Temperatura mínima / Minimum temperature: **-20 °C**
 Temperatura máxima / Maximum temperature: **+80 °C**

Roscas / Threads

Gas cilíndrica conforme ISO 228 / Parallel gas in conformity with ISO 228.

Tubos de conexión / Connection Tubes

Racores varios para instalaciones neumáticas.
 Tubos metálicos en general.

Various types of fittings used on the pneumatic systems and metallic threaded tubes.

Fluidos compatibles / Fluids

Aire comprimido / Compressed air.

ATENCIÓN!

EL ESCAPE A ATMOSFERA EXCLUYE EL USO DE LA VÁLVULA CON GASES TOXICOS, CORROSIVOS O INFLAMABLES.

ATTENTION!

THE FREE EXHAUST TO ATMOSPHERE DO NOT ALLOW TO USE THE VALVE WITH TOXICS, CORROSIVES AND INFLAMMABLES GAS.

6062

VÁLVULA UNIDIRECCIONAL HEMBRA-HEMBRA - FEMALE-FEMALE NON RETURN VALVE

**BAJO PEDIDO JUNTA EN FKM
IF REQUIRED FKM O-RING**

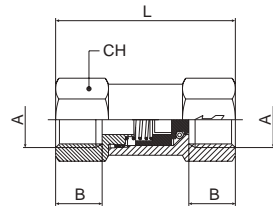

Código Code	A	B	L	CH	Conf. Pack.
060620001	M5	5.5	26.5	8	10
060620002	1/8	8.5	35.5	13	10
060620003	1/4	11	43	17	10
060620004	3/8	12	58	24	10
060620005	1/2	15	63	24	10

6063

VÁLVULA UNIDIRECCIONAL MACHO-HEMBRA - MALE-FEMALE NON-RETURN VALVE

**BAJO PEDIDO JUNTA EN FKM
IF REQUIRED FKM O-RING**

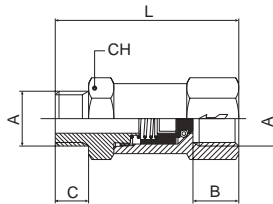

Código Code	A	B	C	L	CH	Conf. Pack.
060630001	M5	5.5	4	34.5	8	10
060630002	1/8	8.5	6	37.5	14	10
060630003	1/4	11	8	46.5	17	10
060630004	3/8	12	9	61	24	10
060630005	1/2	15	10	64	24	10

6064

VÁLVULA UNIDIRECCIONAL TUBO-TUBO - TUBE-TUBE PUSH-IN CONNECTIONS NON-RETURN VALVE

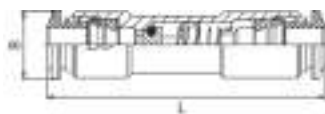

Código Code	Tubo Tube	L	B	Conf. Pack.
060640001	4	44.5	10	10
060640002	6	52	12.5	10
060640003	8	56	14	10

Características de caudal con escape de aire libre

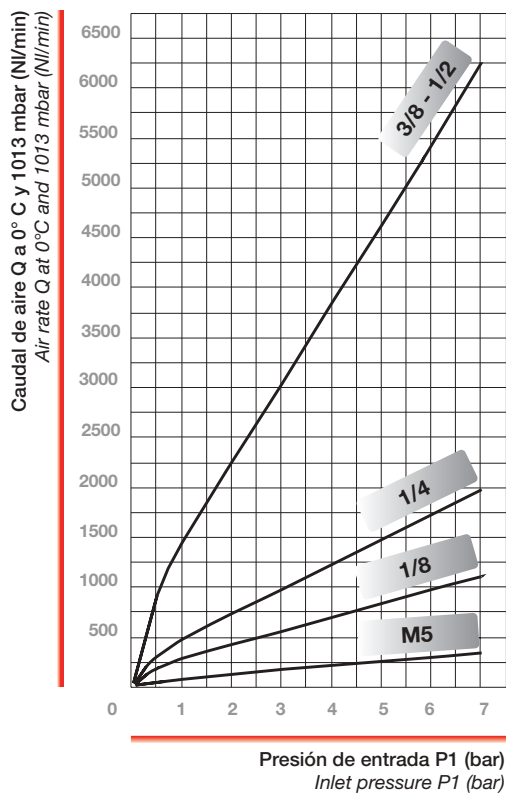

Características de caudal con pérdida de carga de 1 bar

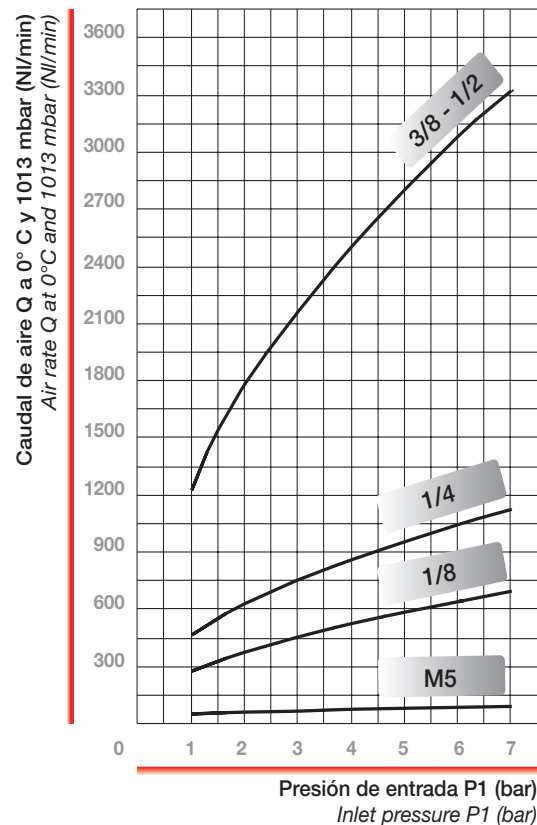

Válvulas de Bloqueo / Block Valve

Las válvulas de bloqueo Aignep son dispositivos a pilotaje neumático para el control del movimiento de un cilindro. Montadas directamente en la entrada y salida del cilindro permiten bloquear la carrera del cilindro en caso de caída de presión en el pilotaje.

Son utilizadas como sistemas de seguridad: en caso de paro de emergencia, rotura de un tubo o falta de aire bloquean los dispositivos en movimiento por el cilindro evitando daños de los mismos o riesgos de los operarios.

Es posible su utilización para parar un cilindro en cualquier posición intermedia si se precisa.

Versiónes: Disponibles en versión unidireccional y bidireccional.

Caudal: Las válvulas tienen un paso total, debido a que no existen reducciones de sección y el flujo no pasa por el muelle.

Compactas y versátiles: El tamaño es muy reducido y es posible orientar la conexión roscada y el pilotaje. **Rosca:** Es posible conectar un regulador de caudal a la válvula de bloqueo para controlar la velocidad del cilindro.

The AIGNEP's block valves are pneumatic driving devices used to control the movement of the cylinder. Assembled directly on the inlet and outlet ports of the cylinder allow to lock the piston stroke in case of pressure drop of the driving. They are used as safety devices in case of emergency stop, brake of a tube or air missing, they lock the apparatus moved by the cylinder avoiding damages to the devices or injury risks for the runners. It is also possible to use them to stop the piston into intermediate positions whenever the application requires such solutions.

Versions: They are available in uni-direction and bi-directional versions

Flow rate: These valves are full bore, there do not have reduction of section and the flow does not pass through the spring.

Compactness and Versatility: The overall dimensions are extremely reduced and it is possible to orient both the threaded connection as well as the hose connection for the driving.

Threaded connection: It is possible to connect the flow regulator at the inlet of the valve in order to adjust the speed of the cylinder.

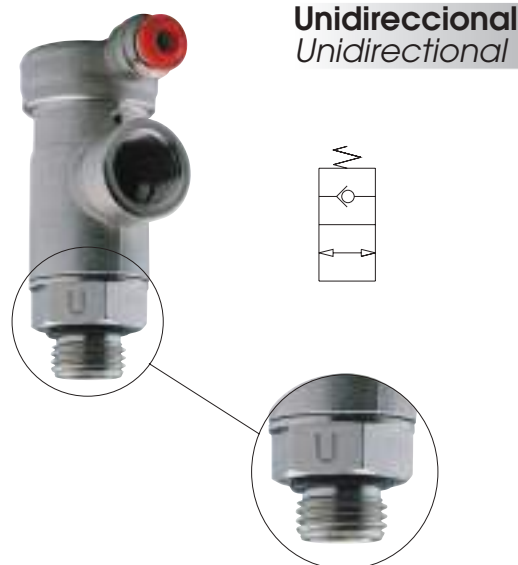

Código: 8880
Code: 8880



Código: 8890
Code: 8890

Características técnicas / Technical Characteristics

Medida / Size	1/8	1/4
Presión de ejercicio / Working pressure	Min. 0.3 – Max. 10 bar	
Temperatura de ejercicio / Working temperature	Min. -20°C Max. +80°C	
Caudal nominal (6 bar) / Flow rate (6 bar)	750 NI/min	1420 NI/min
Diámetro nominal / Orifice	Ø5.5	Ø8
Fluido / Fluids	Aire filtrado lubricado o no lubricado Filtered and lubricated compressed air as well as non lubricated air	

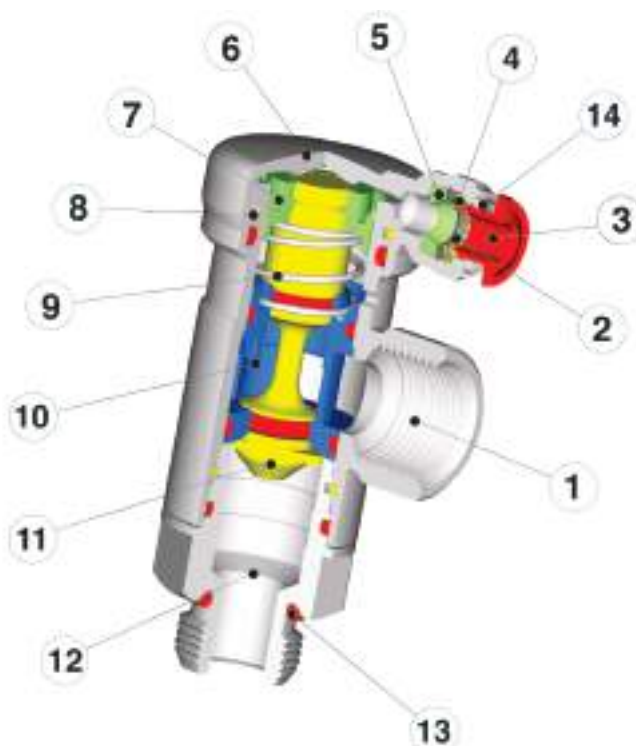

Materiales y Componentes / Component Parts and Materials

- | | |
|--|---|
| 1 Cuerpo en latón niquelado | 1 Nickel plated brass Body |
| 2 Anillo de seguridad en tecnopolímero | 2 Tecnopolymeric Safety ring |
| 3 Anillo extracción tubo en resina acetálica | 3 Acetalic Resin Collect |
| 4 Pinza de agarre en acero INOX AISI 304 | 4 Steel Clamping Washer |
| 5 Junta de labio en NBR | 5 NBR 70 Lip seal |
| 6 Cuerpo orientable en latón niquelado | 6 Nickel plated brass Orienting Cover Cap |
| 7 Junta de labio en poliuretano | 7 Polyuretane Lip seal |
| 8 Seeger en bronce | 8 Bronze Seeger |
| 9 Muelle en acero INOX AISI 302 | 9 Steel Spring |
| 10 Soporte obturador en latón | 10 Brass Shutter Support |
| 11 Obturador en latón | 11 Brass Shutter |
| 12 Base orientable en latón niquelado | 12 Nickel plated brass Orienting Base |
| 13 Junta en NBR 70 | 13 NBR 70 O-RING |
| 14 Cápsula en latón niquelado | 14 Nickel plated brass Capsule |

8880

VÁLVULA DE BLOQUEO UNIDIRECCIONAL - BLOCK VALVE UNIDIRECTIONAL COUPLING

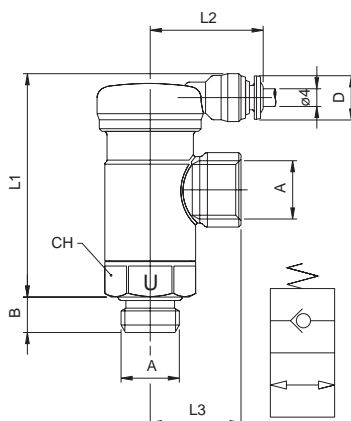

Código Code	A	B	L1	L2	L3	CH	D	Conf. Pack.
088800002	1/8	6	50	25	18.5	18	10	5
088800003	1/4	8	50.5	25	20.5	18	10	5



8890

VÁLVULA DE BLOQUEO BIDIRECCIONAL - BLOCK VALVE BIDIRECTIONAL COUPLING

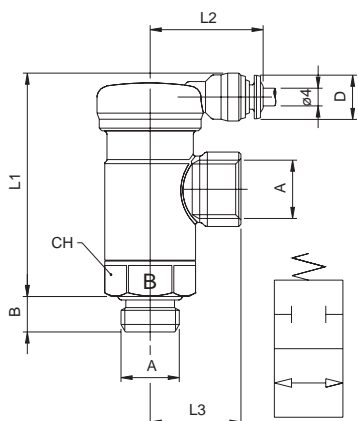

Código Code	A	B	L1	L2	L3	CH	D	Conf. Pack.
0889000002	1/8	6	50	25	18.5	18	10	5
0889000003	1/4	8	50.5	25	20.5	18	10	5



Válvula de Bloqueo Unidireccional 8880 / Unidirectional Block Valve 8880

Cilindro en Movimiento
Cylinder in action

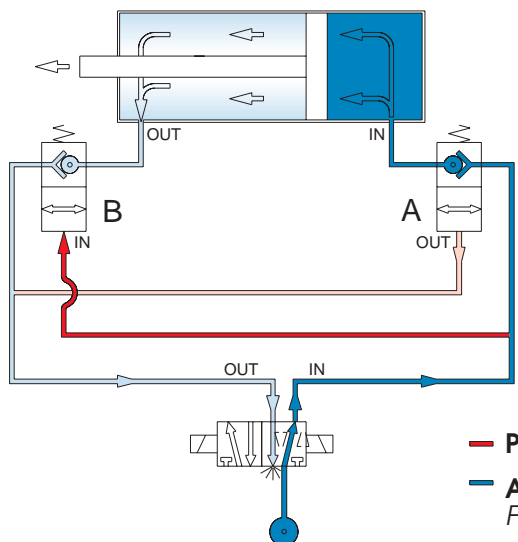

Circuito Neumático
Pneumatic Circuit

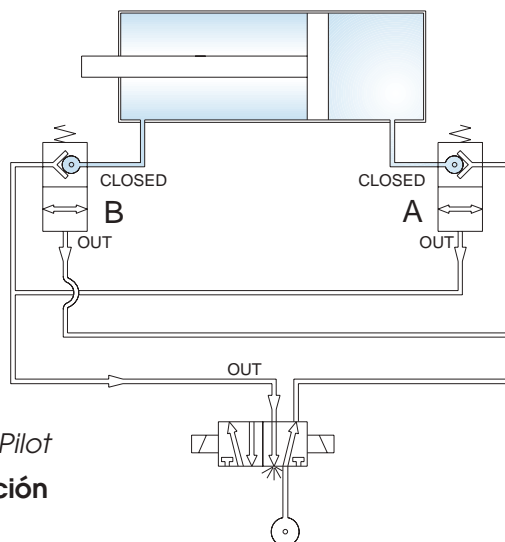

Cilindro Bloqueado
Stopped Cylinder

— Pilotaje - Pilot
— Alimentación Feeding

Alimentando la válvula de bloqueo A y el pilotaje B se consigue el movimiento del pistón en una dirección; alimentando la válvula de bloqueo B y el pilotaje A se consigue el movimiento en la dirección opuesta.

Cortando la alimentación a la totalidad del circuito (por ej. en caso de emergencia) las válvulas bloquean el cilindro en la posición en la que se encuentra, incluso en el caso en que el cilindro este sometido a alguna carga.

Feeding the block valve A and the pilot B you allow the movement of the piston in one direction; feeding the block valve B and the pilot A you allow the movement of the piston in the opposite direction.

Taking away the feeding within the circuit (for example in case of emergency) the block valves lock the cylinder into the position where it is at that moment, even if at the piston are attached some loads.

Instalación / Installation

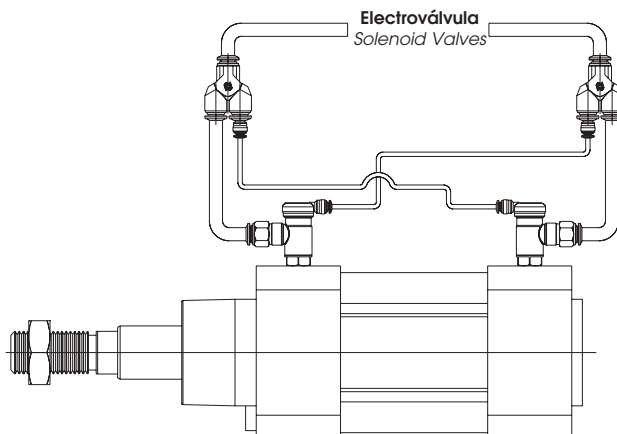

Válvula de Bloqueo Bidireccional 8890 / Bidirectional Block Valve 8890

Cilindro en Movimiento
Cylinder in action

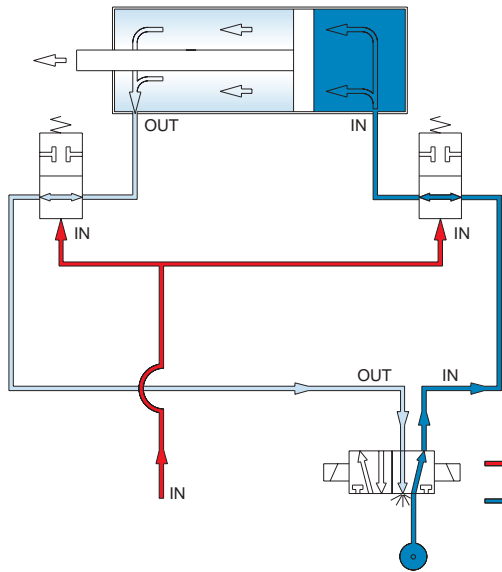

Circuito Neumático
Pneumatic Circuit

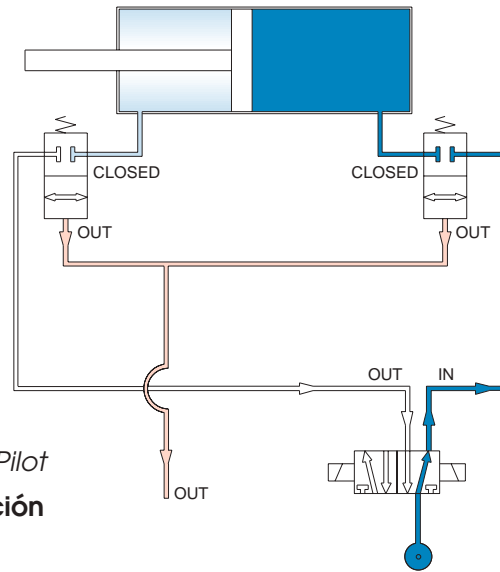

Cilindro Bloqueado
Stopped Cylinder

— **Pilotaje - Pilot**
— **Alimentación Feeding**

El circuito de pilotaje y el circuito de alimentación del cilindro son independientes. Alimentando el circuito de pilotaje las válvulas de bloqueo permiten el movimiento alternado del cilindro.

Cortando la alimentación del circuito de pilotaje las válvulas bloquean el cilindro en la posición en la que se encuentra, incluso en el caso en que el cilindro este sometido a alguna carga.

The driving circuit and the feeding circuit of the cylinder are independent. Feeding the driving circuit the block valves allow the alternate movement of the cylinder.

Taking away the feeding to the driving circuit the block valves lock the cylinder into the position where it is at that moment, even if at the piston are attached some loads.

Instalación / Installation

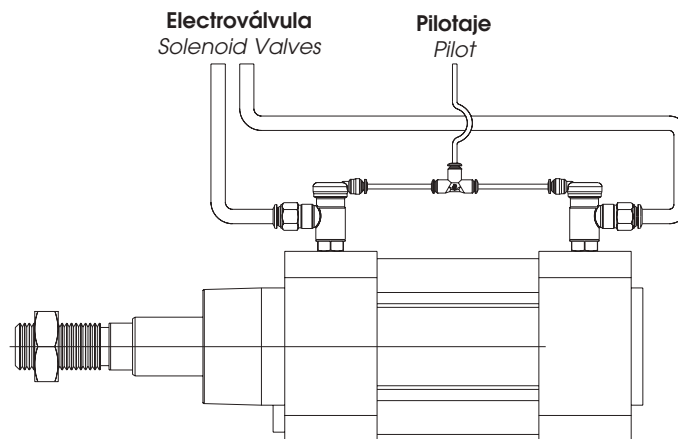

Presión de Pilotaje / Pilot Pressure

Presión mínima de pilotaje para accionar la válvula, en relación a la presión de entrada.

Pilot minimum pressure to feed the valve compared to the inlet pressure.

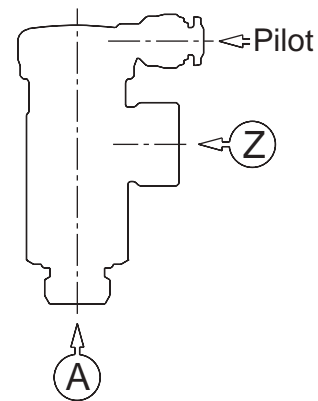

Unidireccional / Unidirectional 8880

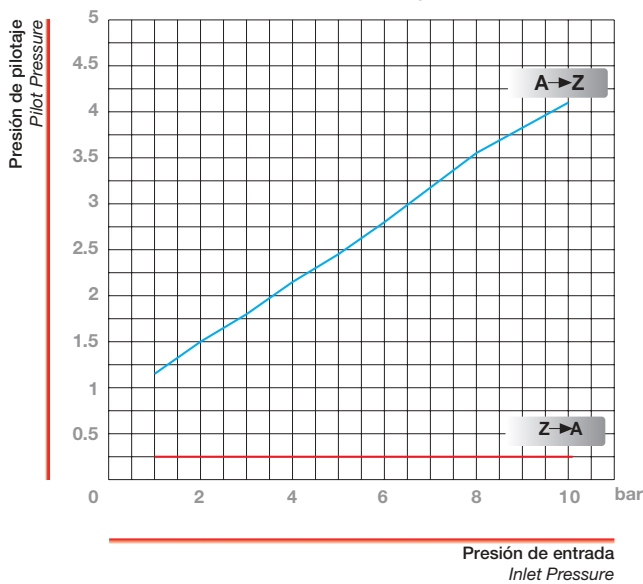

Bidireccional / Bidirectional 8890

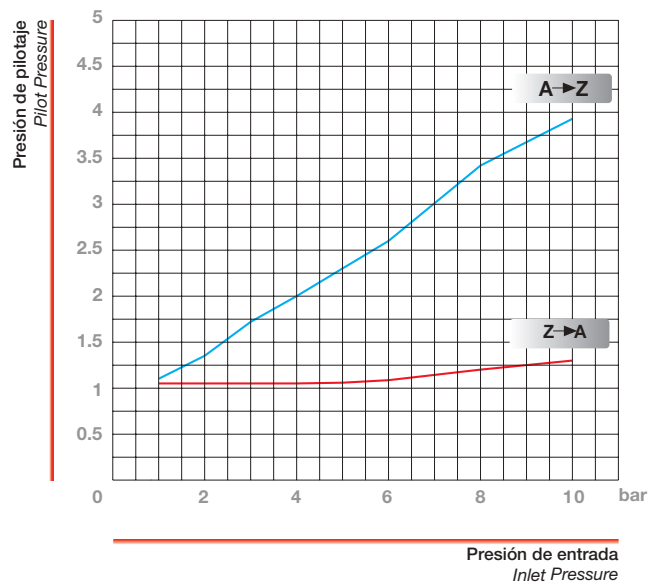

Curvas características de flujo / Characteristic curves of flow

Medida / Size 1/8

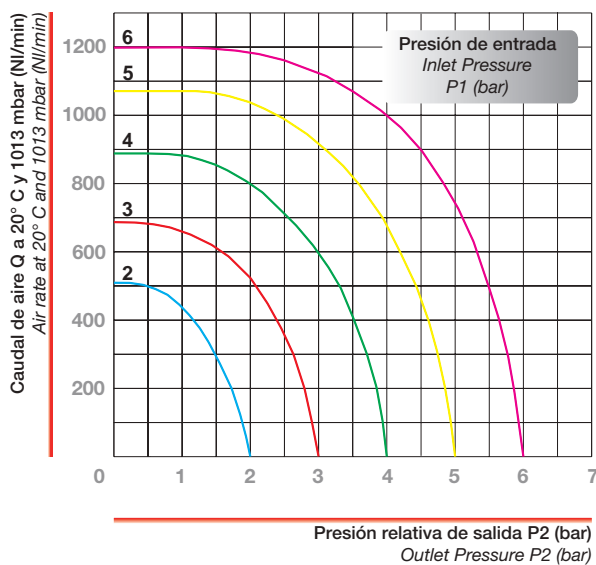

Medida / Size 1/4

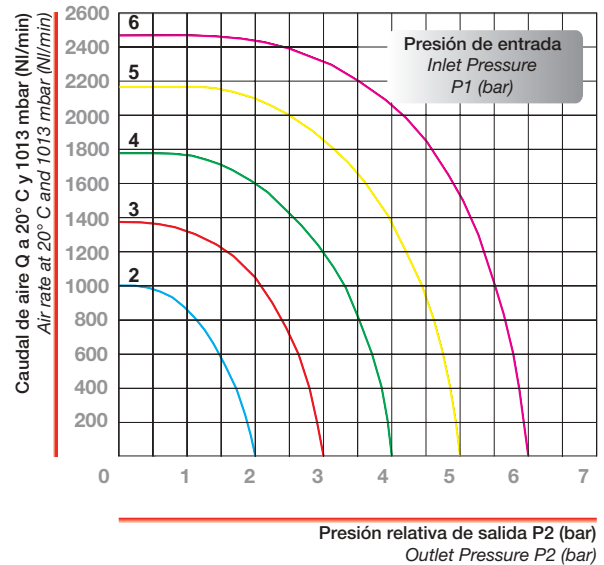



Serie Ghilux

Válvulas a esfera
Ball valves

Características técnicas / Technical Characteristics

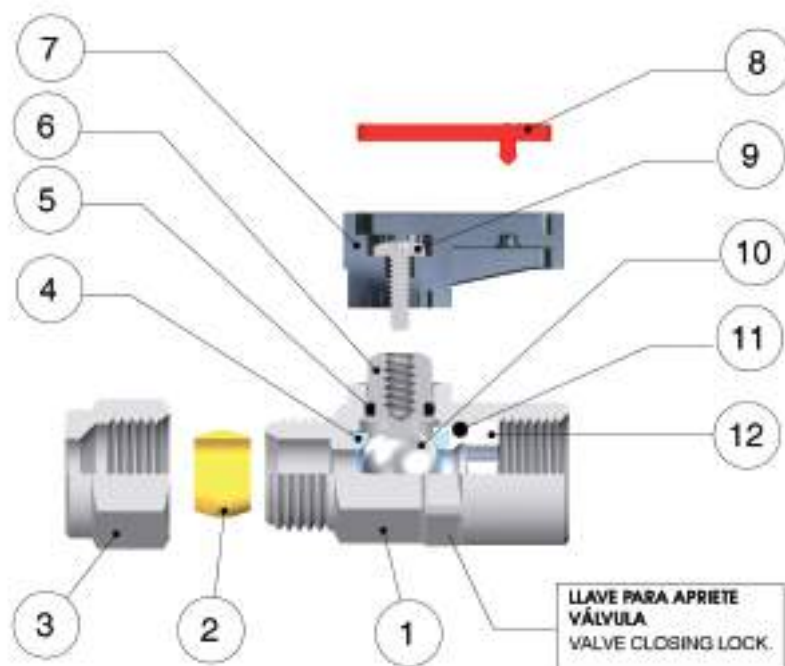

BS EN 331:1998

Tested by GL to
BS EN 331:1998

LLAVE PARA APRIETE
VÁLVULA
VALVE CLOSING LOCK.

Materiales y componentes / Specifications

- | | |
|---|---|
| 1 Cuerpo en latón cromado | 1 Chrome Nickel-plated Brass Body |
| 2 Bicono en latón (PTFE bajo demanda) | 2 Brass Olive (if Requested PTFE) |
| 3 Tuerca en latón cromado | 3 Chrome Nickel-plated Brass Nut |
| 4 Junta sede esfera en PTFE | 4 PTFE Seats |
| 5 Junta tórica O-RING en NBR 70 (FKM bajo demanda) | 5 NBR 70 Seal O-RING (FKM if required) |
| 6 Eje en latón cromado | 6 Chrome Nickel-plated Brass Spindle |
| 7 Maneta en PA66 con fibra de vidrio | 7 PA66 Glass reinforced Handle |
| 8 Plaqueta en PA6 | 8 PA6 Plate |
| 9 Tornillo en acero | 9 Steel Screw |
| 10 Esfera en latón cromado | 10 Chrome Nickel-plated Brass Ball |
| 11 Junta tórica O-RING en NBR 70 (FKM bajo demanda) | 11 NBR 70 Seal O-RING (FKM if required) |
| 12 Racor en latón | 12 Brass Fitting |

Presiones / Pressures

Presión mínima / Minimum Pressure: 0.99 bar (0.099MPa)
Presión máxima / Maximum pressure: 20 bar (2 MPa)

Temperaturas / Temperatures

Temperatura mínima / Minimum temperature: -20 °C
Temperatura máxima / Maximum temperature: +80 °C

Roscas / Threads

Gas cónica conforme ISO 7.1, BS 21, DIN 2999 / Tapered gas in conformity with ISO 7.1, BS 21, DIN 2999.
Gas cilíndrica conforme ISO 228 Clase A / Parallel gas in conformity with ISO 228 Class A.

Tubos de conexión / Connection Tubes

Tubos en cobre, tubos metálicos en general, racordaje vario.
Tubos en Nylon PA6, Rilsan PA11, etc... utilizando el correspondiente refuerzo art.10770

Tubes made in copper, metal in general and various fittings.
PA6, PA11 etc. with an inside support bush art 10770.

Fluidos compatibles / Fluids

Aire comprimido, agua, aceite.
1ª y 2ª familia de gases a media presión
3ª familia de gas a baja presión.

Compressed air, water, oils.
1st and 2nd family gases at medium pressure.
3rd family gases at low pressure.

DIAGRAMA PRESIÓN-TEMPERATURA
 PRESSURE-TEMPERATURE RATINGS DIAGRAM

- PTFE + NBR
- PTFE + FKM

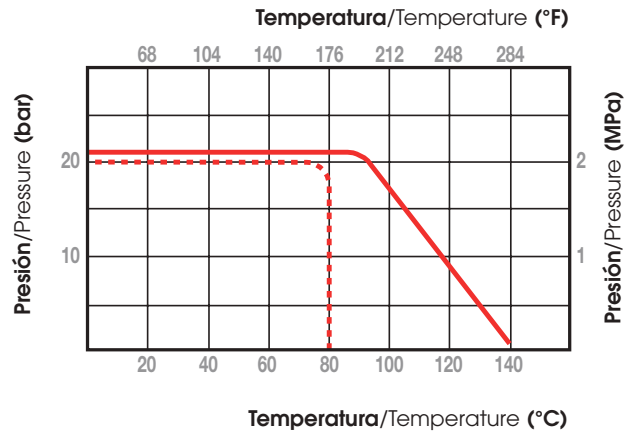

CURVA CARACTERÍSTICA DE FLUJO PARA AIRE RELATIVO A LAS VÁLVULAS A ESFERA GHILUX ART.6400 HEMBRA-HEMBRA
 CHARACTERISTIC CURVES OF FLOW FOR AIR PERTINENT TO THE BALL VALVES GHILUX ART. 6400 FEMALE-FEMALE

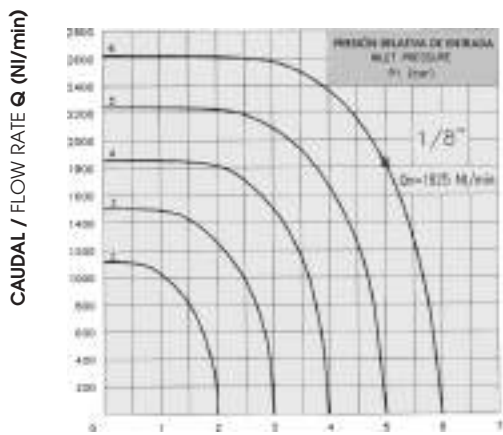

PRESIÓN RELATIVA SALIDA
 OUTLET PRESSURE P2 (bar)

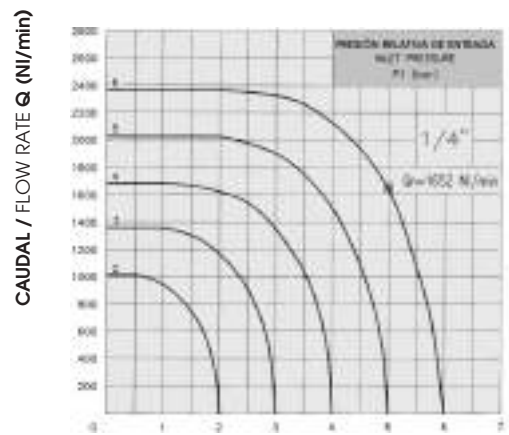

PRESIÓN RELATIVA SALIDA
 OUTLET PRESSURE P2 (bar)

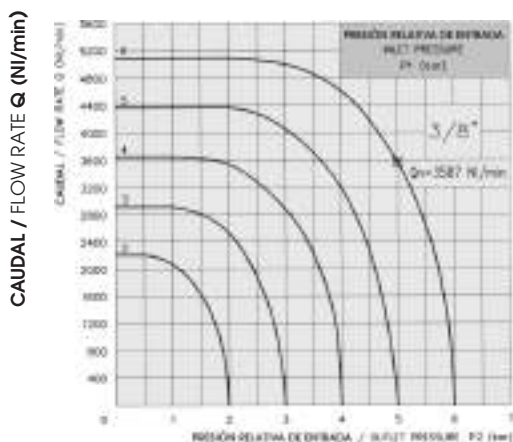

PRESIÓN RELATIVA SALIDA
 OUTLET PRESSURE P2 (bar)

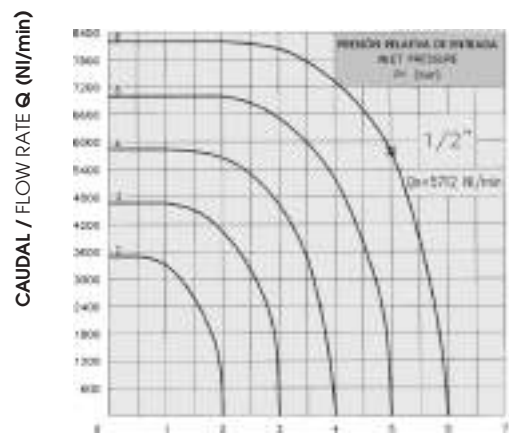

PRESIÓN RELATIVA SALIDA
 OUTLET PRESSURE P2 (bar)

CAUDAL / FLOW RATE Q (NI/min)

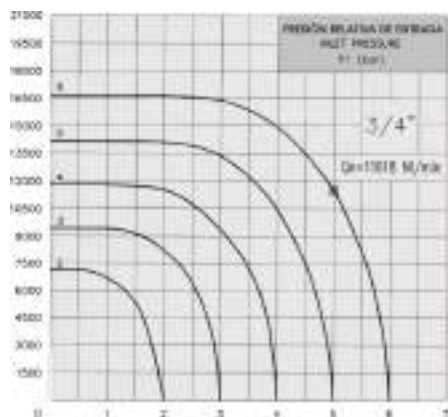

PRESIÓN RELATIVA SALIDA
OUTLET PRESSURE P2 (bar)

En los diagramas se observa el valor Qn relativo a una presión P1 = 6 bar y una presión P2 = 5 bar.

On the different diagrams is marked the value of flow rate Qn pertinent to a pressure P1 = 6 bar and to a pressure P2 = 5 bar.

CERTIFICADO DE PRUEBA N° 36794 REALIZADO POR EL "INSTITUTO GIORDANO" CON FECHA 13/06/1990.

TEST CERTIFICATE N° 36794 ISSUED BY THE "ISTITUTO GIORDANO" ON THE 13/06/1990.

DIAGRAMA DE LAS CARACTERÍSTICAS CAUDAL-PÉRDIDA DE CARGA RELATIVO A LAS VÁLVULAS A ESFERA ART.6400 HEMBRA-HEMBRA PARA AGUA
DIAGRAM OF THE FLOW RATE AND PRESSURE DROP CHARACTERISTICS PERTINENT TO THE BALL VALVES GHILUX ART. 6400 FEMALE-FEMALE FOR WATER

PÉRDIDA DE CARGA / PRESSURE DROP ΔP (daPa) 1 daPa = 1,019 mm H2O

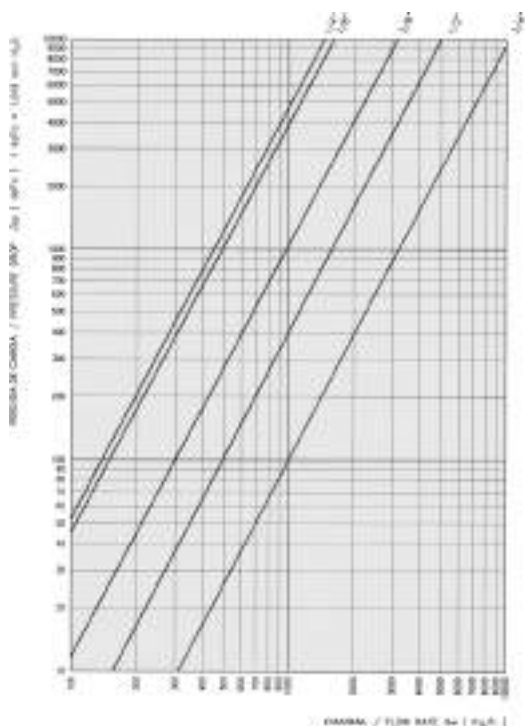

CAUDAL / FLOW RATE Qw (kg/h)

COEFICIENTES DE CAUDAL Kv
FLOW RATE FACTORS Kv

Representamos en la tabla los coeficientes de caudal Kv de las válvulas a esfera serie GHILUX, recordando que este coeficiente representa la cantidad de agua que pasa por la válvula por unidad de tiempo (Kg/h) a la temperatura de 15,5° C y que determina una caída de presión unitaria.

On the following table we specify the flow rate factor Kv of the ball valves GHILUX, we remind You that this factor represent the quantity of water that cross the valve in the unit time (Kg/h) at the temperature of 15.5° C and it determines a drop of unitary pressure.

Medida Size	Coefficiente de Caudal Hidráulico Factor of hydraulic flow rate Kv (Kg/h)
1/8"	1614
1/4"	1461
3/8"	3164
1/2"	5051
3/4"	10274

CERTIFICADO DE PRUEBA N. 36547 REALIZADO POR EL "INSTITUTO GIORDANO" CON FECHA 31/05/1990
TEST CERTIFICATE N. 36547 ISSUED BY THE "ISTITUTO GIORDANO" ON THE 31/05/199

COMO HACER UN PEDIDO

Los válvulas a esfera standard de la serie GHILUX son suministradas con:

- Tratamiento superficial CROMADO
- Bicono en LATÓN
- Maneta CORTA
- Plaqueta ROJA

Los artículos standard pueden ser pedidos, especificando solo ARTÍCULO, MEDIDA y CANTIDAD.

Cualquier variación a lo considerado standard debe ser especificado en el pedido mediante una descripción (ej. Maneta Larga, Plaqueta verde, etc...).

HOW TO ORDER

The ball valves GHILUX series are supplied with:

- Surface treatment of CHROME-NICKEL PLATED
- BRASS Olive
- SHORT Handle
- RED Plate

To order the standard items simply specify the ARTICLE CODE, SIZE and QUANTITY.

Every kind of changes must be specified on the order using a description (ex. LONG handle, GREEN plate, etc.).

6430

VÁLVULA TUBO - HEMBRA G ISO 228 (MANETA STANDARD - PLAQUETA ROJA)

TUBE - FEMALE G ISO 228 VALVE (STANDARD HANDLE - RED PLATE)



Código Code	D	B	DN	ES	M	L	G	H	Conf. Pack.
0643000001	6	1/8	5.5	14-15	7	41	19	21	25
0643000002	8	1/8	5.5	14-15	7	43	19	21	25
0643000003	8	1/4	5.5	14-15	8	43	19	21	25
0643000004	10	3/8	8	18-19	9	48	19	22	10
0643000005	12	3/8	8	18-19	9	49	19	22	10
0643000006	14	1/2	10	22-23	10	55.5	26	30.5	10
0643000007	15	1/2	10	22-23	10	55.5	26	30.5	10
0643000098	16	3/4	14	28-30	12	63.5	50	33	5
0643000099	18	3/4	14	28-30	12	63.5	50	33	5

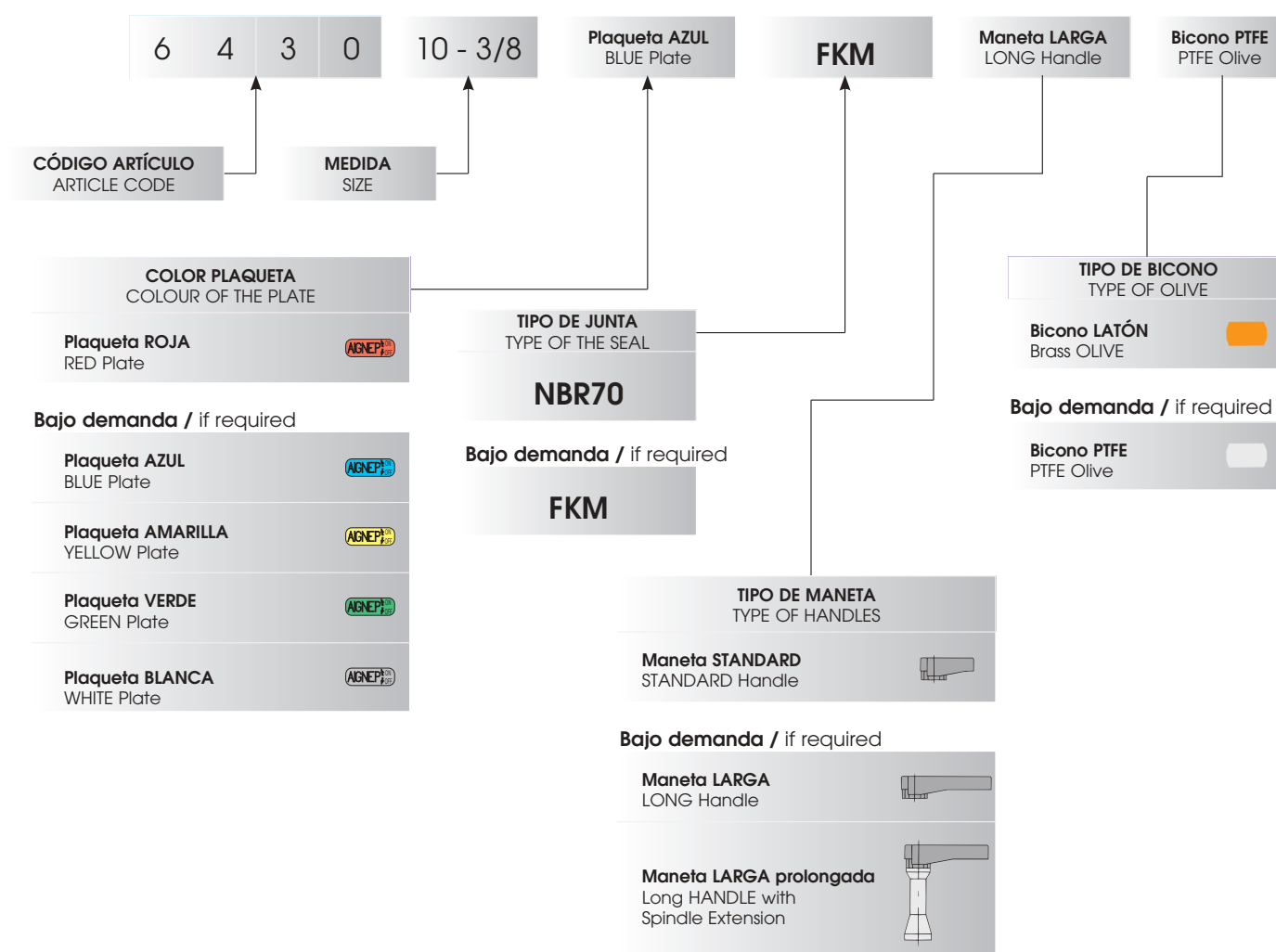

6300

HEMBRA RP ISO 7 - HEMBRA RP ISO 7 - FEMALE RP ISO 7 - FEMALE RP ISO 7



Código Code	A	B	DN	ES	F	M	L	G	H	Conf. Pack.
0630000001	1/8	1/8	5.5	14-15	7.4	7.4	36	19	21	25
0630000002	1/4	1/4	5.5	14-15	11	11	43	19	21	25
0630000003	3/8	3/8	8	18-19	11.4	11.4	47	19	22	10
0630000004	1/2	1/2	10	22-23	15	15	59	26	30.5	10
0630000005	3/4	3/4	14	28-30	16.3	16.3	67	50	33	5

6310

MACHO CÓNICO R ISO 7 - HEMBRA RP ISO 7 - TAPER MALE R ISO 7 - FEMALE RP ISO 7



Código Code	A	B	DN	ES	F	M	L	G	H	Conf. Pack.
0631000001	1/8	1/8	5.5	14-15	7.4	7.4	36	19	21	25
0631000002	1/4	1/8	5.5	14-15	11	7.4	40.5	19	21	25
0631000003	1/4	1/4	5.5	14-15	11	11	43	19	21	25
0631000004	3/8	3/8	8	18-19	11.4	11.4	46	19	22	10
0631000005	1/2	1/2	10	22-23	15	15	57	26	30.5	10
0631000006	3/4	3/4	14	28-30	16.3	16.3	63	50	33	5

6320

MACHO CILÍNDRICO GA ISO 228 - HEMBRA RP ISO 7 - PARALLEL MALE GA ISO 228 - FEMALE RP ISO 7



Código Code	A	B	DN	ES	D	F	M	L	G	H	Conf. Pack.
0632000001	1/8	1/8	5.5	14-15	6.2	7	7.4	34.5	19	21	25
0632000002	1/4	1/8	5.5	14-15	8.2	8	7.4	35.5	19	21	25
0632000003	1/4	1/4	5.5	14-15	8.2	8	11	38	19	21	25
0632000004	3/8	3/8	8	18-19	10.2	9	11.4	41.5	19	22	10
0632000005	1/2	1/2	10	22-23	15.2	10	15	50	26	30.5	10
0632000006	3/4	3/4	14	28-30	18.2	12	16.3	56.5	50	33	5

6330

MACHO CÓNICO R ISO 7 - MACHO CILÍNDRICO GA ISO 228 - TAPER MALE R ISO 7 - PARALLEL MALE GA ISO 228



Código Code	A	B	DN	ES	D	F	M	L	G	H	Conf. Pack.
0633000001	1/8	1/8	5.5	14-15	6.2	7.4	7	33.5	19	21	25
0633000002	1/8	1/4	5.5	14-15	8.2	7.4	8	33.5	19	21	25
0633000003	1/4	1/8	5.5	14-15	6.2	11	7	38	19	21	25
0633000004	1/4	1/4	5.5	14-15	8.2	11	8	38	19	21	25
0633000005	3/8	3/8	8	18-19	10.2	11.4	9	41.5	19	22	10
0633000006	1/2	1/2	10	22-23	15.2	15	10	49	26	30.5	10
0633000007	3/4	3/4	14	28-30	18.2	16.3	12	55.5	50	33	5

6340

TUBO - HEMBRA RP ISO 7 - TUBE - FEMALE R ISO 7



Código Code	D	B	DN	ES	M	L	G	H	Conf. Pack.
0634000001	6	1/8	5.5	14-15	7.4	41.5	19	21	25
0634000002	8	1/8	5.5	14-15	7.4	43	19	21	25
0634000003	8	1/4	5.5	14-15	11	46	19	21	25
0634000004	10	3/8	8	18-19	11.4	50.5	19	22	10
0634000005	12	3/8	8	18-19	11.4	51.5	19	22	10
0634000006	14	1/2	10	22-23	15	61.5	26	30.5	10
0634000007	15	1/2	10	22-23	15	61.5	26	30.5	10
0634000098	16	3/4	14	28-30	16.3	68	50	33	5
0634000099	18	3/4	14	28-30	16.3	68	50	33	5

6350

MACHO CÓNICO R ISO 7 - TUBO - TAPER MALE R ISO 7 - TUBE

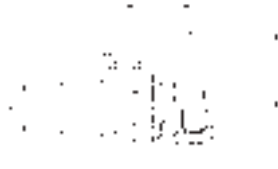

Código Code	A	D	DN	ES	F	L	G	H	Conf. Pack.
0635000001	1/8	6	5.5	14-15	7.4	40.5	19	21	25
0635000002	1/8	8	5.5	14-15	7.4	41.5	19	21	25
0635000003	1/4	6	5.5	14-15	11	46	19	21	25
0635000004	1/4	8	5.5	14-15	11	45	19	21	25
0635000005	3/8	10	8	18-19	11.4	50.5	19	22	10
0635000006	3/8	12	8	18-19	11.4	51.5	19	22	10
0635000007	1/2	14	10	22-23	15	59.5	26	30.5	10
0635000008	1/2	15	10	22-23	15	59.5	26	30.5	10
0635000109	3/4	16	14	28-30	16.3	67	50	33	5
0635000110	3/4	18	14	28-30	16.3	67	50	33	5

6400

HEMBRA G ISO 228 - HEMBRA G ISO 228 - FEMALE G ISO 228 - FEMALE G ISO 228



Código Code	A	B	DN	ES	F	M	L	G	H	Conf. Pack.
0640000001	1/8	1/8	5.5	14-15	7	7	35	19	21	25
0640000002	1/4	1/4	5.5	14-15	8	8	37	19	21	25
0640000003	3/8	3/8	8	18-19	9	9	42	19	22	10
0640000004	1/2	1/2	10	22-23	10	10	49	26	30.5	10
0640000055	3/4	3/4	14	28-30	12	12	58	50	33	5

6410

MACHO CILÍNDRICO GA ISO 228 - HEMBRA G ISO 228 - PARALLEL MALE GA ISO 228 - FEMALE G ISO 228



Código Code	A	B	DN	ES	F	M	L	G	H	Conf. Pack.
0641000001	1/8	1/8	5.5	14-15	7	7	34	19	21	25
0641000002	1/4	1/8	5.5	14-15	8	7	35	19	21	25
0641000003	1/4	1/4	5.5	14-15	8	8	35	19	21	25
0641000004	3/8	3/8	8	18-19	9	9	39	19	22	10
0641000005	1/2	1/2	10	22-23	10	10	45	26	30.5	10
0641000066	3/4	3/4	14	28-30	12	12	52	50	33	5

6420

MACHO CILÍNDRICO GA ISO 228 - MACHO CILÍNDRICO GA ISO 228 - PARALLEL MALE GA ISO 228 - PARALLEL MALE GA ISO 228



Código Code	A	B	DN	ES	F	M	L	G	H	Conf. Pack.
0642000001	1/8	1/8	5.5	14-15	7	7	32	19	21	25
0642000002	1/8	1/4	5.5	14-15	7	8	32	19	21	25
0642000003	1/4	1/4	5.5	14-15	8	8	33	19	21	25
0642000004	3/8	1/4	5.5	14-15	9	8	33	19	21	25
0642000005	3/8	3/8	8	18-19	9	9	37	19	22	10
0642000006	1/2	3/8	8	18-19	10	9	37	19	22	10
0642000007	1/2	1/2	10	22-23	10	10	42	26	30.5	10
0642000008	3/4	1/2	10	22-23	12	10	42	50	30.5	10
0642000009	3/4	3/4	14	28-30	12	12	49	50	33	5

6430

TUBO- HEMBRA G ISO 228 - TUBE - FEMALE G ISO 228



Código Code	D	B	DN	ES	M	L	G	H	Conf. Pack.
0643000001	6	1/8	5.5	14-15	7	41	19	21	25
0643000002	8	1/8	5.5	14-15	7	43	19	21	25
0643000003	8	1/4	5.5	14-15	8	43	19	21	25
0643000004	10	3/8	8	18-19	9	48	19	22	10
0643000005	12	3/8	8	18-19	9	49	19	22	10
0643000006	14	1/2	10	22-23	10	55.5	26	30.5	10
0643000007	15	1/2	10	22-23	10	55.5	26	30.5	10
0643000008	16	3/4	14	28-30	12	63.5	50	33	5
0643000009	18	3/4	14	28-30	12	63.5	50	33	5

6440

MACHO CILÍNDRICO GA ISO 228 - TUBO - PARALLEL MALE GA ISO 228 - TUBE



Código Code	A	D	DN	ES	F	L	G	H	Conf. Pack.
0644000001	1/8	6	5.5	14-15	7	39	19	21	25
0644000002	1/8	8	5.5	14-15	7	40	19	21	25
0644000003	1/4	6	5.5	14-15	8	40	19	21	25
0644000004	1/4	8	5.5	14-15	8	41	19	21	25
0644000005	1/4	10	5.5	14-15	8	44	19	21	25
0644000006	3/8	8	5.5	14-15	9	43	19	21	25
0644000007	3/8	10	8	18-19	9	46	19	22	10
0644000008	3/8	12	8	18-19	9	47	19	22	10
0644000009	3/8	14	8	18-19	9	50.5	19	22	10
0644000010	3/8	15	8	18-19	9	50.5	19	22	10
0644000011	1/2	10	8	18-19	10	49	19	22	10
0644000012	1/2	12	8	18-19	10	50	19	22	10
0644000013	1/2	14	10	22-23	10	52.5	26	30.5	10
0644000014	1/2	15	10	22-23	10	52.5	26	30.5	10
0644000015	3/4	14	10	22-23	12	56.5	26	30.5	10
0644000016	3/4	15	10	22-23	12	56.5	26	30.5	10
0644000017	3/4	16	14	28-30	12	60.5	50	33	5
0644000018	3/4	18	14	28-30	12	60.5	50	33	5

* En las medidas 1/4-8, 1/4-10, 3/8-14, 3/8-15 la tuerca, el bicono y la rosca A son opuestos a la figura

* In the sizes 1/4-8, 1/4-10, 3/8-14, 3/8-15 the nut, the double cone and the thread A are at the opposite side of the picture.

6450

TUBO - TUBO - TUBE - TUBE



Código Code	D1	D	DN	ES	L	G	H	Conf. Pack.
064500001	6	6	5.5	14-15	46	19	21	25
064500002	6	8	5.5	14-15	48	19	21	25
064500003	8	8	5.5	14-15	48	19	21	25
064500004	10	8	5.5	14-15	51	19	21	25
064500005	10	10	8	18-19	55	19	22	10
064500006	10	12	8	18-19	56	19	22	10
064500007	12	12	8	18-19	57	19	22	10
064500008	14	10	8	18-19	59.5	19	22	10
064500009	14	12	8	18-19	60.5	19	22	10
064500010	15	10	8	18-19	59.5	19	22	10
064500011	15	12	8	18-19	60.5	19	22	10
064500012	14	14	10	22-23	63	26	30.5	10
064500013	15	14	10	22-23	63	26	30.5	10
064500014	15	15	10	22-23	63	26	30.5	10
064500015	16	14	10	22-23	68	26	30.5	10
064500016	16	15	10	22-23	68	26	30.5	10
064500017	18	14	10	22-23	68	26	30.5	10
064500018	18	15	10	22-23	68	26	30.5	10
064500019	18	16	14	28-30	71	50	33	5
064500020	18	18	14	28-30	71	50	33	5

6460

TUERCA - MACHO CÓNICO R ISO 7 - MILLED NUT - TAPER MALE R ISO 7

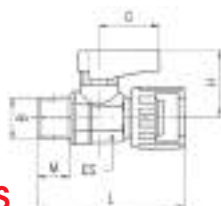
NO GAS

Código Code	B	DN	ES	M	L	G	H	Conf. Pack.
064600001	1/8	5.5	14-15	7.4	44	19	21	10
064600002	1/4	5.5	14-15	11	49.5	19	21	10
064600003	3/8	8	18-19	11.4	50	19	21	10

6470

TUERCA - HEMBRA G ISO 228 - MILLED NUT - FEMALE G ISO 228

NO GAS

Código Code	B	DN	ES	M	L	G	H	Conf. Pack.
064700001	1/8	5.5	14-15	7	46	19	21	10
064700002	1/4	5.5	14-15	8	46	19	21	10

6500

VÁLVULA CON PIE DE ANCLAJE TUBO - TUBO - FOOT MOUNTED BALL VALVE TUBE-TUBE

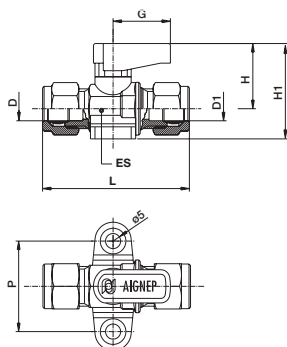

Código Code	D	D1	DN	ES	L	H	H1	G	P	Conf. Pack.
065000001	8	8	5.5	14-15	50	21	32	19	30	10

6540

VÁLVULA A L MACHO CILÍNDRICO GA ISO 228 - MACHO CÓNICO R ISO 7 - ELBOW VALVE PARALLEL MALE GA ISO 228-TAPER MALE R ISO 7



Código Code	A	B	DN	ES	ES1	L	H	H1	G	Conf. Pack.
0654000001	1/4	1/4	5.5	14-15	17	48	21	17	19	10

6560

VÁLVULA PARA TUBO AUTOMÁTICO - VALVE WITH PUSH-IN CONNECTIONS

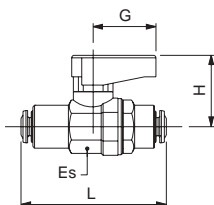

Código Code	Tubo Tube	Tubo Tube	DN	ES	L	G	H	Conf. Pack.
0656000001	4	4	3	14-15	44	19	21	10
0656000002	6	6	5	14-15	48	19	21	10
0656000003	8	8	5.5	14-15	48	19	21	10
0656000075	10	10	8	18-19	58.5	19	22	10
0656000076	12	12	10	22-23	66	26	30.5	10

NO GAS

6570

VÁLVULA A ESFERA MACHO - TUBO AUTOMÁTICO - BALL VALVE MALE - PUSH-FIT CONNECTIONS

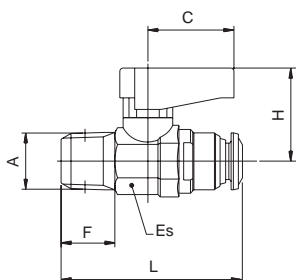

Código Code	A	Tubo Tube	F	Es	L	C	H	Conf. Pack.
0657000001	1/8	4	8.5	14-15	35	19	21	10
0657000002	1/8	6	8.5	14-15	40	19	21	10
0657000004	1/8	8	8.5	14-15	41.5	19	21	10
0657000003	1/4	6	12.5	14-15	38.5	19	21	10
0657000005	1/4	8	12.5	14-15	45.5	19	22	10

NO GAS

6600

VÁLVULA HEMBRA ISO 228 CON ESCAPE ATMÓSFERA - VALVE EXHAUST HOLE FEMALE ISO 228 - FEMALE ISO 228



Código Code	A	B	DN	ES	F	M	L	G	H	S	Conf. Pack.
0660000001	1/8	1/8	5.5	14-15	7	7	35	19	21	2.5	10
0660000002	1/4	1/4	5.5	14-15	8	8	37	19	21	2.5	10
0660000003	3/8	3/8	8	18-19	9	9	42	19	22	3	10

NO GAS

6700

VÁLVULA A 3 VÍAS HEMBRA G ISO 228 - FEMALE G ISO 228



NO GAS

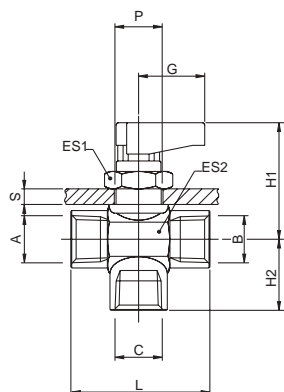

Código Code	A	B	C	DN	ES1	ES2	L	G	H1	H2	SMax	P	Conf. Pack.
0670000001	1/8-1/8-1/8	5	17	17	35	19	33.5	15.5	4.5	14.5	25		25
0670000002	1/4-1/4-1/4	5	17	17	37	19	33.5	17.5	4.5	14.5	25		25
0670000003	3/8-3/8-3/8	7	17	21	42	19	35	19.5	4.5	14.5	10		10

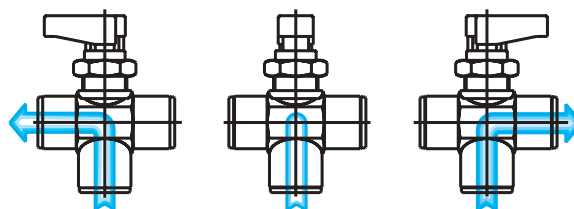

6710

VÁLVULA A 3 VÍAS HEMBRA G ISO 228 - FEMALE G ISO 228



NO GAS

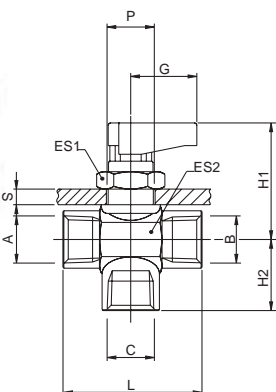

Código Code	A	B	C	DN	ES1	ES2	L	G	H1	H2	SMax	P	Conf. Pack.
0671000001	1/8-1/8-1/8	5	17	17	35	19	33.5	15.5	4.5	14.5	25		25
0671000002	1/4-1/4-1/4	5	17	17	37	19	33.5	17.5	4.5	14.5	25		25
0671000003	3/8-3/8-3/8	7	17	21	42	19	35	19.5	4.5	14.5	10		10

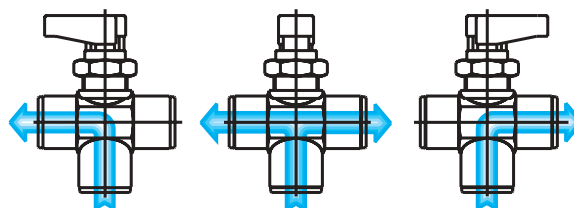

6720

VÁLVULA A L HEMBRA G ISO 228 - FEMALE G ISO 228



NO GAS

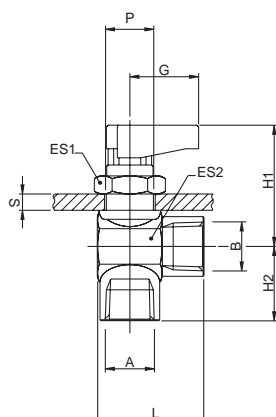

Código Code	A	B	DN	ES1	ES2	L	G	H1	H2	SMax	P	Conf. Pack.	
0672000001	1/8-1/8	5	17	17	28.5	19	33.5	15.5	4.5	14.5	25		25
0672000002	1/4-1/4	5	17	17	28.5	19	33.5	17.5	4.5	14.5	25		25
0672000003	3/8-3/8	7	17	21	31	19	35	19.5	4.5	14.5	10		10

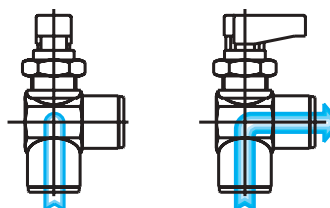

6900

MANETA STANDARD - STANDARD HANDLE

Código Code	Modelo Type	G	H	Conf. Pack.
06900A0300000	A	19	11	25
06900B0300000	B	26	15	25

A = Para válvulas de 1/8, 1/4, 3/8. B = Para válvulas de 1/2, 3/4.
A = For valves of 1/8, 1/4, 3/8. B = For valves of 1/2, 3/4.

6910

MANETA LARGA - LONG HANDLE

Código Code	Modelo Type	G	H	Conf. Pack.
06910A0300000	A	35	11	25
06910B0300000	B	50	15	25

A = Para válvulas de 1/8, 1/4, 3/8. B = Para válvulas de 1/2, 3/4.
A = For valves of 1/8, 1/4, 3/8. B = For valves of 1/2, 3/4.

Prolongación del eje de mando / Spindle Extension

Todos los modelos de válvulas a esfera de esta serie se pueden fabricar con el eje de maniobra prolongado (ver figura). Para confeccionar el pedido ver instrucciones en la página "COMO HACER UN PEDIDO" en el inicio de la serie.

All the valves "GHILUX" can be supplied with a spindle extension (see the picture). To order use the same instructions mentioned in the previous page "HOW TO ORDER".



6915

PROLONGACIÓN EJE DE MANDO (CON MANETA LARGA, TORNILLO Y PLAQUETA)
SPINDLE EXTENSION (WITH LONG HANDLE, SCREW, PLATE)

Código Code	Modelo Type	Medida válvula Valve size	L	Conf. Pack.
0691500001	A	1/8	58	10
		1/4	58	
		3/8	59	
0691500002	B	1/2	68	10
		3/4	70	

6920

PLAQUETA COLOREADA
COLOURED PLATE

Código Code	Modelo Type	Colores Colors	Conf. Pack.
06920A03000RO	A	ROJO / RED	100
06920B03000RO	B	ROJO / RED	100
06920A03000GI	A	*AMARILLO / YELLOW	100
06920B03000GI	B	*AMARILLO / YELLOW	100
06920A03000BL	A	AZUL / BLUE	100
06920B03000BL	B	AZUL / BLUE	100
06920A03000VE	A	VERDE / GREEN	100
06920B03000VE	B	VERDE / GREEN	100
06920A03000BN	A	BLANCO / WHITE	100
06920B03000BN	B	BLANCO / WHITE	100

*Plaqueta AMARILLA con marcaje EN 331 Para la utilización con Gas
 *YELLOW Plate with marking EN 331 For use with gas



A = Para válvulas de 1/8, 1/4, 3/8. B = Para válvulas de 1/2, 3/4.
A = For valves of 1/8, 1/4, 3/8. B = For valves of 1/2, 3/4.

6680

TUERCA - NUT

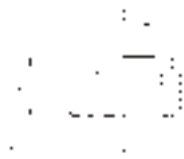

Código Code	D	A	H	CH	Conf. Pack.
066800001BSCT	6	1/8	11	12	100
066800001BJCT	8	1/4	12	15	100
066800001CGCT	10	3/8	13	19	100
066800001CLCT	12	3/8	14	19	100
066800001DBCT	14	1/2	15	24	100
066800001CPCT	15	1/2	15	24	100
066800001CSCT	16	3/4	17	30	100
066800001CXCT	18	3/4	17	30	100

10740

BICONO LATÓN - BRASS OLIVE



Código Code	D	H	Conf. Pack.
107400002X400	6	6.5	50
107400002X700	8	6.5	50
107400002X900	10	7.5	50
107400002Y100	12	8	50
107400002Y400	15	9	25
107400002Y700	18	10	25

10741

BICONO LATÓN - BRASS OLIVE

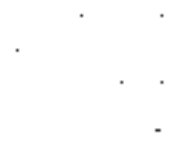

Código Code	D	H	Conf. Pack.
107410001Y300	14	12	50
107410001Y500	16	13.5	50

10760

BICONO PTFE - PTFE OLIVE



Código Code	D	H	Conf. Pack.
107600028X400	6	6.5	50
107600028X700	8	6.5	50
107600028X900	10	7.5	50
107600028Y100	12	8	50
107600028Y400	15	9	50
107600028Y700	18	10	50

10761

BICONO PTFE - PTFE OLIVE



Código Code	D	H	Conf. Pack.
107610028Y300	14	12	50
107610028Y500	16	13.5	50

Mini Válvulas a Esfera / Mini Ball Valves

Las mini válvulas a esfera Art. 6065 y Art. 6066 son válvulas de paso ON-OFF. La apertura y el cierre de la válvula se realiza manualmente accionando la maneta de mando de la esfera o mediante una llave.

The mini ball valves Art. 6065 and Art. 6066 are shutoff valves type ON-OFF. The opening and closing functions are made by hand, acting on the control spindle of the ball with the handle, or operated with a spanner.

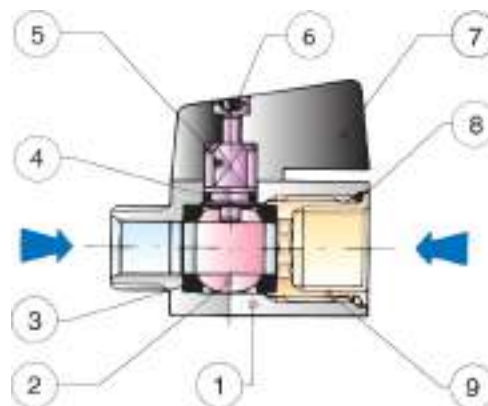

Materiales y componentes / Specifications

- 1 Cuerpo en latón niquelado
- 2 Esfera en latón niquelado
- 3 Junta sede esfera en PTFE
- 4 Junta tórica O-RING en NBR 70
- 5 Eje en latón niquelado
- 6 Tornillo en acero
- 7 Maneta en PA66 con fibra de vidrio
- 8 Junta tórica O-RING en NBR 70
- 9 Racor en latón niquelado

- 1 Nickel-plated Brass Body
- 2 Nickel-plated Brass Ball
- 3 PTFE Seats
- 4 NBR 70 Seal O-RING
- 5 Nickel-plated Brass Spindle
- 6 Steel Screw
- 7 PA66 Glass reinforced Handle
- 8 NBR 70 Seal O-RING
- 9 Nickel-plated Brass Fitting

Presiones / Pressures

Presión mínima / Minimum Pressure: 0.99 bar (0.099MPa)
 Presión máxima / Maximum pressure: 10 bar (1 MPa)

Temperaturas / Temperatures

Temperatura mínima / Minimum temperature: -25 °C
 Temperatura máxima / Maximum temperature: +90 °C

Roscas / Threads

Gas cilíndrica conforme ISO 228 Clase A / Parallel gas in conformity with ISO 228 Class A.

Tubos de conexión / Connection Tubes

Tubos metálicos en general, racordaje vario.
 Tubes made in metal in general and various fittings.

Fluidos compatibles / Fluids

Aire comprimido, agua, varios tipos de gas, aceite, etc.
 Compressed air, water, various types of oils, etc.

6065

VÁLVULA A ESFERA MINI HEMBRA - HEMBRA - MINI BALL VALVE FEMALE-FEMALE



NO GAS

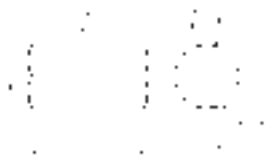

Código Code	A	DN	B	C	CH	Conf. Pack.
0606500001	1/8	6	39	38	21	10
0606500002	1/4	8	40	38	21	10
0606500003	3/8	8	42	38	21	10
0606500004	1/2	10	48	42	25	10
0606500005	3/4	12	54	47	30	10

6066

VÁLVULA A ESFERA MINI MACHO - HEMBRA - MINI BALL VALVE MALE-FEMALE



NO GAS

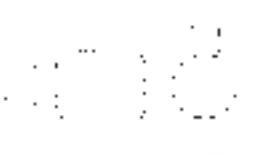

Código Code	A	DN	B	C	CH	Conf. Pack.
0606600001	1/8	6	39	38	21	10
0606600002	1/4	8	39	38	21	10
0606600003	3/8	8	40	38	21	10
0606600004	1/2	10	46	42	25	10
0606600005	3/4	12	51	47	30	10

Válvulas a Esfera / Ball Valves

Las válvulas a esfera de paso total son válvulas de paso del tipo ON-OFF, adaptadas a grandes caudales. La apertura y el cierre de la válvula se realiza manualmente accionando la maneta de mando de la esfera o mediante una llave.

The ball valves full port are shutoff valves type ON-OFF, suitable for high flow rate. The opening and closing functions are made by hand, acting on the control spindle of the ball with the handle, or operated with a spanner.

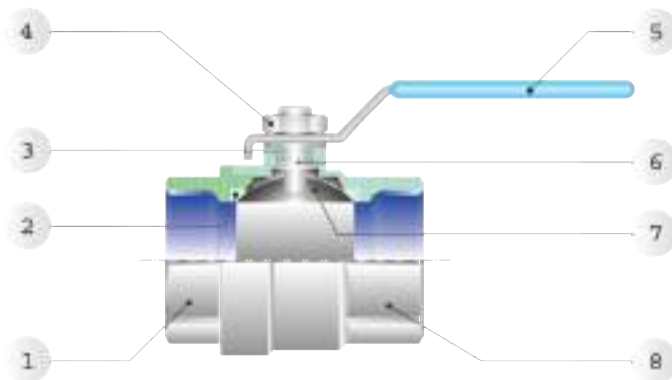

Materiales y componentes / Specifications

- | | |
|--|-----------------------------------|
| 1 Racor en latón niquelado | 1 Nickel-plated Brass Fitting |
| 2 Junta sede esfera PTFE | 2 PTFE Seats |
| 3 Junta eje en FKM o NBR | 3 NBR Stem Seal |
| 4 Junta para leva en Acero | 4 Steel Nut for lever |
| 5 Leva de maniobra en acero plastificado | 5 Steel plastified Lever handle |
| 6 Eje de maniobra en latón niquelado | 6 Nickel-plated Brass Stem |
| 7 Esfera en latón cromado | 7 Chrome Nickel-plated Brass Ball |
| 8 Cuerpo en latón cromado | 8 Nickel-plated Brass Body |

Roscas / Threads

Gas Cilíndrica conforme ISO 228 clase A.
Parallel gas in conformity with ISO 228 class A.

Tubos de conexión / Connection Tubes

Tubos metálicos en general, racordaje vario.
Tubes made in metal in general and various fittings.

**DIAGRAMA PRESIÓN-TEMPERATURA PRESSURE-TEMPERATURE RATINGS DIAGRAM

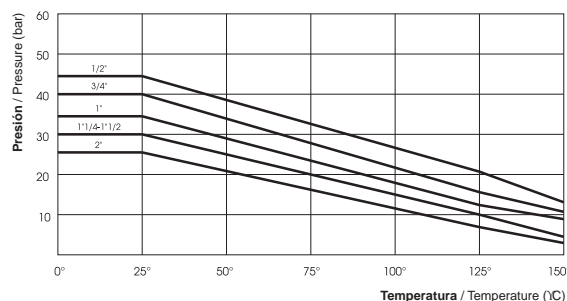

6067

VÁLVULA A ESFERA HEMBRA - HEMBRA - BALL VALVE, FEMALE - FEMALE

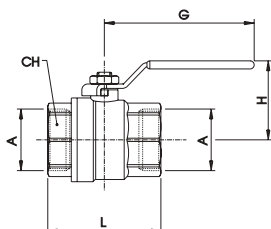

Código Code	A	DN	CH	L	G	H	Conf. Pack.
0606700001	1/2	15	25	46	75	47.5	10
0606700002	3/4	20	31	56.5	75	51	10
0606700003	1"	25	38	65.5	110	63	5
0606700004	1 1/4	32	48	77	110	68.5	2
0606700005	1 1/2	40	54	88.5	140	84.5	1
0606700006	2"	50	67	101.5	140	92.5	1

ART.6067:

Fluidos: Aire comprimido, agua, aceite.

Hasta el DN20: Ver los valores representados en el diagrama**

Del DN25 al DN50, Presión Máx: 18 bar

Fluid: Compressed air, water, oil.

DN 15 and 20: Use Diagram condition **

From DN25 to DN50, Max Pressure: 18 bar

6068

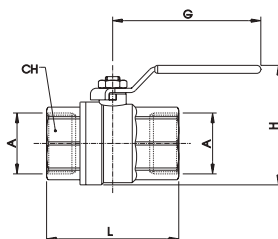
VÁLVULA A ESFERA PARA GAS HEMBRA - HEMBRA - GAS BALL VALVE, FEMALE - FEMALE

Código Code	A	DN	CH	L	G	H	Conf. Pack.
0606800001	1/2	15	26	59	88	58	10
0606800002	3/4	20	32	67.3	88	65	10
0606800003	1"	25	40	77.5	90	74	5
0606800004	1"1/4	32	49	92	90	85	2
0606800005	1"1/2	40	55	101.5	134	100	1
0606800006	2"	50	68	122.5	134	116.5	1

ART.6068:
Del DN15 al DN50: Fluidos: 1º y 2º Familia de gases a media presión y 3º familia de gas a baja presión. HOMOLOGADO EN 331 hasta presión Máx: 5 bar
From DN 15 to 50: Fluids: 1st and 2nd gas family to medium pressure and 3th gas family to low pressure OMOLOGATED EN331 to Max pressure: 5bar

6069

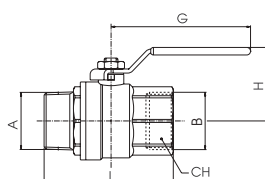
VÁLVULA A ESFERA MACHO - HEMBRA - BALL VALVE MALE - FEMALE

Código Code	A	B	DN	CH	L	G	H	Conf. Pack.
0606900001	1/2	1/2	15	25	56	75	47.5	10
0606900002	3/4	3/4	20	31	63.5	75	51	10
0606900003	1"	1"	25	38	74	110	63	5
0606900004	1"1/4	1"1/4	32	48	85	110	68.5	2
0606900005	1"1/2	1"1/2	40	54	100	140	84.5	1
0606900006	2"	2"	50	67	121.5	140	92.5	1

ART.6069:

Fluidos: Aire comprimido, agua, aceite.

Hasta el DN20: Ver los valores representados en el diagrama Pag. 10.15 - Del DN25 al DN50, Presión Máx: 18 bar**

Fluid: Compressed air, water, oil.

DN 15 and 20: Use Diagram condition Pag. 10.15** - From DN25 to DN50, Max Pressure: 18 bar

Filtro a "Y" / "Y" Filter

Materiales y componentes / Specifications

Cuerpo en latón de 1/4 a 2"

Brass body from 1/4 to 2"

Tapón en latón

Brass Cap

Filtro en acero AISI 304

Steel AISI 304 Strainer

Junta cuerpo en NBR

NBR Body Seal

Presiones / Pressures

Presiones a temperaturas de referencia

Pressures to reference temperature:

18 BAR 80°C

16 BAR 100°C

10 BAR 120°C

Grado de filtración / Filtration degree

De 1/4 a 2" 500 µm; 2"1/2, 3" y 4" 800 µm.

From 1/4 to 2" 500 µm; 2"1/2, 3" e 4" 800 µm.

Fluidos compatibles / Fluids

Agua, Aceite.

Water, Oil.

Temperatura de ejercicio

Working temperature

De -20°C a +110°C con ausencia de vapor.

From -20°C to +110°C without steam.

6035

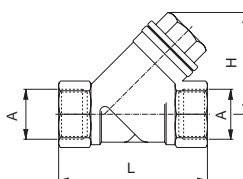
FILTRO "Y" PN 20 - "Y" FILTER PN 20

Código Code	A	DN	L	H	Conf. Pack.
0603500001	1/4	8	55	40	10
0603500002	3/8	10	55	40	10
0603500003	1/2	15	58	40	10
0603500004	3/4	20	70	50	10
0603500005	1"	25	87	56	5
0603500006	1"1/4	32	96	64	2
0603500007	1"1/2	40	106	73	2
0603500008	2"	50	126	89	1
0603500009	2"1/2"	65	150	107	1
0603500010	3"	80	170	120	1
0603500011	4"	100	219	161	1

Válvula de Retención / No return Valve

Características técnicas / Technical Characteristics

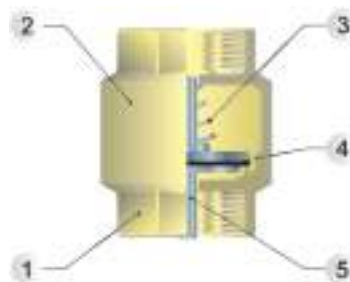

Materiales y componentes / Specifications

- | | |
|----------------------------------|--------------------------|
| 1 Cuerpo en latón | 1 Brass Body |
| 2 Cuerpo en latón | 2 Brass Cover Cap |
| 3 Muelle en Acero Inox. | 3 Stainless steel Spring |
| 4 Junta en NBR 65 SH/PS | 4 NBR 65 SH/PS Seal |
| 5 Obturador en material plástico | 5 Plastic Shutter |

Presiones / Pressures

Presión mínima / Minimum Pressure: 0.99 bar (0.099MPa)
 Presión máxima / Maximum pressure: 15 bar (1.5 MPa)

Temperaturas / Temperatures

Temperatura mínima / Minimum temperature: -20 °C
 Temperatura máxima / Maximum temperature: +110 °C

Fluidos compatibles / Fluids

Agua, Aire comprimido, Aceite.
 Water, Compressed Air, Oil.

6036

VÁLVULA DE RETENCIÓN - NON RETURN VALVE

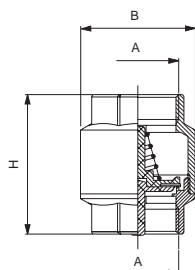

Código Code	A	H	B	Conf. Pack.
060360001	1/2	49	34.5	10
060360002	3/4	53.5	42.5	5
060360003	1"	58.5	47.5	5
060360004	1"1/4	66.5	60	2
060360005	1"1/2	72	69	2
060360006	2"	77	85	1

6037

VÁLVULA DE FONDO - FINAL VALVE

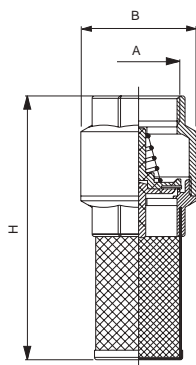

Código Code	A	H	B	Conf. Pack.
060370001	1/2	91	34.5	10
060370002	3/4	100.5	42.5	5
060370003	1"	105	47.5	5
060370004	1"1/4	125	60	4
060370005	1"1/2	140	69	2
060370006	2"	160	85	1

6038

FILTRO PARA VÁLVULA DE FONDO - STRETCHED NET-FILTER

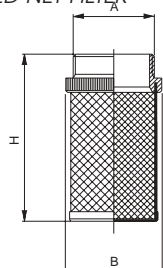

Código Code	A	B	H	Conf. Pack.
060380002	1/2	26	50	10
060380003	3/4	32	57	5
060380004	1"	41	56.5	5
060380005	1"1/4	49	68	5
060380006	1"1/2	55	79	5
060380007	2"	68	95	1



A
1800
15000

Serie **Accessories**

RACORDAJE STANDARD
FIXTURES AND FITTINGS

Características técnicas / Technical Characteristics



Presiones y Temperaturas / Pressures and Temperatures

Dada la variedad de productos que componen esta gama, no es posible definir valores de temperatura y presión válidos para todos los artículos. Seguidamente representamos las presiones máximas aconsejadas para los artículos del 2000 al 6080.

Due to the vastness of this range, it is not possible to define the exact values of temperature and pressure valid for all the items. Hereunder, we specify the values of the maximum pressure advised, from the art. 2000 to the 6080.

MEDIDA SIZE	PRESIÓN MÁXIMA RECOMENDADA MAXIMUM PRESSURE ADVISED	TEMPERATURA MÁXIMA MAXIMUM TEMPERATURE
1/8	150 bar	300° C
1/4	100 bar	300° C
3/8	75 bar	300° C
1/2	50 bar	300° C
3/4	85 bar	300° C
1"	80 bar	300° C

Los valores de presión de la tabla se han obtenido adoptando un coeficiente de seguridad 4. Para aplicaciones particulares rogamos consultar.

It must be taken into account that the pressure values indicated are calculated considering a Safety Factor of 4. We advised you to contact us if You use them in particular working conditions.

Materiales y componentes / Specifications

La mayor parte de los artículos de esta serie está compuesta de un solo material latón (OT UNI EN 12164/5 CW 614/7N) sometido a un tratamiento galvánico de niquelatura.

Artículos producidos en materiales diversos, vendrán especificados al interior del catálogo.

The main part of these fittings is made in brass (OT UNI EN 12164/5 CW 614/7N) and undergo to a nickel-plating process.

Different materials will be specified in the catalogue.

Roscas / Threads

Gas cónica conforme ISO 7.1, BS 21, DIN 2999 / Tapered gas in conformity with ISO 7.1, BS 21, DIN 2999.

Gas cilíndrica conforme ISO 228 Clase A / Parallel gas in conformity with ISO 228 Class A.

Métrica conforme ISO R/262 / Metric in conformity with ISO R/262.

Tubos de conexión / Connection Tubes

Tubo y racordaje en general.

Tubes and fittings in general.

Fluidos compatibles / Fluids

Agua, aceite, aire comprimido, fluidos en general para los campos hidráulicos, neumáticos y oleodinámicos, etc.

Water, oils, compressed air, fluids in general for the hydraulic, pneumatic and oildynamic plants etc.

2000

MACHÓN CÓNICO - NIPPLE (TAPER)



Código Code	A	B	L	CH	Conf. Pack.
0200000102NB	1/8	7.5	19.5	12	50
0200000103NB	1/4	11	27	14	50
0200000104NB	3/8	11.5	28	17	25
0200000105NB	1/2	14	33.5	22	25
0200000107NB	3/4	16.5	40	27	25
0200000109NT	1"	19	46.5	34	10

2010

MACHÓN CILÍNDRICO - NIPPLE (PARALLEL)

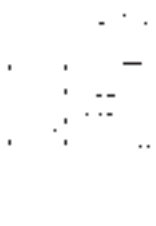

Código Code	A	B	L	CH	Conf. Pack.
020100001B5NB	M5	4	11.5	8	50
02010000102NB	1/8	6	16.5	14	50
02010000103NB	1/4	8	21	17	50
02010000104NB	3/8	9	23	19	25
02010000105NB	1/2	10	25.5	24	25

2020

MACHÓN CÓNICO DE REDUCCIÓN - REDUCING NIPPLE (TAPER)

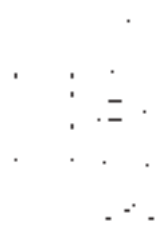

Código Code	A	A1	B	C	L	CH	Conf. Pack.
020200001ATNB	1/8	1/4	7.5	11	23.5	14	50
0202000013WNB	1/8	3/8	7.5	11.5	24	17	25
0202000014WNB	1/8	1/2	7.5	14	27	22	25
0202000017WNB	1/4	3/8	11	11.5	27.5	17	25
0202000018WNB	1/4	1/2	11	14	30.5	22	25
020200001ACNB	3/8	1/2	11.5	14	31	22	25
020200001AHNB	1/2	3/4	14	16.5	37.5	27	25
020200001ASNT	3/4	1"	16.5	19	44	34	10

2030

MACHÓN CILÍNDRICO DE REDUCCIÓN - REDUCING NIPPLE (PARALLEL)

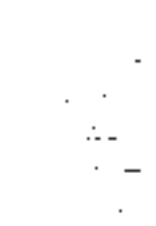

Código Code	A	A1	B	C	L	CH	Conf. Pack.
0203000010WNB	M5	1/8	4	6	14.5	14	50
020300001ATNB	1/8	1/4	6	8	19	17	50
0203000013WNB	1/8	3/8	6	9	20	19	50
0203000017WNB	1/4	3/8	8	9	22	19	50
0203000018WNB	1/4	1/2	8	10	23.5	24	25
020300001ACNB	3/8	1/2	9	10	24.5	24	25
020300001AHNT	1/2	3/4	10	12	27.5	30	25

2040

UNIÓN CÓNICA MACHO - HEMBRA - REDUCER (TAPER)



Código Code	A	A1	B	L	CH	Conf. Pack.
0204000012WNB	1/8	1/8	7.5	20	14	50
020400001ATNB	1/8	1/4	7.5	22	17	50
0204000013WNB	1/8	3/8	7.5	23	22	25
0204000016WNB	1/4	1/4	11	26	17	25
0204000017WNB	1/4	3/8	11	27	22	25
0204000018WNB	1/4	1/2	11	30	26	25
020400001ABNB	3/8	3/8	11.5	27.5	22	25
020400001ACNB	3/8	1/2	11.5	30.5	26	25
020400001AGNB	1/2	1/2	14	33	26	25
020400001AHNB	1/2	3/4	14	35	32	25

2050

UNIÓN CILÍNDRICA MACHO - HEMBRA - REDUCER (PARALLEL)



Código Code	A	A1	B	L	CH	Conf. Pack.
0205000010WNB	M5	1/8	4	14.5	14	50
0205000012WNB	1/8	1/8	6	17	14	50
020500001ATNB	1/8	1/4	6	20.5	17	50
0205000013WNB	1/8	3/8	6	21.5	22	25
0205000016WNB	1/4	1/4	8	22.5	17	25
0205000017WNB	1/4	3/8	8	23.5	22	25
0205000018WNB	1/4	1/2	8	26.5	26	25
020500001ABNB	3/8	3/8	9	24.5	22	25
020500001ACNB	3/8	1/2	9	27.5	26	25
020500001AGNB	1/2	1/2	10	28.5	26	25

2060

MACHÓN CÓNICO ORIENTABLE (3 PIEZAS) - TAPER NIPPLE (3 pieces)

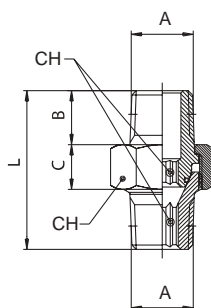
 ARTÍCULO NO NIQUELADO
 ARTICLE NOT NICHEL-PLATED

Código Code	A	B	C	L	CH1	CH2	Conf. Pack.
0206000001	1/8	7.5	8.5	27	15	5	25
0206000002	1/4	11	9.5	33.5	19	6	25
0206000003	3/8	11.5	10	36.5	22	8	10
0206000004	1/2	14	12	45	27	12	10
0206000005	3/4	16.5	17	54	36	14	5
0206000006	1"	19	20	65	46	19	1

 Temperatura mínima / Minimum temperature: -20 °C
 Temperatura máxima / Maximum temperature: +80 °C

 Presión mínima / Minimum pressure: -0.99 bar (-0.099 MPa)
 Presión máxima / Maximum pressure: 15 bar (1.5 MPa)

2070

PROLONGACIÓN CILÍNDRICA - EXTENSION (PARALLEL)



Código Code	A	A1	L	B	CH	Conf. Pack.
020700001BHNB	1/8	1/8	22	6	14	25
020700001BINB	1/8	1/8	42	6	14	25
020700001BLNB	1/4	1/4	35	8	17	25
020700001BMNB	1/4	1/4	51	8	17	25

2080

REDUCCIÓN CÓNICA - REDUCER (TAPER)

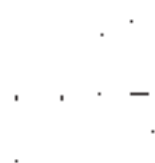

Código Code	A	A1	B	L	CH	Conf. Pack.
0208000015WNB	1/4	1/8	11	16	14	50
0208000019WNB	3/8	1/8	11.5	16.5	17	50
020800001ADNB	1/2	1/8	14	19.5	22	25
020800001AANB	3/8	1/4	11.5	16.5	17	50
020800001AENB	1/2	1/4	14	19.5	22	25
020800001AFNB	1/2	3/8	14	19.5	22	25
020800001ALNB	3/4	3/8	16.5	23.5	27	25
020800001AMNB	3/4	1/2	16.5	23.5	27	25
020800001APNT	1"	1/2	19	27.5	34	10
020800001AQNT	1"	3/4	19	27.5	34	10
020800001ARNT	1"1/4	1/2	22	31	45	10
020800001AUNT	1"1/4	3/4	22	31	45	10
020800001AVNT	1"1/4	1"	22	31	45	10
02080000182NT	1"1/2	1"	22	32	50	5
02080000183NT	2"	1"	24	36	60	5

2090

REDUCCIÓN CILÍNDRICA - REDUCER (PARALLEL)

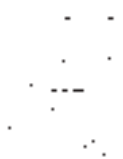

Código Code	A	A1	B	L	CH	Conf. Pack.
0209000010WNT	1/8	M5	6	10.5	14	50
0209000015WNT	1/4	1/8	8	13	17	50
0209000019WNT	3/8	1/8	9	14	19	25
020900001ADNT	1/2	1/8	10	15.5	24	25
020900001AANT	3/8	1/4	9	14	19	25
020900001AENT	1/2	1/4	10	15.5	24	25
020900001AFNT	1/2	3/8	10	15.5	24	25
020900001ALNT	3/4	3/8	12	17.5	30	25
020900001AMNT	3/4	1/2	12	17.5	30	25

2095

REDUCCIÓN CILÍNDRICA - REDUCER (PARALLEL)

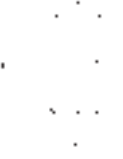

ARTÍCULO NO NIQUELADO
ARTICLE NOT NICHEL-PLATED

Código Code	A	A1	L	Conf. Pack.
0209500015W00	1/4	1/8	8	50
020950001AA00	3/8	1/4	9	50
020950001AF00	1/2	3/8	10	50
020950001AM00	3/4	1/2	14	25
020950001AQ00	1"	3/4	20	25

2096

TUERCA - NUT



Código Code	A	L	CH	Conf. Pack.
02096000102NB	1/8	4.5	14	50
02096000103NB	1/4	5	17	50
02096000104NB	3/8	6	20	50
02096000105NB	1/2	6	24	50

2110

UNIÓN CÓNICA ORIENTABLE - ORIENTING NIPL (TAPER)

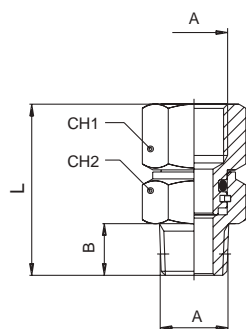

Código Code	A	B	CH1	CH2	L	Conf. Pack.
0211000001	1/8	7.5	13	13	25	50
0211000002	1/4	11	16	15	33	25
0211000003	3/8	11.5	20	17	35.5	25

Temperatura mínima / Minimum temperature: -20 °C
Temperatura máxima / Maximum temperature: +80 °C

Presión mínima / Minimum pressure: -0.99 bar (-0.099 MPa)
Presión máxima / Maximum pressure: 15 bar (1.5 MPa)

2115

UNIÓN CILÍNDRICA ORIENTABLE CON TÓRICA - ORIENTING NIPL (PARALLEL) WITH O-RING

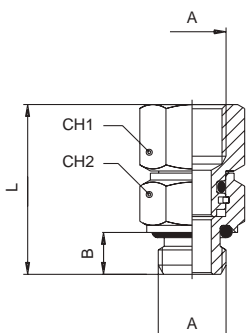

Código Code	A	B	CH1	CH2	L	Conf. Pack.
0211500001	1/8	6	13	13	24.5	50
0211500002	1/4	8	16	16	31	25
0211500003	3/8	9	20	18	34.5	25

Temperatura mínima / Minimum temperature: -20 °C
Temperatura máxima / Maximum temperature: +80 °C

Presión mínima / Minimum pressure: -0.99 bar (-0.099 MPa)
Presión máxima / Maximum pressure: 15 bar (1.5 MPa)

3000

MANGUITO HEMBRA - FEMALE SLEEVE



Código Code	A	L	CH	Conf. Pack.
03000001B5NB	M5	11	8	50
0300000102NB	1/8	15	14	50
0300000103NB	1/4	22	17	25
0300000104NB	3/8	24	22	25
0300000105NB	1/2	30	26	25
0300000107NB	3/4	32	32	25
0300000109NB	1"	46	40	10

3010

MANGUITO DE REDUCCIÓN HEMBRA - FEMALE REDUCING SLEEVE

Código Code	A	A1	L	CH	Conf. Pack.
0301000010WNB	M5	1/8	13	14	50
030100001ATNB	1/8	1/4	19	17	50
0301000013WNB	1/8	3/8	20	22	25
0301000014WNB	1/8	1/2	24	24	25
0301000017WNB	1/4	3/8	23	22	25
0301000018WNB	1/4	1/2	25	24	25
030100001ACNB	3/8	1/2	27.5	24	25
030100001AHNB	1/2	3/4	30	30	25
030100001AINB	1/2	1"	39	40	10
030100001ASNB	3/4	1"	41	40	10

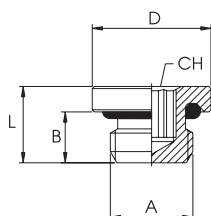
3015

TAPÓN MACHO CILÍNDRICO HEXÁGONO INTERIOR CON TÓRICA - MALE PLUG (PARALLEL) WITH EXAGON EMBEDDED AND O-RING

Código Code	A	B	L	D	CH	Conf. Pack.
0301500005	M5	4	6	8	2	50
0301500001	1/8	6	8.5	14	5	50
0301500002	1/4	8	11	17	6	50
0301500003	3/8	9	12.5	20	8	25
0301500004	1/2	10	13.5	25	10	25

Temperatura mínima / Minimum temperature: -20 °C
 Temperatura máxima / Maximum temperature: +80 °C

Presión mínima / Minimum pressure: -0.99 bar (-0.099 MPa)
 Presión máxima / Maximum pressure: 15 bar (1.5 MPa)

3015V

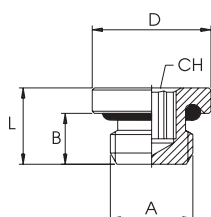
TAPÓN MACHO CILÍNDRICO HEXÁGONO INTERIOR CON TÓRICA FKM - MALE PLUG (PARALLEL) WITH EXAGON EMBEDDED AND FKM O-RING

Código Code	A	B	L	D	CH	Conf. Pack.
03015V0005	M5	4	6	8	2	50
03015V0001	1/8	6	8.5	14	5	50
03015V0002	1/4	8	11	17	6	50
03015V0003	3/8	9	12.5	20	8	25
03015V0004	1/2	10	13.5	25	10	25

Temperatura mínima / Minimum temperature: -20 °C
 Temperatura máxima / Maximum temperature: +200 °C

Presión mínima / Minimum pressure: -0.99 bar (-0.099 MPa)
 Presión máxima / Maximum pressure: 15 bar (1.5 MPa)

3020

TAPÓN MACHO CILÍNDRICO - MALE PLUG (PARALLEL)

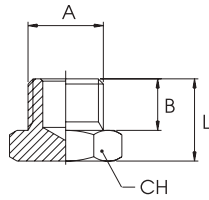

Código Code	A	B	L	CH	Conf. Pack.
030200001B5NB	M5	4.5	8	8	50
03020000102NB	1/8	6.5	10	14	50
03020000103NB	1/4	9	13	17	50
03020000104NB	3/8	9.5	13.5	19	25
03020000105NB	1/2	10	14.5	24	25
03020000107NB	3/4	11	16	30	25
03020000109NB	1"	12	17	40	10

3025

TAPÓN MACHO CÓNICO HEXÁGONO INTERIOR - MALE PLUG (TAPER) WITH HEXAGON EMBEDDED



Código Code	A	B	H	CH	Conf. Pack.
03025000102NB	1/8	7.5	5	5	50
03025000103NB	1/4	10	7	6	50
03025000104NB	3/8	11	7	8	50
03025000105NB	1/2	13	8	10	25

3026

TAPÓN MACHO CILÍNDRICO HEXÁGONO INTERIOR - MALE PLUG (PARALLEL) WITH HEXAGON EMBEDDED



Código Code	A	B	D	E	H	CH	Conf. Pack.
03026000102NB	1/8	8	8	2	5	5	50
03026000103NB	1/4	11	11	3	7	6	50
03026000104NB	3/8	12.5	14.5	3.5	8.5	8	50
03026000105NB	1/2	14	18	4	10	10	25
03026000107NB	3/4	14	21.5	3	10	12	25

3030

TAPÓN HEMBRA - FEMALE PLUG



Código Code	A	B	L	CH	Conf. Pack.
03030000102NB	1/8	7.5	11	12	50
03030000103NB	1/4	11	19	14	50
03030000104NB	3/8	11.5	20	17	25
03030000105NB	1/2	14	22	19	25

3040

ESPIGA MACHO CÓNICA - MALE HOSE ADAPTER (TAPER)



Código Code	A	A1	B	C	L	CH	Conf. Pack.
030400001BSNB	6	1/8	19.5	7.5	32	12	50
030400001BTNB	6	1/4	19.5	11	35.5	14	50
030400001BZNB	7	1/8	19.5	7.5	32	12	50
030400001BXNB	7	1/4	19.5	11	35.5	14	50
030400001BYNB	8	1/8	19.5	7.5	32	12	50
030400001BJNB	8	1/4	19.5	11	35.5	14	50
030400001CANB	9	1/8	19.5	7.5	32	12	50
030400001CBNB	9	1/4	19.5	11	35.5	14	50
030400001CCNB	9	3/8	19.5	11.5	36	17	25
030400001CDNB	9	1/2	19.5	14	39	22	25
030400001CENB	10	1/8	19.5	7.5	32	12	50
030400001CFNB	10	1/4	19.5	11	35.5	14	50
030400001CGNB	10	3/8	19.5	11.5	36	17	25
030400001CHNB	10	1/2	19.5	14	39	22	25
030400001CINB	12	1/4	19.5	11	35.5	14	50
030400001CLNB	12	3/8	19.5	11.5	36	17	25
030400001CMNB	12	1/2	19.5	14	39	22	25
030400001CNNB	14	3/8	19.5	11.5	36	17	25
030400001DBNB	14	1/2	19.5	14	39	22	25
030400001CQNB	16	3/8	19.5	11.5	36	17	25
030400001CRNB	16	1/2	19.5	14	39	22	25
030400001CSNB	16	3/4	19.5	16.5	43.5	27	25
030400001CTNB	17	3/8	19.5	11.5	36	18	25
030400001CUNB	17	1/2	19.5	14	39	22	25
030400001CVNB	18	3/8	19.5	11.5	36	19	25
030400001CZNB	18	1/2	19.5	14	39	22	25
030400001CXNB	18	3/4	19.5	16.5	43.5	27	25
030400001CYNB	20	3/8	19.5	11.5	36	21	25
030400001C1NB	20	1/2	30	14	49.5	22	25
030400001R8NB	20	3/4	30	13.5	50.5	27	25
030400001C4NB	25	3/4	30	14.5	51.5	27	25
030400001DLNB	25	1"	30	16	53.5	34	10

3044

ESPIGA MACHO CILÍNDRICA CON TÓRICA - MALE HOSE ADAPTER (PARALLEL) WITH O - RING

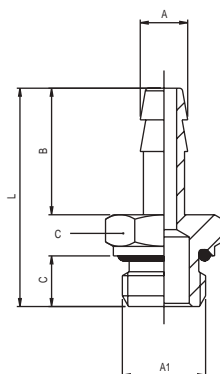

Código Code	A	A1	B	C	L	CH	Conf. Pack.
0304400001	4.5	M5	15	4	24	8	50
0304400002	7	1/8	20	6	31	13	50
0304400003	7	1/4	20	8	34.5	16	50
0304400004	8	1/8	20	6	31	13	50
0304400005	8	1/4	20	8	34.5	16	50
0304400006	9	1/8	20	6	31	13	50
0304400007	9	1/4	20	8	34.5	16	50
0304400008	9	3/8	20	9	35.5	19	25
0304400009	12	1/4	20	8	34.5	16	25
0304400010	12	3/8	20	9	35.5	19	25
0304400011	12	1/2	22	10	39.5	24	25
0304400012	17	3/8	24	9	39.5	19	25
0304400013	17	1/2	24	10	41.5	24	25

Temperatura mínima / Minimum temperature: -20 °C
 Temperatura máxima / Maximum temperature: +80 °C

Presión mínima / Minimum pressure: -0.99 bar (-0.099 MPa)
 Presión máxima / Maximum pressure: +15 bar (1.5 MPa)

3045

ESPIGA MACHO CILÍNDRICA - MALE HOSE ADAPTER (PARALLEL)

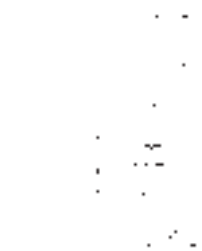

Código Code	A	A1	B	C	L	CH	Conf. Pack.
0304500018SNB	4.5	M5	15	4	23	8	50
030450001BZNB	7	1/8	20	6	30	14	50
030450001BXNB	7	1/4	20	8	33	17	50
030450001BYNB	8	1/8	20	6	30	14	50
030450001BJNB	8	1/4	20	8	33	17	50
030450001CANB	9	1/8	20	6	30	14	50
030450001CBNB	9	1/4	20	8	33	17	50
030450001CCNB	9	3/8	20	9	34	19	25
030450001CINB	12	1/4	20	8	33	17	25
030450001CLNB	12	3/8	20	9	34	19	25
030450001CMNB	12	1/2	22	10	37.5	24	25
030450001CTNB	17	3/8	24	9	38	19	25
030450001CUNB	17	1/2	24	10	39.5	24	25

3050

ESPIGA HEMBRA - FEMALE HOSE ADAPTER



Código Code	A	A1	B	C	L	CH	Conf. Pack.
030500001BSNB	6	1/8	19.5	8.5	30	14	50
030500001BZNB	7	1/8	19.5	8.5	30	14	50
030500001BXNB	7	1/4	19.5	11	32.5	17	50
030500001BJNB	8	1/4	19.5	11	32.5	17	50
030500001CBNB	9	1/4	19.5	11	32.5	17	50
030500001CCNB	9	3/8	19.5	11.5	33.5	20	25
030500001CGNB	10	3/8	19.5	11.5	33.5	20	25
030500001CLNB	12	3/8	19.5	11.5	33.5	20	25
030500001CMNB	12	1/2	19.5	14.5	37.5	24	25

3055

ESPIGA A L MACHO - MALE HOSE ADAPTER ELBOW

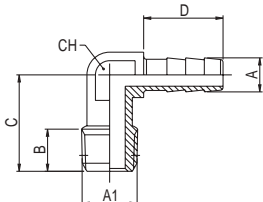

Código Code	A	A1	B	C	D	CH	Conf. Pack.
030550001BSNB	6	1/8	7.5	17	14	11	50
030550001BTNB	6	1/4	11	22	14	11	50
030550001BZNB	7	1/8	7.5	17	14	11	25
030550001BXNB	7	1/4	11	22	14	11	25
030550001CBNB	9	1/4	11	22	14	11	25

3060

RACOR PASATABIQUES - BULKHEAD CONNECTOR



Código Code	A	B	C MAX	D	E	CH1	CH2	Conf. Pack.
0306000001	M5	M10x1	7	10.5	3.5	14	14	25
0306000002	1/8	M16x1.5	10	14	4	22	19	25
0306000003	1/4	M20x1.5	16	21	4	27	24	25
0306000004	3/8	M26x1.5	15	21	5	32	30	25
0306000005	1/2	M28x1.5	21	27	6	36	32	10

1704

TUERCA PASATABIQUES - NUT

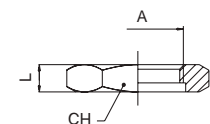

Código Code	A	CH	L	Conf. Pack.
017040001C8NB	M10x1	14	4	50
017040001E3NB	M16x1.5	22	5	50
017040001F2NB	M20x1.5	27	6	50
017040001OVB	M26x1.5	32	7	50
017040001H1NB	M28x1.5	36	7	50

4000

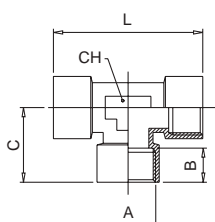
RACOR A T HEMBRA - FEMALE TEE

Código Code	A	B	C	L	CH	Conf. Pack.
0400000102NB	1/8	8.5	19.5	39	12	25
0400000103NB	1/4	11	24.5	49	13	25
0400000104NB	3/8	12	27	54	16	25
0400000105NB	1/2	15	32	64	20	10
0400000107NT	3/4	16.5	36.5	73	27	10
0400000109NT	1"	19	45	90	30	5

4010

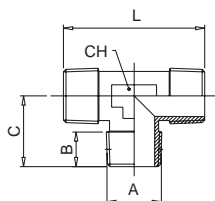
RACOR A T MACHO - MALE TEE

Código Code	A	B	C	L	CH	Conf. Pack.
04010000102NB	1/8	8	17.5	35	12	25
04010000103NB	1/4	11	23	46	13	25
04010000104NB	3/8	11.5	25.5	51.5	16	25
04010000105NB	1/2	14	29.5	59	20	10
04010000107NT	3/4	14.5	32	64	27	10
04010000109NT	1"	16.8	39	78	30	5

4020

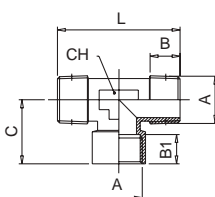
RACOR A T HEMBRA CENTRAL - CENTRE LEG FEMALE TEE

Código Code	A	B	B1	C	L	CH	Conf. Pack.
04020000102NB	1/8	8	8.5	19.5	35	12	25
04020000103NB	1/4	11	11	24.5	46	13	25
04020000104NB	3/8	11.5	12	27	51	16	25
04020000105NB	1/2	14	15	32	59	20	10
04020000107NT	3/4	14.5	16.5	36.5	64	27	10
04020000109NT	1"	16.8	19	45	78	30	5

4030

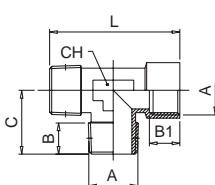
RACOR A T HEMBRA LATERAL - OFF SET FEMALE TEE

Código Code	A	B	B1	C	L	CH	Conf. Pack.
04030000102NB	1/8	8	8.5	17.5	37	12	25
04030000103NB	1/4	11	11	23	47.5	13	25
04030000104NB	3/8	11.5	12	25.5	52.5	16	25
04030000105NB	1/2	14	15	29.5	61.5	20	10
04030000107NT	3/4	14.5	16.5	32	68.5	27	10
04030000109NT	1"	16.8	19	39	84	30	5

4040

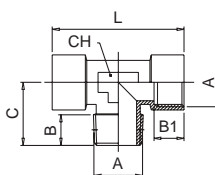
RACOR A T MACHO CENTRAL - CENTRE LEG MALE TEE

Código Code	A	B	B1	C	L	CH	Conf. Pack.
04040000102NB	1/8	8	8.5	17.5	39	12	25
04040000103NB	1/4	11	11	23	49	13	25
04040000104NB	3/8	11.5	12	25.5	54	16	25
04040000105NB	1/2	14	15	29.5	64	20	10
04040000107NT	3/4	14.5	16.5	32	73	27	10
04040000109NT	1"	16.8	19	39	90	30	5

4050

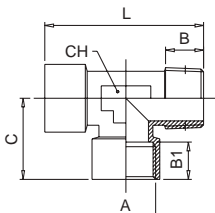
RACOR A T MACHO LATERAL - OFF SET MALE TEE

Código Code	A	B	B1	C	L	CH	Conf. Pack.
04050000102NB	1/8	8	8.5	19.5	37	12	25
04050000103NB	1/4	11	11	24.5	47.5	13	25
04050000104NB	3/8	11.5	12	27	52.5	16	25
04050000105NB	1/2	14	15	32	61.5	20	10
04050000107NT	3/4	14.5	16.5	36.5	68.5	27	10
04050000109NT	1"	16.8	19	45	84	30	5

5000

RACOR A L MACHO - MALE ELBOW

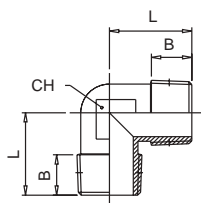

Código Code	A	B	L	CH	Conf. Pack.
0500000102NB	1/8	7.5	18	11	50
0500000103NB	1/4	11	24	13	25
0500000104NB	3/8	12	27	17	25
0500000105NB	1/2	14	29.5	20	25
0500000107NT	3/4	14.5	32	27	10
0500000109NT	1"	16.8	39	30	5

5010

RACOR A L HEMBRA - FEMALE ELBOW

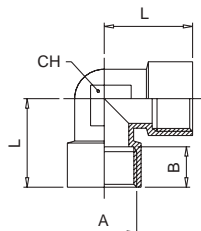

Código Code	A	B	L	CH	Conf. Pack.
05010000102NB	1/8	8.5	21	11	50
05010000103NB	1/4	11	25.5	13	25
05010000104NB	3/8	11.5	28	17	25
05010000105NB	1/2	15	32	20	25
05010000107NT	3/4	16.5	36.5	27	10
05010000109NT	1"	19	45	30	5

5020

RACOR A L MACHO - HEMBRA - MALE-FEMALE ELBOW

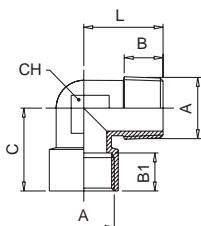

Código Code	A	B	B1	C	L	CH	Conf. Pack.
05020000102NB	1/8	7.5	8.5	21	18	11	50
05020000103NB	1/4	11	11	25.5	24	13	25
05020000104NB	3/8	11.5	12	28	27	17	25
05020000105NB	1/2	14	15	32	29.5	20	25
05020000107NT	3/4	14.5	16.5	36.5	32	27	10
05020000109NT	1"	16	19	45	39	30	5

5050

RACOR A L FIJACIÓN 90° CON SOPORTE - FEMALE BRACKET FITTING 90°

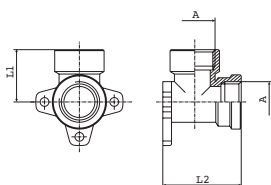

Código Code	A	L1	L2	Conf. Pack.
05050000105NB	1/2	27	40.5	10

6000

DERIVACIÓN A Y 90° MACHO - MALE Y 90°

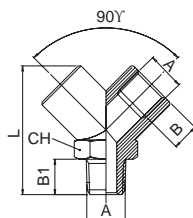

Código Code	A	B	B1	L	CH	Conf. Pack.
06000000102NB	1/8	8.5	9	33	14	25
06000000103NB	1/4	11	11	37	17	25
06000000104NB	3/8	11.5	12.5	46	22	20
06000000105NB	1/2	14	16.5	58	26	10

6010

DERIVACIÓN A Y 90° HEMBRA - FEMALE Y 90°

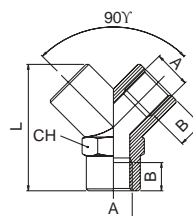

Código Code	A	B	L	CH	Conf. Pack.
06010000102NB	1/8	8.5	33	14	25
06010000103NB	1/4	11	37	17	25
06010000104NB	3/8	11.5	46	22	20
06010000105NB	1/2	14	58	26	10

6020

RACOR A CRUZ HEMBRA - FEMALE EQUAL CROSS

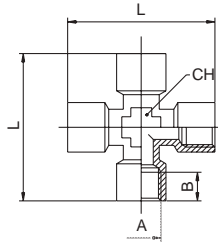

Código Code	A	B	L	CH	Conf. Pack.
06020000102NB	1/8	8.5	39	11	25
06020000103NB	1/4	11	50	13	25
06020000104NB	3/8	12	56	17	10
06020000105NB	1/2	15	64	20	10

6025

RACOR A CRUZ MACHO - HEMBRA - MALE-FEMALE EQUAL CROSS

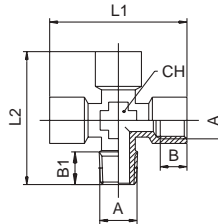

Código Code	A	B	B1	L1	L2	CH	Conf. Pack.
06025000102NB	1/8	8.5	8	39	37	11	25
06025000103NB	1/4	11	11	50	48.5	13	25
06025000104NB	3/8	12	11.5	56	54	17	10
06025000105NB	1/2	15	14	64	61	20	10

6030

RACOR A CRUZ MACHO - MALE EQUAL CROSS

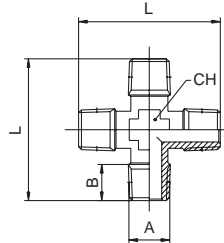

Código Code	A	B	L	CH	Conf. Pack.
06030000102NB	1/8	8	35	11	25
06030000103NB	1/4	11	47	13	25
06030000104NB	3/8	11.5	52	17	10
06030000105NB	1/2	14	58	20	10

6040

RACOR A CRUZ EN ALUMINIO - ALUMINIUM TEE CROSS



Código Code	A	L	H	B	C	Conf. Pack.
06040001102AG	1/8	25	15	4.3	4.5	25
06040001103AG	1/4	40	20	6.5	5.5	10
06040001104AG	3/8	50	25	7.5	5.5	5
06040001105AG	1/2	50	30	7.5	5.5	5

6047

REGLETA SIMPLE EN ALUMINIO - ALUMINIUM DISTRIBUTION MANIFOLD

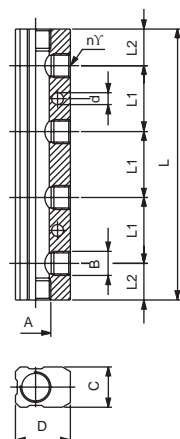

Código Code	A	B	n°	C	D	L1	L2	L	d	Conf. Pack.
060470011AJAG	1/4	1/8	2	18	24	30	17.5	65	4.5	5
060470011AKAG	1/4	1/8	3	18	24	30	17.5	95	4.5	5
060470011AWAG	1/4	1/8	4	18	24	30	17.5	125	4.5	5
060470011BAAG	1/4	1/8	5	18	24	30	17.5	155	4.5	5
060470011BBAG	1/4	1/8	6	18	24	30	17.5	185	4.5	5
060470011BCAG	3/8	1/4	2	22	30	36	20	76	5.5	5
060470011BDAG	3/8	1/4	3	22	30	36	20	112	5.5	5
060470011BEAG	3/8	1/4	4	22	30	36	20	148	5.5	5
060470011BFAG	3/8	1/4	5	22	30	36	20	184	5.5	5
060470011BGAG	3/8	1/4	6	22	30	36	20	220	5.5	5
060470011ESAG	1/2	3/8	2	26	35	40	25	90	5.5	5
060470011ETAG	1/2	3/8	3	26	35	40	25	130	5.5	5
060470011EUAG	1/2	3/8	4	26	35	40	25	170	5.5	5
060470011EVAG	1/2	3/8	5	26	35	40	25	210	5.5	5
060470011EZAG	1/2	3/8	6	26	35	40	25	250	5.5	5

6048

REGLETA DOBLE EN ALUMINIO - ALUMINIUM DOUBLE DISTRIBUTION MANIFOLD

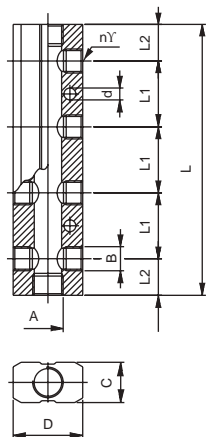

Código Code	A	B	n°	C	D	L1	L2	L	d	Conf. Pack.
060480011AJAG	1/4	1/8	2	18	30	30	17.5	65	4.5	5
060480011AKAG	1/4	1/8	3	18	30	30	17.5	95	4.5	5
060480011AWAG	1/4	1/8	4	18	30	30	17.5	125	4.5	5
060480011BAAG	1/4	1/8	5	18	30	30	17.5	155	4.5	5
060480011BBAG	1/4	1/8	6	18	30	30	17.5	185	4.5	5
060480011BCAG	3/8	1/4	2	22	38	36	20	76	5.5	5
060480011BDAG	3/8	1/4	3	22	38	36	20	112	5.5	5
060480011BEAG	3/8	1/4	4	22	38	36	20	148	5.5	5
060480011BFAG	3/8	1/4	5	22	38	36	20	184	5.5	5
060480011BGAG	3/8	1/4	6	22	38	36	20	220	5.5	5
060480011ESAG	1/2	3/8	2	26	44	40	25	90	5.5	5
060480011ETAG	1/2	3/8	3	26	44	40	25	130	5.5	5
060480011EUAG	1/2	3/8	4	26	44	40	25	170	5.5	5
060480011EVAG	1/2	3/8	5	26	44	40	25	210	5.5	5
060480011EZAG	1/2	3/8	6	26	44	40	25	250	5.5	5

6070

RACOR A L MACHO HEMBRA - MALE-FEMALE ELBOW FITTING

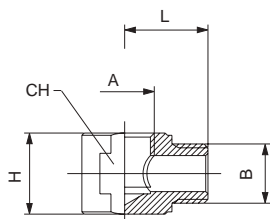

Código Code	A	B	H	L	CH	Conf. Pack.
0607000012WNB	1/8	1/8	13	15	13	25
0607000016WNB	1/4	1/4	18	19	18	25

6080

RACOR A T MACHO - HEMBRA - HEMBRA - MALE-FEMALE-FEMALE TEE FITTING

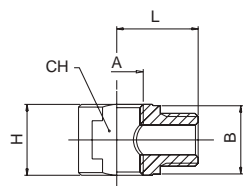

Código Code	A	B	H	L	CH	Conf. Pack.
0608000012WNT	1/8	1/8	13	15	13	25
0608000016WNT	1/4	1/4	18	18.5	18	25

6090

ANILLO ORIENTABLE HEMBRA - FEMALE SINGLE BANJO BODY

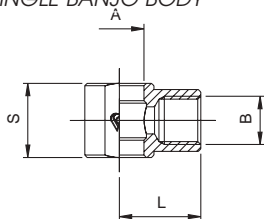

Código Code	B	A	L	S	Conf. Pack.
06090000102NB	1/8	10	16.5	15	25
06090000103NB	1/4	13	22	17	25
06090000104NB	3/8	16.7	26	20	25

7000

SILENCIADOR BRONCE – SILENCER BRONZE

dB = Nivel de ruido en (dB) a 6 bar
 Noise level in (dB) at 6 bar

CARACTERÍSTICAS TÉCNICAS / TECHNICAL CHARACTERISTICS

Presión máxima / maximum pressure: 10 bar
 Temperatura mínima / minimum temperature: -10°C
 Temperatura máxima / maximum temperature: +80°C
 Grado de filtración / filtration threshold: 50 µm

Código Code	A	F	H	CH	dB	Conf. Pack.
070000001	1/8	4.5	12.5	21	81	25
070000002	1/4	6	15	25	83	25
070000003	3/8	8.5	19	34.5	87	25
070000004	1/2	8	23	43	90	25
070000005	3/4	9	30	50	92 a 4 Bar	25
070000006	1"	11	37	60.5	92 a 4 Bar	10

7010

SILENCIADOR – SILENCER

dB = Nivel de ruido en (dB) a 6 bar
 Noise level in (dB) at 6 bar

CARACTERÍSTICAS TÉCNICAS / TECHNICAL CHARACTERISTICS

Presión máxima / maximum pressure: 12 bar
 Temperatura mínima / minimum temperature: -10°C
 Temperatura máxima / maximum temperature: +80°C
 Grado de filtración / filtration threshold: 100 µm

Código Code	A	F	H	CH	dB	Conf. Pack.
070100001	1/8	6	14	13	73	25
070100002	1/4	7	17	16	74	25
070100003	3/8	8	18	19	85	25
070100004	1/2	10	20	24	89	25
070100005	3/4	10	23	30	90	25

7020

SILENCIADOR – SILENCER

dB = Nivel de ruido en (dB) a 6 bar
 Noise level in (dB) at 6 bar

CARACTERÍSTICAS TÉCNICAS / Technical characteristics

Presión máxima / maximum pressure: 12 bar
 Temperatura mínima / minimum temperature: -10°C
 Temperatura máxima / maximum temperature: +80°C
 Grado de filtración / filtration threshold: 100 µm

Código Code	A	F	H	CH	dB	Conf. Pack.
070200001	M5	4	8	8	-	25
070200002	1/8	6	15	13	74	25
070200003	1/4	7	18	16	72	25
070200004	3/8	8	20	19	88	25
070200005	1/2	10	22	24	90	25
070200006	3/4	10	26	30	90	25
070200007	1"	12	28	36	92	10

7030

SILENCIADOR - SILENCER



dB = Abatimiento acústico (dB) a 6 bar
Acoustic fading (dB) at 6 bar

CARACTERÍSTICAS TÉCNICAS / TECHNICAL CHARACTERISTICS

Presión máxima / maximum pressure: 10 bar
 Temperatura mínima / minimum temperature: -10°C
 Temperatura máxima / maximum temperature: +80°C
 Grado de filtración / filtration threshold: 50 µm

Código Code	A	F	H	CH	dB	Conf. Pack.
0703000001	M5	4	17	8	-	25
0703000002	1/8	6	29	13	-	25
0703000003	1/4	7	32	16	-	25
0703000004	3/8	8	40	19	-	25
0703000005	1/2	9	45	24	-	25
0703000006	3/4	10	56	30	-	10
0703000007	1"	12	66	36	-	10

7040

SILENCIADOR - SILENCER



dB = Abatimiento acústico (dB) a 6 bar
Acoustic fading (dB) at 6 bar

CARACTERÍSTICAS TÉCNICAS / TECHNICAL CHARACTERISTICS

Presión máxima / maximum pressure: 12 bar
 Temperatura mínima / minimum temperature: -10°C
 Temperatura máxima / maximum temperature: +80°C
 Grado de filtración / filtration threshold: 36 µm

Código Code	A	F	H	CH	dB	Conf. Pack.
0704000001	1/8	6	44	13	76	25
0704000002	1/4	7	50	16	75	25
0704000003	3/8	8	54	19	88	25
0704000004	1/2	9	67	24	89	10
0704000005	3/4	9	65	30	-	10

7050

SILENCIADOR - SILENCER



dB = Abatimiento acústico (dB) a 6 bar
Acoustic fading (dB) at 6 bar

CARACTERÍSTICAS TÉCNICAS / TECHNICAL CHARACTERISTICS

Presión máxima / maximum pressure: 12 bar
 Temperatura mínima / minimum temperature: -10°C
 Temperatura máxima / maximum temperature: +80°C
 Grado de filtración / filtration threshold: 100 µm

Código Code	A	F	Hmin	Hmax	CH	dB	Conf. Pack.
0705000001	1/8	6	26	28	13	72	25
0705000002	1/4	8	30	32	15	73	25
0705000003	3/8	10	35	38	22	84	25
0705000004	1/2	11	37	40	22	88	25

7060

SILENCIADOR - SILENCER



dB = Abatimiento acústico (dB) a 6 bar
Acustic fading (dB) at 6 bar

CARACTERÍSTICAS TÉCNICAS / TECHNICAL CHARACTERISTICS

Presión máxima / maximum pressure:	10 bar
Temperatura mínima / minimum temperature:	-10°C
Temperatura máxima / maximum temperature:	+80°C
Grado de filtración / filtration threshold:	50 µm

Código Code	Misura/Size	A	F	B	H	dB	Conf. Pack.
070600002	4	3.5	8	8	25.5	-	25
070600003	6	5	10	8	26	-	25

7070

SILENCIADOR DE RESINA ACETÁLICA CON MATERIAL PLÁSTICO FONOABSORBENTE
SILENCER MADE IN ACETALIC RESIN WITH PLASTIC SOUNDPROOFING MATERIAL

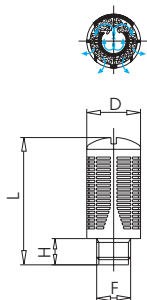

dB = Abatimiento acústico (dB) a 6 bar
Acustic fading (dB) at 6 bar

CARACTERÍSTICAS TÉCNICAS / TECHNICAL CHARACTERISTICS

Presión máxima / maximum pressure:	6 bar
Temperatura mínima / minimum temperature:	-10°C
Temperatura máxima / maximum temperature:	+50°C

Código Code	F	H	D	L	dB	Conf. Pack.
070700001	1/8	6	15	32.5	87	25
070700002	1/4	8	19.5	43	84	25
070700003	3/8	11	24.5	58	90	25
070700004	1/2	11	24.5	58	90	10
070700005	3/4	18	48	115	91	5
070700006	1"	18	48	115	90	5

7080

SILENCIADOR EN PA66 Y FILTRO - SILENCER MADE IN PA66 WITH FELT

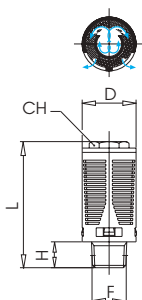

dB = Abatimiento acústico (dB) a 6 bar
Acustic fading (dB) at 6 bar

CARACTERÍSTICAS TÉCNICAS / TECHNICAL CHARACTERISTICS

Presión máxima / maximum pressure:	6 bar
Temperatura mínima / minimum temperature:	-10°C
Temperatura máxima / maximum temperature:	+70°C

Código Code	F	H	D	L	CH	dB	Conf. Pack.
070800001	1/8	6	16	34	2	87	25
070800002	1/4	8	19	44	12	90	25
070800003	3/8	10	24	56	17	92	25
070800004	1/2	10	24	56	17	92	10
070800005	3/4	18	48	115	-	-	5
070800006	1"	18	48	115	-	-	5

7100

SILENCIADOR EN POLIETILENO - POROUS POLYETHYLENE SILENCER

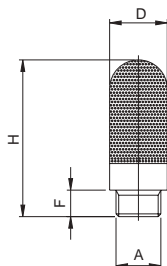

CARACTERÍSTICAS TÉCNICAS / TECHNICAL CHARACTERISTICS

Presión máxima / maximum pressure: 10 bar
 Temperatura mínima / minimum temperature: -15°C
 Temperatura máxima / maximum temperature: +100°C
 Grado de filtración / filtration threshold: 75 µm

Código Code	A	F	H	D	Conf. Pack.
071000001	M5	4	23	6.5	25
071000002	1/8	6	34	12.5	25
071000003	1/4	7	42.5	15.5	25
071000004	3/8	11.5	67.5	18.5	25
071000005	1/2	11	78	23.5	10
071000006	3/4	15.5	140	38.5	5
071000007	1"	19.5	160	49	5

El diagrama muestra la distribución de la frecuencia del sonido de una muestra de aire a una presión de 6 bar de un típico escape de una válvula neumática de 1/2". La zona crítica entre 1 y 4 KHz, es la donde el oído humano es más sensible y donde los efectos psicológicos a los altos niveles de sonido son más dañinos. Como se observa en el diagrama la atenuación del sonido es de cerca de 20-25 dB a una presión de 6 bar.

In the diagram is shown the frequency distribution of the sound energy in an 6 bar air jet from a typical 1/2" control valve exhaust port. The critical region is that between 1 and 4 KHz, the range where psychological effects at high noise levels are most damaging. Sound reduction for this silencer is approx mately 20-25 dB at 6 bar working pressure.

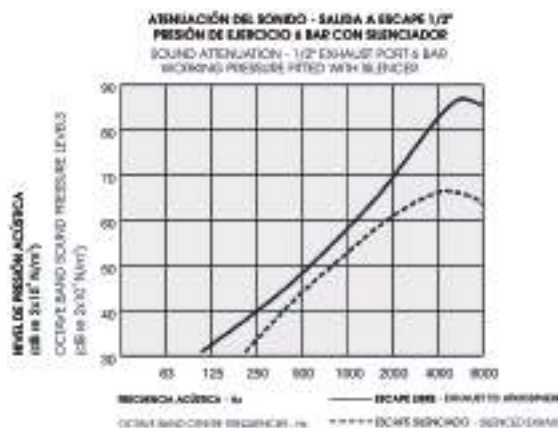

7110

SILENCIADOR EN POLIETILENO CON REGULACIÓN DE ESCAPE - POROUS POLYETHYLENE RESTRICTOR SILENCER

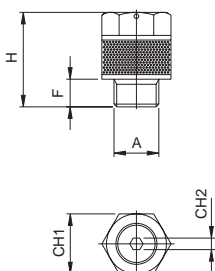

CARACTERÍSTICAS TÉCNICAS / TECHNICAL CHARACTERISTICS

Presión máxima / maximum pressure: 10 bar
 Temperatura mínima / minimum temperature: -15°C
 Temperatura máxima / maximum temperature: +100°C
 Grado de filtración / filtration threshold: 75 µm

Código Code	A	F	H	CH1	CH2	Conf. Pack.
071100001	M5	5	16	8	1.5	25
071100002	1/8	6	20.5	13	2.5	25
071100003	1/4	7	29	15	4	25
071100004	3/8	8	38	20	6	25
071100005	1/2	10	50	25	8	10

La unión de una curada y fácil regulación con los elementos del silenciador poroso en polietileno aumentan las prestaciones de este artículo, las características del cual son representadas en el gráfico adjunto.

The combination of accurate and easy adjustment with the porous polyethylene silencing increase the performance of this article, which characteristics are shown in the following diagram.



7120

SILENCIADOR DE PASTILLA CON CORTE PARA DESTORNILLADOR - PAD SILENCER WITH SLOT FOR SCREWDRIVER

CARACTERÍSTICAS TÉCNICAS / TECHNICAL CHARACTERISTICS

Presión máxima / maximum pressure:	10 bar
Temperaturas / temperature:	-10°C / +80°C
Grado de filtración / filtration threshold:	120 µm

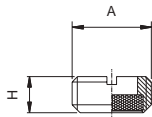

Código Code	A	H	Conf. Pack.
071200001	1/8	4	25
071200002	1/4	6	25
071200003	3/8	6	25
071200004	1/2	9	25
071200005	3/4	10	10
071200006	1"	10	10

7130

SILENCIADOR DE PASTILLA FILTRANTE CÓNICO CON CORTE PARA DESTORNILLADOR

SILENCER WITH FILTERING PAD - (TAPER) WITH SLOT FOR SCREWDRIVER

CARACTERÍSTICAS TÉCNICAS / TECHNICAL CHARACTERISTICS

Presión máxima / maximum pressure:	10 bar
Temperaturas / temperature:	-10°C / +80°C
Grado de filtración / filtration threshold:	50 µm

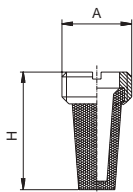

Código Code	A	H	Conf. Pack.
071300001	1/8	15	25
071300002	1/4	18	25
071300003	3/8	21	25
071300004	1/2	27	25
071300005	3/4	36	10
071300006	1"	46	10

7140

SILENCIADOR INTEGRAL CON CORTE PARA DESTORNILLADOR - INTEGRAL SILENCER WITH SLOT FOR SCREWDRIVER

CARACTERÍSTICAS TÉCNICAS / TECHNICAL CHARACTERISTICS

Presión máxima / maximum pressure:	10 bar
Temperaturas / temperature:	-10°C / +80°C
Grado de filtración / filtration threshold:	50 µm

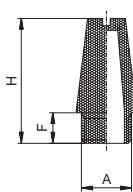

Código Code	A	H	F	Conf. Pack.
071400001	1/8	21	5.5	25
071400002	1/4	27	8.5	25
071400003	3/8	36	11	25
071400004	1/2	44	11	25
071400005	3/4	63	13	10
071400006	1"	75	15	10

7150

SILENCIADOR INTEGRAL CON LLAVE HEXAGONAL - INTEGRAL SILENCER WITH HEXAGONAL WRENCH

CARACTERÍSTICAS TÉCNICAS / TECHNICAL CHARACTERISTICS

Presión máxima / maximum pressure:	10 bar
Temperaturas / temperature:	-10°C / +80°C
Grado de filtración / filtration threshold:	76 µm

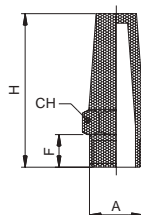

Código Code	A	H	F	CH	Conf. Pack.
071500001	1/8	28	6	13	25
071500002	1/4	31.4	8	17	25
071500003	3/8	36	10	22	25
071500004	1/2	44	12	27	25
071500005	3/4	54	14	32	10
071500006	1"	66	16	41	10



Serie 1800

**RACORDAJE Y ACCESORIOS CON
CONEXIÓN A BAYONETA**

*FIXTURES AND FITTINGS
WITH BAYONET CONNECTION*

Características técnicas / Technical Characteristics

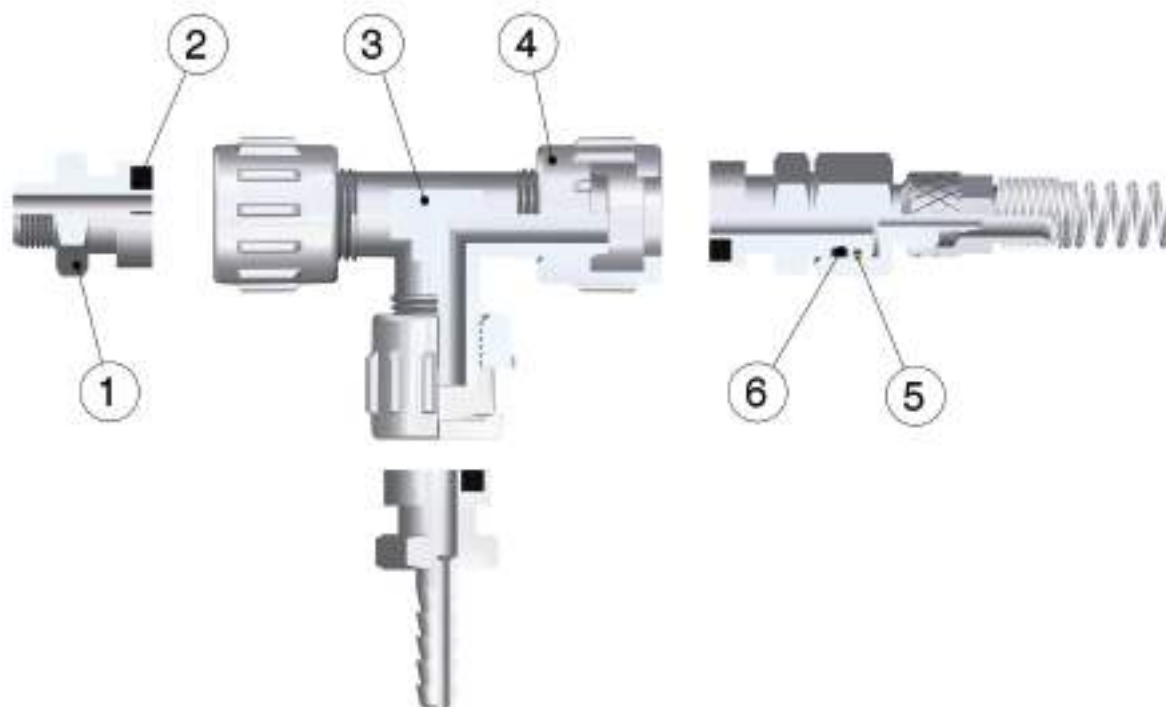

Materiales y componentes / Component Parts and Materials

- 1 Bayoneta en latón niquelado
- 2 Junta en NBR 90
- 3 Cuerpo en latón niquelado
- 4 Tuerca en níquel plateado zamac
- 5 Seeger en bronce
- 6 Junta o-ring en NBR 70

- 1 Nickel-plated brass Bayonet
- 2 NBR 90 Seals
- 3 Nickel-plated brass Body
- 4 Nickel-plated zamac Milled Nut
- 5 Bronze Seeger
- 6 NBR 70 o-ring seal

Presiones / Pressures

Los valores de presión así como los valores de temperatura dependen del tipo de tubo usado, por este motivo dichos valores vendrán determinados por las características del tubo.

The working pressure and working temperatures depend on which type of tube is used, for this reason, the values must be determined in accordance with the tube's features.

Presión mínima / Minimum pressure: **-0.99 bar** (-0.099 MPa)

Presión máxima / Maximum pressure: **15 bar** (1.5 MPa)

Temperatura / Temperatures

Temperatura mínima / Minimum temperature: **-18 °C**

Temperatura máxima / Maximum temperature: **+70 °C**

Roscas / Threads

Gas cilíndrica conforme ISO 228 Clase A / Parallel gas in conformity with ISO 228 Class A.
Métrica conforme ISO R/262 / Metric in conformity with ISO R/262.

Tubos de conexión / Connection Tubes

Tubos en material plástico:

PA6, PA11, PA12, Polietileno, *Poliuretano, PVC trenzado.

Poliuretano trenzado para el artículo 1810

*Para tubo en Poliuretano se aconseja una dureza de 98 shore.

Plastic tubes:

PA6, PA11, PA12, Polyethylene, *Polyurethane, Braided PVC.

Braided polyurethane for Art.1820

*For Polyurethane hoses it is required a minimum hardness of 98 shore.

Fluidos compatibles / Fluids

Aire comprimido, fluidos o líquidos a baja presión compatibles con el tipo de conexión.

Compressed air, fluids and liquids at low pressure compatible with the connection.

1810

RACORDAJE PARA TUBERÍA EN GOMA - FITTING FOR RUBBER HOSE

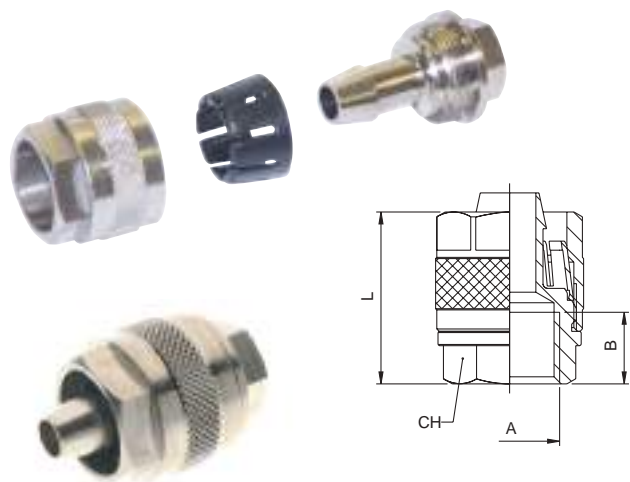

Código Code	Tubo Tube	A	B	L	CH	Conf. Pack.
018100003	14/6	1/4	11	30	16	25
018100005	17/8	1/4	11	31	16	25
018100006	19/10	1/4	11	31	17	25
018100007	23/13	1/2	17	36	24	25

RACORDAJE PARA TUBO EN POLIURETANO TRENZADO FITTINGS FOR BRAIDED POLYURETHANE HOSES



Código Code	Tubo Tube	A	B	L	CH	Conf. Pack.
018100001	10/6	1/4	11	30	15	25
018100002	12/8	1/4	11	31	16	25
018100004	15/10	1/4	11	31	17	25

1830

MACHO A BAYONETA - MALE BAYONET

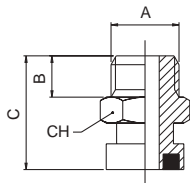

Código Code	A	B	C	CH	Conf. Pack.
018300001	1/8	6	19,5	15	25
018300002	1/4	8	22	15	25
018300003	3/8	9	23	19	25

1831

HEMBRA A BAYONETA - FEMALE BAYONET

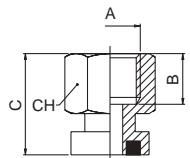

Código Code	A	B	C	CH	Conf. Pack.
018310001	1/8	8.5	19.5	15	25
018310002	1/4	11	22	17	25
018310003	3/8	11	22	20	25

1832

ESPIGA A BAYONETA - BAYONET WITH REST

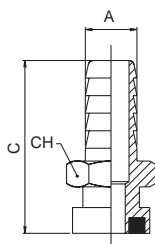

Código Code	Tubo Tube	A	C	CH	Conf. Pack.
018320001	int. 6	6	33.5	15	25
018320002	int. 7	7	33.5	15	25
018320003	int. 8	8	33.5	15	25
018320004	int. 9	9	33.5	15	25
018320005	int. 10	10	33.5	15	25
018320006	int. 12	12	33.5	15	25

1833

BAYONETA PORTAGOMA - BAYONET FOR RUBBER HOSE

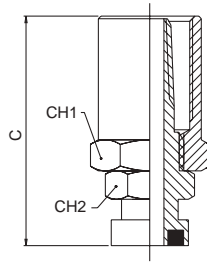

Código Code	Tubo Tube	CH1	CH2	C	Conf. Pack.
0183300001	est. 14 - int. 6	17	15	44,5	25
0183300002	est. 17 - int. 8	20	15	44,5	25
0183300003	est. 19 - int. 10	22	15	44,5	25

1840

MACHO PORTAGOMA - MALE FOR RUBBER HOSE

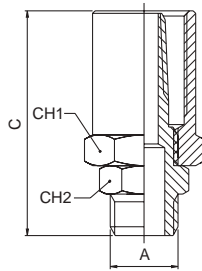

Código Code	Tubo Tube	A	CH1	CH2	C	Conf. Pack.
0184000008	10/6	1/4	15	17	43	25
0184000009	12/8	1/4	15	17	43	25
0184000001	14/6	1/4	17	17	43	25
0184000010	15/10	1/4	18	17	43	25
0184000002	17/8	1/4	20	17	43	25
0184000003	17/8	3/8	20	19	44	25
0184000004	19/10	1/4	22	17	43	25
0184000005	19/10	3/8	22	19	44	25

1841

HEMBRA PORTAGOMA - FEMALE FOR RUBBER HOSE

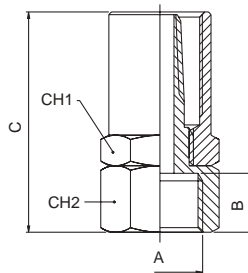

Código Code	Tubo Tube	A	B	C	CH1	CH2	Conf. Pack.
0184100006	10/6	1/4	11	43	15	17	25
0184100007	12/8	1/4	11	43	15	17	25
0184100001	14/6	1/4	11	43	17	17	25
0184100008	15/10	1/4	11	43	18	17	25
0184100002	17/8	1/4	11	43	20	17	25
0184100003	17/8	3/8	11,5	43,5	20	20	25
0184100004	19/10	1/4	11	43	22	17	25
0184100005	19/10	3/8	11,5	43,5	22	20	25

1850

MACHO CON TUERCA - MALE WITH MILLED NUT

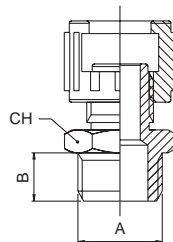

Código Code	A	B	CH	Conf. Pack.
0185000001	1/8	6	14	25
0185000002	1/4	8	15	25
0185000003	3/8	9	19	25

1851

HEMBRA CON TUERCA - FEMALE WITH MILLED NUT

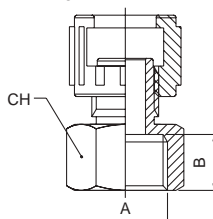

Código Code	A	B	CH	Conf. Pack.
0185100001	1/4	11	17	25
0185100002	3/8	11	20	25

1852

UNIÓN CON TUERCA - DOUBLE MILLED NUT

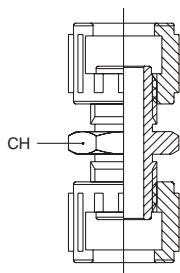

Código Code	A	CH	Conf. Pack.
0185200001	1/4	15	25

1853

T CON TUERCA - TEE WITH MILLED NUTS

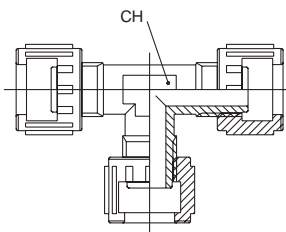

Código Code	A	CH	Conf. Pack.
0185300001	1/4	13	25

1855

RACOR RECTO A BAYONETA + TUERCA CON MUELLE
STRAIGHT FITTING WITH BAYONET CONNECTION + NUT AND SPRING

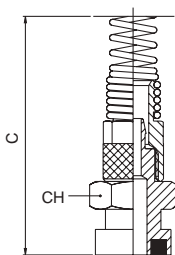

Código Code	Tubo Tube	CH	C	Conf. Pack.
0185500001	6/4	15	110	25
0185500002	8/6	15	115	25
0185500003	10/8	15	123	25
0185500004	12/10	16	130	25

1860

RACOR RECTO GIRATORIO A BAYONETA + TUERCA CON MUELLE
SWIVEL STRAIGHT FITTING WITH BAYONET CONNECTION + NUT AND SPRING

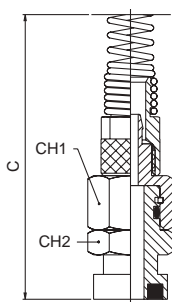

Código Code	Tubo Tube	CH1	CH2	C	Conf. Pack.
0186000001	6/4	15	15	120	25
0186000002	8/6	15	15	125	25
0186000003	10/8	15	15	134	25
0186000004	12/10	17	17	141	25

1808

TUERCA - MILLED NUT

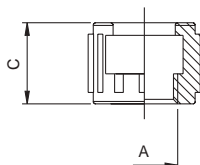

Código Code	A	C	Conf. Pack.
01808008003NT	1/4	16	25

1864

JUNTA PARA RACORES A BAYONETA - TIGHTENING SEAL FOR FITTINGS WITH BAYONET CONNECTION

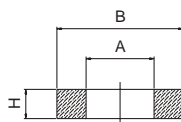

Código Code	A	B	H	Conf. Pack.
018640024Z700	7	13	3	50

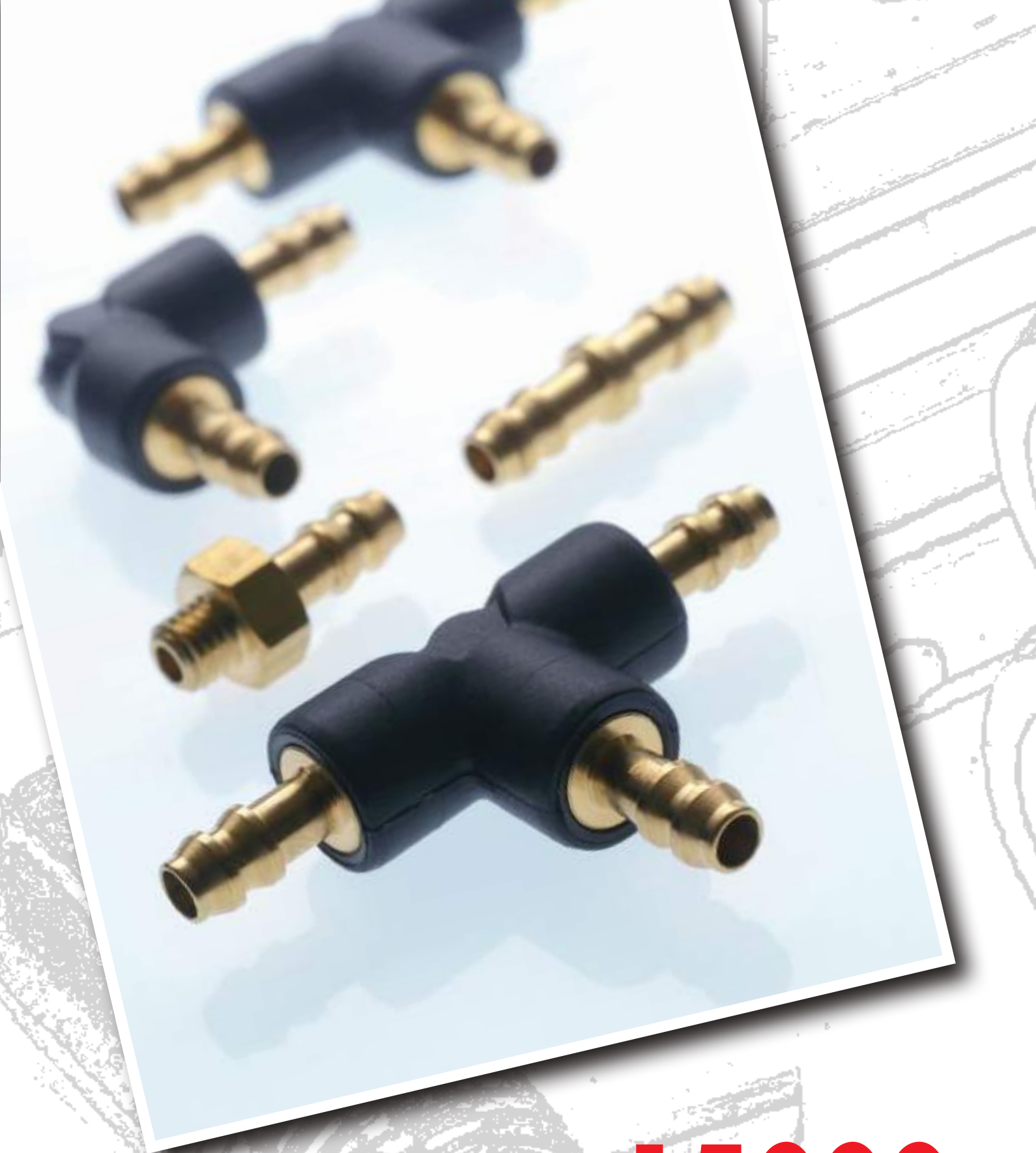

Serie 15000

RACORDAJE PORTAGOMA PARA TUBO EN MATERIAL PLÁSTICO
HOSE ADAPTERS FOR PLASTIC TUBES

Características técnicas / Technical Characteristics

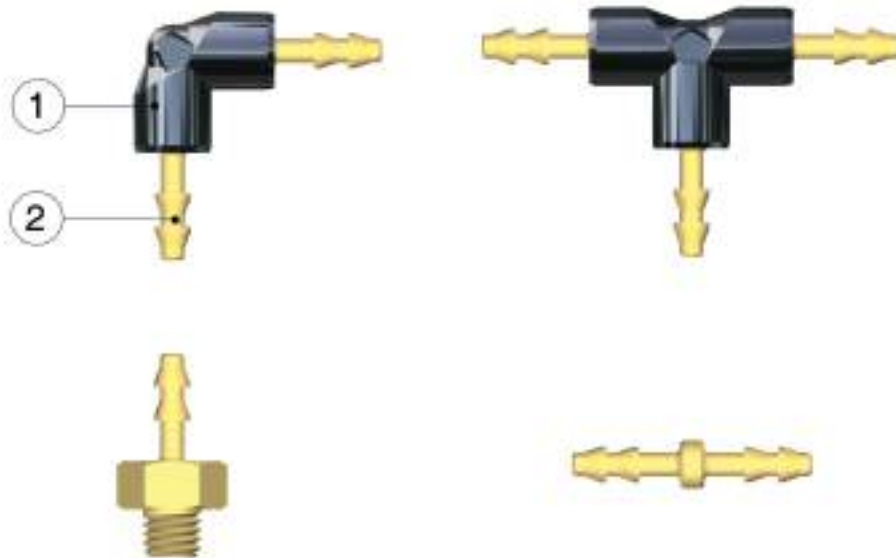

Materiales y componentes / Specifications

- 1 Cuerpo en tecnopolímero
- 2 Portagoma en latón

- 1 Tecnopolymer Body
- 2 Brass Hose Adapter

Presiones / Pressures

Presión mínima / Minimum pressure: **-0.99 bar (-0.099 MPa)**
 Presión máxima / Maximum pressure: **10 bar (1 MPa)**

Temperaturas / Temperatures

Temperatura mínima / Minimum temperature: **-10 °C**
 Temperatura máxima / Maximum temperature: **+80 °C**

Roscas / Threads

Métrica conforme ISO R/262 / Metric in conformity with ISO R/262.

Tubos de conexión / Connection Tubes

Tubos en material plástico lineales:
Poliamida, Polietileno, Poliuretano.
 Flexible tubes in plastic:
 Polyamide, Polyethylene, Polyurethane.

Fluidos compatibles / Fluids

Aire comprimido / Compressed air.

15000

RACOR PORTAGOMA RECTO MACHO - STRAIGHT HOSE MALE ADAPTOR

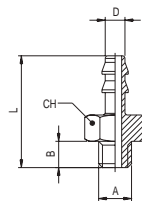

Código Code	D	A	B	L	CH	Conf. Pack.
150000014V00	2	M5	4	17	8	50
150000016Q00	3	M5	4	17	8	50
150000010R00	4	M5	4	18	8	50
150000017S00	6	M5	4	18	8	50

15040

RACOR PORTAGOMA RECTO INTERMEDIO - STRAIGHT BULKHEAD HOSE ADAPTOR

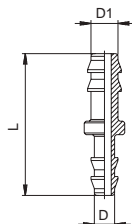

Código Code	D	D1	L	Conf. Pack.
15040001W900	2	2	20	50
15040001FG00	3	2	20	50
15040001X000	3	3	20	50
15040001FH00	4	3	21	50
15040001X100	4	4	22	50
15040001FM00	6	4	22	50
15040001X400	6	6	22	50

15130

RACOR PORTAGOMA A L INTERMEDIO - BULKHEAD ELBOW HOSE ADAPTOR

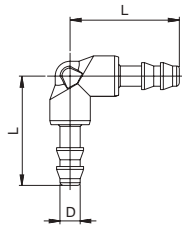

Código Code	D	L	Conf. Pack.
151300001	2	17.5	50
151300002	3	17.5	50
151300003	4	22	50
151300004	6	22	50

15230

RACOR PORTAGOMA A T INTERMEDIO - BULKHEAD TEE HOSE ADAPTOR

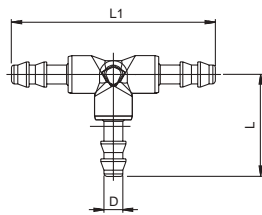

Código Code	D	L	L1	Conf. Pack.
152300001	2	17.5	35	50
152300002	3	17.5	35	50
152300003	4	22	44	50
152300004	6	22	44	50



TUBES

Serie Tubes

TUBOS EN MATERIAL PLÁSTICO
PLASTIC TUBES

Características Técnicas / Technical Characteristics
Materiales / Materials

 POLIAMIDA
 POLYAMIDE

 POLIURETANO 98 SHORE A
 POLYURETHANE 98 SHORE A

PTFE

Colores Standard / Standard Colors

- NT (TRANSPARENTE/NEUTRAL)
- AZ (AZUL/LIGHT BLUE)
- BL (AZUL OSCURO/BLUE)
- NE (NEGRO/BLACK)

Tubo en Poliamida
Polyamide Tube

TB12

TUBO EN POLIAMIDA - POLYAMIDE TUBE

Temperatura de ejercicio / Temperature Range
De -40°C a +100°C
From -40°C to +100°C

 A continuación mostramos una tabla de las presiones expresadas en % en función de la temperatura.
Below is a table of pressure values expressed in% as a function of temperature.

20°	40°	60°	80°	100°
100%	85%	60%	40%	35%

Código Code	Código Code	Código Code	Ext. mm	Int. mm	Radio Curvatura Bending Radius	Presión de ejercicio Working pressure (a/at 23°C)	Presión de rotura Burst pressure (a/at 23°C)	Conf. Pack.
TB1200427NT	TB1200427AZ	TB1200427NE	4	2.7	25mm	32 bar	97 bar	100 Mt
TB1200530NT	TB1200530AZ	TB1200530NE	5	3	30mm	33 bar	100 bar	100 Mt
TB1200640NT	TB1200640AZ	TB1200640NE	6	4	35mm	33 bar	100 bar	100 Mt
TB1200860NT	TB1200860AZ	TB1200860NE	8	6	40mm	24 bar	71 bar	100 Mt
TB1201080NT	TB1201080AZ	TB1201080NE	10	8	60mm	19 bar	56 bar	100 Mt
TB1212100NT	TB1212100AZ	TB1212100NE	12	10	85mm	15 bar	45 bar	100 Mt
TB1214120NT	TB1214120AZ	TB1214120NE	14	12	85mm	10 bar	31 bar	50 Mt
TB1215125NT	TB1215125AZ	TB1215125NE	15	12.5	100mm	12 bar	36 bar	50 Mt

TS12

TUBO EN POLIAMIDA EN CAJA - LONGITUD 25 Mt. - POLYAMIDE TUBE IN BOX - LENGHT 25 Mt.

Temperatura de ejercicio / Temperature Range
De -40°C a +100°C
From -40°C to +100°C

 A continuación mostramos una tabla de las presiones expresadas en % en función de la temperatura.
Below is a table of pressure values expressed in% depending on of temperature.

20°	40°	60°	80°	100°
100%	85%	60%	40%	35%

Código Code	Código Code	Código Code	Ext. mm	Int. mm	Radio Curvatura Bending Radius	Presión de ejercicio Working pressure (a/at 23°C)	Presión de rotura Burst pressure (a/at 23°C)	Conf. Pack.
TS1200427NT	TS1200427AZ	TS1200427NE	4	2.7	25mm	32 bar	97 bar	1
TS1200640NT	TS1200640AZ	TS1200640NE	6	4	35mm	33 bar	100 bar	1
TS1200860NT	TS1200860AZ	TS1200860NE	8	6	40mm	24 bar	71 bar	1
TS1201080NT	TS1201080AZ	TS1201080NE	10	8	60mm	19 bar	56 bar	1
TS1212100NT	TS1212100AZ	TS1212100NE	12	10	85mm	15 bar	45 bar	1

Tubo en Poliuretano 98 Shore A / Polyurethane 98 Shore A Tube

TBPU

TUBO EN POLIURETANO 98 SHORE A - 98 SHORE A POLYURETHANE TUBE



Temperatura de ejercicio / Temperature Range

De -40°C a +60°C

From -40°C to +60°C

Código Code	Código Code	Código Code	Ext. mm	Int. mm	Radio Curvatura Bending Radius	Presión de ejercicio Working pressure (a/at 23°C)	Presión de rotura Burst pressure (a/at 23°C)	Conf. Pack.
TBPU00425NT	TBPU00425AZ	TBPU00425NE	4	2.5	15 mm	10 bar	40 bar	100 Mt
TBPU00530NT	TBPU00530AZ	TBPU00530NE	5	3	16 mm	12 bar	50 bar	100 Mt
TBPU00640NT	TBPU00640AZ	TBPU00640NE	6	4	28 mm	10 bar	40 bar	100 Mt
TBPU00855NT	TBPU00855AZ	TBPU00855NE	8	5.5	30 mm	10 bar	40 bar	100 Mt
TBPU00860NT	TBPU00860AZ	TBPU00860NE	8	6	35 mm	8 bar	32 bar	100 Mt
TBPU01080NT	TBPU01080AZ	TBPU01080NE	10	8	45 mm	5.5 bar	22 bar	100 Mt
TBPU01290NT	TBPU01290AZ	TBPU01290NE	12	9	50 mm	6 bar	25 bar	100 Mt

TSPU

TUBO EN POLIURETANO 98 SHORE EN CAJA - LONGITUD 25 Mt. - 98 SHORE POLYURETHANE TUBE IN BOX - LENGHT 25 Mt.



Temperatura de ejercicio / Temperature Range

De -40°C a +60°C

From -40°C to +60°C

Código Code	Código Code	Código Code	Ext. mm	Int. mm	Radio Curvatura Bending Radius	Presión de ejercicio Working pressure (a/at 23°C)	Presión de rotura Burst pressure (a/at 23°C)	Conf. Pack.
TSPU00425NT	TSPU00425AZ	TSPU00425NE	4	2.5	15 mm	10 bar	40 bar	1
TSPU00640NT	TSPU00640AZ	TSPU00640NE	6	4	18 mm	10 bar	40 bar	1
TSPU00855NT	TSPU00855AZ	TSPU00855NE	8	5.5	30 mm	10 bar	40 bar	1
TSPU00860NT	TSPU00860AZ	TSPU00860NE	8	6	35 mm	8 bar	32 bar	1
TSPU01080NT	TSPU01080AZ	TSPU01080NE	10	8	45 mm	8 bar	24 bar	1
TSPU01290NT	TSPU01290AZ	TSPU01290NE	12	9	50 mm	10 bar	25 bar	1

Espirales en Poliamida sin terminales

Spirals polyamide without tangs

SS12

ESPIRAL EN POLIAMIDA SIN TERMINALES - POLYAMIDE SPIRAL WITHOUT TANGS



Colores standard / Standard Color

BL (AZUL

OSCURO)/BLUE)

Temperatura de ejercicio / Temperature Range

Range

De -40°C a +70°C / From -40°C to +70°C

Código Code	Ext. mm	Int. mm	Longitud Lineal Mt. Linear Length Mt.	Longitud en reposo mm. Stowed Length mm.	Longitud de Ejercicio Mt. Working Length Mt.	Presión de ejercicio Working pressure (a/at 23°C)	Presión de rotura Burst pressure (a/at 23°C)	Conf. Pack.
SS120064030BL	6	4	30	870 mm	17 Mt.	27 bar	81 bar	1
SS120086030BL	8	6	30	910 mm	17 Mt.	20 bar	60 bar	1
SS120108030BL	10	8	30	990 mm	17 Mt.	15 bar	45 bar	1
SS120121030BL	12	10	30	870 mm	17 Mt.	13 bar	39 bar	1

Espirales en Poliuretano 98 shore A con terminales / Spirals Polyurethane 98 shore A with tangs

SDPU

ESPIRAL EN POLIURETANO 98 SHORE A CON TERMINALES - SPIRAL POLYURETHANE 98 SHORE A WITH TANGS

Colores standard / Standard Color
AZ (AZUL/LIGHT BLUE)
Temperatura de ejercicio / Temperature Range
De -40°C a +60°C / From -40°C to +60°C
Terminales - Terminals
Medida - Size
Terminal SX/DX - Terminals Left/Right

6 - 4	100 - 100
8 - 5.5	120 - 500
10 - 6.5	120 - 500
12 - 8	120 - 500

Código Code	Ext. mm	Int. mm	Longitud Lineal Mt. Linear Length Mt.	Longitud en reposo mm. Stowed Length mm.	Longitud de Ejercicio Mt. Working Length Mt.	Presión de ejercicio Working pressure (a/at 23°C)	Presión de rotura Burst pressure (a/at 23°C)	Conf. Pack.
SDPU0064004AZ	6	4	4	325 mm	3Mt.	15 bar	32 bar	1
SDPU0085505AZ	8	5.5	5	410 mm	4Mt.	10 bar	30 bar	1
SDPU0106505AZ	10	6.5	5	330 mm	4Mt.	14 bar	34 bar	1
SDPU0120805AZ	12	8	5	305 mm	3Mt.	15 bar	32 bar	1

SDPU

ESPIRAL EN POLIURETANO 98 SHORE A CON TERMINALES - SPIRAL POLYURETHANE 98 SHORE A WITH TANGS

Colores standard / Standard Color
AZ (AZUL/LIGHT BLUE)
Temperatura de ejercicio / Temperature Range
De -40°C a +60°C / From -40°C to +60°C
Terminales - Terminals
Medida - Size
Terminal SX/DX - Terminals Left/Right

8 - 5.5	120 - 500
10 - 6.5	120 - 500
12 - 8	120 - 500

Código Code	Ext. mm	Int. mm	Longitud Lineal Mt. Linear Length Mt.	Longitud en reposo mm. Stowed Length mm.	Longitud de Ejercicio Mt. Working Length Mt.	Presión de ejercicio Working pressure (a/at 23°C)	Presión de rotura Burst pressure (a/at 23°C)	Conf. Pack.
SDPU0085075AZ	8	5.5	7.5	660 mm	6Mt.	10 bar	30 bar	1
SDPU0106575AZ	10	6.5	7.5	500 mm	6Mt.	14 bar	34 bar	1
SDPU0120875AZ	12	8	7.5	430 mm	6Mt.	15 bar	32 bar	1

Tubo Especial / Special Tube

TBPF

TUBO FLEXIBLE EN PTFE - PTFE FLEXIBLE TUBE

Aplicaciones industriales / Industrial Applications

- Transporte de Fluidos / Transport Fluids**
- Alimentaria Alimentos & Bebidas / Food Food & Beverage**
- Electrodomésticos / Appliances**
- Electrónico / Electronic**
- Automovilístico y motociclístico / Automotive and motorcycle**
- Equipos médicos y laboratorios / Medical equipment and laboratory**
- Semiconductores / Semiconductors**
- Distribución artículos técnicos / Distribution technical articles**

Temperatura de ejercicio / Temperature Range
De -60°C a +260°C
From -60°C to +260°C

Código Code	Ext. mm	Int. mm	Radio Curvatura Bending Radius	Presión de ejercicio Working pressure (a/at 23°C)	Presión de rotura Burst pressure (a/at 23°C)	Conf. Pack.
TBPF00420NT	4	2	16 mm	35 Bar	110 Bar	50 Mt
TBPF00427NT	4	2.7	18 mm	23 Bar	70 Bar	50 Mt
TBPF00530NT	5	3	25 mm	28 Bar	85 Bar	50 Mt
TBPF00640NT	6	4	36 mm	23 Bar	70 Bar	50 Mt
TBPF00860NT	8	6	64 mm	15 Bar	50 Bar	50 Mt
TBPF01080NT	10	8	100 mm	13 Bar	40 Bar	50 Mt
TBPF01210NT	12	10	144 mm	10 Bar	30 Bar	50 Mt



Serie **QUICK COUPLINGS**

ENCHUFES RÁPIDOS
AUTOMATIC QUICK COUPLINGS

Q

Características Técnicas / Technical Characteristics

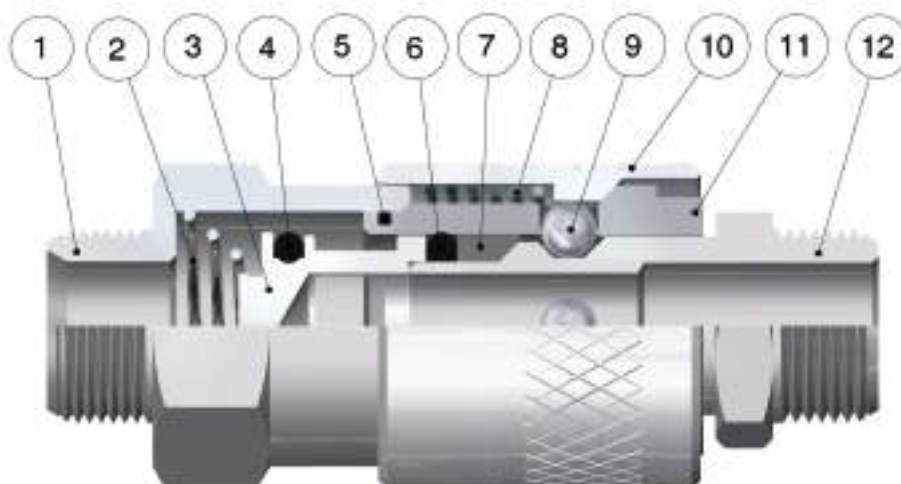

Materiales y Componentes / Component Parts and Materials

- 1 TERMINAL DE CONEXIÓN EN LATÓN NIQUELADO
- 2 MUELLE OBTURADOR EN ACERO AISI 302
- 3 OBTURADOR EN LATÓN NIQUELADO
- 4 JUNTA TÓRICA OBTURADOR EN NBR 70 (FKM A DEMANDA)
- 5 JUNTA TÓRICA CUERPO EN NBR 70 (FKM A DEMANDA)
- 6 JUNTA TÓRICA ENCHUFE EN NBR 70 (FKM A DEMANDA)
- 7 ANILLO GUÍA ENCHUFE EN LATÓN NIQUELADO
- 8 MUELLE TUERCA EN ACERO AISI 302
- 9 ESFERA EN ACERO AISI 420
- 10 TUERCA EN LATÓN NIQUELADO
- 11 CUERPO EN LATÓN NIQUELADO
- 12 ENCHUFE EN LATÓN NIQUELADO

- 1 NICKEL-PLATED BRASS COUPLING BACK PART
- 2 STAINLESS STEEL AISI 302 SHUTTER SPRING
- 3 NICKEL-PLATED BRASS SHUTTER
- 4 NBR 70 SHUTTER O-RING SEALS (IF REQUESTED FKM)
- 5 NBR 70 BODY O-RING SEALS (IF REQUESTED FKM)
- 6 NBR 70 PLUG O-RING SEALS (IF REQUESTED FKM)
- 7 NICKEL-PLATED BRASS GUIDE RING COUPLING
- 8 STAINLESS STEEL AISI 302 RING NUT SPRING
- 9 STAINLESS STEEL AISI 420 BALLS
- 10 NICKEL-PLATED BRASS SLEEVE
- 11 NICKEL-PLATED BRASS BODY
- 12 NICKEL-PLATED BRASS PLUG OUTLINE

Este tipo de juntas estan disponibles solo para le serie 110, 120, 160, 180, 190, 280.
This kind of sealing is available only for following series 110, 120, 160, 180, 190, 280.

FKM bajo demanda
FKM If required

Presiones / Pressures

Consultar la página inicial de cada serie.
See the first page of each series.

Temperaturas / Temperatures

Temperatura mínima / Minimum temperature: -18 °C
Temperatura máxima / Maximum temperature: +80 °C

NB: -10°C - +200°C CON JUNTA TÓRICA EN FKM
NB: -10°C - +200°C WITH FKM O-RING SEAL

Roscas / Threads

Gas cilíndrica conforme ISO 228 / Parallel gas in conformity with ISO 228.

Tubos de conexión / Connection Tubes

Tubos en material plástico, lineales o espiralados. Tubos en goma.

Flexible tubes in plastic and rubber.

Fluidos compatibles / Fluids

Aire comprimido / Compressed air.

La gama de los adaptadores para el acoplamiento con los varios tipos de enchufes comprende diferentes tipos de normativas entre las más comunes a nivel internacional. La siguiente tabla representa los varios modelos a escala 1:1 con las principales características y medidas para una correcta identificación y elección.

The couplings range for the connection with joints include various types of plugs which match the most common international couplings. The following table gives the various outline detail scale 1:1 with the main characteristics and sizes for correct selection.

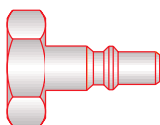
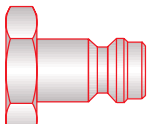
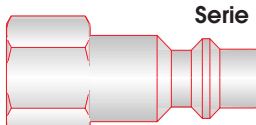
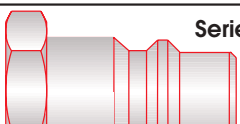
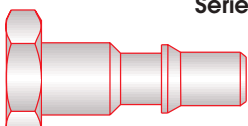
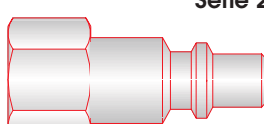
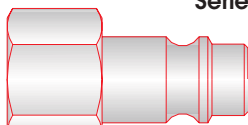
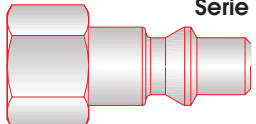
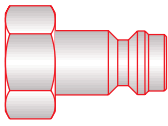
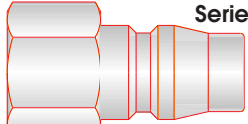
PERFIL ENCHUFE COUPLING PLUG OUTLINE Escala/Scale 1:1	DN	INTERCAMBIABILIDAD INTERCHANGEABILITY							
 Serie 200	2,5 mm	Norma UNI ISO 6150 A-6							
 Serie 210	5 mm	MIGNON	RECTUS 21 - 90 SERIES			LEGRIS 21		CAMOZZI 5150 SERIES	
 Serie 220	5,5 mm	Norma UNI ISO 6150 B-12	RECTUS 23-24 SERIES	PARKER 30-1/4 SERIES	CEJN 310	LEGRIS 23 - 24	IRM06		
 Serie 230	9 mm	Norma UNI ISO 6150 B-15	RECTUS 30 SERIES	PARKER 30-3/8 SERIES	CEJN 430	LEGRIS 30	IRM08		
 Serie 240	5,5 mm	Norma UNI ISO 6150 C-10	RECTUS 18 SERIES		CEJN 291 SERIES	LEGRIS 18		RBE6 SERIES	OETIKER ISO STANDARD DP 6150
 Serie 250	5 mm	PERFIL ITALIANO							
 Serie 260	7,5 mm	PERFIL EUROPEO	RECTUS 25 - 26		CEJN 320 SERIES	LEGRIS 25 - 26	ERC07	CAMOZZI 5180 SERIES	
 Serie 270	5,5 mm	PERFIL SUECO	RECTUS 14-22 SERIES	PARKER 50 SERIES	CEJN 300	LEGRIS 14 - 22	ARM06	ARO 210	ORION 44510 JWL 522 JWL 532
 Serie 280	5 mm	PERFIL MIGNON a doble obturación							
 Serie 500	7,5 mm	PERFIL JAPONÉS	RECTUS 13 SERIES		CEJN 315 SERIES	LEGRIS 13			NITTO KOHKI

CARACTERÍSTICAS DE FLUJO ENCHUFES RÁPIDOS SERIE 100-200

FLOW CHARACTERISTICS AUTOMATIC QUICK COUPLINGS 100-200 SERIES

CARACTERÍSTICAS DE FLUJO CON ESCAPE ATMÓSFERA

FLOW CHARACTERISTIC WITH EXHAUST TO ATMOSPHERE

Caudal de aire Q a 0°C y 1013 mbar (NI/min)
Air rate Q at 0°C and 1013 mbar (NI/min)

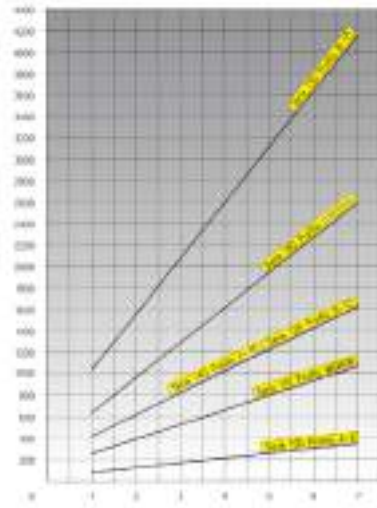

PRESIÓN DE ENTRADA P1 (bar)
INLET PRESSURE P1 (bar)

CARACTERÍSTICAS DE FLUJO CON PÉRDIDA DE CARGA DE 1 BAR

FLOW CHARACTERISTIC WITH PRESSURE DROP OF 1 BAR

Caudal de aire Q a 0°C y 1013 mbar (NI/min)
Air rate Q at 0°C and 1013 mbar (NI/min)

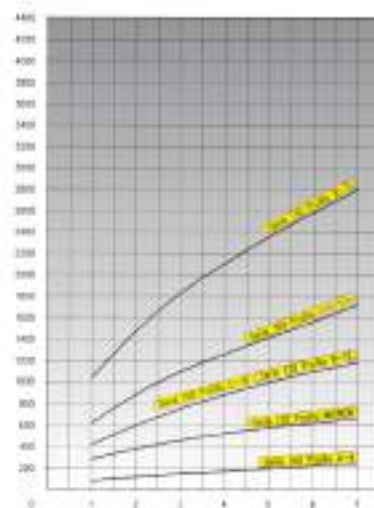

PRESIÓN DE ENTRADA P1 (bar)
INLET PRESSURE P1 (bar)

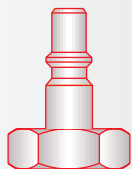

100-200 SERIES UNI ISO 6150 A-6

DN 2,5 mm

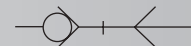

UNI ISO 6150
A-6
1:1

Presión de ejercicio / Working pressure: 0 - 10 bar

101

ENCHUFE MACHO - MALE SOCKET



Código Code	A	B	C	D	CH	Conf. Pack.
0010100001	1/8	6	32	13	11	10

102

ENCHUFE HEMBRA - FEMALE SOCKET



Código Code	A	B	C	D	CH	Conf. Pack.
0010200001	1/8	7.5	34	13	12	10

104

ENCHUFE TUBO - COMPRESSION SOCKET

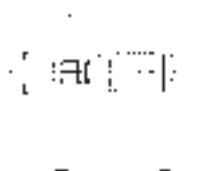

Código Code	A	B	C	D	CH	Conf. Pack.
0010400001	4/2.7	-	39	13	11	10
0010400002	6/4	-	40.5	13	11	10

105

ENCHUFE ESPIGA - SOCKET WITH REST FOR RUBBER HOSE

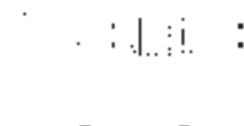

Código Code	A	B	C	D	CH	Conf. Pack.
0010500001	4	-	46.5	13	11	10
0010500002	6	-	46.5	13	11	10

201

ADAPTADOR MACHO - MALE PLUG

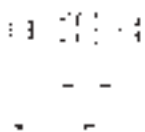

Código Code	A	B	C	D	CH	Conf. Pack.
00201000102NB	1/8	6	26.5	-	11	25

202

ADAPTADOR HEMBRA - FEMALE PLUG



Código Code	A	B	C	D	CH	Conf. Pack.
00202000102NB	1/8	7.5	25	-	12	25

204

ADAPTADOR TUBO - COMPRESSION PLUG

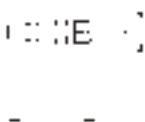

Código Code	A	B	C	D	CH	Conf. Pack.
0020400001	4/2.7	-	32.5	-	11	25
0020400002	6/4	-	34	-	11	25

205

ADAPTADOR ESPIGA - PLUG WITH REST FOR RUBBER HOSE

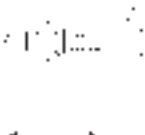

Código Code	A	B	C	D	CH	Conf. Pack.
002050001X1NB	4	-	38.5	11	-	25
002050001X4NB	6	-	38.5	11	-	25

110-210 SERIES MIGNON

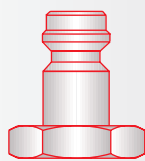

MIGNON
1:1

DN 5 mm

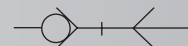

Presión de ejercicio / Working pressure: 0 - 12 bar

111

ENCHUFE MACHO - MALE SOCKET



Código Code	A	B	C	D	CH	Conf. Pack.
0011100001	1/8	6	35.5	18	16	10
0011100002	1/4	8	37.5	18	16	10
0011100003	3/8	9	38.5	18	19	10

112

ENCHUFE HEMBRA - FEMALE SOCKET

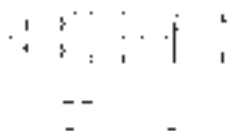

Código Code	A	B	C	D	CH	Conf. Pack.
0011200001	1/8	7.5	35	18	16	10
0011200002	1/4	11	38.5	18	16	10
0011200003	3/8	11.5	39	18	19	10

113

ENCHUFE TUBO CON MUELLE - COMPRESSION SOCKET WITH SPRING

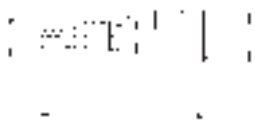

Código Code	A	B	C	D	CH	Conf. Pack.
0011300001	6/4	-	124	18	16	10
0011300002	8/6	-	129.5	18	16	10

114

ENCHUFE TUBO - COMPRESSION SOCKET

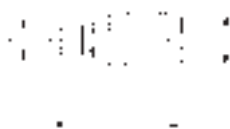

Código Code	A	B	C	D	CH	Conf. Pack.
0011400001	6/4	-	42	18	16	10
0011400002	8/6	-	42	18	16	10

115

ENCHUFE ESPIGA - SOCKET WITH REST FOR RUBBER HOSE



Código Code	A	B	C	D	CH	Conf. Pack.
0011500001	4	-	48	18	16	10
0011500002	6	-	48	18	16	10
0011500003	8	-	48	18	16	10

116

ENCHUFE PASATABIQUES MACHO - BULKHEAD SOCKET WITH MALE THREADED CONNECTION



Código Code	A	B _{max}	C	D	CH1	CH2	Conf. Pack.
001160001	1/8	6	47.5	18	14	16	10
001160002	1/4	8	49.5	18	17	16	10
001160003	3/8	9	51.5	18	20	19	10

117

ENCHUFE PASATABIQUES TUBO CON MUELLE - BULKHEAD SOCKET WITH COMPRESSION CONNECTION WITH SPRING

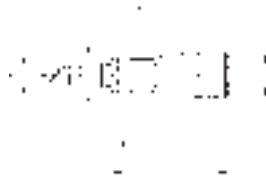

Código Code	A	B _{max}	C	D	F	CH1	CH2	Conf. Pack.
001170001	6/4	8	55.5	18	M10x1	14	16	10
001170002	8/6	8	55.5	18	M12x1	17	16	10

118

ENCHUFE PASATABIQUES TUBO - BULKHEAD SOCKET WITH COMPRESSION CONNECTION



Código Code	A	B _{max}	C	D	F	CH1	CH2	Conf. Pack.
001180001	6/4	8	55.5	18	M10x1	14	16	10
001180002	8/6	8	55.5	18	M12x1	17	16	10

119

ENCHUFE PASATABIQUES ESPIGA - BULKHEAD SOCKET WITH SPIGOT FOR RUBBER HOSE



Código Code	A	B _{max}	C	D	F	CH1	CH2	Conf. Pack.
001190001	4	8	61	18	M10x1	14	16	10
001190002	6	8	61	18	M12x1	17	16	10
001190003	8	8	62	18	M14x1	17	16	10

111SW

ENCHUFE SIN OBTURADOR MACHO - MALE SOCKET WITHOUT SHUTTER



Código Code	A	B	C	D	CH	Conf. Pack.
00111SW001	1/8	6	35.5	18	16	10
00111SW002	1/4	8	37.5	18	16	10

112SW

ENCHUFE SIN OBTURADOR HEMBRA - FEMALE SOCKET WITHOUT SHUTTER

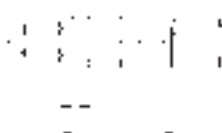

Código Code	A	B	C	D	CH	Conf. Pack.
00112SW001	1/8	7.5	35	18	16	10
00112SW002	1/4	11	38.5	18	16	10

211

ADAPTADOR MACHO - MALE PLUG

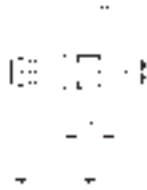

Código Code	A	B	C	D	CH	Conf. Pack.
00211000102NB	1/8	6	26	-	14	25
00211000103NB	1/4	8	28.5	-	17	25
00211000104NB	3/8	9	29.5	-	19	25

212

ADAPTADOR HEMBRA - FEMALE PLUG

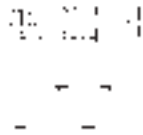

Código Code	A	B	C	D	CH	Conf. Pack.
00212000102NB	1/8	7.5	25	-	14	25
00212000103NB	1/4	11	28.5	-	17	25
00212000104NB	3/8	11.5	29	-	19	25

213

ADAPTADOR TUBO CON MUELLE - COMPRESSION PLUG WITH SPRING

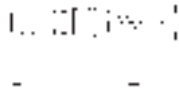

Código Code	A	B	C	D	CH	Conf. Pack.
0021300001	6/4	-	115	-	12	25
0021300002	8/6	-	118.5	-	12	25

214

ADAPTADOR TUBO - COMPRESSION PLUG



Código Code	A	B	C	D	CH	Conf. Pack.
0021400001	6/4	-	33	-	12	25
0021400002	8/6	-	33	-	12	25

215

ADAPTADOR ESPIGA - PLUG WITH REST FOR RUBBER HOSE

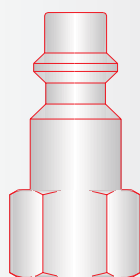

Código Code	A	B	C	D	CH	Conf. Pack.
002150001X1NB	4	-	35	9	-	25
002150001X4NB	6	-	35	9	-	25
002150001X7NB	8	-	38	12	-	25

B-12
1:1

120-220 SERIES

UNI ISO 6150 B-12

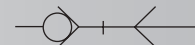
 **5,5 mm**

Presión de ejercicio / Working pressure: 0 - 16 bar

121

ENCHUFE MACHO - MALE SOCKET

Código Code	A	B	C	D	CH	Conf. Pack.
0012100001	1/4	8	53	24	21	10
0012100002	3/8	9	54	24	21	10
0012100003	1/2	10	55	24	24	10

122

ENCHUFE HEMBRA - FEMALE SOCKET



Código Code	A	B	C	D	CH	Conf. Pack.
0012200001	1/4	11	55	24	21	10
0012200002	3/8	11.5	55.5	24	21	10
0012200003	1/2	14	59	24	24	10

123

ENCHUFE TUBO CON MUELLE - COMPRESSION SOCKET WITH SPRING

Código Code	A	B	C	D	CH	Conf. Pack.
0012300001	6/4	-	141	24	21	10
0012300002	8/6	-	146.5	24	21	10
0012300003	10/8	-	154	24	21	10

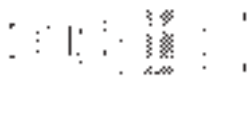
124

ENCHUFE TUBO - COMPRESSION SOCKET

Código Code	A	B	C	D	CH	Conf. Pack.
0012400001	6/4	-	59	24	21	10
0012400002	8/6	-	59	24	21	10
0012400003	10/8	-	60	24	21	10

125

ENCHUFE ESPIGA - SOCKET WITH REST FOR RUBBER HOSE

Código Code	A	B	C	D	CH	Conf. Pack.
0012500001	6	-	64	24	21	10
0012500002	8	-	64	24	21	10
0012500003	10	-	64	24	21	10
0012500004	12	-	64	24	21	10

126

ENCHUFE CON PORTAGOMA - SOCKET FOR RUBBER HOSE



Código Code	A	B	C	D	CH	Conf. Pack.
001260001	14/6	-	72	24	21	10
001260002	17/8	-	72	24	21	10
001260003	19/10	-	72	24	21	10

221

ADAPTADOR MACHO - MALE PLUG



Código Code	A	B	C	D	CH	Conf. Pack.
00221000103NB	1/4	8	36.5	-	17	25
00221000104NB	3/8	9	37.5	-	19	25
00221000105NB	1/2	10	39	-	24	25

221AC

ADAPTADOR EN AVP MACHO - AVP MALE PLUG



**ACERO
STEEL**

Código Code	A	B	C	D	CH	Conf. Pack.
221AC005103ZI	1/4	8	36.5	-	17	25
221AC005104ZI	3/8	9	37.5	-	19	25
221AC005105ZI	1/2	10	39	-	24	25

222

ADAPTADOR HEMBRA - FEMALE PLUG



Código Code	A	B	C	D	CH	Conf. Pack.
00222000103NB	1/4	11	36.5	-	17	25
00222000104NB	3/8	11.5	37	-	19	25
00222000105NB	1/2	14	39.5	-	24	25

222AC

ADAPTADOR EN AVP HEMBRA - AVP FEMALE PLUG



**ACERO
STEEL**

Código Code	A	B	C	D	CH	Conf. Pack.
222AC005103ZI	1/4	11	36.5	-	17	25
222AC005104ZI	3/8	11.5	37	-	19	25
222AC005105ZI	1/2	14	39.5	-	24	25

223

ADAPTADOR TUBO CON MUELLE - COMPRESSION PLUG WITH SPRING



Código Code	A	B	C	D	CH	Conf. Pack.
0022300001	6/4	-	123	-	13	25
0022300002	8/6	-	128.5	-	13	25
0022300003	10/8	-	136	-	14	25
0022300004	12/10	-	142	-	16	25

224

ADAPTADOR TUBO - COMPRESSION PLUG

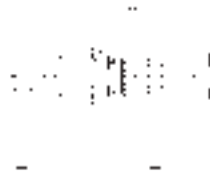

Código Code	A	B	C	D	CH	Conf. Pack.
0022400001	6/4	-	41	-	13	25
0022400002	8/6	-	41	-	13	25
0022400003	10/8	-	43	-	14	25
0022400004	12/10	-	45	-	16	25

225

ADAPTADOR ESPIGA - PLUG WITH REST FOR RUBBER HOSE



Código Code	A	B	C	D	CH	Conf. Pack.
00225000X4NB	6	-	43.5	12	-	25
00225000X7NB	8	-	43.5	12	-	25
00225000X9NB	10	-	46	14	-	25
00225000Y1NB	12	-	46	16	-	25

225AC

ADAPTADOR EN AVP ESPIGA - AVP PLUG WITH REST FOR RUBBER HOSE

**ACERO
STEEL**



Código Code	A	B	C	D	CH	Conf. Pack.
225AC0051X4ZI	6	-	43.5	12	-	25
225AC0051X7ZI	8	-	43.5	12	-	25
225AC0051X9ZI	10	-	46	14	-	25
225AC0051Y1ZI	12	-	46	16	-	25

227

ADAPTADOR BAYONETA - BAYONET PLUG



Código Code	A	B	C	D	CH	Conf. Pack.
0022700001	15	-	37	-	15	25

228

ADAPTADOR DE DESCARGA PROGRESIVA - PLUG WITH GRADUAL EXHAUST

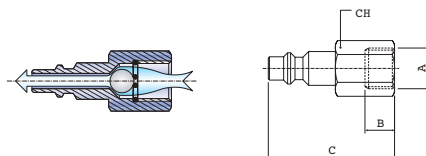

Código Code	A	B	C	CH	Conf. Pack.
0022800001	1/4	11	45	17	10

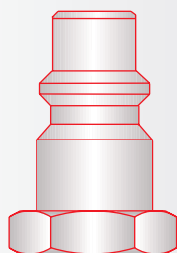

UNI ISO 6150
B-15
1:1

130-230 SERIES UNI ISO 6150 B-15

DN 9 mm

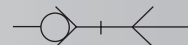

Presión de ejercicio / Working pressure: 0 - 16 bar

131

ENCHUFE MACHO - MALE SOCKET



Código Code	A	B	C	D	CH	Conf. Pack.
001310001	3/8	9	56	28	24	10
001310002	1/2	10	56	28	24	10

132

ENCHUFE HEMBRA - FEMALE SOCKET



Código Code	A	B	C	D	CH	Conf. Pack.
001320001	3/8	11.5	56.5	28	24	10
001320002	1/2	14	59	28	24	10

133

ENCHUFE TUBO CON MUELLE - COMPRESSION SOCKET WITH SPRING

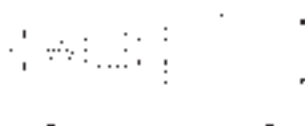

Código Code	A	B	C	D	CH	Conf. Pack.
001330001	10/8	-	155	28	24	10
001330002	12/10	-	162.5	28	24	10

134

ENCHUFE TUBO - COMPRESSION SOCKET

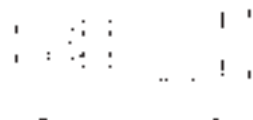

Código Code	A	B	C	D	CH	Conf. Pack.
001340001	10/8	-	61	28	24	10
001340002	12/10	-	63	28	24	10

135

ENCHUFE ESPIGA - SOCKET WITH REST FOR RUBBER HOSE

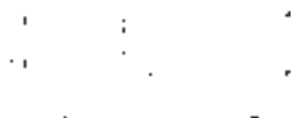

Código Code	A	B	C	D	CH	Conf. Pack.
001350001	8	-	66	28	24	10
001350002	10	-	66	28	24	10
001350003	12	-	66	28	24	10

231

ADAPTADOR MACHO - MALE PLUG



Código Code	A	B	C	D	CH	Conf. Pack.
00231000104NB	3/8	9	40	-	19	25
00231000105NB	1/2	10	41.5	-	24	25

232

ADAPTADOR HEMBRA - FEMALE PLUG



Código Code	A	B	C	D	CH	Conf. Pack.
00232000104NB	3/8	11.5	39.5	-	20	25
00232000105NB	1/2	14	42	-	24	25

233

ADAPTADOR TUBO CON MUELLE - COMPRESSION PLUG WITH SPRING

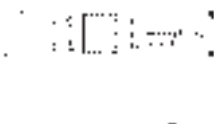

Código Code	A	B	C	D	CH	Conf. Pack.
0023300001	10/8	-	140	-	16	10
0023300002	12/10	-	147	-	16	10

234

ADAPTADOR TUBO - COMPRESSION PLUG



Código Code	A	B	C	D	CH	Conf. Pack.
0023400001	10/8	-	46	-	16	25
0023400002	12/10	-	47.5	-	16	10

235

ADAPTADOR ESPIGA - PLUG WITH REST FOR RUBBER HOSE



Código Code	A	B	C	D	CH	Conf. Pack.
002350001X7NB	8	-	46	-	-	25
002350001X9NB	10	-	46	-	-	25
002350001Y1NB	12	-	48.5	-	-	25

237

ADAPTADOR BAYONETA - BAYONET PLUG

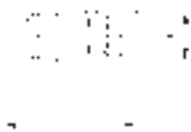

Código Code	A	B	C	D	CH	Conf. Pack.
0023700001	15	-	39.5	-	16	25

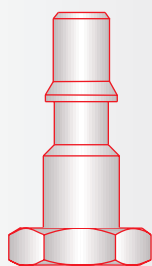
**UNI ISO 6150
C-10
1:1**

140-240 SERIES UNI ISO 6150 C-10

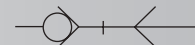
 **5,5 mm**

Presión de ejercicio / Working pressure: 0 - 25 bar

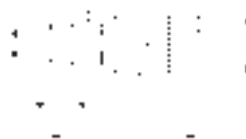
141

ENCHUFE MACHO - MALE SOCKET

Código Code	A	B	C	D	CH	Conf. Pack.
001410001	1/4	8	51	22	19	10
001410002	3/8	9	52	22	19	10
001410003	1/2	10	52.5	22	24	10

142

ENCHUFE HEMBRA - FEMALE SOCKET

Código Code	A	B	C	D	CH	Conf. Pack.
001420001	1/4	11	53	22	19	10
001420002	3/8	11.5	53.5	22	20	10
001420003	1/2	14	56	22	24	10

143

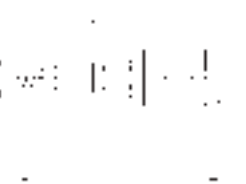
ENCHUFE TUBO CON MUELLE - COMPRESSION SOCKET WITH SPRING

Código Code	A	B	C	D	CH	Conf. Pack.
001430001	6/4	-	136	22	19	10
001430002	8/6	-	141.5	22	19	10
001430003	10/8	-	148	22	19	10

144

ENCHUFE TUBO - COMPRESSION SOCKET

Código Code	A	B	C	D	CH	Conf. Pack.
001440001	6/4	-	54	22	19	10
001440002	8/6	-	54	22	19	10
001440003	10/8	-	54	22	19	10

145

ENCHUFE ESPIGA - SOCKET WITH REST FOR RUBBER HOSE



Código Code	A	B	C	D	CH	Conf. Pack.
001450001	6	-	62.5	22	19	10
001450002	8	-	62.5	22	19	10
001450003	10	-	62.5	22	19	10
001450004	12	-	62.5	22	19	10

241

ADAPTADOR MACHO - MALE PLUG



Código Code	A	B	C	D	CH	Conf. Pack.
00241000103NB	1/4	8	41.5	-	17	25
00241000104NB	3/8	9	42.5	-	19	25
00241000105NB	1/2	10	44	-	24	25

241 AC

ADAPTADOR EN AVP MACHO - AVP MALE PLUG

**ACERO
STEEL**



Código Code	A	B	C	D	CH	Conf. Pack.
241AC005103ZI	1/4	8	41.5	-	17	25

242

ADAPTADOR HEMBRA - FEMALE PLUG

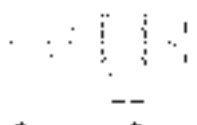

Código Code	A	B	C	D	CH	Conf. Pack.
00242000103NB	1/4	11	41.5	-	17	25
00242000104NB	3/8	11.5	42	-	19	25
00242000105NB	1/2	14	44.5	-	24	25

242 AC

ADAPTADOR EN AVP HEMBRA - AVP FEMALE PLUG

**ACERO
STEEL**



Código Code	A	B	C	D	CH	Conf. Pack.
242AC005103ZI	1/4	11	41.5	-	17	25

243

ADAPTADOR TUBO CON MUELLE - COMPRESSION PLUG WITH SPRING

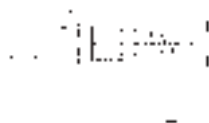

Código Code	A	B	C	D	CH	Conf. Pack.
0024300001	6/4	-	128	-	12	25
0024300002	8/6	-	133,5	-	13	25
0024300003	10/8	-	140	-	14	25

244

ADAPTADOR TUBO - COMPRESSION PLUG



Código Code	A	B	C	D	CH	Conf. Pack.
0024400001	6/4	-	46	-	12	25
0024400002	8/6	-	46	-	13	25
0024400003	10/8	-	48	-	14	25

245

ADAPTADOR ESPIGA - PLUG WITH REST FOR RUBBER HOSE

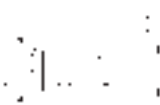

Código Code	A	B	C	D	CH	Conf. Pack.
002450001X4NB	6	-	48	10	-	25
002450001X7NB	8	-	51	12	-	25
002450001X9NB	10	-	51	14	-	25
002450001Y1NB	12	-	51	16	-	25

247

ADAPTADOR BAYONETA - BAYONET PLUG

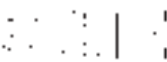

Código Code	A	B	C	D	CH	Conf. Pack.
0024700001	15	-	42	-	15	25

248

ADAPTADOR DE DESCARGA PROGRESIVA - PLUG WITH GRADUAL EXHAUST

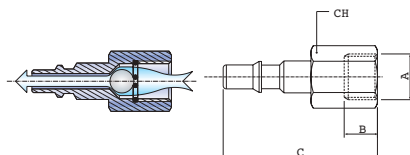

Código Code	A	B	C	CH	Conf. Pack.
0024800001	1/4	11	50	17	10

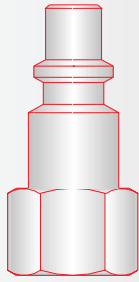

ITALIANO
1:1

120-250 SERIES Perfil Italiano

DN 5 mm

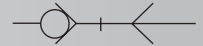

Presión de ejercicio / Working pressure: 0 - 16 bar

121

ENCHUFE MACHO - MALE SOCKET



Código Code	A	B	C	D	CH	Conf. Pack.
0012100001	1/4	8	53	24	21	10
0012100002	3/8	9	54	24	21	10
0012100003	1/2	10	55	24	24	10

122

ENCHUFE HEMBRA - FEMALE SOCKET



Código Code	A	B	C	D	CH	Conf. Pack.
0012200001	1/4	11	55	24	21	10
0012200002	3/8	11,5	55,5	24	21	10
0012200003	1/2	14	59	24	24	10

123

ENCHUFE TUBO CON MUELLE - COMPRESSION SOCKET WITH SPRING



Código Code	A	B	C	D	CH	Conf. Pack.
0012300001	6/4	-	141	24	21	10
0012300002	8/6	-	146,5	24	21	10
0012300003	10/8	-	154	24	21	10

124

ENCHUFE TUBO - COMPRESSION SOCKET

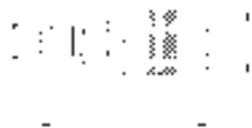

Código Code	A	B	C	D	CH	Conf. Pack.
0012400001	6/4	-	59	24	21	10
0012400002	8/6	-	59	24	21	10
0012400003	10/8	-	60	24	21	10

125

ENCHUFE ESPIGA - SOCKET WITH REST FOR RUBBER HOSE



Código Code	A	B	C	D	CH	Conf. Pack.
001250001	6	-	64	24	21	10
001250002	8	-	64	24	21	10
001250003	10	-	64	24	21	10
001250004	12	-	64	24	21	10

126

ENCHUFE CON PORTAGOMA - SOCKET FOR RUBBER HOSE



Código Code	A	B	C	D	CH	Conf. Pack.
001260001	14/6	-	72	24	21	10
001260002	17/8	-	72	24	21	10
001260003	19/10	-	72	24	21	10

251

ADAPTADOR MACHO - MALE PLUG



Código Code	A	B	C	D	CH	Conf. Pack.
00251000103NB	1/4	8	38	-	17	25
00251000104NB	3/8	9	39	-	19	25
00251000105NB	1/2	10	40.5	-	24	25

251AC

ADAPTADOR EN AVP MACHO - AVP MALE PLUG



**ACERO
STEEL**

Código Code	A	B	C	D	CH	Conf. Pack.
251AC005103ZI	1/4	8	38	-	17	25
251AC005104ZI	3/8	9	39	-	19	25
251AC005105ZI	1/2	10	40.5	-	24	25

252

ADAPTADOR HEMBRA - FEMALE PLUG



Código Code	A	B	C	D	CH	Conf. Pack.
00252000103NB	1/4	11	38	-	17	25
00252000104NB	3/8	11.5	38.5	-	19	25
00252000105NB	1/2	14	41	-	24	25

252AC

ADAPTADOR EN AVP HEMBRA - AVP FEMALE PLUG



**ACERO
STEEL**

Código Code	A	B	C	D	CH	Conf. Pack.
252AC005103ZI	1/4	11	38	-	17	25
252AC005104ZI	3/8	11.5	38.5	-	19	25
252AC005105ZI	1/2	14	41	-	24	25

253

ADAPTADOR TUBO CON MUELLE - COMPRESSION PLUG WITH SPRING

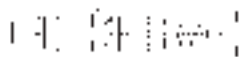

Código Code	A	B	C	D	CH	Conf. Pack.
0025300001	6/4	-	124.5	-	13	25
0025300002	8/6	-	130	-	13	25
0025300003	10/8	-	137.5	-	14	25
0025300004	12/10	-	143	-	16	25

254

ADAPTADOR TUBO - COMPRESSION PLUG



Código Code	A	B	C	D	CH	Conf. Pack.
0025400001	6/4	-	43.5	-	13	25
0025400002	8/6	-	43.5	-	13	25
0025400003	10/8	-	44.5	-	14	25
0025400004	12/10	-	46	-	16	25

255

ADAPTADOR ESPIGA - PLUG WITH REST FOR RUBBER HOSE



Código Code	A	B	C	D	CH	Conf. Pack.
002550001X4NB	6	-	44.5	12	-	25
002550001X7NB	8	-	44.5	12	-	25
002550001X9NB	10	-	47.5	14	-	25
002550001Y1NB	12	-	47.5	16	-	25

255AC

ADAPTADOR EN AVP ESPIGA - AVP PLUG WITH REST FOR RUBBER HOSE



Código Code	A	B	C	D	CH	Conf. Pack.
255AC0051X4ZI	6	-	44.5	12	-	25
255AC0051X7ZI	8	-	44.5	12	-	25
255AC0051X9ZI	10	-	47.5	14	-	25
255AC0051Y1ZI	12	-	47.5	16	-	25

**ACERO
STEEL**

256

ADAPTADOR CON PORTAGOMA - PLUG FOR RUBBER HOSE



Código Code	A	B	C	CH1	CH2	Conf. Pack.
0025600001	14/6	-	60	15	17	25
0025600002	17/8	-	60	15	20	25
0025600003	19/10	-	60	15	22	25

257

ADAPTADOR BAYONETA / BAYONET PLUG



Código Code	A	B	C	D	CH	Conf. Pack.
0025700001	15	-	38.5	-	15	25

258

ADAPTADOR DE DESCARGA PROGRESIVA - PLUG WITH GRADUAL EXHAUST

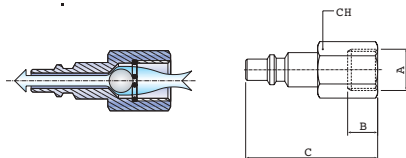

Código Code	A	B	C	CH	Conf. Pack.
0025800001	1/4	11	46.5	17	10

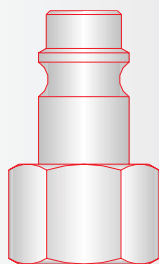
EUROPEO
1:1

160-260 SERIES

Perfil Europeo

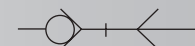
7,5 mm

Presión de ejercicio / Working pressure: 0 - 16 bar

161

ENCHUFE MACHO - MALE SOCKET



Código Code	A	B	C	D	CH	Conf. Pack.
0016100001	1/4	8	50	24	21	10
0016100002	3/8	9	54	24	21	10
0016100003	1/2	10	55	24	24	10

162

ENCHUFE HEMBRA - FEMALE SOCKET

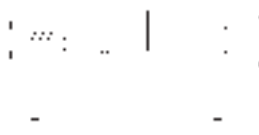

Código Code	A	B	C	D	CH	Conf. Pack.
0016200001	1/4	11	52	24	21	10
0016200002	3/8	11.5	52.5	24	21	10
0016200003	1/2	14	56	24	24	10

163

ENCHUFE TUBO CON MUELLE - COMPRESSION SOCKET WITH SPRING

Código Code	A	B	C	D	CH	Conf. Pack.
0016300001	6/4	-	138	24	21	10
0016300002	8/6	-	143.5	24	21	10
0016300003	10/8	-	151	24	21	10
0016300007	12/10	-	161.5	24	21	10

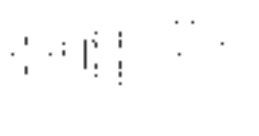
164

ENCHUFE TUBO - COMPRESSION SOCKET

Código Code	A	B	C	D	CH	Conf. Pack.
0016400001	6/4	-	59	24	21	10
0016400002	8/6	-	59	24	21	10
0016400003	10/8	-	60	24	21	10
0016400007	12/10	-	62	24	21	10

165

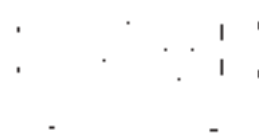
ENCHUFE ESPIGA - SOCKET WITH REST FOR RUBBER HOSE

Código Code	A	B	C	D	CH	Conf. Pack.
0016500001	6	-	61	24	21	10
0016500002	8	-	61	24	21	10
0016500003	10	-	61	24	21	10
0016500004	12	-	61	24	21	10

166

ENCHUFE CON PORTAGOMA - SOCKET FOR RUBBER HOSE

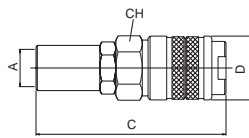

Código Code	A	B	C	D	CH	Conf. Pack.
001660001	14/6	-	80	24	21	10
001660002	17/8	-	84	24	21	10
001660003	19/10	-	85	24	24	10

261

ADAPTADOR MACHO - MALE PLUG

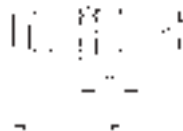

Código Code	A	B	C	D	CH	Conf. Pack.
00261000103NB	1/4	8	33	-	17	25
00261000104NB	3/8	9	34	-	19	25
00261000105NB	1/2	10	35.5	-	24	25

261AC

ADAPTADOR EN AVP MACHO - AVP MALE PLUG



**ACERO
STEEL**

Código Code	A	B	C	D	CH	Conf. Pack.
261AC005103ZI	1/4	8	33	-	17	25
261AC005104ZI	3/8	9	34	-	19	25
261AC005105ZI	1/2	10	35.5	-	24	25

262

ADAPTADOR HEMBRA - FEMALE PLUG

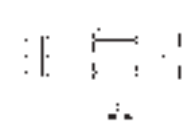

Código Code	A	B	C	D	CH	Conf. Pack.
00262000103NB	1/4	11	33	-	17	25
00262000104NB	3/8	11.5	33.5	-	19	25
00262000105NB	1/2	14	36	-	24	25

262AC

ADAPTADOR EN AVP HEMBRA - AVP FEMALE PLUG

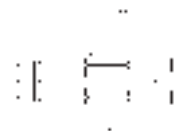

**ACERO
STEEL**

Código Code	A	B	C	D	CH	Conf. Pack.
262AC005103ZI	1/4	11	33	-	17	25
262AC005104ZI	3/8	11.5	33.5	-	19	25
262AC005105ZI	1/2	14	36	-	24	25

263

ADAPTADOR TUBO CON MUELLE - COMPRESSION PLUG WITH SPRING

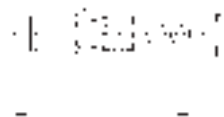

Código Code	A	B	C	D	CH	Conf. Pack.
0026300001	6/4	-	124.5	-	13	25
0026300002	8/6	-	130	-	13	25
0026300003	10/8	-	137.5	-	14	25
0026300004	12/10	-	143	-	16	25

264

ADAPTADOR TUBO - COMPRESSION PLUG



Código Code	A	B	C	D	CH	Conf. Pack.
0026400001	6/4	-	36	-	13	25
0026400002	8/6	-	36.5	-	13	25
0026400003	10/8	-	38.5	-	14	25
0026400004	12/10	-	47.5	-	16	25

265

ADAPTADOR ESPIGA - PLUG WITH REST FOR RUBBER HOSE

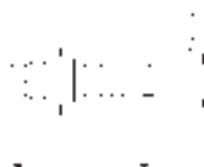

Código Code	A	B	C	D	CH	Conf. Pack.
002650001X4NB	6	-	39.5	12	-	25
002650001X7NB	8	-	39.5	12	-	25
002650001X9NB	10	-	42.5	14	-	25
002650001Y1NB	12	-	42.5	16	-	25

265AC

ADAPTADOR EN AVP ESPIGA - AVP PLUG WITH REST FOR RUBBER HOSE

**ACERO
STEEL**

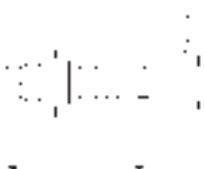

Código Code	A	B	C	D	CH	Conf. Pack.
265AC0051X4ZI	6	-	39.5	12	-	25
265AC0051X7ZI	8	-	39.5	12	-	25
265AC0051X9ZI	10	-	42.5	14	-	25
265AC0051Y1ZI	12	-	42.5	16	-	25

266

ADAPTADOR CON PORTAGOMA - PLUG FOR RUBBER HOSE

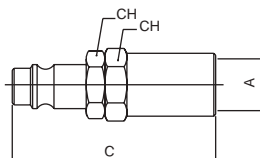

Código Code	A	B	C	CH1	CH2	Conf. Pack.
0026600001	14/6	-	55	15	17	25
0026600002	17/8	-	55	15	20	25
0026600003	19/10	-	55	15	22	25

267

ADAPTADOR BAYONETA - BAYONET PLUG



Código Code	A	B	C	D	CH	Conf. Pack.
0026700001	15	-	33.5	-	15	25

268

ADAPTADOR DE DESCARGA PROGRESIVA - PLUG WITH GRADUAL EXHAUST

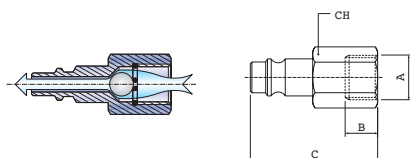

Código Code	A	B	C	CH	Conf. Pack.
0026800001	1/4	11	41.5	17	10

180-280 SERIES

Perfil Mignon

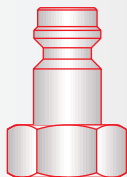

MIGNON
1:1



5 mm

ENCHUFES RÁPIDOS DE DOBLE OBTURACIÓN
AUTOMATIC QUICK COUPLINGS WITH DOUBLE SHUT-OFF

Presión de ejercicio / Working pressure: 0 - 12 bar

181

ENCHUFE MACHO PARA ADAPTADOR OBTURADO - MALE SOCKET FOR SHUTTER PLUG

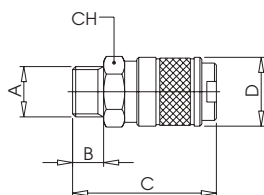

Código Code	A	B	C	D	CH	Conf. Pack.
0018100001	1/8	6	35.5	18	16	10
0018100002	1/4	8	37.5	18	16	10
0018100003	3/8	9	38.5	18	19	10

182

ENCHUFE HEMBRA PARA ADAPTADOR OBTURADO - FEMALE SOCKET FOR SHUTTER PLUG

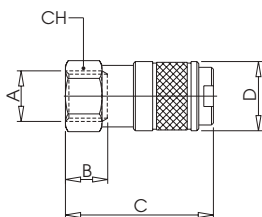

Código Code	A	B	C	D	CH	Conf. Pack.
0018200001	1/8	7.5	35	18	16	10
0018200002	1/4	11	38.5	18	16	10
0018200003	3/8	11.5	39	18	19	10

183

ENCHUFE TUBO CON MUELLE PARA ADAPTADOR OBTURADO - COMPRESSION SOCKET WITH NUT AND SPRING FOR SHUTTER PLUG

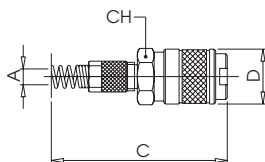

Código Code	A	B	C	D	CH	Conf. Pack.
0018300001	6/4	-	124	18	16	10
0018300002	8/6	-	129.5	18	16	10

184

ENCHUFE TUBO PARA ADAPTADOR OBTURADO - COMPRESSION SOCKET FOR SHUTTER PLUG

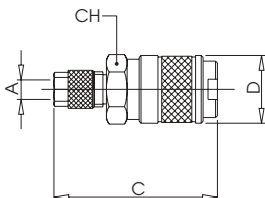

Código Code	A	B	C	D	CH	Conf. Pack.
0018400001	6/4	-	42	18	16	10
0018400002	8/6	-	42	18	16	10

185

ENCHUFE ESPIGA PARA ADAPTADOR OBTURADO - SOCKET WITH REST FOR RUBBER HOSE FOR SHUTTER PLUG

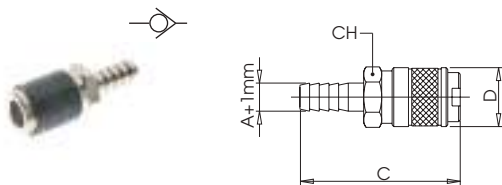

Código Code	A	B	C	D	CH	Conf. Pack.
001850001	4	-	48	18	16	10
001850002	6	-	48	18	16	10
001850003	8	-	48	18	16	10

281

ADAPTADOR OBTURADO MACHO - MALE SHUTTER PLUG

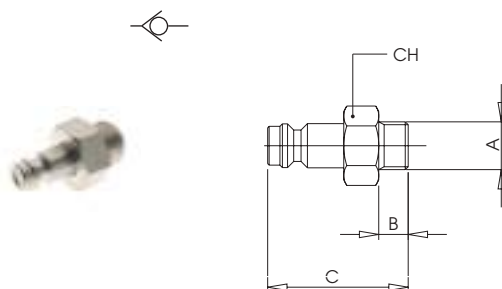

Código Code	A	B	C	D	CH	Conf. Pack.
0028100001	1/8	6	29.5	-	14	25
0028100002	1/4	8	31.5	-	17	25
0028100003	3/8	9	32.5	-	19	25

UTILIZAR SOLO CON ENCHUFES PARA ADAPTADOR OBTURADO
USING ONLY WITH SOCKET FOR SHUTTER PLUG

282

ADAPTADOR OBTURADO HEMBRA - FEMALE SHUTTER PLUG

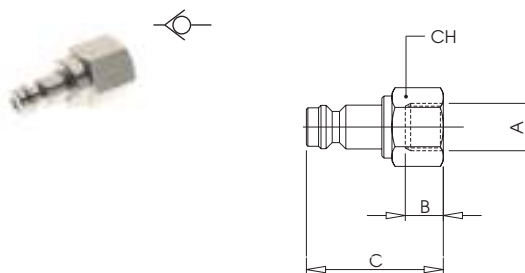

Código Code	A	B	C	D	CH	Conf. Pack.
0028200001	1/8	7.5	31.5	-	14	25
0028200002	1/4	11	35	-	17	25
0028200003	3/8	11.5	35.5	-	19	25

UTILIZAR SOLO CON ENCHUFES PARA ADAPTADOR OBTURADO
USING ONLY WITH SOCKET FOR SHUTTER PLUG

283

ADAPTADOR OBTURADO TUBO CON MUELLE - COMPRESSION SHUTTER PLUG WITH NUT AND SPRING



Código Code	A	B	C	D	CH	Conf. Pack.
0028300001	6/4	-	118.5	-	12	25
0028300002	8/6	-	122	-	12	25

UTILIZAR SOLO CON ENCHUFES PARA ADAPTADOR OBTURADO
USING ONLY WITH SOCKET FOR SHUTTER PLUG

284

ADAPTADOR OBTURADO TUBO - COMPRESSION SHUTTER PLUG

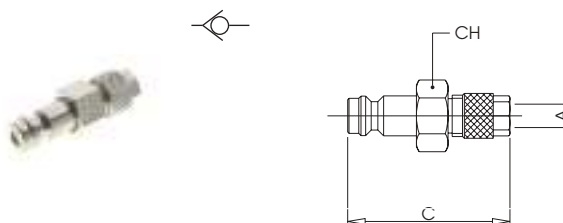

Código Code	A	B	C	D	CH	Conf. Pack.
0028400001	6/4	-	36.5	-	12	25
0028400002	8/6	-	36.5	-	12	25

UTILIZAR SOLO CON ENCHUFES PARA ADAPTADOR OBTURADO
USING ONLY WITH SOCKET FOR SHUTTER PLUG

285

ADAPTADOR OBTURADO ESPIGA - SHUTTER PLUG WITH REST FOR RUBBER HOSE

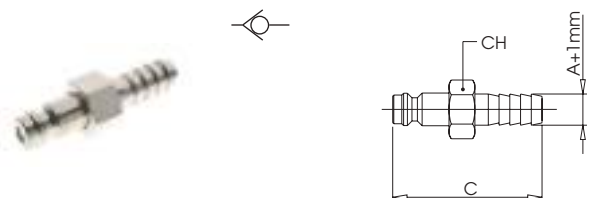

Código Code	A	B	C	D	CH	Conf. Pack.
0028500001	4	-	43.5	-	11	25
0028500002	6	-	43.5	-	11	25
0028500003	8	-	43.5	-	13	25

UTILIZAR SOLO CON ENCHUFES PARA ADAPTADOR OBTURADO
USING ONLY WITH SOCKET FOR SHUTTER PLUG

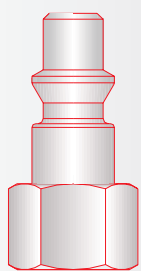

SUECO
1:1

270 SERIES

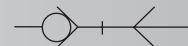
Perfil Sueco

5,5 mm

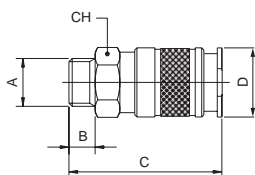
Presión de ejercicio / Working pressure: 0 - 16 bar

191

ENCHUFE MACHO - MALE SOCKET

Código Code	A	B	C	D	CH	Conf. Pack.
0019100001	1/4	8	49	24	21	10
0019100002	3/8	9	50	24	21	10
0019100003	1/2	10	51	24	24	10

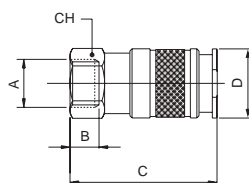
192

ENCHUFE HEMBRA - FEMALE SOCKET

Código Code	A	B	C	D	CH	Conf. Pack.
0019200001	1/4	11	51	24	21	10
0019200002	3/8	11,5	51	24	21	10
0019200003	1/2	14	55	24	24	10

193

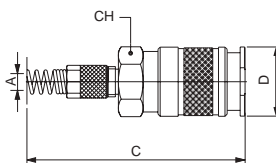
ENCHUFE TUBO CON MUELLE - COMPRESSION SOCKET WITH SPRING

Código Code	A	B	C	D	CH	Conf. Pack.
0019300001	6/4	-	138	24	21	10
0019300002	8/6	-	144,5	24	21	10
0019300004	10/6.5	-	153,5	24	21	10
0019300003	10/8	-	153,5	24	21	10
0019300005	12/10	-	159	24	21	10

194

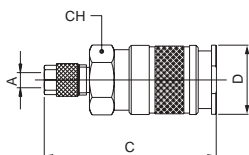
ENCHUFE TUBO - COMPRESSION SOCKET

Código Code	A	B	C	D	CH	Conf. Pack.
0019400001	6/4	-	55	24	21	10
0019400002	8/6	-	55	24	21	10
0019400003	10/8	-	55	24	21	10
0019400007	12/10	-	57,5	24	21	10

195

ENCHUFE ESPIGA - SOCKET WITH REST FOR RUBBER HOSE

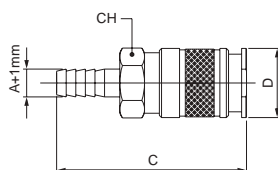

Código Code	A	B	C	D	CH	Conf. Pack.
001950001	6	-	61	24	21	10
001950002	8	-	61	24	21	10
001950003	10	-	61	24	21	10
001950004	12	-	61	24	21	10

196

ENCHUFE CON PORTAGOMA - SOCKET FOR RUBBER HOSE

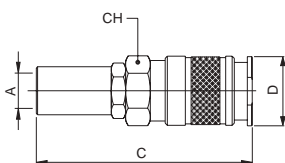

Código Code	A	B	C	D	CH	Conf. Pack.
001960001	14/6	-	71	24	21	10
001960002	17/8	-	71	24	21	10
001960003	19/10	-	71	24	21	10

271

ADAPTADOR MACHO - MALE PLUG

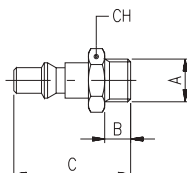

Código Code	A	B	C	D	CH	Conf. Pack.
00271000103NB	1/4	8	36	-	17	25
00271000104NB	3/8	9	37	-	19	25
00271000105NB	1/2	10	38.5	-	24	25

271AC

ADAPTADOR EN AVP MACHO - AVP MALE PLUG

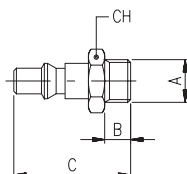

Código Code	A	B	C	D	CH	Conf. Pack.
271AC005103ZI	1/4	8	36	-	17	25
271AC005104ZI	3/8	9	37	-	19	25
271AC005105ZI	1/2	10	38.5	-	24	25

**ACERO
STEEL**

272

ADAPTADOR HEMBRA - FEMALE PLUG

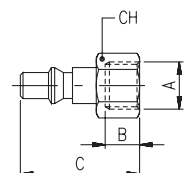

Código Code	A	B	C	D	CH	Conf. Pack.
00272000103NB	1/4	11	36	-	17	25
00272000104NB	3/8	11.5	36.5	-	19	25
00272000105NB	1/2	14	39	-	24	25

272AC

ADAPTADOR EN AVP HEMBRA - AVP FEMALE PLUG

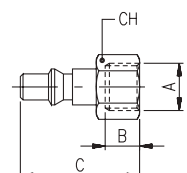

Código Code	A	B	C	D	CH	Conf. Pack.
272AC005103ZI	1/4	11	36	-	17	25
272AC005104ZI	3/8	11.5	36.5	-	19	25
272AC005105ZI	1/2	14	39	-	24	25

**ACERO
STEEL**

273

ADAPTADOR TUBO CON MUELLE - COMPRESSION PLUG WITH SPRING

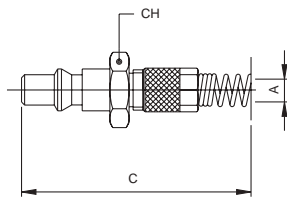

Código Code	A	B	C	D	CH	Conf. Pack.
0027300001	6/4	-	122.5	-	13	25
0027300002	8/6	-	128	-	13	25
0027300003	10/8	-	135.5	-	14	25
0027300004	12/10	-	146	-	16	25

274

ADAPTADOR TUBO - COMPRESSION PLUG

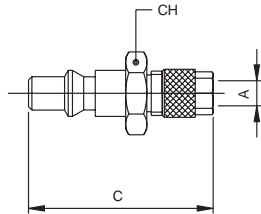

Código Code	A	B	C	D	CH	Conf. Pack.
0027400001	6/4	-	41.5	-	13	25
0027400002	8/6	-	41.5	-	13	25
0027400003	10/8	-	42.5	-	14	25
0027400004	12/10	-	44.5	-	16	25

275

ADAPTADOR ESPIGA - PLUG WITH REST FOR RUBBER HOSE

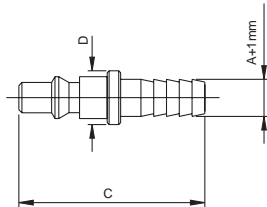

Código Code	A	B	C	D	CH	Conf. Pack.
002750001X4NB	6	-	42.5	11	-	25
002750001X7NB	8	-	42.5	11	-	25
002750001X9NB	10	-	45.5	14	-	25
002750001Y1NB	12	-	45.5	16	-	25

275AC

ADAPTADOR EN AVP ESPIGA - AVP PLUG WITH REST FOR RUBBER HOSE

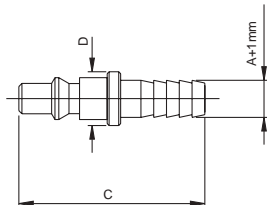

Código Code	A	B	C	D	CH	Conf. Pack.
275AC0051X4ZI	6	-	42.5	11	-	25
275AC0051X7ZI	8	-	42.5	11	-	25
275AC0051X9ZI	10	-	45.5	14	-	25
275AC0051Y1ZI	12	-	45.5	16	-	25

**ACERO
STEEL**

277

ADAPTADOR BAYONETA - BAYONET PLUG

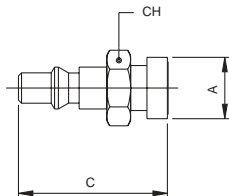

Código Code	A	B	C	D	CH	Conf. Pack.
0027700001	15	-	36.5	-	15	25

278

ADAPTADOR DE DESCARGA PROGRESIVA - PLUG WITH GRADUAL EXHAUST

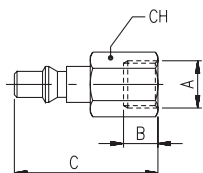
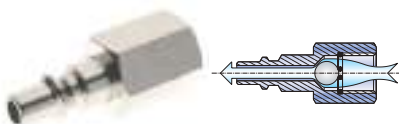

Código Code	A	B	C	CH	Conf. Pack.
0027800001	1/4	11	44.5	17	10

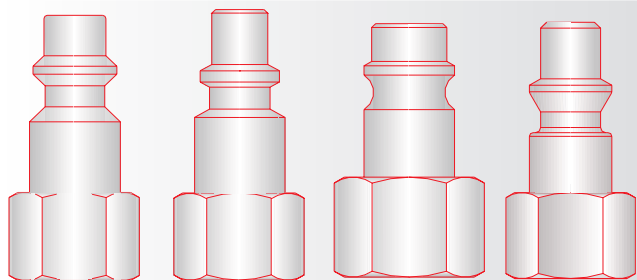
Serie 220
B-12
 1:1

Serie 250
ITALIANO
 1:1

Serie 260
EUROPEO
 1:1

Serie 270
SUECO
 1:1

SERIE 190

MULTIPRESA

MULTISOCKET

UN ÚNICO ENCHUFE PARA 4 TIPOS DE ADAPTADOR
ONE SOCKET FOR 4 DIFFERENT PLUGS

Presión de ejercicio / Working pressure: 0 - 16 bar

Es un dato a remarcar que en el mercado existen varios tipos de adaptadores distintos, ya sea en la forma como en las dimensiones, que generalmente necesitan de enchufes específicos no intercambiables entre ellos. Para solucionar este problema AIGNEP propone una solución práctica y económica de intercambiabilidad con todos los adaptadores homologados en el mercado europeo, garantizando para todos una perfecta estanqueidad.

It is a matter of fact that on the market are available various types of plugs well distinguished whether on the shape or on the dimensions, usually they need to be assembled with specific sockets which normally are not interchangeable. To get round to this incompatibility AIGNEP is proud to offer to its customers a practical and cost-effective solution, a unique socket to be used with 4 different types of plugs, ensuring a perfect tightening.



Perfil
Standard SUECO
Serie 270
 (DN) 5,5 mm

VER PAG 12.27 - SEE PAG 12.27

Perfil
UNI ISO 6150 B-12
Serie 220
 (DN) 5,5 mm

VER PAG 12.10 - SEE PAG 12.10

Perfil
Standard EUROPEO
Serie 260
 (DN) 7,5 mm

VER PAG 12.22 - SEE PAG 12.22

Perfil
Standard ITALIANO
Serie 250
 (DN) 5 mm

VER PAG 12.19 - SEE PAG 12.19

191

ENCHUFE MACHO - MALE SOCKET

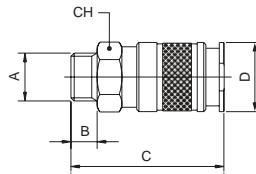

Código Code	A	B	C	D	CH	Conf. Pack.
0019100001	1/4	8	49	24	21	10
0019100002	3/8	9	50	24	21	10
0019100003	1/2	10	51	24	24	10

192

ENCHUFE HEMBRA - FEMALE SOCKET

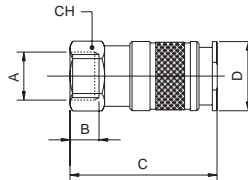

Código Code	A	B	C	D	CH	Conf. Pack.
0019200001	1/4	11	51	24	21	10
0019200002	3/8	11.5	51	24	21	10
0019200003	1/2	14	55	24	24	10

193

ENCHUFE TUBO CON MUELLE - COMPRESSION SOCKET WITH SPRING

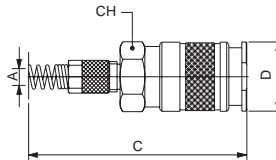

Código Code	A	B	C	D	CH	Conf. Pack.
0019300001	6/4	-	138	24	21	10
0019300002	8/6	-	144.5	24	21	10
0019300004	10/6.5	-	153.5	24	21	10
0019300003	10/8	-	153.5	24	21	10
0019300005	12/10	-	159	24	21	10

194

ENCHUFE TUBO - COMPRESSION SOCKET

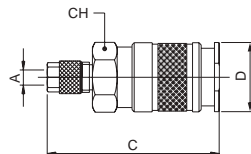

Código Code	A	B	C	D	CH	Conf. Pack.
0019400001	6/4	-	55	24	21	10
0019400002	8/6	-	55	24	21	10
0019400003	10/8	-	55	24	21	10
0019400007	12/10	-	57.5	24	21	10

195

ENCHUFE ESPIGA - SOCKET WITH REST FOR RUBBER HOSE

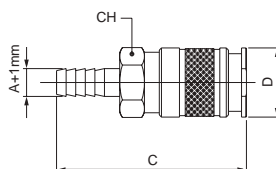

Código Code	A	B	C	D	CH	Conf. Pack.
0019500001	6	-	61	24	21	10
0019500002	8	-	61	24	21	10
0019500003	10	-	61	24	21	10
0019500004	12	-	61	24	21	10

196

ENCHUFE CON PORTAGOMA - SOCKET FOR RUBBER HOSE

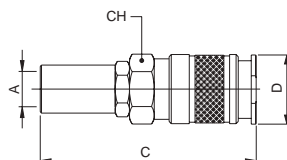

Código Code	A	B	C	D	CH	Conf. Pack.
0019600001	14/6	-	71	24	21	10
0019600002	17/8	-	71	24	21	10
0019600003	19/10	-	71	24	21	10

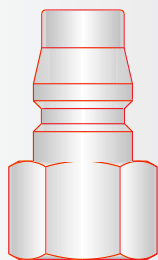

JAPONÉS
1:1

400-500 SERIES

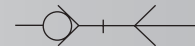
Perfil Japonés

7,5 mm

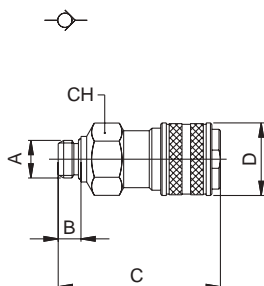
Presión de ejercicio / Working pressure: 0 - 25 bar

401

ENCHUFE MACHO - MALE SOCKET

Código Code	A	B	C	D	CH	Conf. Pack.
0040100001	1/4	8	57	25.5	22	10
0040100002	3/8	9	58	25.5	22	10
0040100003	1/2	10	58	25.5	25	10

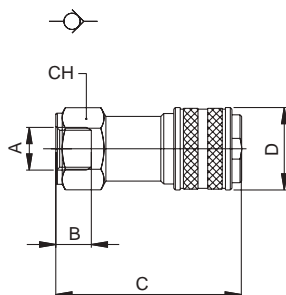
402

ENCHUFE HEMBRA - FEMALE SOCKET

Código Code	A	B	C	D	CH	Conf. Pack.
0040200001	1/4	11	57.5	25.5	22	10
0040200002	3/8	12	58.5	25.5	22	10
0040200003	1/2	15	61.5	25.5	24	10

405

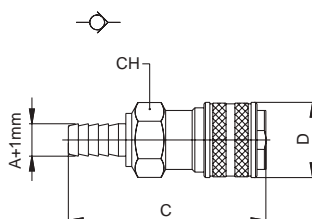
ENCHUFE ESPIGA - SOCKET WITH REST FOR RUBBER HOSE

Código Code	A	C	D	CH	Conf. Pack.
0040500002	8	67	25.5	22	10
0040500003	10	67	25.5	22	10
0040500004	12	67	25.5	22	10

501AC

ADAPTADOR EN AVP MACHO - AVP MALE PLUG

ACERO
STEEL

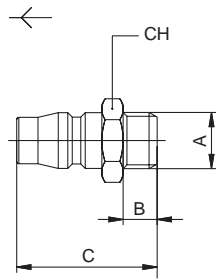

Código Code	A	B	C	CH	Conf. Pack.
501AC005103ZI	1/4	8	33	17	25
501AC005104ZI	3/8	9	34	19	25
501AC005105ZI	1/2	10	35.5	24	25

502AC

ADAPTADOR EN AVP HEMBRA - AVP FEMALE PLUG

ACERO
STEEL

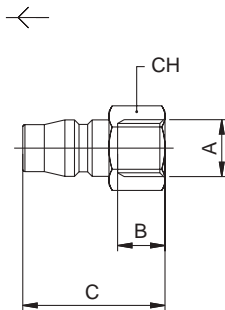

Código Code	A	B	C	CH	Conf. Pack.
502AC005103ZI	1/4	11	33	17	25
502AC005104ZI	3/8	12	33.5	19	25
502AC005105ZI	1/2	15	37	24	25

505AC

ADAPTADOR EN AVP ESPIGA - AVP PLUG WITH REST FOR RUBBER HOSE

ACERO
STEEL

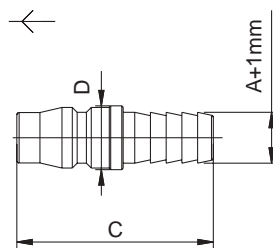

Código Code	A+1mm	C	D	Conf. Pack.
505AC0051X7ZI	8	39.5	13	25
505AC0051X9ZI	10	42.5	14	25
505AC0051Y1ZI	12	42.5	16	25

600 SERIES - SAFETY QUICK COUPLINGS

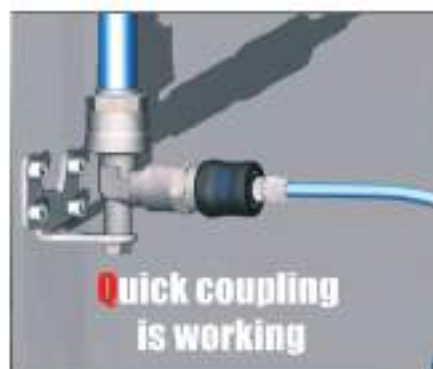

ONE TOUCH



Características Técnicas / Technical Characteristics



Aconsejados con adaptadores AVP (Acero)
Advise with AVP plug

Materiales y Componentes / Component Parts and Materials

- | | |
|--|---|
| 1 Junta tórica en NBR 70 | 1 NBR 70 O-ring |
| 2 Muelle empuje obturador en acero INOX AISI 302 | 2 INOX steel AISI 302 shutter thrust spring |
| 3 Obturador en latón niquelado | 3 Nickel-plated brass shutter |
| 4 Junta en NBR 70 | 4 NBR 70 seal |
| 5 Anillo en latón niquelado | 5 Nickel-plated brass ring |
| 6 Junta tórica en NBR 70 | 6 NBR 70 O-ring |
| 7 Muelle empuje tuerca en acero INOX AISI 302 | 7 INOX steel AISI 302 ring nut thrust spring |
| 8 Anillo deslizamiento perno en tecnopolímero | 8 Technopolymeric trailing pins ring |
| 9 Perno en acero INOX AISI 420 | 9 INOX steel AISI 420 pin |
| 10 Esfera en acero INOX AISI 420 | 10 INOX steel AISI 420 ball |
| 11 Anillo contención esfera en acero INOX AISI 303 | 11 INOX steel AISI 303 restraining balls ring |
| 12 Seeger en acero INOX AISI 302 | 12 INOX steel AISI 302 seeger |
| 13 Cuerpo en tecnopolímero | 13 Technopolymeric Body |
| 14 Tuerca en tecnopolímero | 14 Technopolymeric sleeve |
| 15 Terminal en latón niquelado | 15 Nickel-plated brass coupling back part |

Presiones / Pressures

Presión mínima / Minimum pressure: **-0.99 bar** (-0.099 MPa)
 Presión máxima / Maximum pressure: **15 bar** (1.5 MPa)

Temperaturas / Temperatures

Temperatura mínima / Minimum temperature: **-18 °C**
 Temperatura máxima / Maximum temperature: **+80 °C**

Roscas / Threads

Gas cilíndrica conforme ISO 228 Clase A / Parallel gas in conformity with ISO 228 Class A.

Tubos de conexión / Connection Tubes

Tubos en material plástico:
 PA6, PA11, PA12, Polietileno, *Poliuretano etc...
 *(para tubos en Poliuretano se aconseja una dureza de 98 shore).
 Plastic tubes:
 PA6, PA11, PA12, Polyethylene, *Polyurethane, ecc.
 *For Polyurethane hoses it is required a minimum hardness of 98 shore.

Fluidos compatibles / Fluids

Aire comprimido / Compressed air.

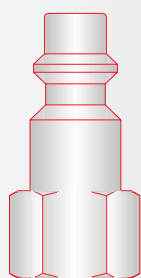

B-12
1:1

620 SERIES UNI ISO 6150 B-12

DN 5,5 mm

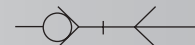

Presión de ejercicio / Working pressure: 0 - 15 bar

621

ENCHUFE MACHO - MALE SOCKET

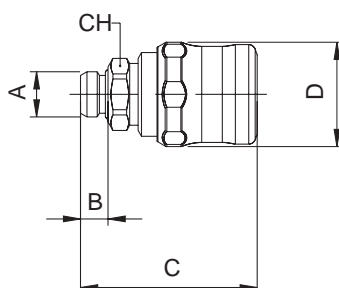

Código Code	A	B	C	D	CH	Conf. Pack.
0062100001	1/4	8	51.5	30.5	19	10
0062100002	3/8	9	52	30.5	20	10
0062100003	1/2	10	53	30.5	25	10

622

ENCHUFE HEMBRA - FEMALE SOCKET

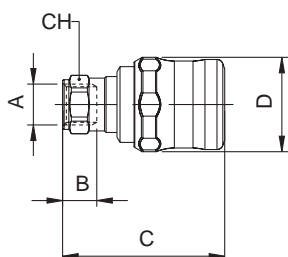

Código Code	A	B	C	D	CH	Conf. Pack.
0062200001	1/4	11	52	30.5	17	10
0062200002	3/8	12	53	30.5	20	10
0062200003	1/2	15	56	30.5	24	10

624

ENCHUFE TUBO - COMPRESSION SOCKET

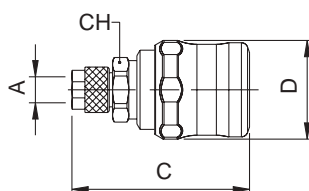

Código Code	A	B	C	D	CH	Conf. Pack.
0062400001	6/4	-	55	30.5	18	10
0062400002	8/6	-	54.5	30.5	18	10
0062400005	10/6.5	-	57.5	30.5	18	10
0062400003	10/8	-	56.5	30.5	18	10
0062400006	12/8	-	58	30.5	18	10
0062400004	12/10	-	57	30.5	18	10

625

ENCHUFE ESPIGA - SOCKET WITH REST FOR RUBBER HOSE

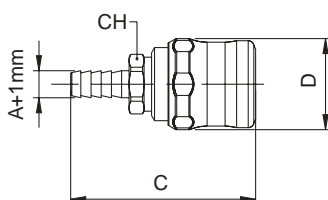

Código Code	A	B	C	D	CH	Conf. Pack.
0062500001	6	-	61.5	30.5	18	10
0062500002	8	-	61.5	30.5	18	10
0062500003	10	-	61.5	30.5	18	10
0062500004	12	-	61.5	30.5	18	10

221AC

ADAPTADOR EN AVP MACHO - AVP MALE PLUG

ACERO
STEEL



Código Code	A	B	C	D	CH	Conf. Pack.
221AC005103ZI	1/4	8	36.5	-	17	25
221AC005104ZI	3/8	9	37.5	-	19	25
221AC005105ZI	1/2	10	39	-	24	25

222AC

ADAPTADOR EN AVP HEMBRA - AVP FEMALE PLUG

ACERO
STEEL



Código Code	A	B	C	D	CH	Conf. Pack.
222AC005103ZI	1/4	11	36.5	-	17	25
222AC005104ZI	3/8	11.5	37	-	19	25
222AC005105ZI	1/2	14	39.5	-	24	25

225AC

ADAPTADOR EN AVP ESPIGA - AVP PLUG WITH REST FOR RUBBER HOSE

ACERO
STEEL



Código Code	A	B	C	D	CH	Conf. Pack.
225AC0051X4ZI	6	-	43.5	12	-	25
225AC0051X7ZI	8	-	43.5	12	-	25
225AC0051X9ZI	10	-	46	14	-	25
225AC0051Y1ZI	12	-	46	16	-	25

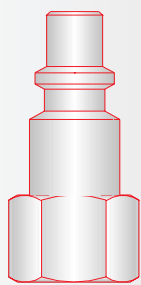

ITALIANO
1:1

650 SERIES

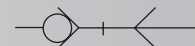
ITALIANO

5 mm

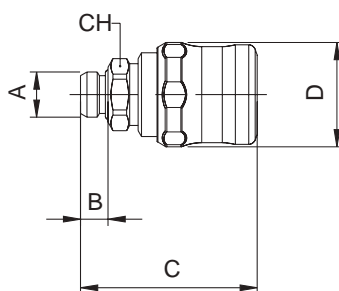
Presión de ejercicio / Working pressure: 0 - 15 bar

651

ENCHUFE MACHO - MALE SOCKET

Código Code	A	B	C	D	CH	Conf. Pack.
0065100001	1/4	8	52.5	30.5	19	10
0065100002	3/8	9	53	30.5	20	10
0065100003	1/2	10	54	30.5	25	10

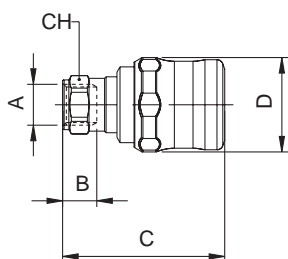
652

ENCHUFE HEMBRA - FEMALE SOCKET

Código Code	A	B	C	D	CH	Conf. Pack.
0065200001	1/4	11	53	30.5	17	10
0065200002	3/8	12	54	30.5	20	10
0065200003	1/2	15	57	30.5	24	10

654

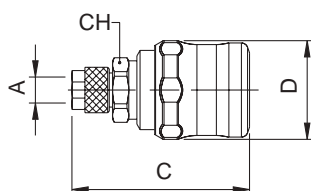
ENCHUFE TUBO - COMPRESSION SOCKET

Código Code	A	B	C	D	CH	Conf. Pack.
0065400001	6/4	-	56	30.5	18	10
0065400002	8/6	-	55.5	30.5	18	10
0065400005	10/6.5	-	58.5	30.5	18	10
0065400003	10/8	-	57.5	30.5	18	10
0065400006	12/8	-	59	30.5	18	10
0065400004	12/10	-	58	30.5	18	10

655

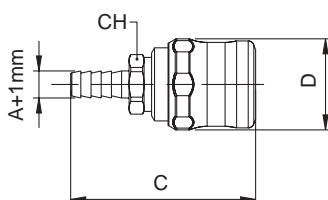
ENCHUFE ESPIGA - SOCKET WITH REST FOR RUBBER HOSE

Código Code	A	B	C	D	CH	Conf. Pack.
0065500001	6	-	62.5	30.5	18	10
0065500002	8	-	62.5	30.5	18	10
0065500003	10	-	62.5	30.5	18	10
0065500004	12	-	62.5	30.5	18	10

251AC

ADAPTADOR EN AVP MACHO - AVP MALE PLUG



ACERO
STEEL

Código Code	A	B	C	D	CH	Conf. Pack.
251AC005103ZI	1/4	8	38	-	17	25
251AC005104ZI	3/8	9	39	-	19	25
251AC005105ZI	1/2	10	40.5	-	24	25

252AC

ADAPTADOR EN AVP HEMBRA - AVP FEMALE PLUG



ACERO
STEEL

Código Code	A	B	C	D	CH	Conf. Pack.
252AC005103ZI	1/4	11	38	-	17	25
252AC005104ZI	3/8	11.5	38.5	-	19	25
252AC005105ZI	1/2	14	41	-	24	25

255AC

ADAPTADOR EN AVP ESPIGA - AVP PLUG WITH REST FOR RUBBER HOSE

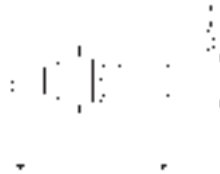

ACERO
STEEL

Código Code	A	B	C	D	CH	Conf. Pack.
255AC0051X4ZI	6	-	44.5	12	-	25
255AC0051X7ZI	8	-	44.5	12	-	25
255AC0051X9ZI	10	-	47.5	14	-	25
255AC0051Y1ZI	12	-	47.5	16	-	25

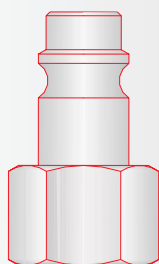

EUROPEO
1:1

660 SERIES EUROPEO

DN 7,5 mm

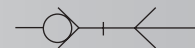

Presión de ejercicio / Working pressure: 0 - 15 bar

661

ENCHUFE MACHO - MALE SOCKET

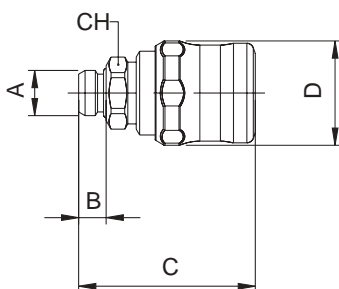

Código Code	A	B	C	D	CH	Conf. Pack.
0066100001	1/4	8	51	30.5	19	10
0066100002	3/8	9	51.5	30.5	20	10
0066100003	1/2	10	52.5	30.5	25	10

662

ENCHUFE HEMBRA - FEMALE SOCKET

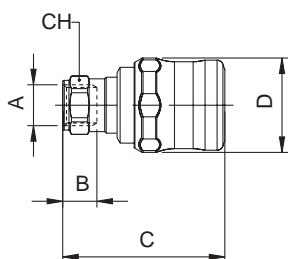

Código Code	A	B	C	D	CH	Conf. Pack.
0066200001	1/4	11	51.5	30.5	17	10
0066200002	3/8	12	52.5	30.5	20	10
0066200003	1/2	15	55.5	30.5	24	10

664

ENCHUFE TUBO - COMPRESSION SOCKET

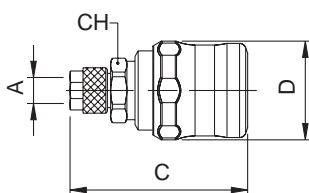

Código Code	A	B	C	D	CH	Conf. Pack.
0066400001	6/4	-	54.5	30.5	18	10
0066400002	8/6	-	54	30.5	18	10
0066400005	10/6.5	-	57	30.5	18	10
0066400003	10/8	-	56	30.5	18	10
0066400006	12/8	-	57.5	30.5	18	10
0066400004	12/10	-	56.5	30.5	18	10

665

ENCHUFE ESPIGA - SOCKET WITH REST FOR RUBBER HOSE

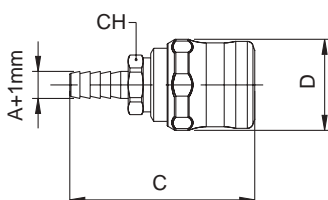

Código Code	A	B	C	D	CH	Conf. Pack.
0066500001	6	-	61	30.5	18	10
0066500002	8	-	61	30.5	18	10
0066500003	10	-	61	30.5	18	10
0066500004	12	-	61	30.5	18	10

261AC

ADAPTADOR EN AVP MACHO - AVP MALE PLUG



ACERO
STEEL

Código Code	A	B	C	D	CH	Conf. Pack.
261AC005103ZI	1/4	8	33	-	17	25
261AC005104ZI	3/8	9	34	-	19	25
261AC005105ZI	1/2	10	35.5	-	24	25

262AC

ADAPTADOR EN AVP HEMBRA - AVP FEMALE PLUG

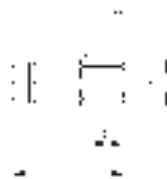

ACERO
STEEL

Código Code	A	B	C	D	CH	Conf. Pack.
262AC005103ZI	1/4	11	33	-	17	25
262AC005104ZI	3/8	11.5	33.5	-	19	25
262AC005105ZI	1/2	14	36	-	24	25

265AC

ADAPTADOR EN AVP ESPIGA - AVP PLUG WITH REST FOR RUBBER HOSE

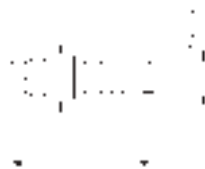

ACERO
STEEL

Código Code	A	B	C	D	CH	Conf. Pack.
265AC0051X4ZI	6	-	39.5	12	-	25
265AC0051X7ZI	8	-	39.5	12	-	25
265AC0051X9ZI	10	-	42.5	14	-	25
265AC0051Y1ZI	12	-	42.5	16	-	25

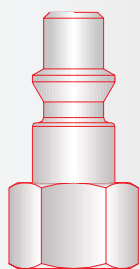

SUECO
1:1

670 SERIES

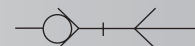
SUECO

DN 5,5 mm

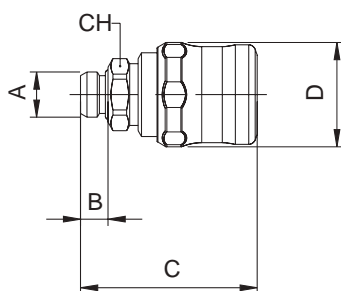
Presión de ejercicio / Working pressure: 0 - 15 bar

671

ENCHUFE MACHO - MALE SOCKET

Código Code	A	B	C	D	CH	Conf. Pack.
0067100001	1/4	8	51.5	30.5	19	10
0067100002	3/8	9	52	30.5	20	10
0067100003	1/2	10	53	30.5	25	10

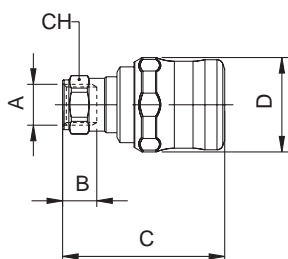
672

ENCHUFE HEMBRA - FEMALE SOCKET

Código Code	A	B	C	D	CH	Conf. Pack.
0067200001	1/4	11	52	30.5	17	10
0067200002	3/8	12	53	30.5	20	10
0067200003	1/2	15	56	30.5	24	10

674

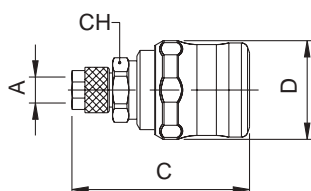
ENCHUFE TUBO - COMPRESSION SOCKET

Código Code	A	B	C	D	CH	Conf. Pack.
0067400001	6/4	-	54.5	30.5	18	10
0067400002	8/6	-	54	30.5	18	10
0067400005	10/6.5	-	57	30.5	18	10
0067400003	10/8	-	56	30.5	18	10
0067400006	12/8	-	57.5	30.5	18	10
0067400004	12/10	-	56.5	30.5	18	10

675

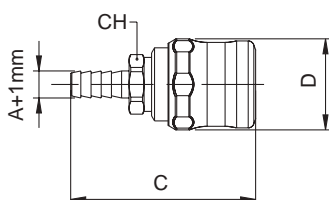
ENCHUFE ESPIGA - SOCKET WITH REST FOR RUBBER HOSE

Código Code	A	B	C	D	CH	Conf. Pack.
0067500001	6	-	61.5	30.5	18	10
0067500002	8	-	61.5	30.5	18	10
0067500003	10	-	61.5	30.5	18	10
0067500004	12	-	61.5	30.5	18	10

271AC

ADAPTADOR EN AVP MACHO - AVP MALE PLUG

ACERO
STEEL

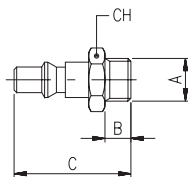

Código Code	A	B	C	D	CH	Conf. Pack.
271AC005103ZI	1/4	8	36	-	17	25
271AC005104ZI	3/8	9	37	-	19	25
271AC005105ZI	1/2	10	38.5	-	24	25

272AC

ADAPTADOR EN AVP HEMBRA - AVP FEMALE PLUG

ACERO
STEEL

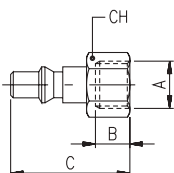

Código Code	A	B	C	D	CH	Conf. Pack.
272AC005103ZI	1/4	11	36	-	17	25
272AC005104ZI	3/8	11.5	36.5	-	19	25
272AC005105ZI	1/2	14	39	-	24	25

275AC

ADAPTADOR EN AVP ESPIGA - AVP PLUG WITH REST FOR RUBBER HOSE

ACERO
STEEL

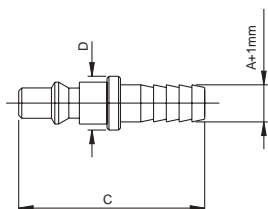

Código Code	A	B	C	D	CH	Conf. Pack.
275AC0051X4ZI	6	-	42.5	11	-	25
275AC0051X7ZI	8	-	42.5	11	-	25
275AC0051X9ZI	10	-	45.5	14	-	25
275AC0051Y1ZI	12	-	45.5	16	-	25

628

PROTECCIÓN ENCHUFE EN EPDM - EPDM SOCKET PROTECTION

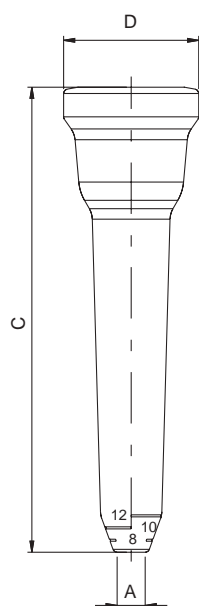

Código Code	A	B	C	D	CH	Conf. Pack.
006280020000	*6 / 8 / 10 / 12	-	105	30.5	-	10

*Cortar la protección en función de la escritura que indica el diámetro externo del tubo utilizado.

Cut the protection on external tube diameter sign.

Aplicación artículo 628 / Item 628 Applications

El artículo 628 es particularmente indicado para los enchufes espiga y para los enchufes tubo.

Artículos con conexión para tubo:

624 - 654 - 664 - 674.

Articoli con conexión espiga:

625 - 655 - 665 - 675.

628 Item is particularly indicated for Socket with rest for rubber tube and compression socket.

Items with compression socket:

624 - 654 - 664 - 674.

Items with rest for rubber tube:

625 - 655 - 665 - 675.

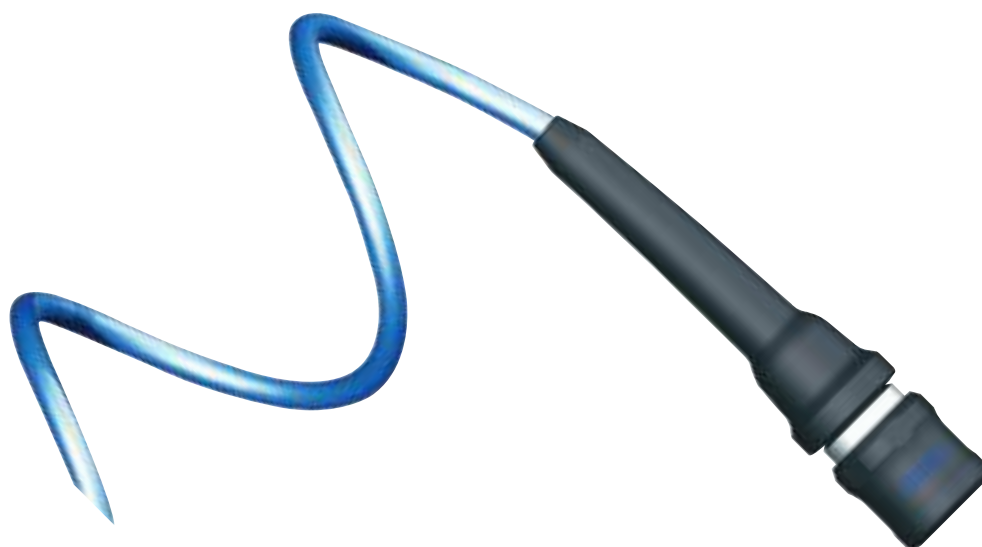



Serie
410-510 DN8
420-520 DN12

**ENCHUFES RÁPIDOS
PARA REFRIGERACIÓN DE MOLDES.**

*QUICK COUPLINGS
FOR MOLDING COOLING.*

410-510 DN8 / 420-520 DN12

La estructura particular de la línea ofrece dimensiones reducidas y consiente la conexión con una sola mano.
 The particular structure that assures reduced size and allows coupling using a single hand.



Características Técnicas / Technical Characteristics

PERFIL FRANCÉS
DN8 & DN12

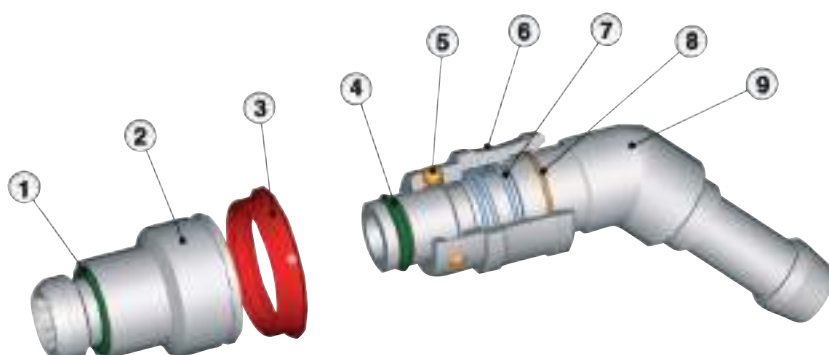

Materiales y Componentes / Component Parts and Materials

- | | |
|------------------------------|------------------------------|
| 1 Junta tórica en FKM | 1 FKM O-Ring seal |
| 2 Enchufe en latón niquelado | 2 Nickel-plated brass socket |
| 3 Anillo en PA66 | 3 PA66 ring |
| 4 Junta tórica en FKM | 4 FKM O-Ring seal |
| 5 Esfera en acero AISI 420 | 5 Steel AISI 420 ball |
| 6 Tuerca en latón niquelado | 6 Nickel-plated brass sleeve |
| 7 Muelle en acero AISI 302 | 7 Steel AISI 302 spring |
| 8 Seeger en bronce | 8 Bronze seeger |
| 9 Cuerpo en latón niquelado | 9 Nickel-plated brass body |

Temperaturas y presiones:

Presión y temperaturas vienen determinadas según el tipo de tubo empleado, por lo tanto estos valores se definen en base a las características del tubo mismo.

Los valores se refieren exclusivamente a los componentes de nuestra producción.

Temperature and pressures:

The working pressures and working temperatures depend on the type of tube used; therefore the values must be determined in accordance with the tube's features. The following values apply only to our products.

Presiones / Pressures

Presión máxima / Maximum pressure: **15 bar (1.5 MPa)**

Temperaturas / Temperatures

Temperatura mínima / Minimum temperature: **-15 °C**
 Temperatura máxima / Maximum temperature: **+110 °C**

Roscas / Threads

Gas cilíndrica conforme ISO 228

Parallel gas in conformity with ISO 228.

*NB: CON ANILLO DE IDENTIFICACIÓN ART. 513 - 523
 SIN ANILLO DE IDENTIFICACIÓN +200°C

*NB: WITH IDENTIFICATION RING ART. 513 - 523
 WITHOUT IDENTIFICATION RING: +200°C

Tubos de conexión / Connection Tubes

Tubos en material plástico, lineal y espiral.

Tubo de goma.

Flexible tubes in plastic and rubber.

Fluidos compatibles / Fluids

Agua, agua refrigerada, aceite.

Water, cooling water, oil.

410-510 SERIES

DN 8 mm

412

ADAPTADOR HEMBRA - FEMALE PLUG

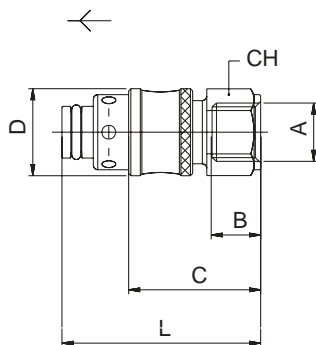

Código Code	A	B	C	D	L	CH	Conf. Pack.
004120001	1/4	11	30	20	47	17	10

415

ADAPTADOR CON PORTAGOMA RECTO - STRAIGHT PLUG WITH REST FOR RUBBER HOSE

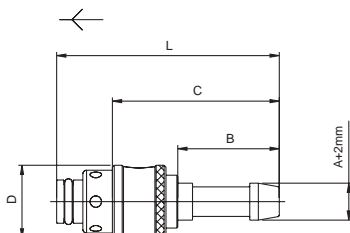

Código Code	A	B	C	D	L	Conf. Pack.
004150001	8	27.5	45	20	62.5	10
004150002	10	27.5	45	20	62.5	10
004150003	12	33	50.5	20	68	10

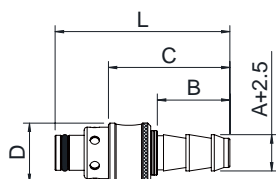

Código Code	A	B	C	D	L	Conf. Pack.
004150004	3/8	24	48	20	60	10
004150005	1/2	28	54.5	20	66	10

416

ADAPTADOR CON PORTAGOMA A 135° - PLUG WITH REST FOR RUBBER HOSE TO 135°

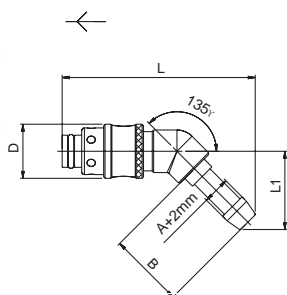

Código Code	A	B	D	L	L1	Conf. Pack.
004160001	8	27.5	20	72.5	28.5	25
004160002	10	27.5	20	73	29	25
004160003	12	33	20	77.5	33.5	25

418

ADAPTADOR CON PORTAGOMA A 90° - PLUG WITH REST FOR RUBBER HOSE TO 90°

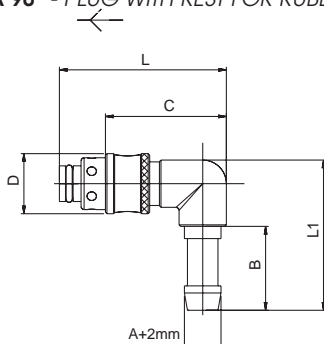

Código Code	A	B	C	D	L	L1	Conf. Pack.
004180001	8	27.5	39.5	20	57	49	25
004180002	10	27.5	39.5	20	57	49	25
004180003	12	33	39.5	20	57	55	25

511

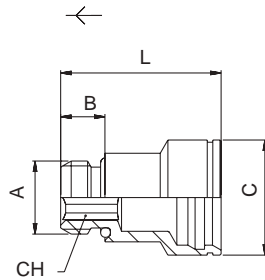
ENCHUFE MACHO - MALE SOCKET

Código Code	A	B	C	L	CH	Conf. Pack.
0051100001	1/8	6	21	27.5	5	10
0051100002	1/4	8	21	29	8	10
0051100003	3/8	9	21	30	10	10

512

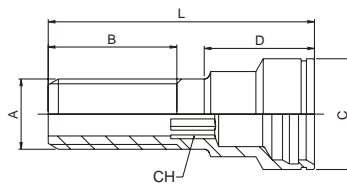
ENCHUFE PROLONGADO MACHO - EXTENDED MALE SOCKET

Código Code	A	B	C	D	L	CH	Conf. Pack.
005120001NUNT	1/8	27	21	21	50	5	10
005120001NVNT	1/8	60	21	21	100	5	10
005120001NWNT	1/8	60	21	21	150	5	10
005120001NXNT	1/8	60	21	21	200	5	10
005120001NYNT	1/4	27	21	20	50	8	10
005120001NZNT	1/4	60	21	20	100	8	10
005120001PANT	1/4	60	21	20	150	8	10
005120001PBNT	1/4	60	21	20	200	8	10
005120001PCNT	3/8	35	21	11	50	10	10
005120001PDNT	3/8	60	21	11	100	10	10
005120001PENT	3/8	60	21	11	150	10	10
005120001PFNT	3/8	60	21	11	200	10	10

514

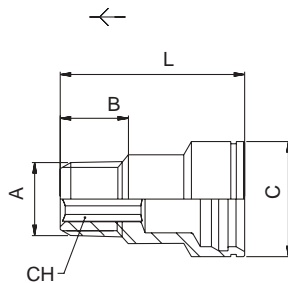
ENCHUFE MACHO CÓNICO PRESELLADO - MALE SOCKET TAPER PRE-COATING

**ROSCA PRESELLADA
PRE-COATING THREAD**

Código Code	A	B	C	L	CH	Conf. Pack.
00514000102TF	1/8	7.5	21	28	5	10
00514000103TF	1/4	11	21	31	8	10
00514000104TF	3/8	11.5	21	31	10	10

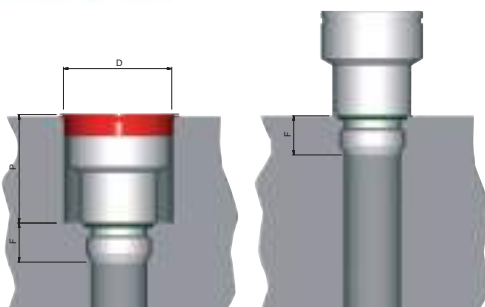
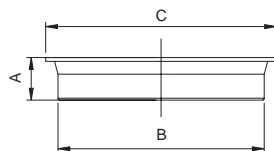
513

ANILLO DE IDENTIFICACIÓN - IDENTIFICATION RING

CÓDIGO CODE	COLOR COLOR	A	B	C	Conf. Pack.
00513RO	ROJO / RED	4.5	22	24.5	25
00513BL	AZUL / BLUE	4.5	22	24.5	25

Dimensiones para la sede enchufe 511
 Seat dimensions for 511 socket

Tamaño / Size	D	P	F
1/8	22	22	6
1/4	22	21.5	8
3/8	22	21.5	9

Dimensiones para la sede enchufe 521
 Seat dimensions for 521 socket

Tamaño / Size	D	P	F
3/8	33	29	9
1/2	33	28.5	10

420-520 SERIES

DN 12 mm

422

ADAPTADOR HEMBRA - FEMALE PLUG

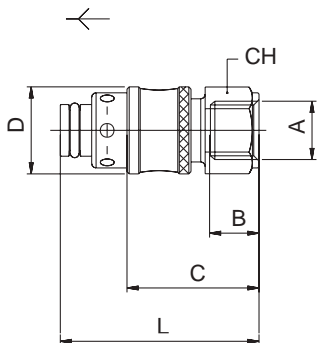

Código Code	A	B	C	D	L	CH	Conf. Pack.
004220001	1/2	15	38.5	28	58	24	10

425

ADAPTADOR CON PORTAGOMA RECTO - STRAIGHT PLUG WITH REST FOR RUBBER HOSE

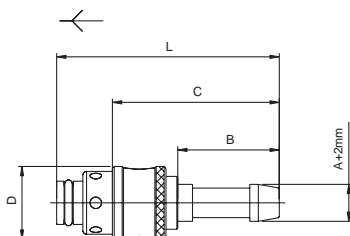

Código Code	A	B	C	D	L	Conf. Pack.
004250001	13	33	55	28	75	10
004250002	16	33	55	28	75	10

521

ENCHUFE MACHO - MALE SOCKET

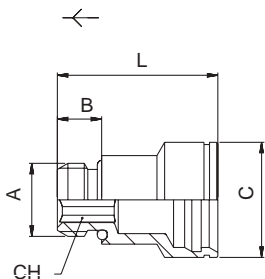

Código Code	A	B	C	L	CH	Conf. Pack.
005210001	3/8	9	32	37.5	10	10
005210002	1/2	10	32	38	12	10

522

ENCHUFE MACHO CÓNICO PRESELLADO - MALE SOCKET TAPER PRE-COATING

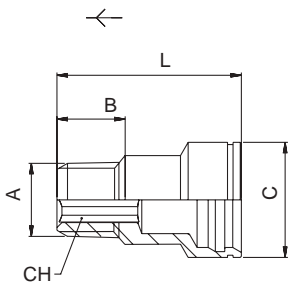

Código Code	A	B	C	L	CH	Conf. Pack.
00522000104TF	3/8	11.5	32	39.5	10	10
00522000105TF	1/2	14	32	41	12	10

ROSCA PRESELLADA
PRE-COATING THREAD

523

ANILLO DE IDENTIFICACIÓN - IDENTIFICATION RING

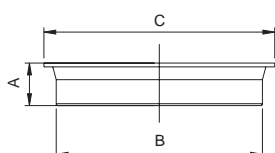

CÓDIGO CODE	COLOR COLOR	A	B	C	Conf. Pack.
00523RO	ROJO / RED	4.5	33	36	25
00523BL	AZUL / BLUE	4.5	33	36	25



Serie
430-530 DN6
440-540 DN9

**ENCHUFES RÁPIDOS
PARA REFRIGERACIÓN DE MOLDES.**

*QUICK COUPLINGS
FOR MOLDING COOLING.*

430-530 DN6 / 440-540 DN9

La geometría de estos enchufes sigue el perfil internacional mayormente generalizado en el campo del enfriamiento de moldes. Está disponible la versión obturada y la no obturada.

The profile of these quick couplings below the international profile of widespread cooling in the mold. Is available not blocked and blocked version.



Características Técnicas / Technical Characteristics

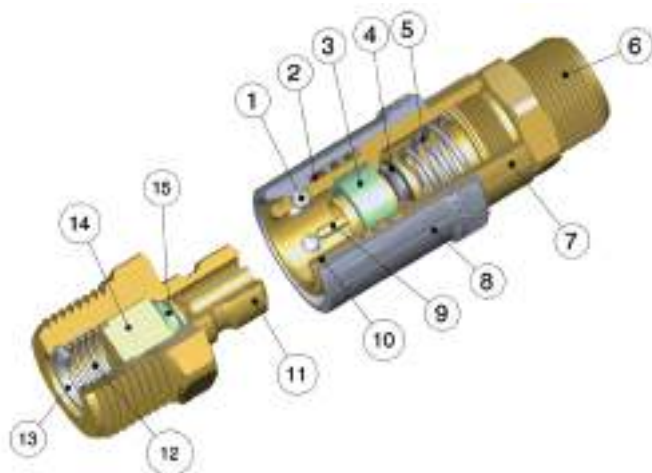

PERFIL INTERNACIONAL INTERNATIONAL PROFILE DN6 E DN9

Versión obturada y no obturada
Blocked and not blocked version

Materiales y Componentes / Component Parts and Materials

- | | |
|---------------------------------------|----------------------------------|
| 1 Esfera en acero AISI 420 | 1 Steel AISI 420 ball |
| 2 Muelle tuerca en acero AISI 302 | 2 Steel AISI 302 ring nut spring |
| 3 Junta en FKM | 3 FKM seal |
| 4 Junta tórica en FKM | 4 FKM O-Ring seal |
| 5 Muelle obturador en acero AISI 302 | 5 Steel AISI 302 shutter spring |
| 6 Conexión terminal en latón | 6 Brass coupling back part |
| 7 Enchufe en latón | 7 Brass socket |
| 8 Tuerca en latón niquelado | 8 Nickel-plated brass sleeve |
| 9 Obturador en latón | 9 Brass shutter |
| 10 Seeger en bronce/latón | 10 Bronze/ Brass seeger |
| 11 Adaptador en latón | 11 Brass plug outline |
| 12 Muelle obturador en acero AISI 302 | 12 Steel AISI 302 shutter spring |
| 13 Obturador en latón | 13 Brass shutter |
| 14 Seeger en acero AISI 302 | 14 Steel AISI 302 seeger |
| 15 Junta tórica en FKM | 15 FKM O-Ring seal |

Temperaturas y presiones:

Presión y temperatura vienen determinadas por el tipo de tubo utilizado, por lo tanto estos valores deben definirse en base a las características del mismo tubo.

Los valores por lo tanto solo se refieren a las componentes que nosotros producimos.

Temperature and pressures:

The working pressures and working temperatures depend on the type of tube used; therefore the values must be determined in accordance with the tube's features. The following values apply only to our products.

Presiones / Pressures

Presión máxima / Maximum pressure: **15 bar (1.5 MPa)**

Roscas / Threads

Gas cilíndrica conforme ISO 228 / Parallel gas in conformity with ISO 228.

Gas cónica conforme ISO 7.1, BS 21, DIN 2999 / Taper gas in conformity with ISO 7.1, BS 21, DIN 2999

Tubos de conexión / Connection Tubes

Tubos en material plástico, lineal o espiral;
tubos en goma.

Flexible tubes in plastic and rubber.

Temperaturas / Temperatures

Temperatura mínima / Minimum temperature: **-15° C**

Temperatura máxima / Maximum temperature: **+200° C**

Fluidos compatibles / Fluids

Agua, agua refrigerada, aceite.

Water, cooling water, oil.

Serie 430-530 DN6

DN 6 mm

431

ENCHUFE MACHO CILÍNDRICO PRESELLADO PARA ADAPTADOR OBTURADO
MALE PARALLEL PRE-COATING SOCKET FOR SHUTTER PLUG

ROSCA PRESELLADA
PRE-COATING THREAD

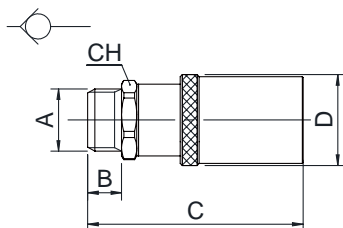

Código Code	A	B	C	D	CH	Conf. Pack.
0043100001	1/4	8	42.5	18.5	14	10

432

ENCHUFE HEMBRA PARA ADAPTADOR OBTURADO - FEMALE SOCKET FOR SHUTTER PLUG

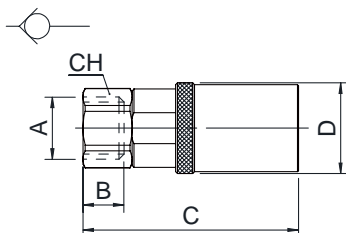

Código Code	A	B	C	D	CH	Conf. Pack.
0043200001	1/4	11	43.5	18.5	14	10

435

ENCHUFE CON PORTAGOMA RECTO PARA ADAPTADOR OBTURADO - STRAIGHT SOCKET WITH REST FOR RUBBER HOSE FOR SHUTTER PLUG

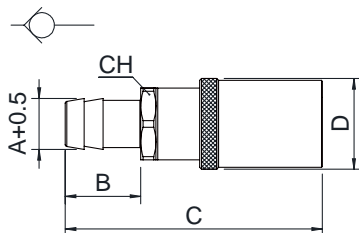

Código Code	A	B	C	D	CH	Conf. Pack.
0043500001	6	20	54.5	18.5	14	10
0043500002	9	20	54.5	18.5	14	10

436

ENCHUFE CON PORTAGOMA 90° PARA ADAPTADOR OBTURADO - STRAIGHT SOCKET WITH 90°REST FOR RUBBER HOSE FOR SHUTTER PLUG

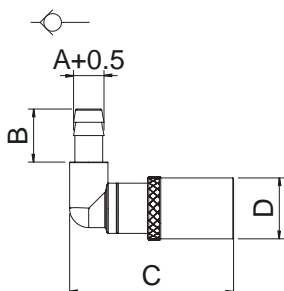

Código Code	A	B	C	D	Conf. Pack.
0043600001	6	20	44	18.5	10
0043600002	9	20	44	18.5	10

431SW

ENCHUFE SIN OBTURADOR MACHO CILÍNDRICO PRESELLADO
 MALE PARALLEL PRE-COATING SOCKET WITHOUT SHUTTER

ROSCA PRESELLADA
PRE-COATING THREAD

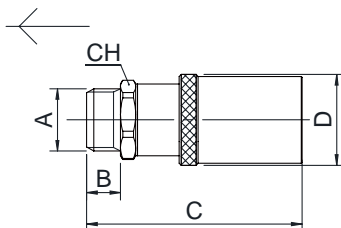

Código Code	A	B	C	D	CH	Conf. Pack.
431SW00001	1/4	8	42.5	18.5	14	10

432SW

ENCHUFE SIN OBTURADOR HEMBRA - FEMALE SOCKET WITHOUT SHUTTER

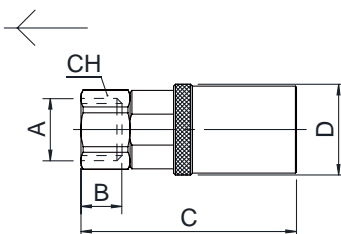

Código Code	A	B	C	D	CH	Conf. Pack.
432SW00001	1/4	11	43.5	18.5	14	10

435SW

ENCHUFE SIN OBTURADOR CON PORTAGOMA - STRAIGHT SOCKET WITH REST FOR RUBBER HOSE WITHOUT SHUTTER

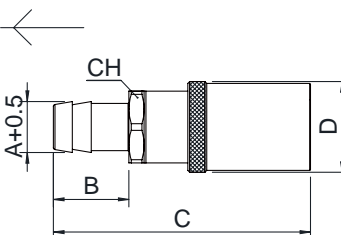

Código Code	A	B	C	D	CH Pack.	Conf.
435SW00001	6	20	54.5	18.5	14	10
435SW00002	9	20	54.5	18.5	14	10

436SW

ENCHUFE SIN OBTURADOR CON PORTAGOMA 90° - STRAIGHT SOCKET WITH 90°REST FOR RUBBER HOSE WITHOUT SHUTTER

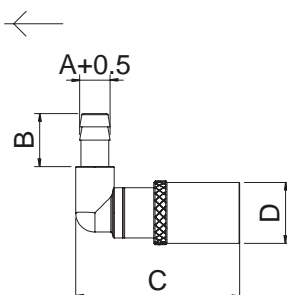

Código Code	A	B	C	D	Conf. Pack.
436SW00001	6	20	44	18.5	10
436SW00002	9	20	44	18.5	10

531

ADAPTADOR MACHO CÓNICO PRESELLADO - MALE PRE-COATING PLUG (TAPER)

ROSCA PRESELLADA
PRE-COATING THREAD

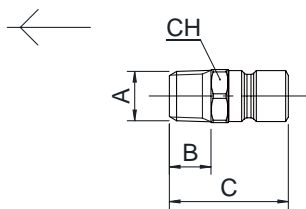

Código Code	A	B	C	CH	Conf. Pack.
0053100001	1/8	7.5	22	13	10
0053100002	1/4	11	26.5	14	10
0053100003	3/8	11.5	27	17	10

532

ADAPTADOR HEMBRA - FEMALE PLUG

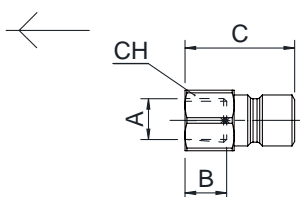

Código Code	A	B	C	CH	Conf. Pack.
0053200010200	1/8	7.5	20	13	10
0053200010300	1/4	11	23.5	16	10
0053200010400	3/8	11.5	24	19	10

534

ADAPTADOR OBTURADO MACHO CÓNICO PRESELLADO - MALE PRE-COATING SHUTTER PLUG (TAPER)

ROSCA PRESELLADA
PRE-COATING THREAD

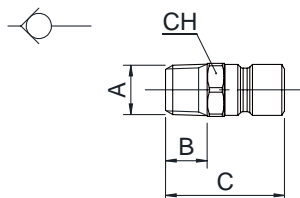

Código Code	A	B	C	CH	Conf. Pack.
0053400001	1/4	11	26.5	14	10
0053400002	3/8	11.5	27	17	10

535

ADAPTADOR CON PORTAGOMA - STRAIGHT PLUG WITH REST FOR RUBBER HOSE

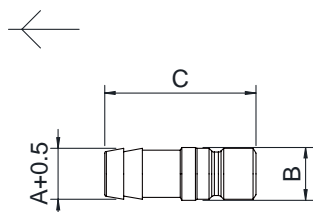

Código Code	A	B	C	Conf. Pack.
005350001X800	9	10	34.5	10

Serie 440-540 DN9

9 mm

441

ENCHUFE MACHO CILÍNDRICO PRESELLADO PARA ADAPTADOR OBTURADO
MALE PARALLEL PRE-COATING SOCKET FOR SHUTTER PLUG

ROSCA PRESELLADA
PRE-COATING THREAD

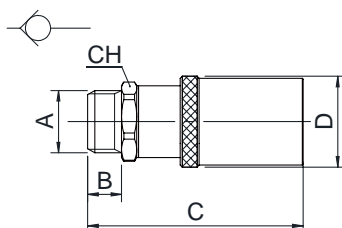

Código Code	A	B	C	D	CH	Conf. Pack.
0044100001	3/8	9	57	24	19	10

442

ENCHUFE HEMBRA PARA ADAPTADOR OBTURADO - FEMALE SOCKET FOR SHUTTER PLUG

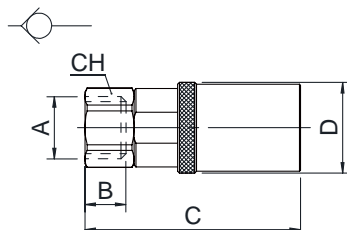

Código Code	A	B	C	D	CH	Conf. Pack.
0044200001	1/4	11	57	24	19	10

445

ENCHUFE CON PORTAGOMA RECTO PARA ADAPTADOR OBTURADO - STRAIGHT SOCKET WITH REST FOR RUBBER HOSE FOR SHUTTER PLUG

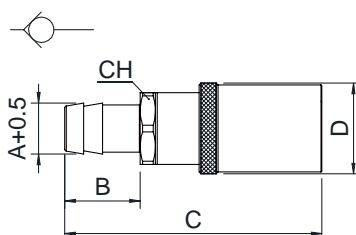

Código Code	A	B	C	D	CH	Conf. Pack.
0044500001	11	20	68	24	19	10
0044500002	13	20	68	24	19	10

446

ENCHUFE CON PORTAGOMA 90° PARA ADAPTADOR OBTURADO - STRAIGHT SOCKET WITH 90° REST FOR RUBBER HOSE FOR SHUTTER PLUG

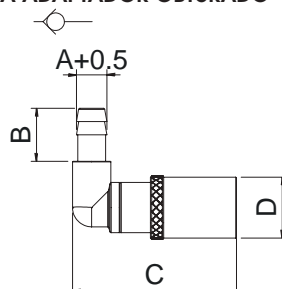

Código Code	A	B	C	D	Conf. Pack.
0044600001	11	20	62	24	10
0044600002	13	20	62	24	10

441SW

ENCHUFE SIN OBTURADOR MACHO CILÍNDRICO PRESELLADO
 MALE PARALLEL PRE-COATING SOCKET WITHOUT SHUTTER

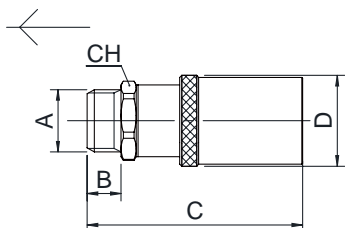

Código Code	A	B	C	D	CH	Conf. Pack.
441SW00001	3/8	9	57	24	19	10

442SW

ENCHUFE SIN OBTURADOR HEMBRA - FEMALE SOCKET WITHOUT SHUTTER

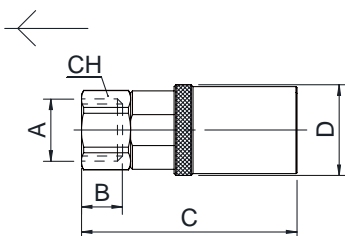

Código Code	A	B	C	D	CH	Conf. Pack.
442SW00001	1/4	11	57	24	19	10

445SW

ENCHUFE SIN OBTURADOR CON PORTAGOMA - STRAIGHT SOCKET WITH REST FOR RUBBER HOSE WITHOUT SHUTTER

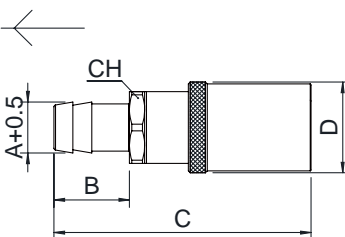

Código Code	A	B	C	D	CH	Conf. Pack.
445SW00001	11	20	68	24	19	10
445SW00002	13	20	68	24	19	10

446SW

ENCHUFE SIN OBTURADOR CON PORTAGOMA 90° - STRAIGHT SOCKET WITH 90°REST FOR RUBBER HOSE WITHOUT SHUTTER

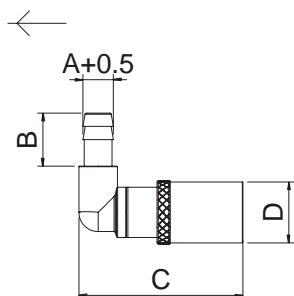

Código Code	A	B	C	D	Conf. Pack.
446SW00001	11	20	62	24	10
446SW00002	13	20	62	24	10

541

ADAPTADOR MACHO CÓNICO PRESELLADO - MALE PRE-COATING PLUG (TAPER)

ROSCA PRESELLADA
PRE-COATING THREAD

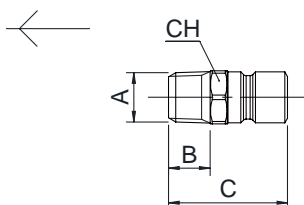

Código Code	A	B	C	CH	Conf. Pack.
0054100001	1/4	11	31.5	14	10
0054100002	3/8	11.5	32.5	17	10
0054100003	1/2	14	36.5	22	10

542

ADAPTADOR HEMBRA - FEMALE PLUG

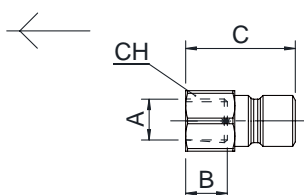

Código Code	A	B	C	CH	Conf. Pack.
0054200010300	1/4	11	29	16	10
0054200010400	3/8	11.5	29.5	19	10
0054200010500	1/2	15	33	24	10

544

ADAPTADOR OBTURADO MACHO CÓNICO PRESELLADO - MALE PRE-COATING SHUTTER PLUG (TAPER)

ROSCA PRESELLADA
PRE-COATING THREAD

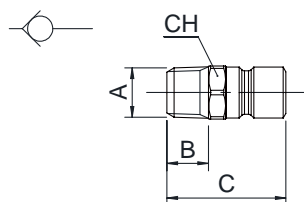

Código Code	A	B	C	CH	Conf. Pack.
0054400001	3/8	11.5	32.5	17	10
0054400002	1/2	14	36.5	22	10

545

ADAPTADOR CON PORTAGOMA - STRAIGHT PLUG WITH REST FOR RUBBER HOSE

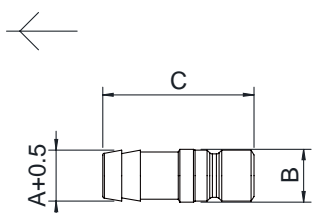

Código Code	A	B	C	Conf. Pack.
005450001Y200	13	14	40	10



Serie 300

PISTOLAS SOPLADORAS
BLOW GUNS

Características Técnicas / Technical Characteristics

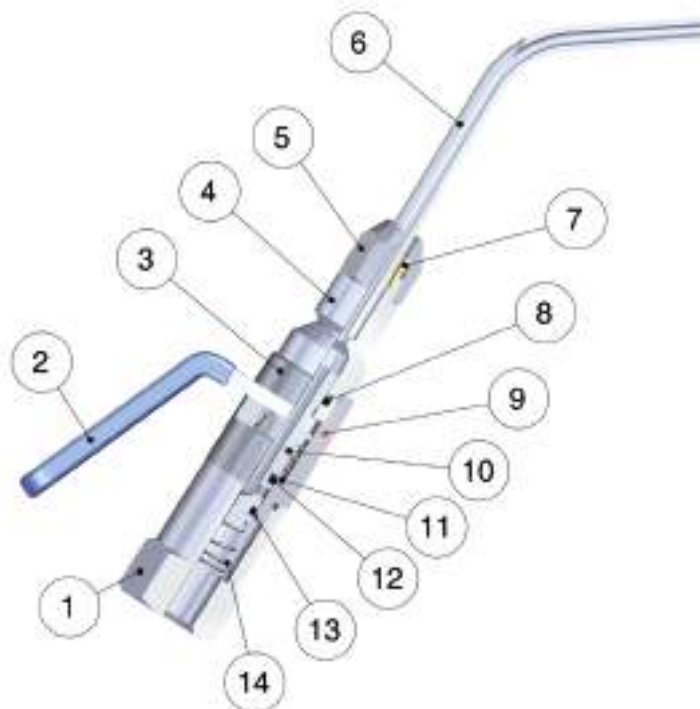

Especificaciones de Material / Specifications

1 Conexión terminal en latón niquelado	1 Nickel-plated Brass Back Connection
2 Maneta en latón niquelado plastificada	2 Nickel-plated Brass Handferro Plastified
3 Cuerpo central en latón niquelado	3 Nickel-plated Brass Central Body
4 Cuerpo anterior en latón niquelado	4 Nickel-plated Brass Front Body
5 Tuerca de bloqueo en latón niquelado	5 Nickel-plated Brass Locking nut
6 Boquilla de soplado en acero A10 niquelado	6 Nickel-plated inox Nozzle
7 Bicono sujeción tubo en latón	7 Brass Clamping olive
8 Junta tórica en NBR 70	8 NBR 70 O-RING Seals
9 Perno en acero	9 Steel Pin
10 Pistón en latón niquelado	10 Nickel-plated Brass Plunger
11 Muelle empuje pistón en acero AISI 302	11 Stell AISI 302 Plunger thrust spring
12 Junta tórica en NBR 70	12 NBR 70 O-RING Seals
13 Junta tórica en NBR 70	13 NBR 70 O-RING Seals
14 Muelle posterior pistón en acero AISI 302	14 Steel AISI 302 Plunger back Spring

Presiones / Pressures

Presión mínima / Minimum pressure: **-0.99 bar (-0.099 MPa)**
 Presión máxima / Maximum pressure: **10 bar (1 MPa)**

Fluidos compatibles / Fluids

Aire comprimido / Compressed air.

Roscas / Threads

Gas cilíndrica conforme ISO 228 Classe A
 Parallel gas in conformity with ISO 228 Class A.

Métrica conforme ISO R/262
 Metric in conformity with ISO R/262.

321

PISTOLA DE SOPLADO - HEMBRA - BLOW GUN FEMALE CONNECTION

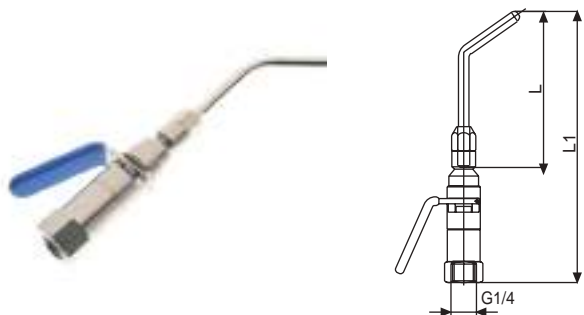

Código Code	L	L1	Conf. Pack.
0032100001	90	157	10
0032100002	200	267	1
0032100003	290	357	1

322

PISTOLA DE SOPLADO CON PANTALLA DE AIRE PROTECTORA HEMBRA
BLOW GUN WITH PROTECTIVE AIR-SCREEN FEMALE CONNECTION

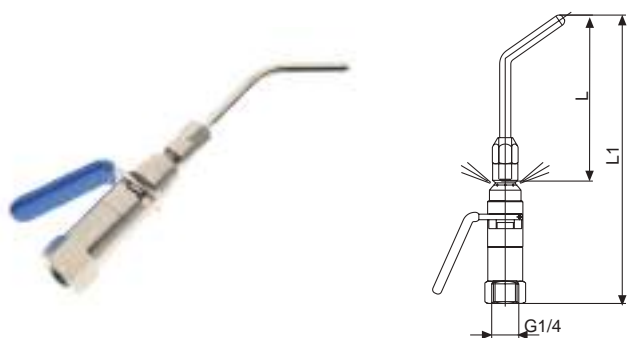

Código Code	L	L1	Conf. Pack.
0032200001	90	157	10
0032200002	200	267	1
0032200003	290	357	1

325

PISTOLA DE SOPLADO - CONEXIÓN TUBO CON MUELLE - BLOW GUN - PUSH-ON CONNECTION WITH SPRING



Código Code	L	A	L1	Conf. Pack.
0032500001	90	- 8/6	250.5	1
0032500002	90	- 10/8	251.5	1
0032500003	200	- 8/6	360.5	1
0032500004	200	- 10/8	361.5	1
0032500005	290	- 8/6	450.5	1
0032500006	290	- 10/8	451.5	1

326

PISTOLA DE SOPLADO CON PANTALLA DE AIRE PROTECTORA PARA CONEXIÓN TUBO CON MUELLE
BLOW GUN WITH PROTECTIVE AIR SCREEN PUSH-ON CONNECTION WITH SPRING



Código Code	L	A	L1	Conf. Pack.
0032600001	90	- 8/6	250.5	1
0032600002	90	- 10/8	251.5	1
0032600003	200	- 8/6	360.5	1
0032600004	200	- 10/8	361.5	1
0032600005	290	- 8/6	450.5	1
0032600006	290	- 10/8	451.5	1

310

BOQUILLA RECTA (RECAMBIO) - STRAIGHT NOZZLE (SPARE PART)

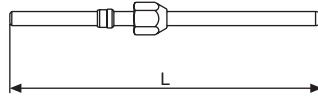

Código Code	L	Conf. Pack.
0031000001	100	1
0031000002	210	1
0031000003	300	1

CADA BOQUILLA ESTÁ COMPLETA DE TUERCA Y BICONO.
EVERY NOZZLE IS SUPPLIED WITH NUT AND OLIVE.

311

BOQUILLA ANGULADA (RECAMBIO) - ELBOW NOZZLE (SPARE PART)

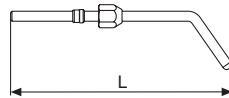

Código Code	L	Conf. Pack.
0031100001	90	1
0031100002	200	1
0031100003	290	1

CADA BOQUILLA ESTÁ COMPLETA DE TUERCA Y BICONO.
EVERY NOZZLE IS SUPPLIED WITH NUT AND OLIVE.

312

BOQUILLA EFECTO VENTURI (RECAMBIO) - VENTURI'S EFFECT NOZZLE (SPARE PART)

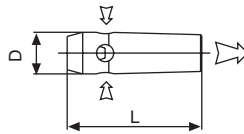

	D	L	Conf. Pack.
	17	55	1

340

PISTOLA DE SOPLADO Ø6MM HEMBRA EN TECNOPOLÍMERO - BLOWGUN WITH Ø6MM BENT PIPE FEMALE POLYMER THREAD

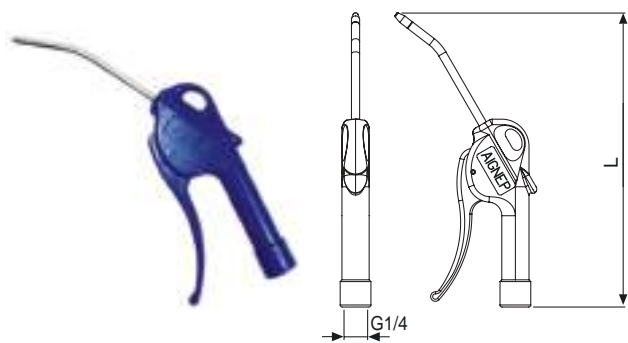

Código Code	L	Conf. Pack.
003400001	215	1

341

PISTOLA DE SOPLADO Ø6MM HEMBRA CON CASQUILLO METÁLICO - BLOWGUN WITH Ø6MM BENT PIPE WITH METAL BUSHING



Código Code	L	Conf. Pack.
003410001	217	1

342

PISTOLA DE SOPLADO Ø6MM INOX CON TUBO CURVADO SUPER SILENCIOSA - BLOWGUN WITH Ø6MM STAINLESS BENT PIPE SUPER SILENT

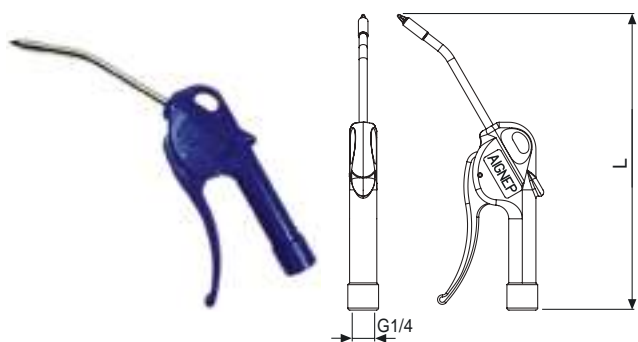

Código Code	L	Conf. Pack.
003420001	215	1

343

PISTOLA DE SOPLADO DE SEGURIDAD A 3,5 BAR CON TUBO CURVADO DE Ø8MM - BLOWGUN WITH Ø8MM BENT PIPE - 3,5 BAR UNBLOCKABLE

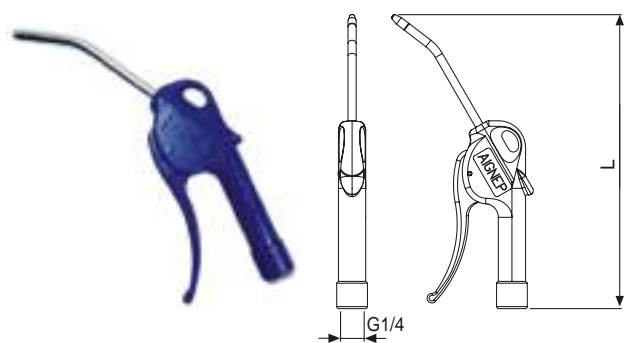

Código Code	L	Conf. Pack.
003430001	217	1



COMPRESSION FITTINGS

9000
10000
13000

SERIE 9000 - RACORDAJE A COMPRESIÓN
COMPRESSION FITTINGS

SERIE 10000 - RACORDAJE UNIVERSAL A BICONO
UNIVERSAL DOUBLE CONE FITTINGS

SERIE 13000 - RACORDAJE UNIVERSAL
UNIVERSAL FITTINGS

Instrucciones de Montaje/ Assembling Instruction

Serie 9000 - 10000 - 13000

Para garantizar las mejores prestaciones de nuestros racores, indicamos una secuencia de operaciones para seguir durante el montaje, que contribuirán a eliminar pérdidas de tiempo, e incorrectas aplicaciones del producto.

To ensure the best function of our fittings, please follow the under mentioned instructions, in order to avoid waste of time and bad applications of the product.

1

Cortar el tubo a 90° eliminando rebabas internas y externas.

Cut the tube at 90° and remove internal and external burrs.

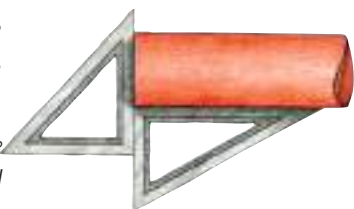
3

Apretar manualmente la tuerca hasta obtener cierta resistencia del bicono.

Screw the nut onto the fitting by hand until hand-tight.

5

Apretar la tuerca (1 giro y 1/4 o 1/2) indicando si es necesario un punto de referencia.

Tighten the nut with the spanner one and a quarter turns, marking reference points, if necessary.

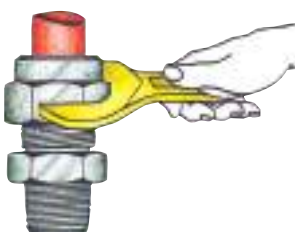
6

Para garantizar que el bicono haya incidido el tubo, aflojar la tuerca y controlar la uniformidad del apriete.

To ensure that the olive has gripped the tube correctly. Unscrew the nut and make sure that the groove made by the olive is even.

2

Poner aceite en la rosca de la tuerca y del cuerpo del racor incluyendo el bicono. Seguidamente enfilar en el tubo la tuerca y el bicono, asegurando que este último tenga la parte cortante hacia el racor.

Lightly oil the tube nut, olive and fitting thread. Slide the nut and olive onto the tube ensuring that the sharp side of the olive is facing the fitting.

4

Verificar la completa adhesión del tubo al cuerpo, forzándolo hacia el interno del racor y seguidamente con la llave, bloquear el tubo.

Ensure the tube is pushed fully home into the fitting before tightening the nut with the correct spanner.

7

Apretar la tuerca cerca de 1/4 de giro. Otra advertencia para un buen montaje: En el caso de tubos curvados, en proximidad del racor, el tubo deberá tener una distancia rectilínea por lo menos del doble de la altura de la tuerca.

Tighten the nut again with an extra quarter turn. Additional information to ensure correct assembly. Where fitting to curved tubes ensure that the section entering the fitting is straight for a minimum length of twice the nut height.

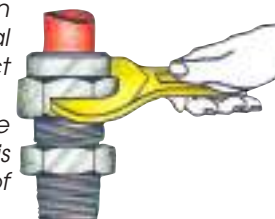



Serie 9000

RACORDAJE A BICONO
COMPRESSION FITTINGS

Características Técnicas / Technical Characteristics

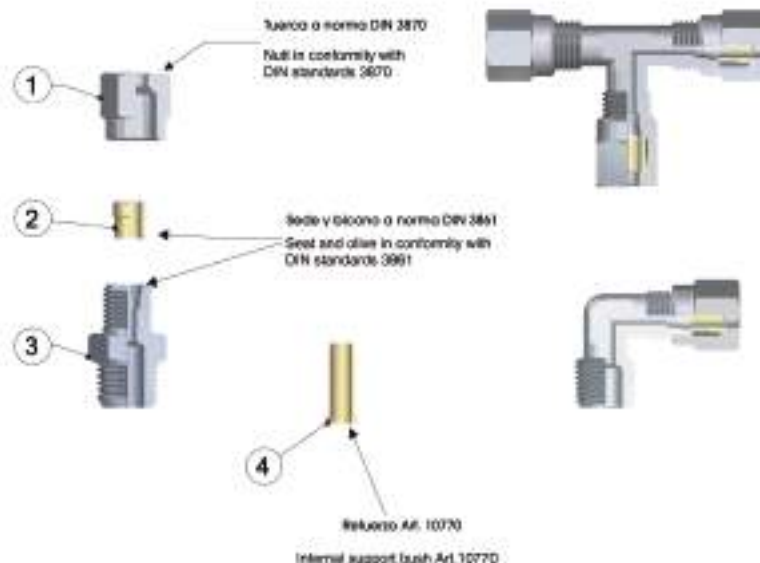

Materiales y Componentes / Component Parts and Materials

- | | |
|-----------------------------|----------------------------|
| 1 Tuerca en Latón niquelado | 1 Nickel-plated Brass Nut |
| 2 Bicono en Latón Recocido | 2 Annealed Brass Olive |
| 3 Cuerpo en Latón niquelado | 3 Nickel-plated Brass Body |
| 4 Refuerzo | 4 Internal support bush |

Presiones y Temperaturas / Pressures and Temperatures

Presión y temperatura vienen determinadas según el tipo de tubo empleado, por lo tanto estos valores se definen en base a las características del mismo tubo. Representamos a continuación los valores de las presiones máximas aconsejadas para la utilización de los racores con tubo de cobre espesor 1 mm a 20° C.

The working pressures and working temperatures depend on which type of tube is used, for this reason, the values must be determined in accordance with the tube's features.

Hereunder, we specify the values of the maximum pressure advised for the fittings at a temperature of 20° C connected with copper tube, which has a thickness of 1 mm.

Los valores de las presiones aconsejadas, representadas en la tabla, han sido obtenidas de valores de prueba adoptando un coeficiente de seguridad 4.

Están disponibles los certificados de las pruebas realizadas en distintos laboratorios especializados.

The values of working pressures advised, specified in table have been obtained from the test values using a Safety Factor 4. It is available the test report made by the external laboratory test.

Tamaño Size	Presión máxima aconsejada Maximum Pressure Advised
Ø 4LL	130 kg/cm ² . - 128.6 Bar
Ø 6LL	180 kg/cm ² . - 178.1 Bar
Ø 8LL	150 kg/cm ² . - 148.4 Bar
Ø 10L	115 kg/cm ² . - 113.8 Bar
Ø 12L	75 kg/cm ² . - 74.2 Bar
Ø 14S	70 kg/cm ² . - 69.3 Bar
Ø 16S	70 Kg/cm ² . - 69.3 Bar
Ø 18L	65 Kg/cm ² . - 64.3 Bar

Roscas / Threads

Gas cónica conforme ISO 7.1, BS 21, DIN 2999 / Tapered gas in conformity with ISO7.1, BS 21, DIN 2999.

Gas cilíndrica conforme ISO 228 / Parallel gas in conformity with ISO 228.

Métrica conforme ISO R/262 / Metric in conformity with ISO R/262.

Tubos de conexión / Connection Tubes

Tubos en cobre, hierro, acero, aluminio, latón, etc...

Con el correspondiente refuerzo interno (art. 10770), pueden utilizarse también con tubo en PA11, PA 6, etc...

Tubes made in copper, steel, iron, aluminium, brass, etc.

With an inside support bush (art. 10770), can be used also for plastic material such as PA11, PA6, etc.

Fluidos compatibles / Fluids

Agua, aceite, aire comprimido, fluidos en general para instalaciones hidráulicas, oleodinámicas, hidroneumáticas, etc..

Water, oils, compressed air, fluids in general for the hydraulic, pneumatic and oildynamic plants etc.

9200

RACOR A T INTERMEDIO - TEE CONNECTOR



Código Code	Tubo Tube	L1	L2	CH	Conf. Pack.
092000001	4	46	21	8	25
092000002	6	48	22.5	9	25
092000003	8	53	25	12	25
092000004	10	65	31.5	13	25
092000005	12	68	33	14	25
092000006	14	76	42	17	10
092000007	15	78	38	17	10
092000008	16	86	42.5	20	10
092000009	18	90	44	22	10

9220

RACOR A T MACHO CENTRAL - TEE MALE ADAPTOR - CENTRE LEG



Código Code	Tubo Tube	A	B	L1	L2	CH	Conf. Pack.
092200001	4	1/8	7.5	45	15	8	50
092200002	6	1/8	7.5	45	16.5	9	25
092200003	6	1/4	11	45	20.5	9	25
092200004	8	1/8	7.5	52	17	12	25
092200005	8	1/4	11	52	20.5	12	25
092200006	8	3/8	11.5	50	24	13	25
092200007	10	1/4	11	64	23.5	13	25
092200008	10	3/8	11.5	64	24	13	25
092200009	12	3/8	11.5	68	25	14	25
092200010	12	1/2	14	68	26.5	14	25
092200011	14	1/2	14	84	30	17	25
092200012	15	1/2	14	76	28	17	25
092200013	16	1/2	14	85	31.5	20	10
092200014	18	1/2	14	88	34	22	10

9230

RACOR A T MACHO LATERAL - TEE MALE ADAPTOR OFF SET LEG



Código Code	Tubo Tube	A	B	L1	L2	CH	Conf. Pack.
092300001	4	1/8	7.5	37.5	21	8	50
092300002	6	1/8	7.5	39.5	22.5	9	25
092300003	6	1/4	11	43	23	9	25
092300004	8	1/8	7.5	43.5	25	12	25
092300005	8	1/4	11	47	25	12	25
092300006	8	3/8	11.5	50	25	13	25
092300007	10	1/4	11	55.5	31	13	25
092300008	10	3/8	11.5	56.5	31.5	13	25
092300009	12	3/8	11.5	59	33	14	25
092300010	12	1/2	11.5	59.5	25	15	25
092300011	14	1/2	14	68	42	17	25
092300012	15	1/2	14	68	38	17	25
092300013	16	1/2	14	74.5	42.5	20	10
092300014	18	1/2	14	79	44	22	10

9260

RACOR A L INTERMEDIO - ELBOW CONNECTOR



Código Code	Tubo Tube	L	CH	Conf. Pack.
092600001	4	21	8	50
092600002	6	22.5	9	50
092600003	8	26.5	12	25
092600004	10	31.5	13	25
092600005	12	34.5	14	25
092600006	14	38	17	25
092600007	15	37.5	17	25
092600008	16	44	19	10
092600009	18	44	22	10

9280

RACOR A L MACHO - ELBOW MALE ADAPTOR

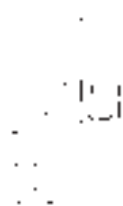

Código Code	Tubo Tube	A	B	L1	L2	CH	Conf. Pack.
0928000001	4	1/8	7.5	22	15	8	50
0928000002	6	1/8	7.5	23.5	17	9	50
0928000003	6	1/4	11	24	19.5	9	50
0928000004	8	1/8	7.5	26.5	18	12	50
0928000005	8	1/4	11	26.5	21.5	11	25
0928000006	8	3/8	11.5	29.5	24.5	13	25
0928000007	10	1/4	11	33	23.5	13	25
0928000008	10	3/8	11.5	33	24.5	13	25
0928000009	12	3/8	11.5	34.5	25	14	25
0928000010	12	1/2	14	34.5	28	15	25
0928000011	14	1/2	14	38.5	30	17	25
0928000012	15	1/2	14	37	29	17	25
0928000013	16	1/2	14	43	31.5	19	10
0928000014	18	1/2	14	44	33.5	22	10

9460

RACOR RECTO INTERMEDIO - STRAIGHT CONNECTOR

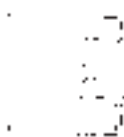

Código Code	Tubo Tube	L	CH	Conf. Pack.
0946000001	4	36	9	50
0946000002	6	39	12	50
0946000003	8	39	12	50
0946000004	10	48	17	25
0946000005	12	49	19	25
0946000006	14	53	24	25
0946000007	15	50	24	25
0946000008	16	53.5	27	10
0946000009	18	53	27	10

9480

RACOR RECTO MACHO - STRAIGHT MALE ADAPTOR



Código Code	Tubo Tube	A	B	L	CH	Conf. Pack.
0948000001	4	1/8	7.5	27.5	11	50
0948000002	6	1/8	7.5	28	11	50
0948000003	6	1/4	11	31.5	14	50
0948000004	8	1/8	7.5	30	12	50
0948000005	8	1/4	11	33.5	14	25
0948000006	8	3/8	11.5	35	17	25
0948000007	10	1/4	11	38	16	25
0948000008	10	3/8	11.5	38.5	17	25
0948000009	12	3/8	11.5	38.5	18	25
0948000010	12	1/2	14	41.5	21	25
0948000011	14	1/2	14	44	22	25
0948000012	15	1/2	14	43.5	22	25
0948000013	16	1/2	14	45	24	10
0948000014	18	1/2	14	45	26	10

9500

RACOR RECTO HEMBRA - STRAIGHT FEMALE ADAPTOR



Código Code	Tubo Tube	A	B	L	CH	Conf. Pack.
095000001	4	1/8	8.5	26.5	14	50
095000002	6	1/8	8.5	26.5	14	50
095000003	6	1/4	11	30	17	50
095000004	8	1/8	8.5	27.5	14	50
095000005	8	1/4	11	31	17	50
095000006	8	3/8	11.5	32.5	20	25
095000007	10	1/4	11	32.5	17	25
095000008	10	3/8	11.5	34.5	20	25
095000009	12	3/8	11.5	34.5	20	25
095000010	12	1/2	15	39	24	25
095000011	14	1/2	15	40	24	25
095000012	15	1/2	15	39.5	24	25
095000013	16	1/2	15	41	24	10
095000014	18	1/2	15	41	26	10

9550

RACOR A L ORIENTABLE - SINGLE BANJO BODY

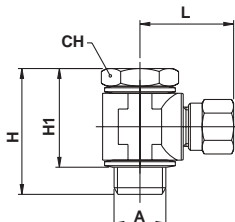

Código Code	Tubo Tube	A	L	H	H1	CH	Conf. Pack.
095500001	4	1/8	23	31	24	14	25
095500002	6	1/8	24	31	24	14	25
095500003	6	1/4	27.5	32	24.5	17	25
095500004	8	1/8	27.5	31	24	14	25
095500005	8	1/4	27.5	32	24.5	17	25
095500006	8	3/8	30	37.5	24.5	19	25
095500007	10	1/4	33	32	24.5	17	25
095500008	10	3/8	33.5	36	27.5	19	25
095500009	12	3/8	36	46	38	22	25

9680

TUERCA - NUT



Código Code	Tubo Tube	H	CH	M	Conf. Pack.
096800001X1NB	4 LL	11	10	M8x1	50
096800001X4NB	6 LL	11.5	12	M10x1	50
096800001X7NB	8 LL	12	14	M12x1	50
096800001X9NB	10 L	15.5	19	M16x1.5	50
096800001Y1NB	12 L	15.5	22	M18x1.5	50
096800001Y3NB	14 S	18.5	27	M22x1.5	25
096800001Y4NB	15 L	17	27	M22x1.5	25
096800001Y5NB	16 S	18.5	30	M24x1.5	25
096800001Y7NB	18 L	18	32	M26x1.5	25

9740

BICONO - OLIVE



Código Code	Tubo Tube	H	Conf. Pack.
097400002X100	4 LL	6	50
097400002X400	6 LL	7	50
097400002X700	8 LL	7.5	50
097400002X900	10 L	9.5	50
097400002Y100	12 L	9.5	50
097400002Y300	14 S	9.5	25
097400002Y400	15 L	9.5	25
097400002Y500	16 S	9.5	25
097400002Y700	18 L	10	25



Serie 10000

RACORDAJE UNIVERSAL A BICONO
UNIVERSAL DOUBLE CONE FITTINGS

Características Técnicas / Technical Characteristics



Materiales y Componentes / Component Parts and Materials

- | | |
|------------------------------------|-----------------------------------|
| 1 Tuerca en Latón Niquelado | 1 Nickel-plated Brass Nut |
| 2 Bicono en Latón (PTFE a demanda) | 2 Brass Olive (If requested PTFE) |
| 3 Cuerpo en Latón Niquelado | 3 Nickel-plated Brass Body |
| 4 Refuerzo | 4 Internal support bush |

Presiones y Temperaturas / Pressures and Temperatures

Presión y temperatura vienen determinadas según el tipo de tubo empleado, por lo tanto estos valores se definen en base a las características del mismo tubo. Representamos a continuación los valores de las presiones máximas aconsejadas para la utilización de los racores con tubo de cobre espesor 1 mm a 20° C.

The working pressures and working temperatures depend on which type of tube is used, for this reason, the values must be determined in accordance with the tube's features. Hereunder, we specify the values of the maximum pressure advised for the fittings at a temperature of 20° C connected with copper tube, which has a thickness of 1 mm.

Los valores de las presiones aconsejadas, representadas en la tabla, han sido obtenidas de valores de prueba adoptando un coeficiente de seguridad 4. Están disponibles los certificados de las pruebas realizadas en distintos laboratorios especializados.

The values of working pressures advised, specified in table have been obtained from the test values using a Safety Factor 4. It is available the test report made by the external laboratory test.

TAMAÑO SIZE	PRESIÓN MÁXIMA ACONSEJADA MAXIMUM PRESSURE ADVISED
ø 4	150 kg/cmq. - 148.4 Bar
ø 6	150 kg/cmq. - 148.4 Bar
ø 8	130 kg/cmq. - 128.6 Bar
ø 10	180 kg/cmq. - 178.1 Bar
ø 12	150 kg/cmq. - 148.4 Bar
ø 14	115 kg/cmq. - 113.3 Bar
ø 16	75 kg/cmq. - 74.2 Bar
ø 18	60 kg/cmq. - 59.4 Bar
ø 22	40 kg/cmq. - 39.6 Bar

Roscas / Threads

Gas cónica conforme ISO 7.1, BS 21, DIN 2999 / Tapered gas in conformity with ISO 7.1, BS 21, DIN 2999.

Gas cilíndrica conforme ISO 228 / Parallel gas in conformity with ISO 228.

Métrica conforme ISO R/262 / Metric in conformity with ISO R/262.

Tubos de conexión / Connection Tubes

Tubos en cobre, hierro, acero, aluminio, latón, etc...

Con el correspondiente refuerzo interno (art.10770), pueden utilizarse también con tubo en PA11, PA6, etc.

Tubes made in copper, steel, iron, aluminium, brass, etc.

With an inside support bush (art. 10770), can be used also for plastic material such as PA11, PA6. etc.

Fluidos compatibles / Fluids

Agua, aceite, aire comprimido, fluidos en general para instalaciones hidráulicas, oleodinámicas, hidroneumáticas, etc...

Water, oils, compressed air, fluids in general for the hydraulic, pneumatic and oildynamic plants etc.

10200

RACOR A T INTERMEDIO - TEE CONNECTOR



Código Code	Tubo Tube	L1	L2	CH	Conf. Pack.
102000001	4	41	20.5	8	25
102000002	6	46	23	9	25
102000003	8	53	26.5	12	25
102000004	10	62	31	13	25
102000005	12	67	33.5	14	25
102000006	14	72	36	18	10
102000007	15	78	39	18	10
102000008	16	78	39	17	10
102000009	18	83	41.5	20	10
102000010	22	86	43	27	10

10220

RACOR A T MACHO CENTRAL - TEE MALE ADAPTOR CENTRE LEG

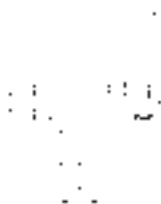

Código Code	Tubo Tube	A	L1	L2	CH	Conf. Pack.
102200001	4	1/8	41	15	8	50
102200002	6	1/8	46	16.5	9	25
102200003	6	1/4	46	20.5	9	25
102200004	8	1/8	53	16.5	12	25
102200005	8	1/4	53	20.5	12	25
102200006	8	3/8	57	23	13	25
102200007	10	1/4	62	22.5	13	25
102200008	10	3/8	62	23.5	13	25
102200009	10	1/2	64	27	14	25
102200010	12	1/4	66	24.5	14	25
102200011	12	3/8	66	25	14	25
102200012	12	1/2	67	26.5	14	25
102200013	14	3/8	75	26	16	10
102200014	14	1/2	78	31	18	10
102200015	15	1/2	80	31	18	10
102200016	16	1/2	79	29	17	10
102200017	18	1/2	84	29.5	20	10
102200018	18	3/4	82	32.5	20	10
102200019	22	3/4	86	34	27	10

10230

RACOR A T MACHO LATERAL - TEE MALE ADAPTOR OFF SET LEG



Código Code	Tubo Tube	A	L1	L2	CH	Conf. Pack.
102300001	4	1/8	35	21	8	50
102300002	6	1/8	39	24	9	25
102300003	6	1/4	43	23	9	25
102300004	8	1/8	43	26	12	25
102300005	8	1/4	46	26	12	25
102300006	8	3/8	49	26	13	25
102300007	10	1/4	55	31	13	25
102300008	10	3/8	54	31	13	25
102300009	12	3/8	58	33	14	25
102300010	12	1/2	59	34	15	25
102300011	14	1/2	67	39	18	25

10240

RACOR A T HEMBRA CENTRAL - TEE FEMALE CENTRE LEG



Código Code	Tubo Tube	A	L1	L2	CH	Conf. Pack.
1024000001	4	1/8	42	18	8	50
1024000002	6	1/8	46.5	19.5	9	25
1024000003	6	1/4	54	24.5	13	25
1024000004	8	1/8	53	19.5	12	25
1024000005	8	1/4	55	24.5	13	25
1024000007	10	1/4	63	24.5	13	25
1024000008	10	3/8	65	26	14	25
1024000009	10	1/2	66	26	15	25
1024000010	12	1/4	66	25.5	14	25
1024000011	12	3/8	66	26	14	25
1024000012	12	1/2	66	26	15	25
1024000013	14	1/2	67	30	18	10
1024000014	15	1/2	77	30	18	10
1024000015	16	1/2	77	28.5	17	10
1024000016	18	1/2	84	28	20	10
1024000017	18	3/4	83	34	20	10

10260

RACOR A L INTERMEDIO - ELBOW CONNECTOR



Código Code	Tubo Tube	L	CH	Conf. Pack.
1026000001	4	20	8	50
1026000002	6	24	9	50
1026000003	8	28	11	25
1026000004	10	32	13	25
1026000005	12	34	14	25
1026000006	14	36.5	17	25
1026000007	15	38	17	25
1026000008	16	39	17	10
1026000009	18	41.5	20	10
1026000010	22	43	27	10

10280

RACOR A L MACHO - ELBOW MALE ADAPTOR



Código Code	Tubo Tube	A	L1	L2	CH	Conf. Pack.
1028000001	4	1/8	20.5	15	8	50
1028000002	6	1/8	23.5	17	9	50
1028000003	6	1/4	23.5	19	9	50
1028000004	8	1/8	28	18	11	50
1028000005	8	1/4	28	21.5	11	25
1028000006	8	3/8	28.5	24	13	25
1028000007	10	1/4	32	23.5	13	25
1028000008	10	3/8	32	24.5	13	25
1028000009	10	1/2	34	25	14	25
1028000010	12	1/4	34	24	14	25
1028000011	12	3/8	34	26	14	25
1028000012	12	1/2	34	25	14	25
1028000013	14	3/8	38	26	17	25
1028000014	14	1/2	38	28.5	17	25
1028000015	15	1/2	39	28.5	17	25
1028000016	16	1/2	40	28	17	10
1028000017	18	1/2	42	29.5	20	10
1028000018	18	3/4	42	32	20	10
1028000019	22	3/4	42.5	34	27	10

10290

RACOR A L HEMBRA - ELBOW FEMALE ADAPTOR

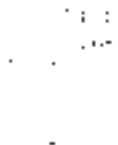

Código Code	Tubo Tube	A	L1	L2	CH	Conf. Pack.
1029000001	4	1/8	22	18	8	50
1029000002	6	1/8	23.5	18	9	50
1029000003	6	1/4	24	22.5	11	50
1029000004	8	1/8	28	21	11	50
1029000005	8	1/4	28.5	25.5	13	50
1029000006	8	3/8	29	25	14	25
1029000007	10	1/4	34	25	13	25
1029000008	10	3/8	33	25	14	25
1029000009	10	1/2	33	27	15	25
1029000010	12	1/4	34	26	14	25
1029000011	12	3/8	34	26	14	25
1029000012	12	1/2	33	27	15	25
1029000013	14	1/2	38.5	30	18	25
1029000014	15	1/2	39	30	18	25
1029000015	16	1/2	40	30	18	25
1029000016	18	1/2	42	29	20	10
1029000017	18	3/4	42	33.5	20	10

10460

RACOR RECTO INTERMEDIO - STRAIGHT CONNECTOR

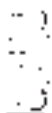

Código Code	Tubo Tube	L	CH	Conf. Pack.
1046000001	4	30.5	10	50
1046000002	6	35	11	50
1046000003	8	36	13	50
1046000004	10	43.5	16	25
1046000005	12	44	18	25
1046000006	14	47	21	25
1046000007	15	52	21	25
1046000008	16	52.5	22	25
1046000009	18	56.5	26	10
1046000010	22	55	30	10

10465

RACOR INTERMEDIO PASATABIQUES - BULKHEAD CONNECTOR



Código Code	Tubo Tube	L	L1MAX	CH1	CH2	Conf. Pack.
1046500001	4	46.5	15	10	13	25
1046500002	6	51.5	15	14	14	25
1046500003	8	53	15	14	17	25
1046500004	10	61.5	16	19	21	25
1046500005	12	67.5	20	22	24	25
1046500006	14	72	20	24	24	25

10480

RACOR RECTO MACHO CÓNICO - STRAIGHT MALE ADAPTOR (TAPER)



Código Code	Tubo Tube	A	L	CH	Conf. Pack.
104800001	4	1/8	25.5	11	50
104800002	4	1/4	28.5	14	50
104800003	6	1/8	27.5	11	50
104800004	6	1/4	31	14	50
104800005	6	3/8	31.5	17	50
104800006	8	1/8	28	13	50
104800007	8	1/4	31.5	14	25
104800008	8	3/8	32	17	25
104800009	10	1/4	35	16	25
104800010	10	3/8	35.5	17	25
104800011	10	1/2	37	21	25
104800012	12	1/4	36	18	25
104800013	12	3/8	37	18	25
104800014	12	1/2	37	21	25
104800015	14	3/8	37	20	25
104800016	14	1/2	39.5	21	25
104800017	15	1/2	40	21	25
104800018	16	1/2	42.5	22	10
104800019	16	3/4	44	27	10
104800020	18	1/2	44	24	10
104800021	18	3/4	45.5	27	10
104800022	22	1/2	44	30	10
104800023	22	3/4	45.5	30	10

10485

RACOR RECTO MACHO CILÍNDRICO - STRAIGHT MALE ADAPTOR (PARALLEL)

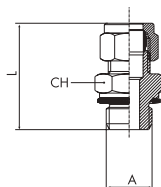

Código Code	Tubo Tube	A	L	CH	Conf. Pack.
104850001	4	1/8	25	13	25
104850002	6	1/8	26.5	13	25
104850003	6	1/4	30	17	25
104850004	8	1/8	28.5	13	25
104850005	8	1/4	31	17	25
104850006	8	3/8	34.5	22	25
104850007	10	1/4	34.5	17	25
104850008	10	3/8	38	22	25
104850009	14	3/8	39.5	22	25
104850010	14	1/2	42	27	25
104850011	22	3/4	47	32	10
104850012	22	1"	50	40	10

10500

RACOR RECTO HEMBRA - STRAIGHT FEMALE ADAPTOR



Código Code	Tubo Tube	A	L	CH	Conf. Pack.
105000001	4	1/8	24	14	50
105000002	4	1/4	26.5	17	50
105000003	6	1/8	25.5	14	50
105000004	6	1/4	28	17	50
105000005	8	1/8	26	14	50
105000006	8	1/4	28.5	17	50
105000007	8	3/8	29.5	20	25
105000008	10	1/4	32	17	25
105000009	10	3/8	32.5	20	25
105000010	10	1/2	34.5	24	25
105000011	12	1/4	32	18	25
105000012	12	3/8	32.5	20	25
105000013	12	1/2	34.5	24	25
105000014	14	3/8	34	20	25
105000015	14	1/2	36.5	24	25
105000016	15	1/2	36.5	24	25
105000017	16	1/2	39	24	10
105000018	16	3/4	40.5	30	10
105000019	18	1/2	40	24	10
105000020	18	3/4	41	30	10
105000021	22	3/4	40	30	10

10510

RACOR A CRUZ - EQUAL CROSS

Código Code	Tubo Tube	L	CH	Conf. Pack.
105100001	4	45	8	25
105100002	6	47	9	25
105100003	8	54	11	25
105100004	10	64	13	25
105100005	12	70	17	25
105100006	14	74.5	17	10

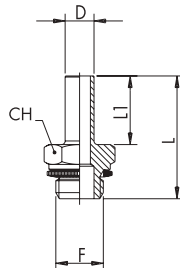
13530

ADAPTADOR ORIENTABLE MACHO CILÍNDRICO - ORIENTING MALE ADAPTOR PARALLEL

Código Code	D	F	L	L1	CH	Conf. Pack.
135300001	6	1/8	27.5	16	13	50
135300002	6	1/4	31	16	17	50
135300003	8	1/8	31.5	19	13	25
135300004	8	1/4	34	19	17	25
135300005	8	3/8	38	19	22	25
135300006	10	1/4	35	20	17	25
135300007	10	3/8	39	20	22	25
135300008	14	3/8	40	21	22	25
135300009	14	1/2	42	21	27	25

13540

MANGUITO PORTAGOMA PARA TUBO DE CAUCHO - SLEEVE HOSE ADAPTER FOR CAOUTCHOUC TUBES

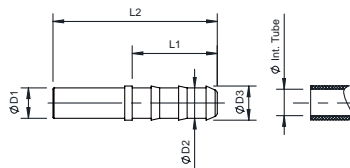

Código Code	D1	D2	L1	L	Conf. Pack.
135400001GG00	6	7	22.5	40.5	50
135400001GH00	8	7	22.5	43.5	50
135400001GP00	8	10	22.5	43.5	50
135400001GI00	10	7	22.5	44.5	25
135400001FR00	10	10	22.5	44.5	25
135400001FS00	12	10	22.5	45	25
135400001GM00	12	13	29.5	52	25
135400001GN00	14	13	29.5	52.5	25

10550

RACOR ORIENTABLE A L CON TORNILLO - SINGLE BANJO BODY WITH STEM

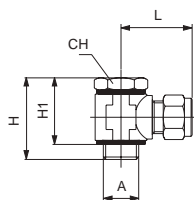

Código Code	Tubo Tube	A	L	H	H1	CH	Conf. Pack.
1055000001	4	1/8	21.5	31	23	14	25
1055000002	6	1/8	23	31	23	14	25
1055000003	6	1/4	26	32	23.5	17	25
1055000004	8	1/8	26.5	31	23	14	25
1055000005	8	1/4	27	32	23.5	17	25
1055000006	8	3/8	28	36	26.5	19	25
1055000007	10	1/4	31.5	32	23.5	17	25
1055000008	10	3/8	32.5	36	26.5	19	25
1055000009	14	1/4	36.5	44	36.5	17	25
1055000010	14	3/8	36.5	46	37	22	25
1055000011	14	1/2	36.5	49	38	24	10
1055000012	22	3/4	45.5	64	52	32	10

10680

TUERCA - NUT



Código Code	Tubo Tube	H	CH	M	Conf. Pack.
106800001X1NB	4	9.5	10	M8x1	50
106800001X4NB	6	10.5	12	M10x1	50
106800001X7NB	8	11.5	14	M12x1	50
106800001X9NB	10	13.5	19	M16x1.5	50
106800001Y1NB	12	13.5	21	M18x1.5	50
106800001Y3NB	14	14.5	23	M20x1.5	25
106800001Y4NB	15	16	23	M20x1.5	25
106800001Y5NB	16	17	25	M22x1.5	25
106800001Y7NB	18	18	28	M24x1.5	25
106800001J1NB	22	18	34	M30x1.5	10

10740

BICONO LATÓN - BRASS OLIVE



Código Code	Tubo Tube	H	Conf. Pack.
107400002X100	4	5.5	50
107400002X400	6	6.5	50
107400002X700	8	6.5	50
107400002X900	10	7.5	50
107400002Y100	12	8	50
107400002Y300	14	8.5	25
107400002Y400	15	9	25
107400002Y500	16	9.5	25
107400002Y700	18	10	25
107400002J100	22	10	10

10760

BICONO PTFE - PTFE OLIVE



Código Code	Tubo Tube	H	Conf. Pack.
107600028X100	4	5.5	50
107600028X400	6	6.5	50
107600028X700	8	6.5	50
107600028X900	10	7.5	50
107600028Y100	12	8	50
107600028Y300	14	8.5	50
107600028Y400	15	9	50
107600028Y500	16	9.5	50
107600028Y700	18	10	50
107600028J100	22	10	50

10770

REFUERZO - INTERNAL SUPPORT BUSH

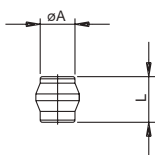

Código Code	Tubo Tube	A	B	C	L	Conf. Pack.
1077000011D00	4/2.7	2.7	1.5	3.8	13	50
1077000013D00	6/4	4	3	5	13	50
1077000014D00	8/6	6	5	7	16.5	50
1077000015D00	10/8	8	7	9	17	50
1077000017D00	12/9	9	8	11	19	50
1077000018D00	12/10	10	9	11	19	50
1077000010E00	14/12	12	11	13.5	21	50
1077000011E00	15/12.5	12.5	11.5	14	21	50
1077000013E00	16/13	13	12	15	22	50
1077000017E00	18/15	15	14	17.5	23	50
1077000018E00	18/16	16	15	17.5	23	50
1077000010F00	22/18	18	16.5	19	25	50

13780

TAPÓN PARA RACORES UNIVERSALES - PLUG FOR UNIVERSAL FITTINGS

Código Code	A	L	Conf. Pack.
137800001X100	4	10	50
137800001X400	6	10.5	50
137800001X700	8	10.5	50
137800001X900	10	11.5	50
137800001Y100	12	12	50
137800001Y300	14	14	25
137800001Y400	15	14	25
137800001Y500	16	14	25
137800001Y700	18	16	25
137800001J100	22	15	25

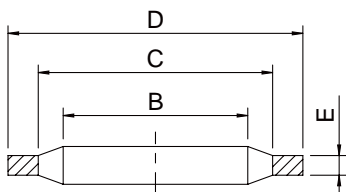
1612

ARANDELA BIMATERIAL EN ACERO Y NBR - STEEL AND NBR BIMATERIAL WASHER

CARACTERÍSTICAS TÉCNICAS / TECHNICAL CHARACTERISTICS

 Temperatura mínima / minimum temperature: **-30°C**
 Temperatura máxima / maximum temperature: **+100°C**

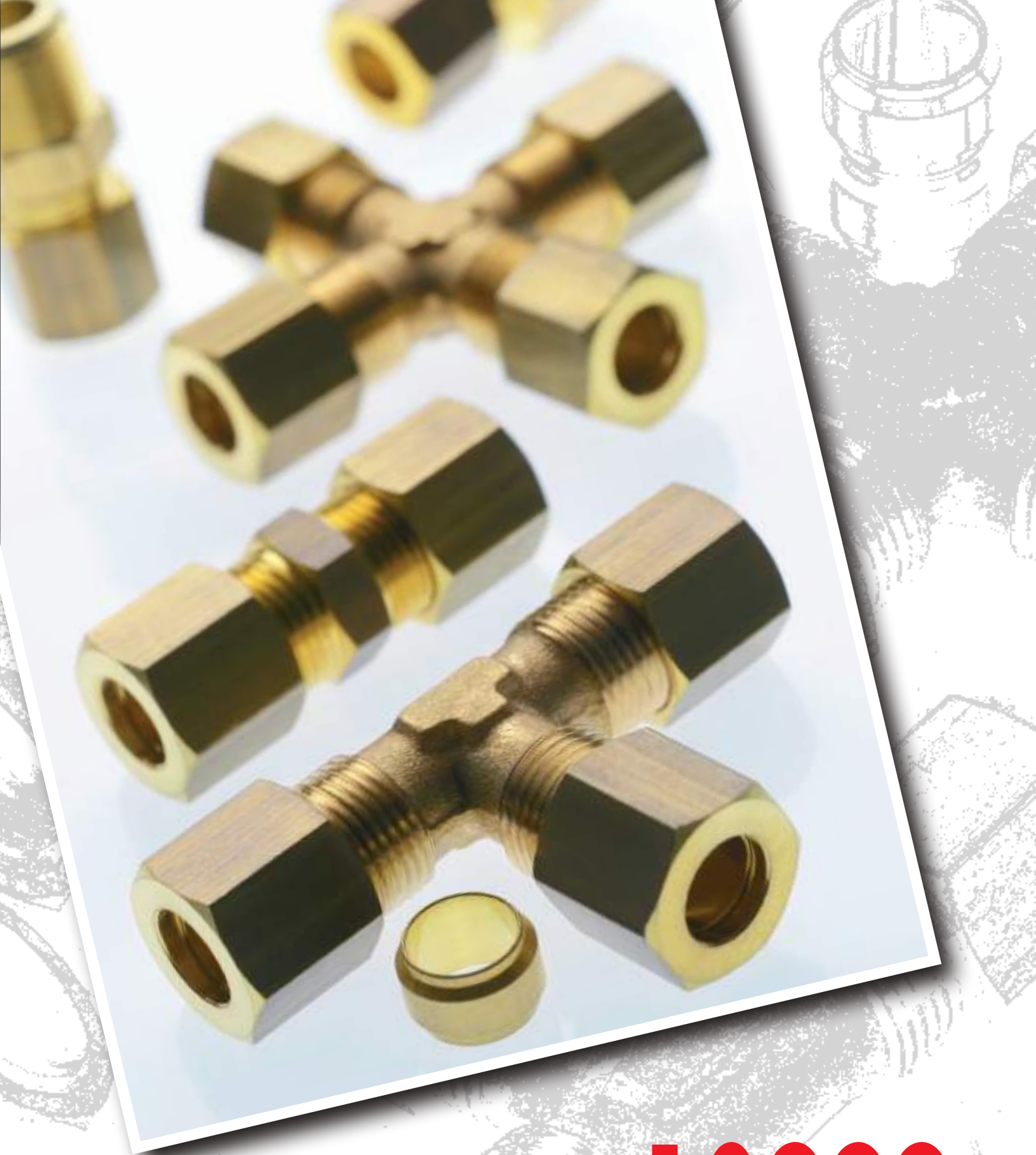
Código Code	A	B	C	D	E	Conf. Pack.
0161200001	1/8	10.4	12	14.7	1.25	25
0161200002	1/4	13.85	15.75	18.7	1.25	25
0161200003	3/8	17.35	19.25	22.7	1.25	25
0161200004	1/2	21.65	23.55	26.7	1.25	25
0161200005	3/4	27.3	29.2	32.5	1.25	25
0161200006	1"	34.2	36.1	39.5	2	25



Serie 13000

RACORDAJE UNIVERSAL
UNIVERSAL FITTINGS

Características Técnicas / Technical Characteristics

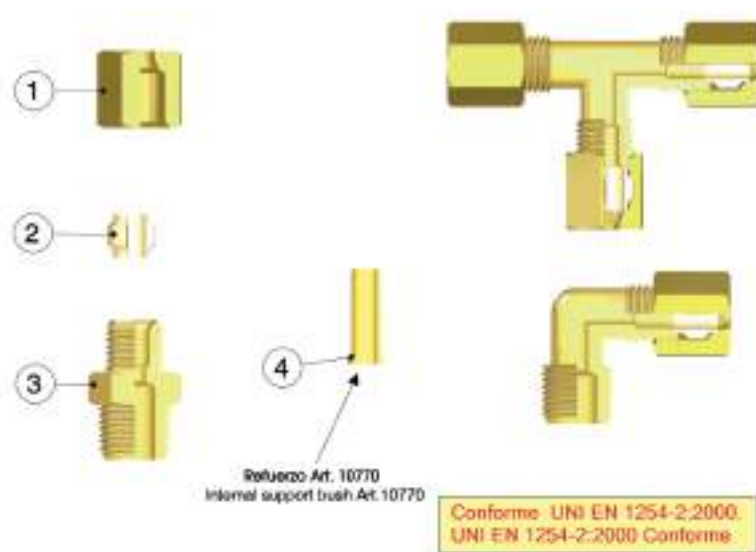

Materiales y Componentes / Component Parts and Materials

- | | |
|-------------------|-------------------------|
| 1 Tuerca en Latón | 1 Brass Nut |
| 2 Bicono en Latón | 2 Brass Olive |
| 3 Cuerpo en Latón | 3 Brass Body |
| 4 Refuerzo | 4 Internal support bush |

Presiones y Temperaturas / Pressures and Temperatures

Presión y temperatura vienen determinadas según el tipo de tubo empleado, por lo tanto estos valores se definen en base a las características del mismo tubo. Representamos a continuación los valores de las presiones máximas aconsejadas para la utilización de los racores con tubo de cobre espesor 1 mm a 20° C.

The working pressures and working temperatures depend on which type of tube is used, for this reason, the values must be determined in accordance with the tube's features. Hereunder, we specify the values of the maximum pressure advised for the fittings at a temperature of 20° C connected with copper tube, which has a thickness of 1 mm.

Los valores de las presiones aconsejadas, representadas en la tabla, han sido obtenidas de valores de prueba adoptando un coeficiente de seguridad 4. Están disponibles los certificados de las pruebas realizadas en distintos laboratorios especializados.

The values of working pressures advised, specified in table have been obtained from the test values using a Safety Factor 4. It is available the test report made by the external laboratory test.

TAMAÑO SIZE	PRESIÓN MÁXIMA ACONSEJADA MAXIMUM PRESSURE ADVISED
Ø 4	150 kg/cmq. - 148.4 Bar
Ø 6	150 kg/cmq. - 148.4 Bar
Ø 8	135 kg/cmq. - 133.6 Bar
Ø 10	95 kg/cmq. - 94 Bar
Ø 12	75 kg/cmq. - 74.2 Bar
Ø 14	100 kg/cmq. - 99 Bar
Ø 16	95 kg/cmq. - 94 Bar
Ø 18	70 kg/cmq. - 69.3 Bar
Ø 22	70 kg/cmq. - 69.3 Bar

Roscas / Threads

Gas cónica conforme ISO 7.1, BS 21, DIN 2999 / Tapered gas in conformity with ISO7.1, BS 21, DIN 2999.

Gas cilíndrica conforme ISO 228 / Parallel gas in conformity with ISO 228.

Métrica conforme ISO R/262 / Metric in conformity with ISO R/262.

Tubos de conexión / Connection Tubes

Tubos en cobre, hierro, acero, aluminio, latón, etc...

Con el correspondiente refuerzo interno pueden utilizarse también con tubo en PA11, PA6, etc...

Tubes made in copper, steel, iron, aluminium, brass, etc.
With an inside support bush (art. 10770), can be used also for plastic material such as PA11, PA6, ecc.

Fluidos compatibles / Fluids

Agua, aceite, aire comprimido, fluidos en general para instalaciones hidráulicas, oleodinámicas, hidroneumáticas, etc...

Water, oils, compressed air, fluids in general for the hydraulic, pneumatic and oildynamic plants etc.

13200

RACOR A T INTERMEDIO - TEE CONNECTOR



Código Code	Tubo Tube	L1	L2	CH	Conf. Pack.
132000001	4	44	22	8	25
132000002	6	48	24	9	25
132000003	8	57	28.5	12	25
132000004	10	64	32	13	25
132000005	12	69	35	14	25
132000006	14	78	39	18	10
132000007	15	77	38.5	18	10
132000008	16	78.5	39.5	17	10
132000009	18	83	41.5	20	10
132000010	22	89	44.5	27	10

13220

RACOR A T MACHO CENTRAL - TEE MALE ADAPTOR CENTRE LEG

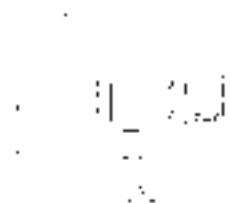

Código Code	Tubo Tube	A	L1	L2	CH	Conf. Pack.
132200001	4	1/8	45	15	8	50
132200002	6	1/8	48	16.5	9	25
132200003	6	1/4	48	20.5	9	25
132200004	8	1/8	57	16.5	12	25
132200005	8	1/4	57	20.5	12	25
132200006	8	3/8	61	23	13	25
132200007	10	1/4	64	22.5	13	25
132200008	10	3/8	64	23.5	13	25
132200009	10	1/2	68	27	14	25
132200010	12	1/4	69	24.5	14	25
132200011	12	3/8	69	25	14	25
132200012	12	1/2	69	26.5	14	25
132200013	14	3/8	74	26	16	25
132200014	14	1/2	77	31	18	25
132200015	15	1/2	78	31	18	25
132200016	16	1/2	78.5	29	17	10
132200017	18	1/2	83	29.5	20	10
132200018	18	3/4	83	32.5	20	10
132200019	22	3/4	89	34	27	10

13230

RACOR A T MACHO LATERAL - TEE MALE ADAPTOR OFF SET LEG

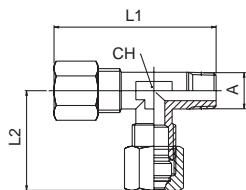

Código Code	Tubo Tube	A	L1	L2	CH	Conf. Pack.
132300001	4	1/8	37.5	22.5	8	50
132300002	6	1/8	40	25	9	25
132300003	6	1/4	44	24	9	25
132300004	8	1/8	45.5	28.5	12	25
132300005	8	1/4	49	28.5	12	25
132300006	8	3/8	52	28.5	13	25
132300007	10	1/4	55	32	13	25
132300008	10	3/8	55.5	32	13	25
132300009	12	3/8	58.5	35	14	25
132300010	12	1/2	60	35.5	15	25
132300011	14	1/2	67	38.5	18	25

13240

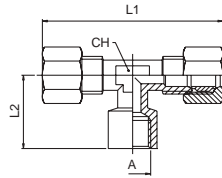
RACOR A T HEMBRA CENTRAL - TEE FEMALE CENTRE LEG

Código Code	Tubo Tube	A	L1	L2	CH	Conf. Pack.
1324000001	4	1/8	45	18	8	50
1324000002	6	1/8	47.5	19.5	9	50
1324000003	6	1/4	56	24.5	13	50
1324000004	8	1/8	57	19.5	12	50
1324000005	8	1/4	59	24.5	13	50
1324000007	10	1/4	64	24.5	13	25
1324000008	10	3/8	58	26	14	25
1324000009	10	1/2	69	26	15	25
1324000010	12	1/4	69	25.5	14	25
1324000011	12	3/8	69	26	14	25
1324000012	12	1/2	70	26	15	25
1324000013	14	1/2	77	30	18	25
1324000014	15	1/2	78	30	18	25
1324000015	16	1/2	77.5	28.5	17	10
1324000016	18	1/2	83	28	20	10
1324000017	18	3/4	83	34	20	10

13260

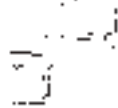
RACOR A L INTERMEDIO - ELBOW CONNECTOR

Código Code	Tubo Tube	L	CH	Conf. Pack.
1326000001	4	21.5	8	50
1326000002	6	24	9	50
1326000003	8	30	11	25
1326000004	10	33	13	25
1326000005	12	36	14	25
1326000006	14	37	17	25
1326000007	15	38	17	25
1326000008	16	39.5	17	10
1326000009	18	41.5	20	10
1326000010	22	44.5	27	10

13280

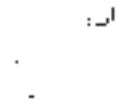
RACOR A L MACHO - ELBOW MALE ADAPTOR

Código Code	Tubo Tube	A	L1	L2	CH	Conf. Pack.
1328000001	4	1/8	21.5	15	8	50
1328000002	6	1/8	24	17	9	50
1328000003	6	1/4	24	19	9	50
1328000004	8	1/8	30	18	11	50
1328000005	8	1/4	30	21.5	11	50
1328000006	8	3/8	30.5	24	13	25
1328000007	10	1/4	33	23.5	13	25
1328000008	10	3/8	33	24.5	13	25
1328000009	10	1/2	35	25	14	25
1328000010	12	1/4	36	24	14	25
1328000011	12	3/8	36	26	14	25
1328000012	12	1/2	36	25	14	25
1328000013	14	3/8	39	26	17	25
1328000014	14	1/2	39	28.5	17	25
1328000015	15	1/2	39	28.5	17	25
1328000016	16	1/2	40	28	17	10
1328000017	18	1/2	41.5	29.5	20	10
1328000018	18	3/4	41.5	32	20	10
1328000019	22	3/4	44.5	34	27	10

13290

RACOR A L HEMBRA - ELBOW FEMALE ADAPTOR

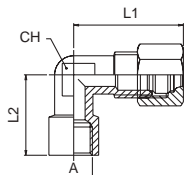

Código Code	Tubo Tube	A	L1	L2	CH	Conf. Pack.
1329000001	4	1/8	23	18	8	50
1329000002	6	1/8	24	18	9	50
1329000003	6	1/4	24.5	22.5	11	50
1329000004	8	1/8	30	21	11	50
1329000005	8	1/4	30.5	25.5	13	50
1329000006	8	3/8	31	25	14	25
1329000007	10	1/4	34	25	13	50
1329000008	10	3/8	34	25	14	50
1329000009	10	1/2	34	27	15	50
1329000010	12	1/4	36	26	14	25
1329000011	12	3/8	36	26	14	25
1329000012	12	1/2	36	27	15	25
1329000013	14	1/2	39	30	18	25
1329000014	15	1/2	39	30	18	25
1329000015	16	1/2	41.5	30	18	10
1329000016	18	1/2	41.5	29	20	10
1329000017	18	3/4	44.5	33.5	20	10

13460

RACOR RECTO INTERMEDIO - STRAIGHT CONNECTOR



Código Code	Tubo Tube	L	CH	Conf. Pack.
1346000001	4	33	10	50
1346000002	6	36	11	50
1346000003	8	40	13	50
1346000004	10	45.5	16	25
1346000005	12	47	18	25
1346000006	14	47.5	21	25
1346000007	15	52	21	25
1346000008	16	52.5	22	25
1346000009	18	56	26	10
1346000010	22	58.5	30	10

13465

RACOR INTERMEDIO PASATABIQUES - BULKHEAD CONNECTOR

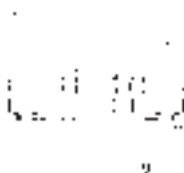

Código Code	Tubo Tube	L	L MAX	CH1	CH2	Conf. Pack.
1346500001	4	49	12	10	13	25
1346500002	6	52.5	12.5	13	14	25
1346500003	8	56.5	12.5	14	17	25
1346500004	10	63.5	13	19	22	25
1346500005	12	70.5	17	22	22	25
1346500006	14	72.5	19	24	24	25

13480

RACOR RECTO MACHO CÓNICO - STRAIGHT MALE ADAPTOR (TAPER)

Código Code	Tubo Tube	A	L	CH	Conf. Pack.
134800001	4	1/8	26.5	11	50
134800002	4	1/4	29.5	14	50
134800003	6	1/8	28	11	50
134800004	6	1/4	31.5	14	50
134800005	6	3/8	32	17	50
134800006	8	1/8	30	13	50
134800007	8	1/4	33.5	14	25
134800008	8	3/8	34	17	25
134800009	10	1/4	36	16	25
134800010	10	3/8	36.5	17	25
134800011	10	1/2	38	21	25
134800012	12	1/4	37	18	25
134800013	12	3/8	37.5	18	25
134800014	12	1/2	39	21	25
134800015	14	3/8	37.5	20	25
134800016	14	1/2	40	21	25
134800017	15	1/2	40	21	25
134800018	16	1/2	42.5	22	10
134800019	16	3/4	44	27	10
134800020	18	1/2	43.5	24	10
134800021	18	3/4	45	27	10
134800022	22	1/2	46	30	10
134800023	22	3/4	47.5	30	10

13485

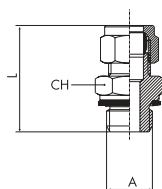
RACOR RECTO MACHO CILÍNDRICO - STRAIGHT MALE ADAPTOR (PARALLEL)

Código Code	Tubo Tube	A	L	CH	Conf. Pack.
134850001	4	1/8	26	13	25
134850002	6	1/8	27	13	25
134850003	6	1/4	30.5	17	25
134850004	8	1/8	30	13	25
134850005	8	1/4	32.5	17	25
134850006	8	3/8	36.5	22	25
134850007	10	1/4	35	17	25
134850008	10	3/8	39	22	25
134850009	14	3/8	40	22	25
134850010	14	1/2	42	27	25
134850011	22	3/4	49	32	10
134850012	22	1"	52	40	10

13500

RACOR RECTO HEMBRA - STRAIGHT FEMALE ADAPTOR

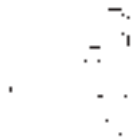

Código Code	Tubo Tube	A	L	CH	Conf. Pack.
135000001	4	1/8	25	14	50
135000002	4	1/4	27.5	17	50
135000003	6	1/8	26	14	50
135000004	6	1/4	28.5	17	50
135000005	8	1/8	28	14	50
135000006	8	1/4	30.5	17	50
135000007	8	3/8	31.5	20	25
135000008	10	1/4	33	17	25
135000009	10	3/8	33.5	20	25
135000010	10	1/2	35.5	24	25
135000011	12	1/4	34	18	25
135000012	12	3/8	34.5	20	25
135000013	12	1/2	34	24	25
135000014	14	3/8	36.5	20	25
135000015	14	1/2	34	24	25
135000016	15	1/2	36.5	24	25
135000017	16	1/2	39	24	10
135000018	16	3/4	40.5	30	10
135000019	18	1/2	40	24	10
135000020	18	3/4	41.5	30	10
135000021	22	3/4	41.5	30	10

13510

RACOR A CRUZ - EQUAL CROSS



Código Code	Tubo Tube	L	CH	Conf. Pack.
135100001	4	47	8	25
135100002	6	48	9	25
135100003	8	58	11	25
135100004	10	66	13	25
135100005	12	74.5	17	25
135100006	14	74.5	17	10

13530

ADAPTADOR ORIENTABLE MACHO CILÍNDRICO - ORIENTING MALE ADAPTOR PARALLEL

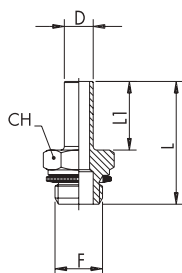

Código Code	D	F	L	L1	CH	Conf. Pack.
135300001	6	1/8	27.5	16	13	50
135300002	6	1/4	31	16	17	50
135300003	8	1/8	31.5	19	13	25
135300004	8	1/4	34	19	17	25
135300005	8	3/8	38	19	22	25
135300006	10	1/4	35	20	17	25
135300007	10	3/8	39	20	22	25
135300008	14	3/8	40	21	22	25
135300009	14	1/2	42	21	27	25

13540

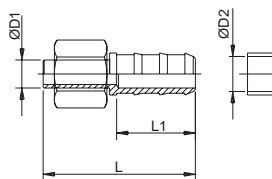
MANGUITO PORTAGOMA PARA TUBO DE CAUCHO - SLEEVE HOSE ADAPTER FOR CAOUTCHOUC TUBES

Código Code	D1	D2	L1	L	Conf. Pack.
135400001GG00	6	7	22.5	40.5	50
135400001GH00	8	7	22.5	43.5	50
135400001GP00	8	10	22.5	43.5	50
135400001GI00	10	7	22.5	44.5	25
135400001FR00	10	10	22.5	44.5	25
135400001FS00	12	10	22.5	45	25
135400001GM00	12	13	29.5	52	25
135400001GN00	14	13	29.5	52.5	25

13550

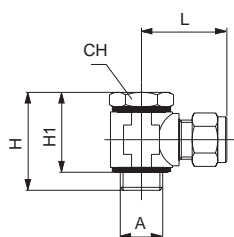
RACOR ORIENTABLE A L CON TORNILLO - SINGLE BANJO BODY WITH STEM

Código Code	Tubo Tube	A	L	H	H1	CH	Conf. Pack.
1355000001	4	1/8	22.5	31	24.5	14	25
1355000002	6	1/8	23.5	31	24.5	14	25
1355000003	6	1/4	26.5	32	25	17	25
1355000004	8	1/8	28.5	31	24.5	14	25
1355000005	8	1/4	28.5	32	25	17	25
1355000006	8	3/8	30	36	27.5	19	25
1355000007	10	1/4	32.5	32	25	17	25
1355000008	10	3/8	32.5	36	27.5	19	25
1355000009	14	1/4	37	44	38	17	25
1355000010	14	3/8	37	46	38	22	25
1355000011	14	1/2	37	49	39.5	24	10
1355000012	22	3/4	47	64	55	32	10

13600

REDUCCIÓN - REDUCTION

Código Code	Ø	D	CH	Conf. Pack.
1360000001	4	6	13	10
1360000002	6	8	14	10
1360000003	8	10	19	10
1360000004	10	12	22	10
1360000005	12	14	24	10

Questo articolo è comprensivo di tre particolari quali: Tuerca, Bicono, Riduzione.
This article is comprehensive of 3 parts: Nut, Olive, Reduction.

13680

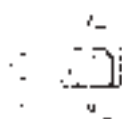
TUERCA - NUT

Código Code	Tubo Tube	H	CH	M	Conf. Pack.
136800001X100	4	10.5	10	M8x1	50
136800001X400	6	10.5	13	M10x1	50
136800001X700	8	12.5	14	M12x1	50
136800001X900	10	15	19	M16x1.5	50
136800001Y100	12	15	22	M18x1.5	50
136800001Y300	14	15	24	M20x1.5	25
136800001Y400	15	15	24	M20x1.5	25
136800001Y500	16	17	27	M22x1.5	25
136800001Y700	18	18	30	M24x1.5	25
136800001J100	22	19	36	M30x1.5	10

13740

BICONO LATÓN - BRASS OLIVE



Código Code	Tubo Tube	H	Conf. Pack.
137400001X100	4	6	50
137400001X400	6	6.5	50
137400001X700	8	7	50
137400001X900	10	8	50
137400001Y100	12	8.5	50
137400001Y300	14	8.5	25
137400001Y400	15	8.5	25
137400001Y500	16	9	25
137400001Y700	18	9.5	25
137400001J100	22	10	10

13780

TAPÓN PARA RACORES UNIVERSALES - PLUG FOR UNIVERSAL FITTINGS

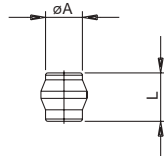

Código Code	A	L	Conf. Pack.
137800001X100	4	10	50
137800001X400	6	10.5	50
137800001X700	8	10.5	50
137800001X900	10	11.5	50
137800001Y100	12	12	50
137800001Y300	14	14	25
137800001Y400	15	14	25
137800001Y500	16	14	25
137800001Y700	18	16	25
137800001J100	22	15	25

1612

ARANDELA BIMATERIAL EN ACERO Y NBR - STEEL AND NBR BIMATERIAL WASHER

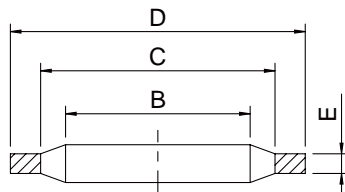

CARACTERÍSTICAS TÉCNICAS / TECHNICAL CHARACTERISTICS

Temperatura mínima / minimum temperature: -30°C
 Temperatura máxima / maximum temperature: +100°C

Código Code	A	B	C	D	E	Conf. Pack.
0161200001	1/8	10.4	12	14.7	1.25	25
0161200002	1/4	13.85	15.75	18.7	1.25	25
0161200003	3/8	17.35	19.25	22.7	1.25	25
0161200004	1/2	21.65	23.55	26.7	1.25	25
0161200005	3/4	27.3	29.2	32.5	1.25	25
0161200006	1"	34.2	36.1	39.5	2	25

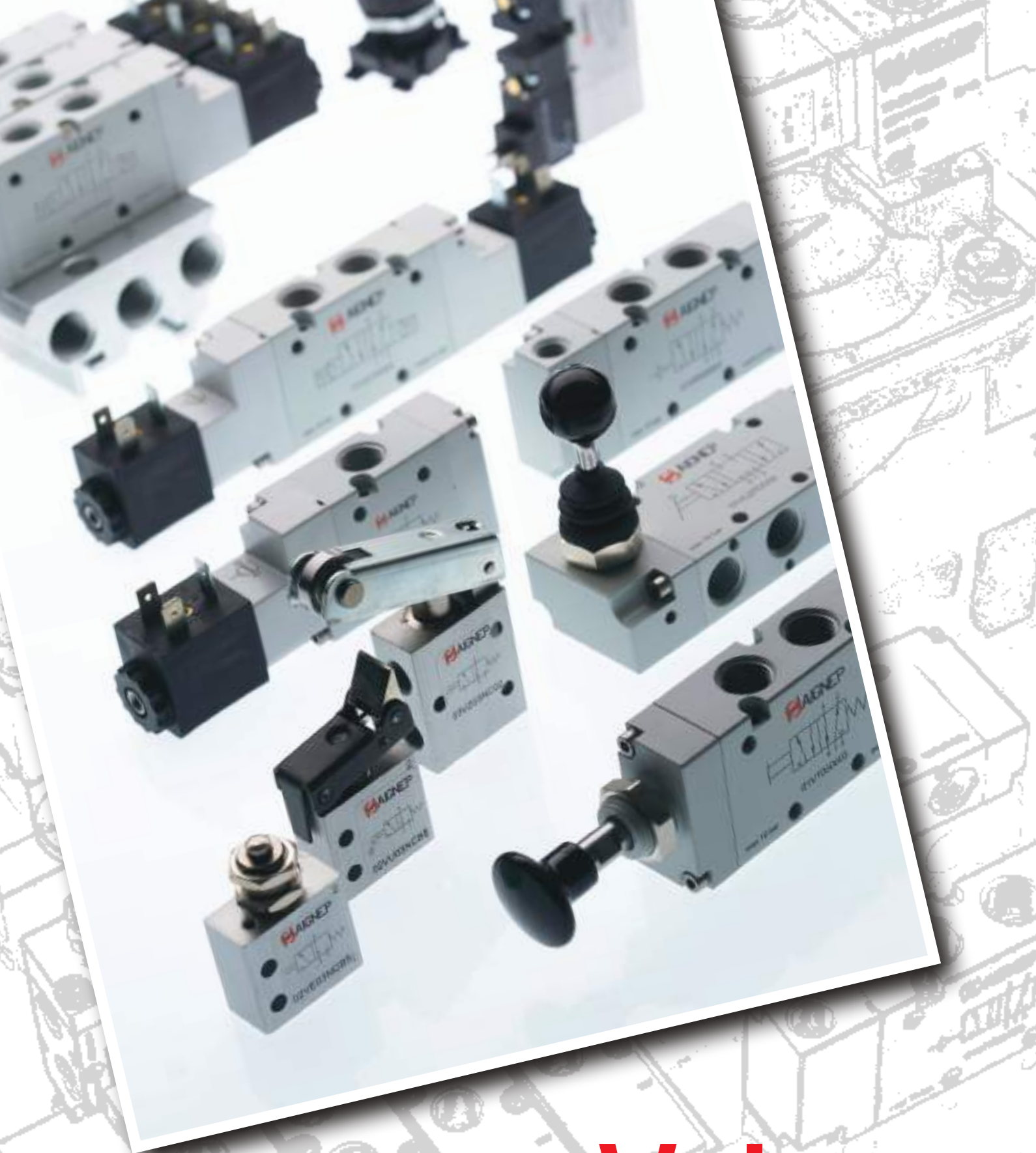

Serie Valves

VÁLVULAS ELECTRONEUMÁTICAS, NEUMÁTICAS Y MANUALES
MANUAL, PNEUMATIC AND SOLENOID PILOT VALVE

15.5
Serie 01V
Válvulas Electroneumáticas, Neumáticas, Manuales
Manual, Pneumatic and Solenoid pilot Valve

15.33
Serie 02V
Microválvulas
Micro Valve

15.37
Serie 03V
Válvulas 16 mm
16 mm Valve

15.41
Serie 04V
Válvulas de Panel, Pulsadores, Selectores
Panel Valve, Push Buttons and Selectors

15.45
Serie 05V
Válvulas VDMA 18 mm
18 mm VDMA Valve

15.53
Serie 06V
Válvulas a Pedal
Pedal Valve

15.55

Serie 07V

Electropilotos
Solenoid Valve



15.59

Serie 08V

Válvulas NAMUR
NAMUR Valve





Serie 01V

Válvulas Electroneumáticas, Neumáticas y Manuales
MANUAL, PNEUMATIC AND SOLENOID PILOT VALVE

Válvulas de accionamiento Electroneumático / Solenoid Pilot Valve



Características Técnicas - Technical Characteristics

ROSCA / THREADED

CAUDAL A 6 BAR CON Δp 1 bar

6 bar FLOW RATE WITH Δp 1 bar

PRESIÓN DE EJERCICIO / OPERATING PRESSURE

TEMPERATURA / TEMPERATURE

MATERIALES / MATERIAL

TENSIÓN SOLENOIDE / SOLENOID VOLTAGE

POTENCIA MÍNIMA / MINIMUM POWER

COMANDO MANUAL / MANUAL CONTROL

PAR DE APRIETE TUERCA SOBRE LA BOBINA

TORQUE OF TIGHTENING THE NUT SOLENOID

1/8

1/8
740 NI/min

1/4

1/4
1200 NI/min

1/2

1/2
5000 NI/min

MONOESTABLE / MONOSTABLE: 2 - 10 Bar

BIESTABLE / BIESTABLE: 1 - 10 Bar

-10° / +60° C

CUERPO EN ALUMINIO ANODIZADO Y BARNIZADO

ANODISED AND PAINTED ALUMINIUM BODY

CORREDERA EN ALUMINIO NIQUELADO QUÍMICAMENTE

CHEMICAL NICKEL-PLATED SPOOL

JUNTAS EN NBR

NBR SEALS

24V DC - 12V DC - 24V AC - 110V AC - 220V AC

2W - 3VA

BIESTABLE / BIESTABLE

0.6 Nm

Tabla de codificación para pedidos - Article codes to be used for ordering

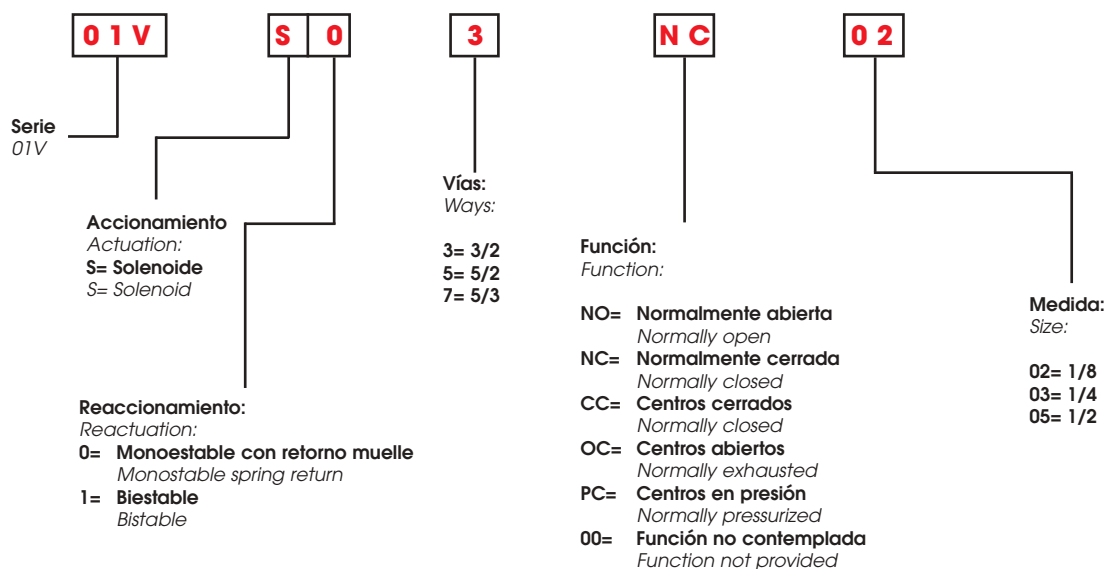

Válvulas de accionamiento Electroneumático / Solenoid Pilot Valve



01V S0 3 NC 02
01V S0 3 NC 03
01V S0 3 NC 05

01V S0 3 NO 02
01V S0 3 NO 03
01V S0 3 NO 05

3/2 Vías/Ways

MONOESTABLE CON RETORNO POR MUELLE
MONOSTABLE SPRING RETURN

CÓDIGO CODE	VÍAS WAYS	FUNCIÓN FUNCTION	MEDIDA SIZE
01V S0 3 NC 02	3/2	NC	1/8
01V S0 3 NC 03	3/2	NC	1/4
01V S0 3 NC 05	3/2	NC	1/2
01V S0 3 NO 02	3/2	NO	1/8
01V S0 3 NO 03	3/2	NO	1/4
01V S0 3 NO 05	3/2	NO	1/2



01V S0 3 NC 02 01V S0 3 NO 02

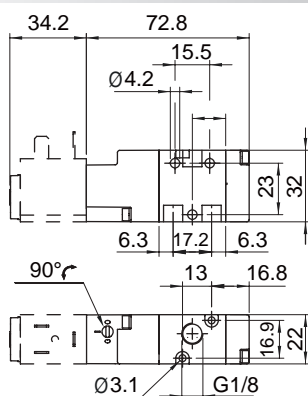

01V S0 3 NC 05 01V S0 3 NO 05

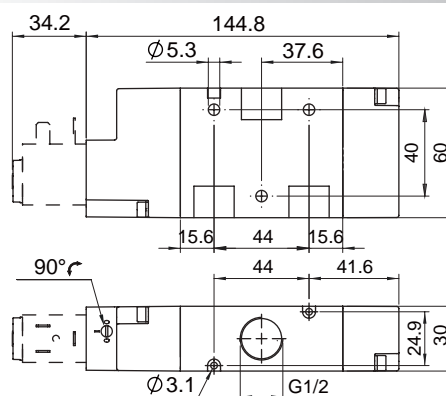

01V S0 3 NC 03 01V S0 3 NO 03

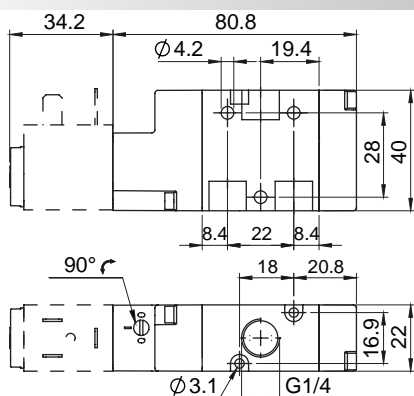

Válvulas de accionamiento Electroneumático / Solenoid Pilot Valve

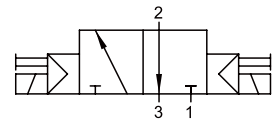

01V S1 3 00 02
01V S1 3 00 03
01V S1 3 00 05



3/2 Vías/Ways

BIESTABLE
TWO STABLE POSITIONS

CÓDIGO CODE	VÍAS WAYS	MEDIDA SIZE
01V S1 3 00 02	3/2	1/8
01V S1 3 00 03	3/2	1/4
01V S1 3 00 05	3/2	1/2

01V S1 3 00 02

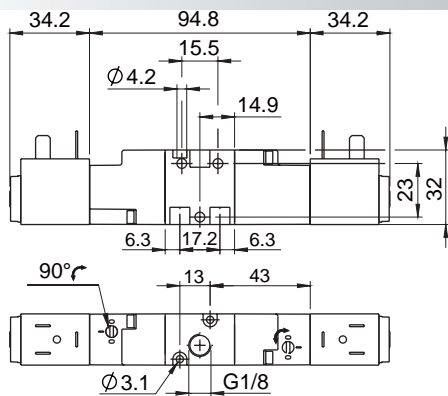

01V S1 3 00 05

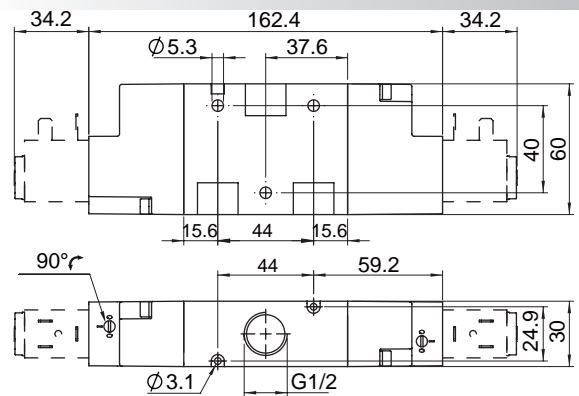

01V S1 3 00 03

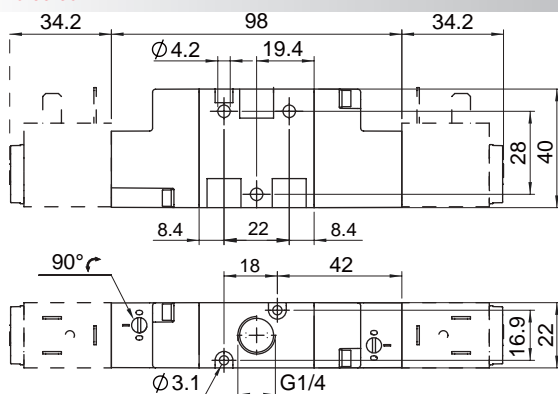

Válvulas de accionamiento Electroneumático / Solenoid Pilot Valve

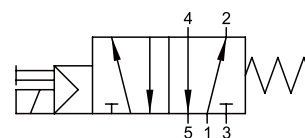

01V SO 5 00 02
01V SO 5 00 03
01V SO 5 00 05



5/2 Vías/Ways

MONOESTABLE CON RETORNO POR MUELLE
MONOSTABLE SPRING RETURN

CÓDIGO CODE	VÍAS WAYS	MEDIDA SIZE
01V SO 5 00 02	5/2	1/8
01V SO 5 00 03	5/2	1/4
01V SO 5 00 05	5/2	1/2

01V SO 5 00 02

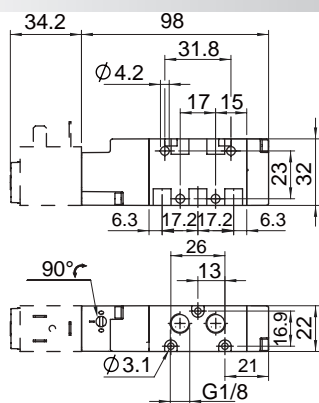

01V SO 5 00 05

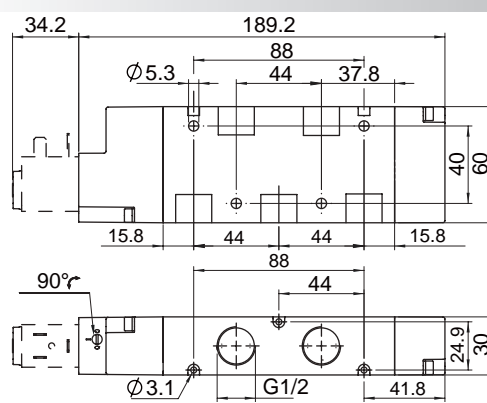

01V SO 5 00 03

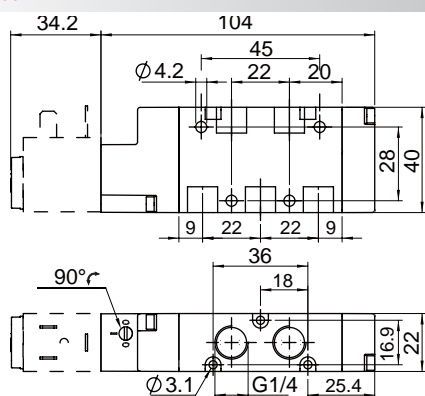

Válvulas de accionamiento Electroneumático / Solenoid Pilot Valve

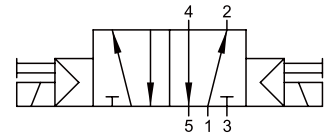

01V S1 5 00 02
01V S1 5 00 03
01V S1 5 00 05



5/2 Vías/Ways

BIESTABLE
TWO STABLE POSITIONS

CÓDIGO CODE	VÍAS WAYS	MEDIDA SIZE
01V S1 5 00 02	5/2	1/8
01V S1 5 00 03	5/2	1/4
01V S1 5 00 05	5/2	1/2

01V S1 5 00 02

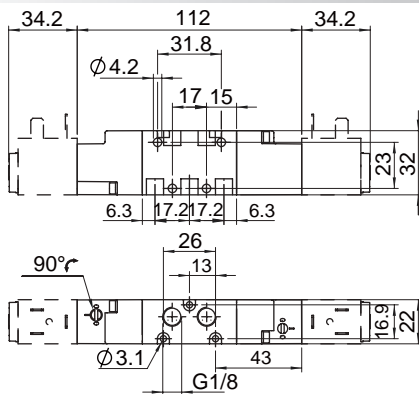

01V S1 5 00 05

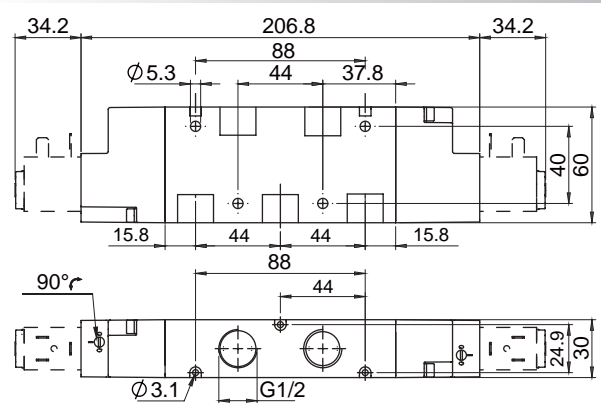

01V S1 5 00 03

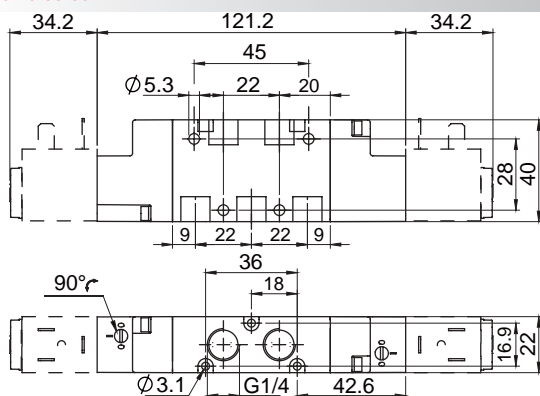

Válvulas de accionamiento Electroneumático / Solenoid Pilot Valve

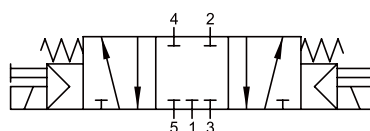

01V S0 7 CC 02
01V S0 7 CC 03
01V S0 7 CC 05

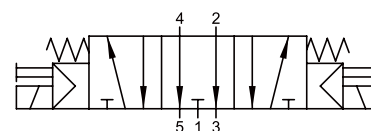

01V S0 7 OC 02
01V S0 7 OC 03
01V S0 7 OC 05

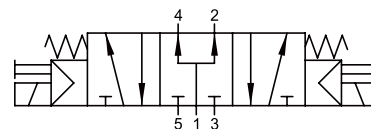

01V S0 7 PC 02
01V S0 7 PC 03
01V S0 7 PC 05



5/3 Vías/Ways

MONOESTABLE CON RETORNO POR MUELLE
MONOSTABLE SPRING RETURN

CÓDIGO CODE	VÍAS WAYS	FUNCIÓN FUNCTION	MEDIDA SIZE
01V S0 7 CC 02	5/3	CC	1/8
01V S0 7 CC 03	5/3	CC	1/4
01V S0 7 CC 05	5/3	CC	1/2
01V S0 7 OC 02	5/3	OC	1/8
01V S0 7 OC 03	5/3	OC	1/4
01V S0 7 OC 05	5/3	OC	1/2
01V S0 7 PC 02	5/3	PC	1/8
01V S0 7 PC 03	5/3	PC	1/4
01V S0 7 PC 05	5/3	PC	1/2

01V S0 7 CC 02 01V S0 7 OC 02 01V S0 7 PC 02

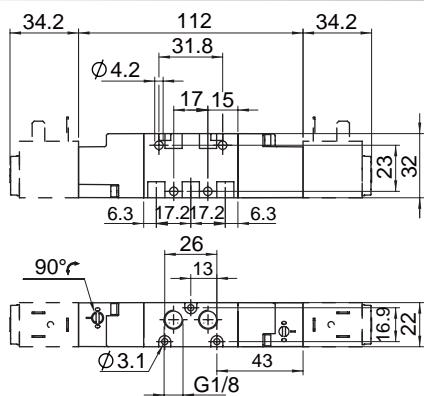

01V S0 7 CC 05 01V S0 7 OC 05 01V S0 7 PC 05

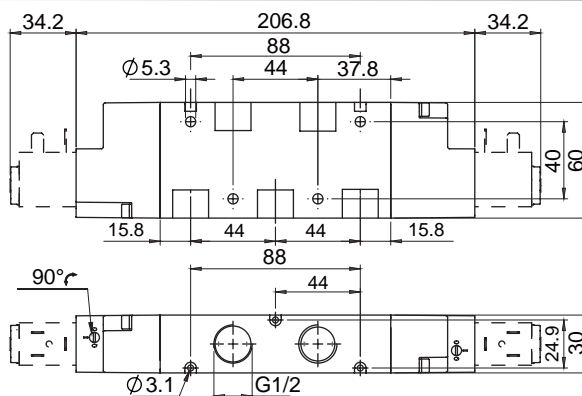

01V S0 7 CC 03 01V S0 7 OC 03 01V S0 7 PC 03

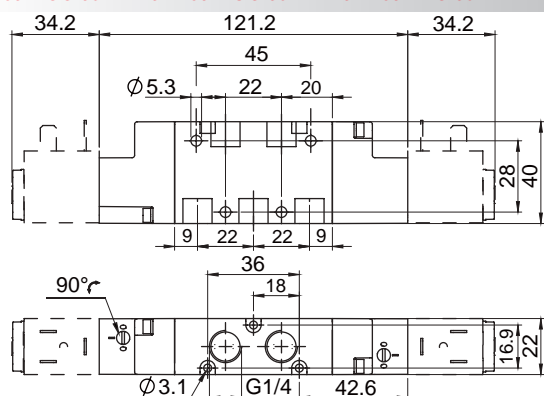

Bobinas y Conectores / Solenoids and Connectors

Bobinas Solenoids

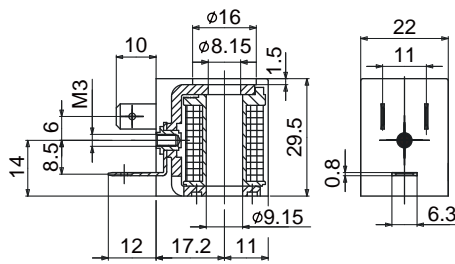

CÓDIGO CODE	TENSIÓN BOBINA SOLENOID VOLTAGE	POTENCIA POWER
SOL01012C1000	12V DC	3W
SOL01024C1000	24V DC	3W
SOL01024C3000	24V DC	2W
SOL01024A2000	24V AC	5VA
SOL01110A2000	110V AC	5VA
SOL01220A2000	220V AC	5VA

Bobina aconsejada
Solenoid Recommended

Características Técnicas - Technical Characteristics

TOLERANCIA DE TENSIÓN / VOLTAGE TOLERANCE
CLASE DE AISLAMIENTO / CLASS OF ISOLATION
GRADO DE PROTECCIÓN / DEGREE OF PROTECTION
CICLO DE TRABAJO / DUTY CYCLE
TERMINALES / TERMINALS

±10%
F CEI EN 60085
IP65 IEC 60529 CON CONECTOR (WITH CONNECTOR)
100%
DIN 43650 B

Conectores Connectors

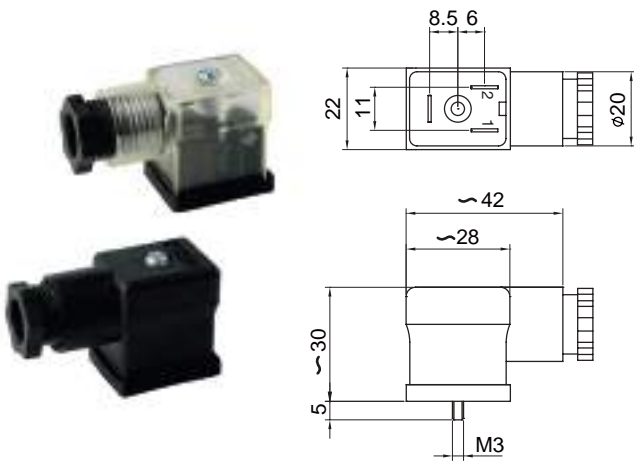

CÓDIGO CODE	COLOR COLOR	CATACTERÍSTICAS CHARACTERISTICS
CON0100001	NEGRO / BLACK	STANDARD A 2 POLOS (2 PIN)
CON0202400	TRANSPARENTE / TRANSPARENT	LED + VDR 0 - 24V
CON0211000	TRANSPARENTE / TRANSPARENT	LED + VDR 110V
CON0225000	TRANSPARENTE / TRANSPARENT	LED + VDR 220V

VDR: Dotado de Varistor como dispositivo de protección de sobretensiones.
Fitted with varistors as surge protection device.

ESQUEMA ELÉCTRICO / WIRING

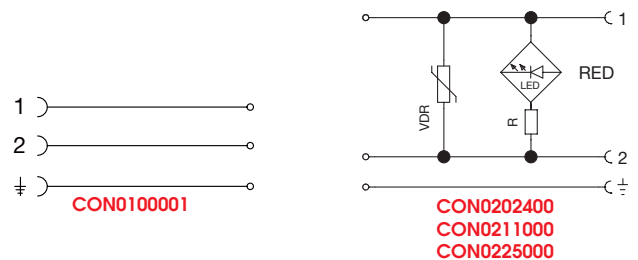

Características Técnicas - Technical Characteristics

GRADO DE PROTECCIÓN / DEGREE OF PROTECTION
JUNTA / GASKET
DIÁMETRO DEL CABLE / CABLE DIAMETER

IP65 IEC 60529
JUNTA DE PERFIL / PROFIL GASKET
6 ÷ 8 mm

Válvulas de accionamiento Neumático / Pneumatic Valve

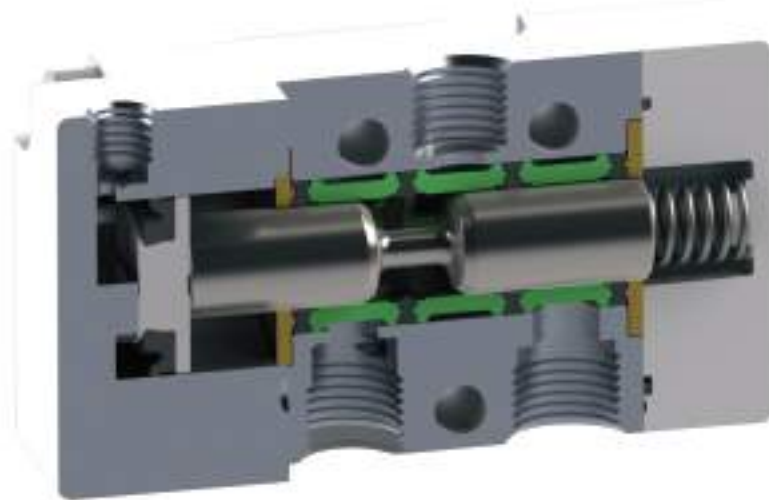

Características Técnicas - Technical Characteristics

ROSCAS / THREADED

CAUDAL A 6 BAR CON Δp 1 bar

6 bar FLOW RATE WITH Δp 1 bar

PRESIÓN DE EJERCICIO / OPERATING PRESSURE

PRESIÓN DE ACCIONAMIENTO / PRESSURE DRIVE

TEMPERATURA / TEMPERATURE

MATERIALES / MATERIAL

1/8

1/8
740 NI/min

1/4

1/4
1200 NI/min

1/2

1/2
5000 NI/min

0 - 10 Bar

MONOESTABLE / MONOSTABLE: 2 - 10 Bar

BIESTABLE / BIESTABLE: 1 - 10 Bar

-10° / +60° C

CUERPO EN ALUMINIO ANODIZADO Y BARNIZADO

ANODISED AND PAINTED ALUMINIUM BODY

CORREDERA EN ALUMINIO NIQUELADO QUÍMICAMENTE

CHEMICAL NICKEL-PLATED SPOOL

JUNTAS EN NBR

NBR SEALS

Tabla de codificación para pedidos - Article codes to be used for ordering

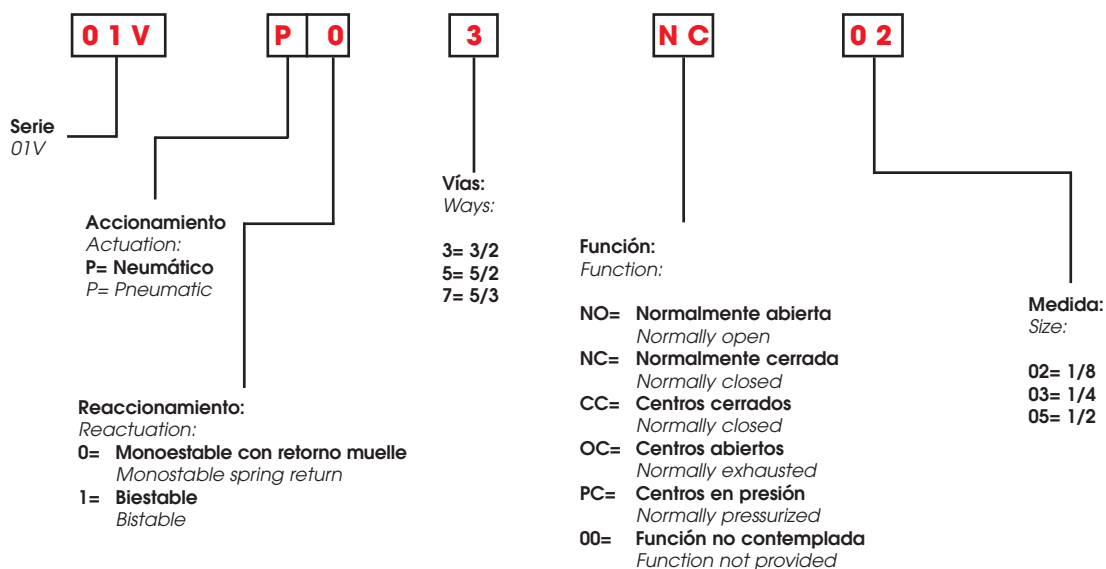

Válvulas de accionamiento Neumático / Pneumatic Valve

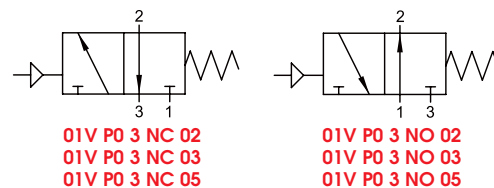

01V P0 3 NC 02
01V P0 3 NC 03
01V P0 3 NC 05

01V P0 3 NO 02
01V P0 3 NO 03
01V P0 3 NO 05



3/2 Vías/Ways

MONOESTABLE CON RETORNO POR MUELLE
MONOSTABLE SPRING RETURN

CÓDIGO CODE	VÍAS WAYS	FUNCIÓN FUNCTION	MEDIDA SIZE
01V P0 3 NC 02	3/2	NC	1/8
01V P0 3 NC 03	3/2	NC	1/4
01V P0 3 NC 05	3/2	NC	1/2
01V P0 3 NO 02	3/2	NO	1/8
01V P0 3 NO 03	3/2	NO	1/4
01V P0 3 NO 05	3/2	NO	1/2

01V P0 3 NC 02 01V P0 3 NO 02

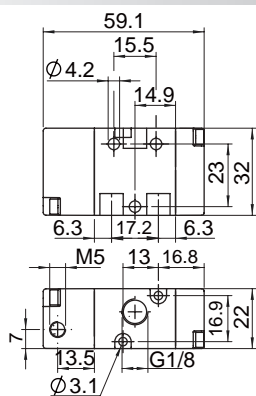

01V P0 3 NC 05 01V P0 3 NO 05

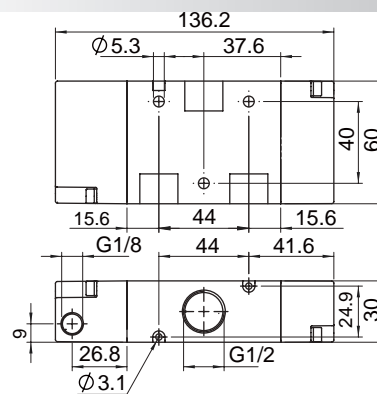

01V P0 3 NC 03 01V P0 3 NO 03

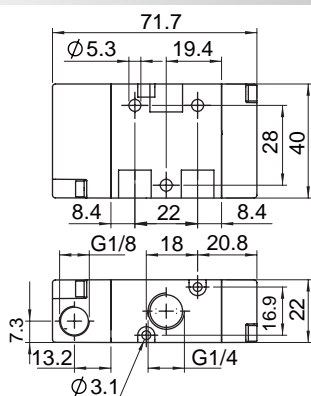

Válvulas de accionamiento Neumático / Pneumatic Valve

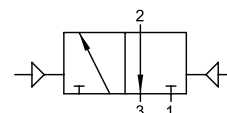

01V P1 3 00 02
01V P1 3 00 03
01V P1 3 00 05



3/2 Vías/Ways

BIESTABLE
TWO STABLE POSITIONS

CÓDIGO CODE	VÍAS WAYS	MEDIDA SIZE
01V P1 3 00 02	3/2	1/8
01V P1 3 00 03	3/2	1/4
01V P1 3 00 05	3/2	1/2

01V P1 3 00 02

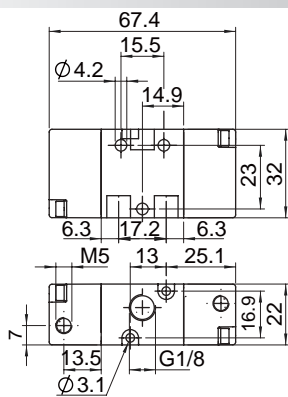

01V P1 3 00 05

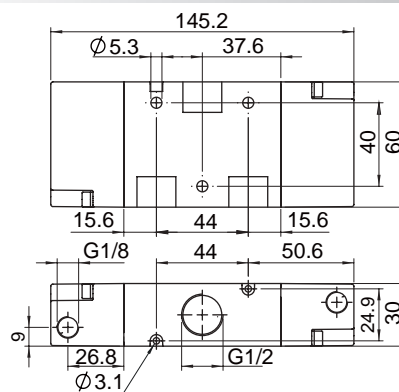

01V P1 3 00 03

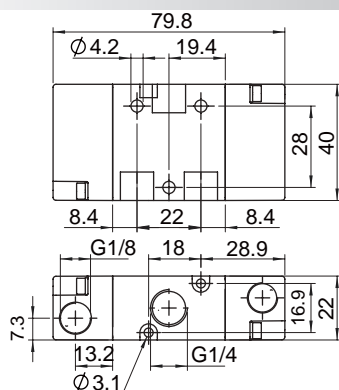

Válvulas de accionamiento Neumático / Pneumatic Valve

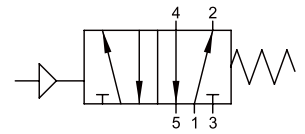

01V PO 5 00 02
 01V PO 5 00 03
 01V PO 5 00 05



5/2 Vías/Ways

MONOESTABLE CON RETORNO POR MUELLE
 MONOSTABLE SPRING RETURN

CÓDIGO CODE	VÍAS WAYS	MEDIDA SIZE
01V PO 5 00 02	5/2	1/8
01V PO 5 00 03	5/2	1/4
01V PO 5 00 05	5/2	1/2

01V PO 5 00 02

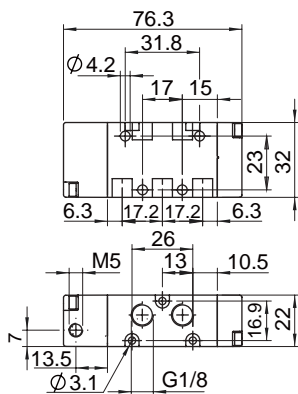

01V PO 5 00 05

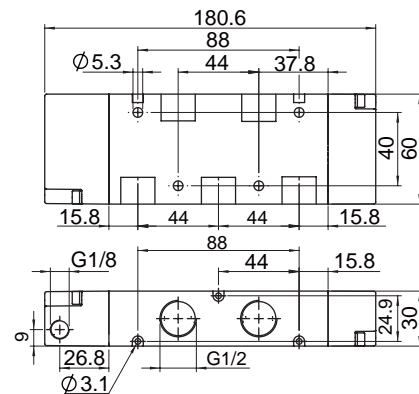

01V PO 5 00 03

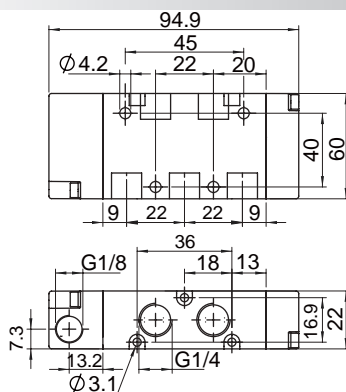

Válvulas de accionamiento Neumático / Pneumatic Valve

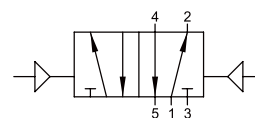

01V P1 5 00 02
01V P1 5 00 03
01V P1 5 00 05



5/2 Vías/Ways

BIESTABLE
TWO STABLE POSITIONS

CÓDIGO CODE	VÍAS WAYS	MEDIDA SIZE
01V P1 5 00 02	5/2	1/8
01V P1 5 00 03	5/2	1/4
01V P1 5 00 05	5/2	1/2

01V P1 5 00 02

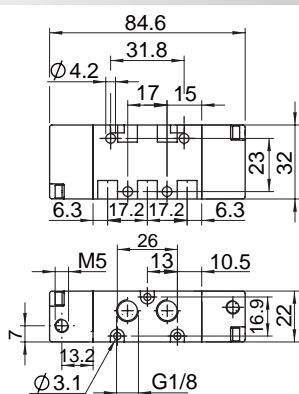

01V P1 5 00 05

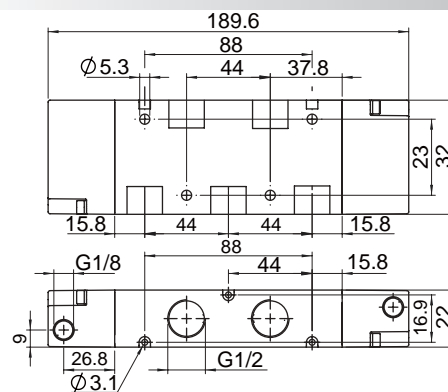

01V P1 5 00 03

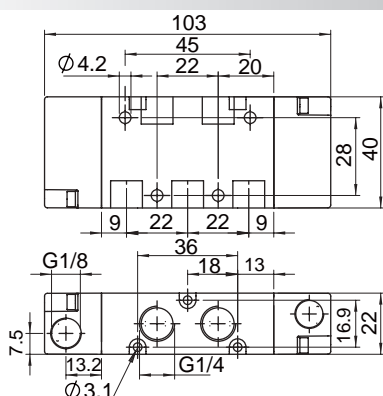

Válvulas de accionamiento Manual / Manual Valve

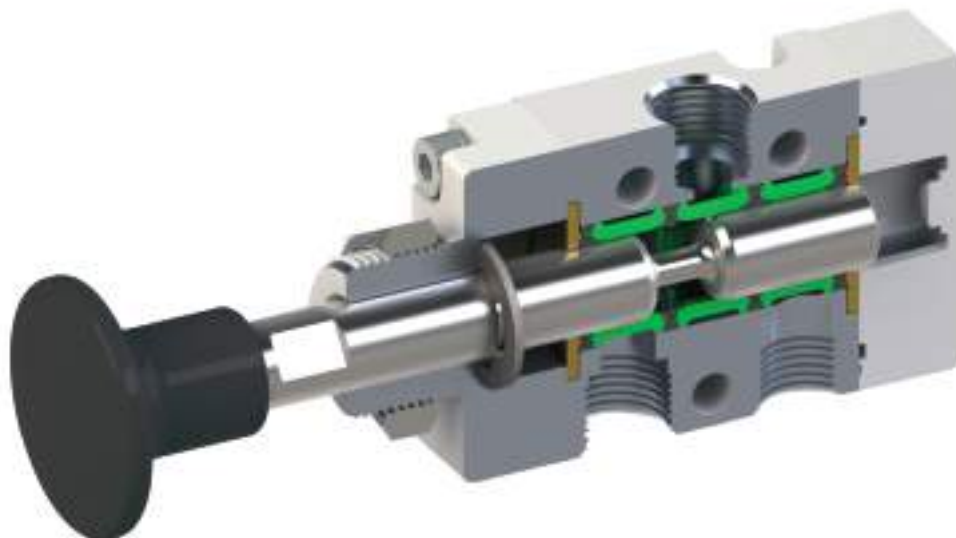

Características Técnicas - Technical Characteristics

ROSCAS / THREADED

CAUDAL A 6 BAR CON Δp 1 bar

6 bar FLOW RATE WITH Δp 1 bar

PRESIÓN DE EJERCICIO / OPERATING PRESSURE

TEMPERATURA / TEMPERATURE

MATERIALES / MATERIAL

1/8

1/8
740 NI/min

1/4

1/4
1200 NI/min

0 - 10 Bar

-10° / +60° C

CUERPO EN ALUMINIO ANODIZADO Y BARNIZADO
ANODISED AND PAINTED ALUMINIUM BODY
CORREDERA EN ACERO INOX NIQUELADO QUÍMICAMENTE
INOX CHEMICAL NICKEL-PLATED SPOOL

JUNTAS EN NBR

NBR SEALS

M16x1

MONTAJE EN PANEL / PANEL MOUNT

Tabla de codificación para pedidos - Article codes to be used for ordering

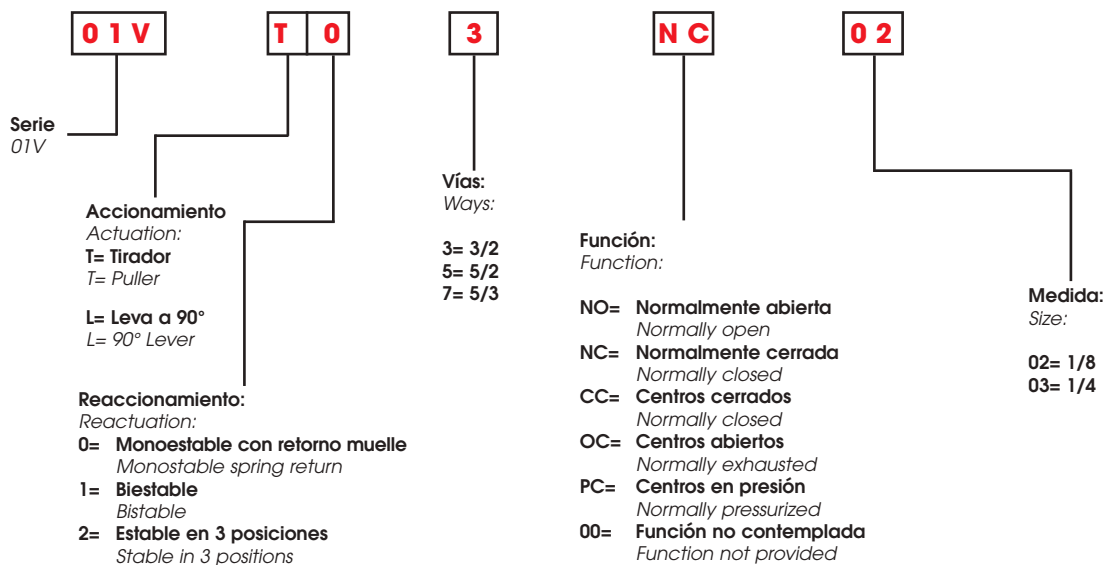

Válvula de Tirador / Puller Valve

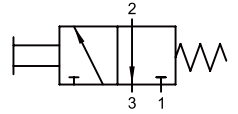

01VT03NC02
01VT03NC03

3/2 Vías/Ways

MONOESTABLE CON RETORNO POR MUELLE
MONOSTABLE SPRING RETURN

CÓDIGO CODE	VÍAS WAYS	FUNCIÓN FUNCTION	MEDIDA SIZE
01V T0 3 NC 02	3/2	NC	1/8
01V T0 3 NC 03	3/2	NC	1/4

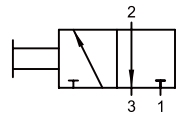

01VT13NC02
01VT13NC03

3/2 Vías/Ways

BIESTABLE
TWO STABLE POSITIONS

CÓDIGO CODE	VÍAS WAYS	MEDIDA SIZE
01V T1 3 00 02	3/2	1/8
01V T1 3 00 03	3/2	1/4

01V T0 3 NC 02 01V T1 3 00 02

01V T0 3 NC 03 01V T1 3 00 03

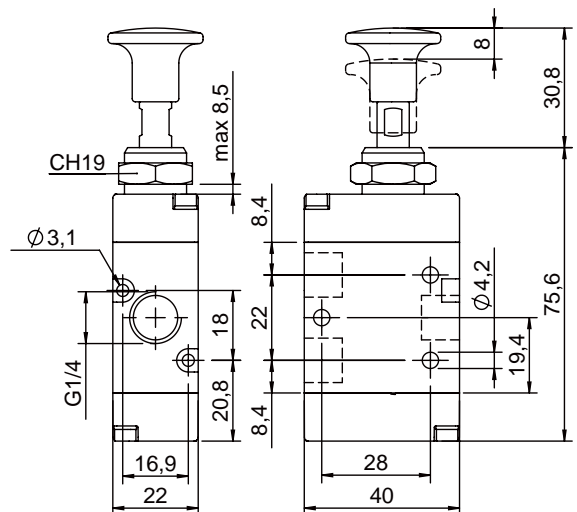
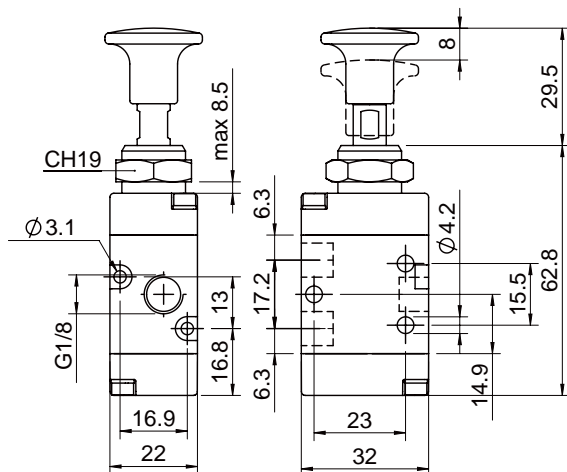

Válvula de Tirador / Puller Valve

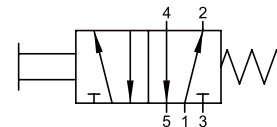

01VT050002
01VT050003

5/2 Vías/Ways

MONOESTABLE CON RETORNO POR MUELLE
MONOSTABLE SPRING RETURN

CÓDIGO CODE	VÍAS WAYS	MEDIDA SIZE
01V TO 5 00 02	5/2	1/8
01V TO 5 00 03	5/2	1/4

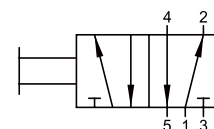

01VT150002
01VT150003

5/2 Vías/Ways

BIESTABLE
TWO STABLE POSITIONS

CÓDIGO CODE	VÍAS WAYS	MEDIDA SIZE
01V T1 5 00 02	5/2	1/8
01V T1 5 00 03	5/2	1/4

01V TO 5 00 02 01V T1 5 00 02

01V TO 5 00 03 01V T1 5 00 03

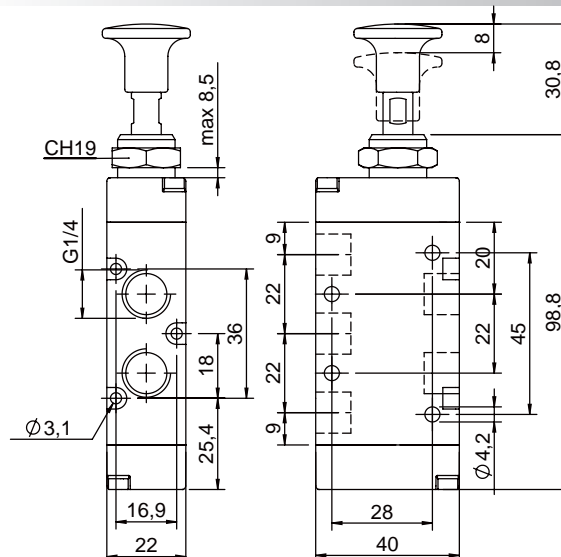
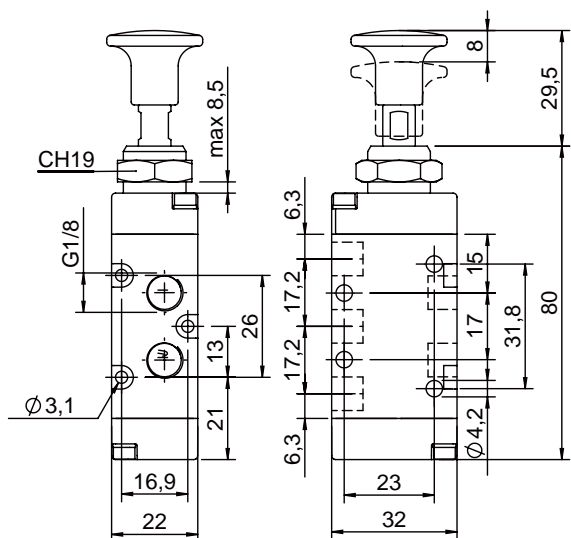

Válvulas de Leva a 90° / 90° Lever Valve

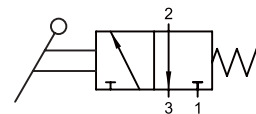

01VL03NC02
01VL03NC03

3/2 Vías/Ways

MONOESTABLE CON RETORNO POR MUELLE
MONOSTABLE SPRING RETURN

CÓDIGO CODE	VÍAS WAYS	FUNCIÓN FUNCTION	MEDIDA SIZE
01V L0 3 NC 02	3/2	NC	1/8
01V L0 3 NC 03	3/2	NC	1/4

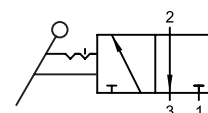

01VL130002
01VL130003

3/2 Vías/Ways

BIESTABLE
TWO STABLE POSITIONS

CÓDIGO CODE	VÍAS WAYS	MEDIDA SIZE
01V L1 3 00 02	3/2	1/8
01V L1 3 00 03	3/2	1/4

01V L0 3 NC 02 01V L1 3 00 02

01V L0 3 NC 03 01V L1 3 00 03

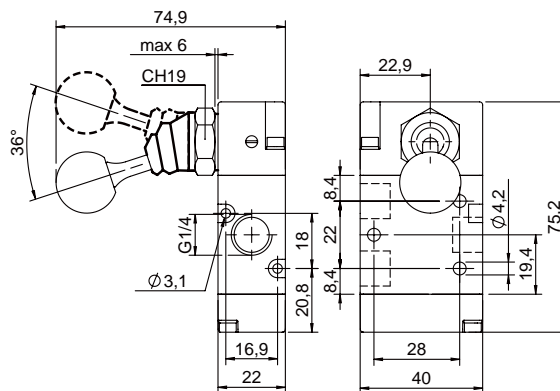
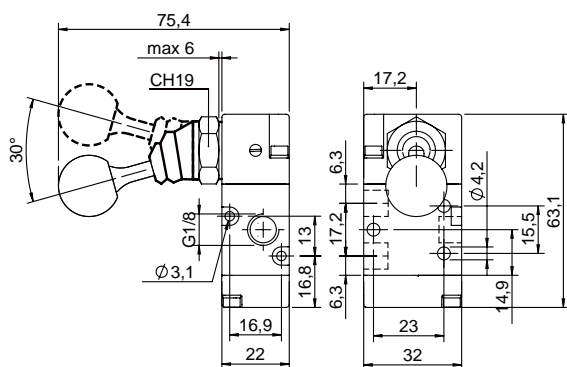

Válvulas de Leva a 90° / 90° Lever Valve

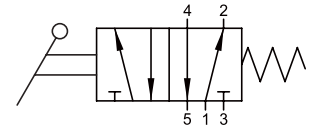

01VL050002
01VL050003

5/2 Vías/Ways

MONOESTABLE CON RETORNO POR MUELLE
MONOSTABLE SPRING RETURN

CÓDIGO CODE	VÍAS WAYS	MEDIDA SIZE
01V L0 5 00 02	5/2	1/8
01V L0 5 00 03	5/2	1/4

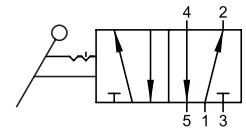

01VL150002
01VL150003

5/2 Vías/Ways

BIESTABLE
TWO STABLE POSITIONS

CÓDIGO CODE	VÍAS WAYS	MEDIDA SIZE
01V L1 5 00 02	5/2	1/8
01V L1 5 00 03	5/2	1/4

01V L0 5 00 02 01V L1 5 00 02

01V L0 5 00 03 01V L1 5 00 03

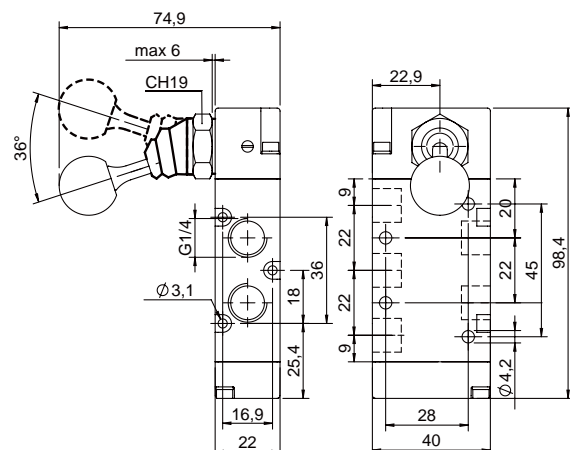
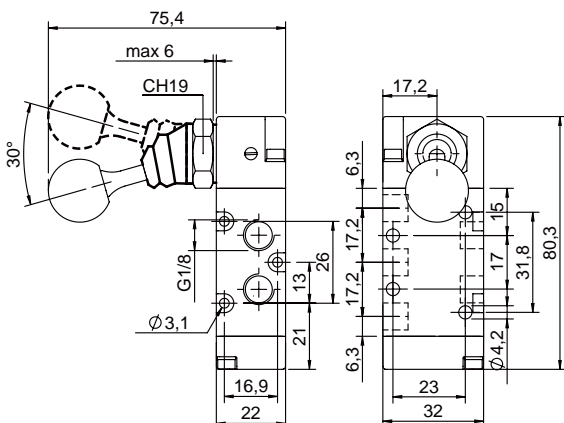

Válvulas de Leva a 90° / 90° Lever Valve

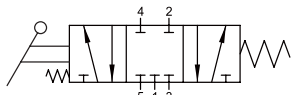

01V L0 7 CC 02
01V L0 7 CC 03

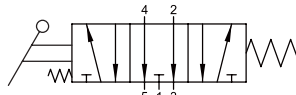

01V L0 7 OC 02
01V L0 7 OC 03

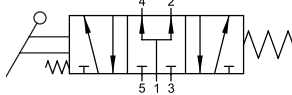

01V L0 7 PC 02
01V L0 7 PC 03

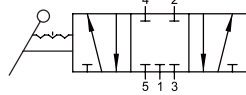

01V L2 7 CC 02
01V L2 7 CC 03



01V L2 7 OC 02
01V L2 7 OC 03

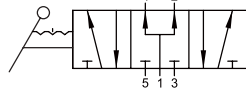

01V L2 7 PC 02
01V L2 7 PC 03



01V L2 7 CC 02 **01V L2 7 OC 02** **01V L2 7 PC 02**

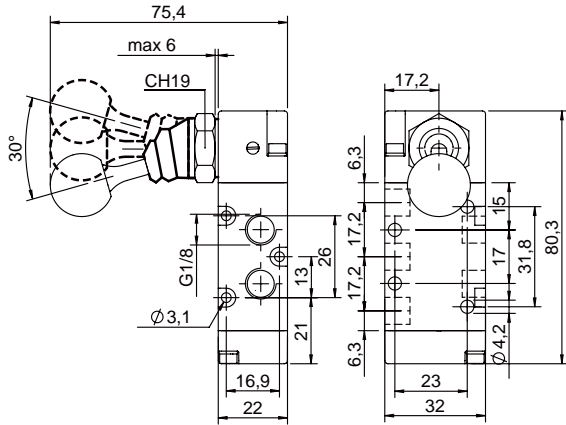

01V L0 7 CC 02 **01V L0 7 OC 02** **01V L0 7 PC 02**

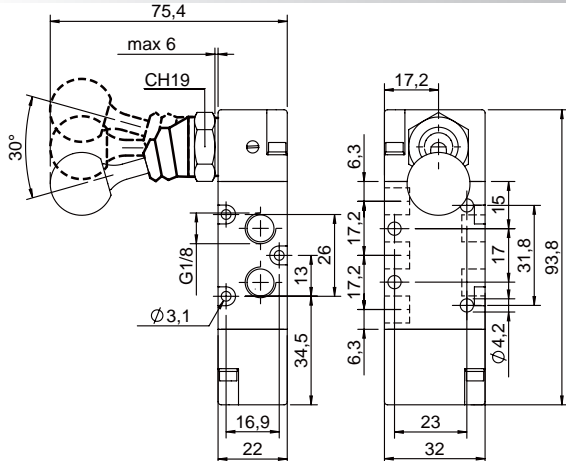

5/3 Vías/Ways

MONOESTABLE CON RETORNO POR MUELLE
MONOSTABLE SPRING RETURN

CÓDIGO CODE	VÍAS WAYS	FUNCIÓN FUNCTION	MEDIDA SIZE
01V L0 7 CC 02	5/3	CC	1/8
01V L0 7 CC 03	5/3	CC	1/4
01V L0 7 OC 02	5/3	OC	1/8
01V L0 7 OC 03	5/3	OC	1/4
01V L0 7 PC 02	5/3	PC	1/8
01V L0 7 PC 03	5/3	PC	1/4

5/3 Vías/Ways

ESTABLE EN 3 POSICIONES / 3 STABLE POSITIONS

CÓDIGO CODE	VÍAS WAYS	FUNCIÓN FUNCTION	MEDIDA SIZE
01V L2 7 CC 02	5/3	CC	1/8
01V L2 7 CC 03	5/3	CC	1/4
01V L2 7 OC 02	5/3	OC	1/8
01V L2 7 OC 03	5/3	OC	1/4
01V L2 7 PC 02	5/3	PC	1/8
01V L2 7 PC 03	5/3	PC	1/4

01V L2 7 CC 03 **01V L2 7 OC 03** **01V L2 7 PC 03**

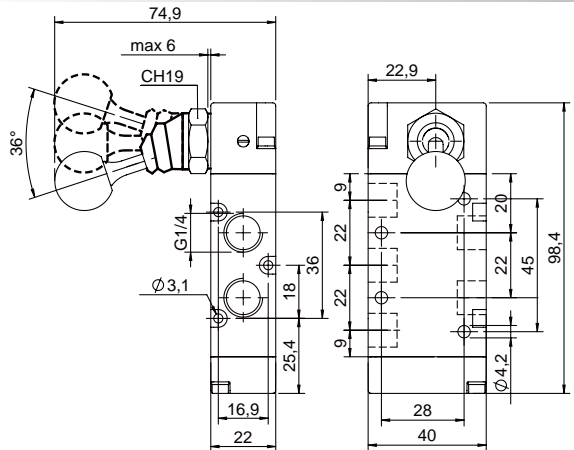

01V L0 7 CC 03 **01V L0 7 OC 03** **01V L0 7 PC 03**

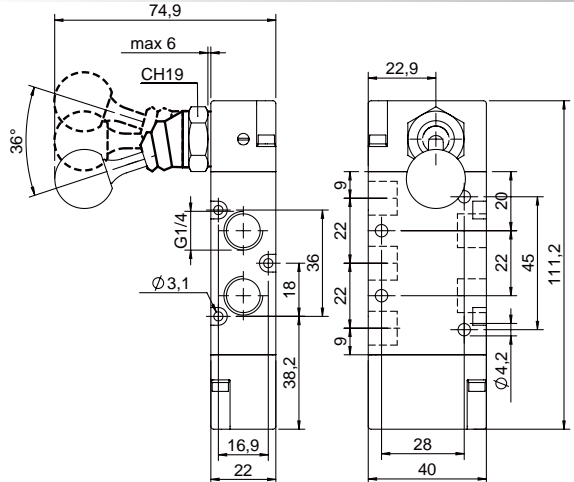

Válvulas de accionamiento mecánico / Mechanically actuated Valve

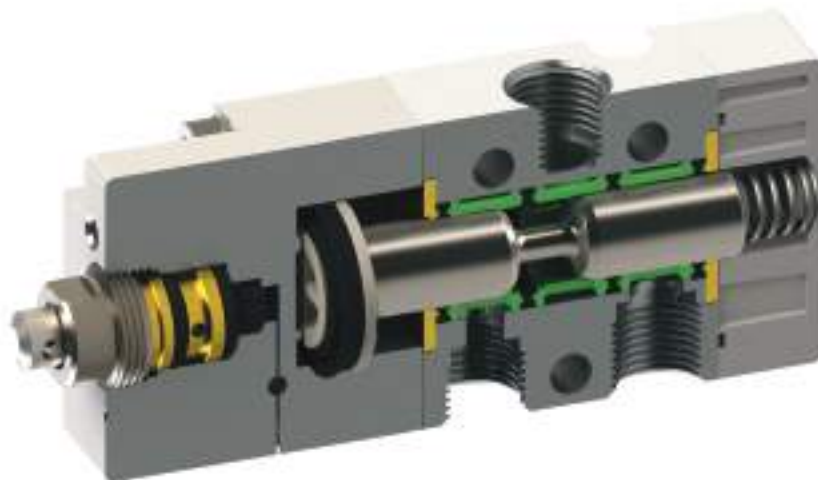

Características Técnicas - Technical Characteristics

ROSCA / THREADED

CAUDAL A 6 BAR CON Δp 1 bar / 6 bar FLOW RATE WITH Δp 1 bar

PRESIÓN DE EJERCICIO / OPERATING PRESSURE

FUERZA DE ACCIONAMIENTO / DRIVING FORCE

TEMPERATURA / TEMPERATURE

MATERIALES / MATERIAL

1/8

1/8

740 NI/min

2 - 10 Bar

5.8 N

-10° / +60° C

CUERPO EN ALUMINIO ANODIZADO Y BARNIZADO
 ANODISED AND PAINTED ALUMINIUM BODY
CORREDERA EN ALUMINIO NIQUELADO QUÍMICAMENTE
 CHEMICAL NICKEL-PLATED SPOOL
JUNTAS EN NBR
 NBR SEALS

Tabla de códigos de pedido - Article codes to be used for ordering

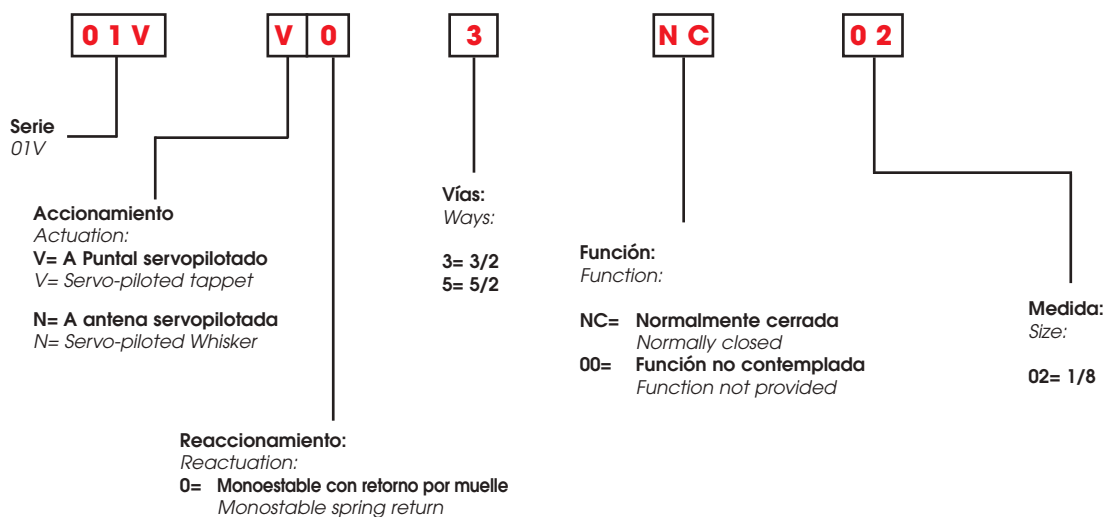

Válvulas a Puntal Servopilotadas / Servo-Piloted Tappet Valves



3/2 Vías/Ways

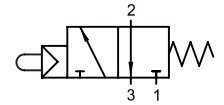

MONOESTABLE CON RETORNO POR MUELLE
MONOSTABLE SPRING RETURN

CÓDIGO CODE	VÍAS WAYS	FUNCIÓN FUNCTION	TAMAÑO SIZE
01V V0 3 NC 02	3/2	NC	1/8



5/2 Vie/Ways

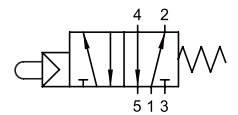

MONOESTABLE CON RETORNO POR MUELLE
MONOSTABLE SPRING RETURN

CÓDIGO CODE	VÍAS WAYS	TAMAÑO SIZE
01V V0 5 00 02	5/2	1/8



04V0100001



04V0600002



04V0600001

Las válvulas servopilotadas están predispuestas para los actuadores de panel. Para la interface, los pulsadores y selectores consultar la serie 04V en la página 15.41
Le valvole servopilotate sono predisposte per gli attuatori da pannello. Per le interfacce, i pulsanti e i selettori consultare la serie 04V a pagina 15.41

01V V0 3 NC 02

01V V0 5 00 02

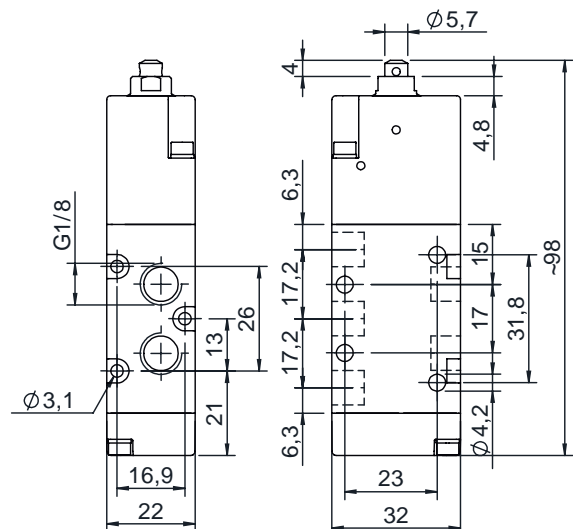
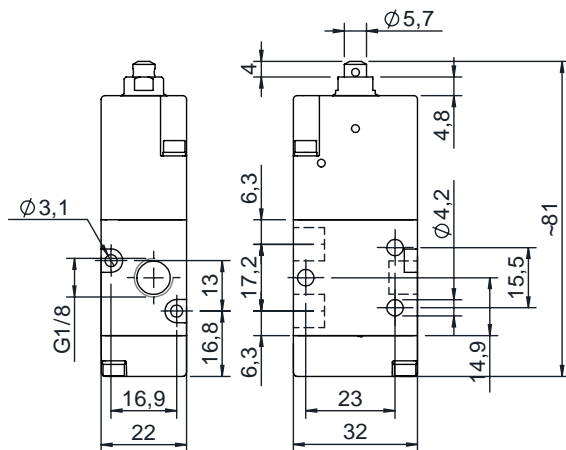

Válvulas de Antena Servopilotadas/ Servo-Piloted whisker valves



3/2 Vie/Ways

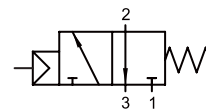

MONOESTABLE CON RETORNO POR MUELLE
MONOSTABLE SPRING RETURN

CÓDIGO CODE	VÍAS WAYS	FUNCIÓN FUNCTION	TAMAÑO SIZE
01V NO 3 NC 02	3/2	NC	1/8



5/2 Vie/Ways

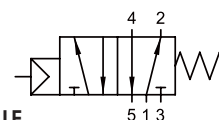

MONOESTABLE CON RETORNO POR MUELLE
MONOSTABLE SPRING RETURN

CÓDIGO CODE	VÍAS WAYS	TAMAÑO SIZE
01V NO 5 00 02	5/2	1/8

01V NO 3 NC 02

01V NO 5 00 02

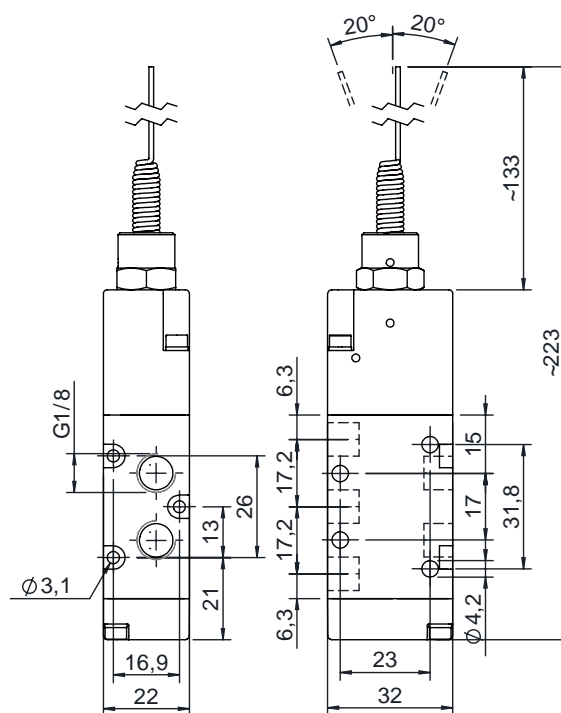
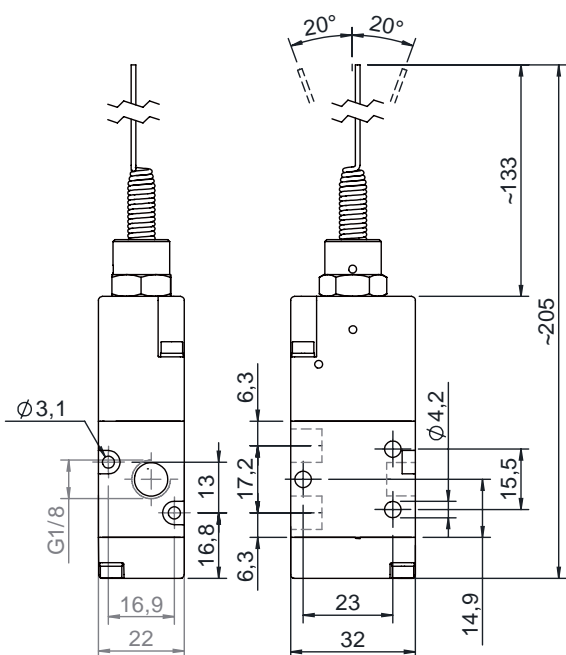

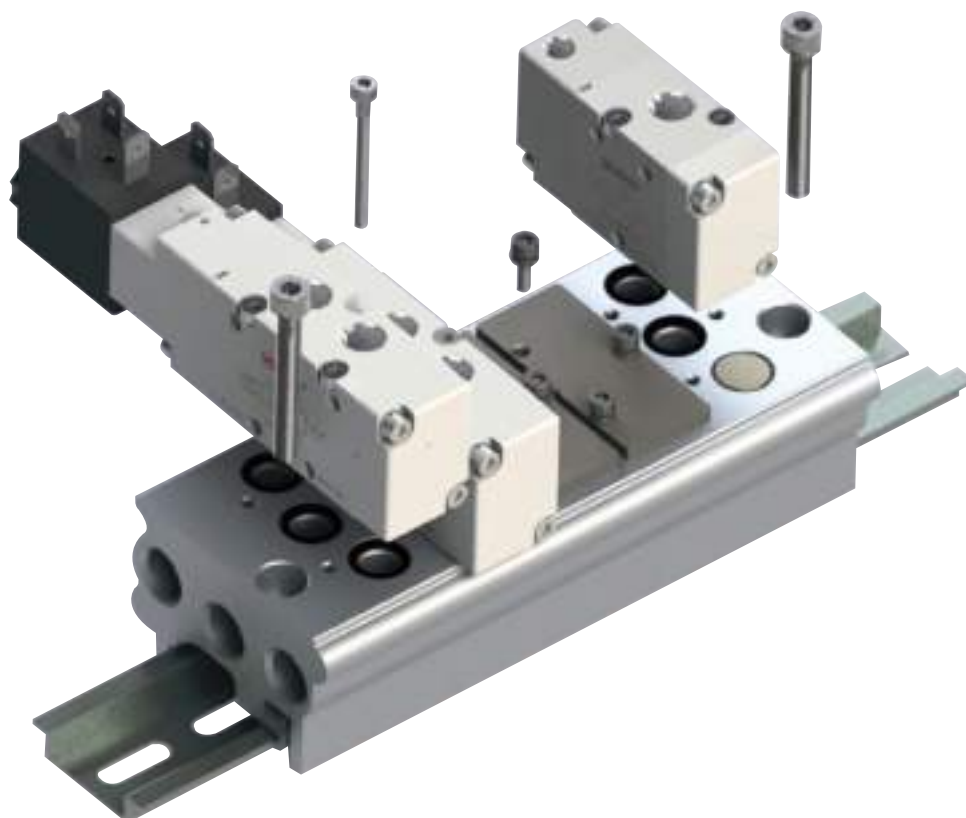
Bases Múltiples / Multiple Bases

Base múltiple 1/8
Manifold plates 1/8

CÓDIGO CODE	VÍAS WAYS	MEDIDA SIZE
01VB000002	2	1/8
01VB000003	3	1/8
01VB000004	4	1/8
01VB000005	5	1/8
01VB000006	6	1/8
01VB000007	7	1/8
01VB000008	8	1/8
01VB000009	9	1/8
01VB000010	10	1/8

Base múltiple 1/4
Manifold plates 1/4

CÓDIGO CODE	VÍAS WAYS	MEDIDA SIZE
01VB010002	2	1/4
01VB010003	3	1/4
01VB010004	4	1/4
01VB010005	5	1/4
01VB010006	6	1/4
01VB010007	7	1/4
01VB010008	8	1/4
01VB010009	9	1/4
01VB010010	10	1/4

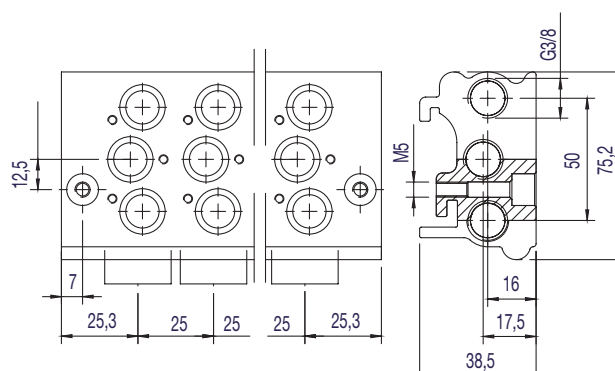
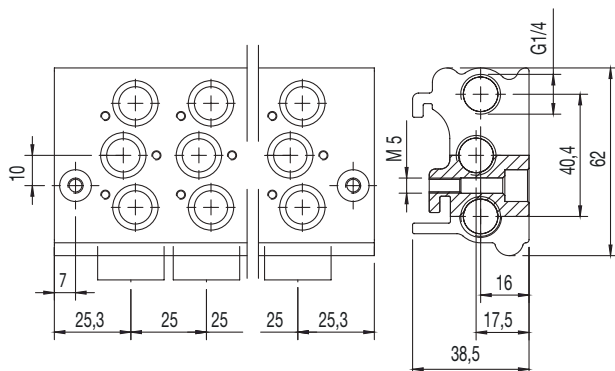
Las bases vienen suministradas con tornillos y tóricas para el montaje
 The bases are supplied with screws and O-Ring for attachment of the valves



Bases Múltiples / Multiple Bases

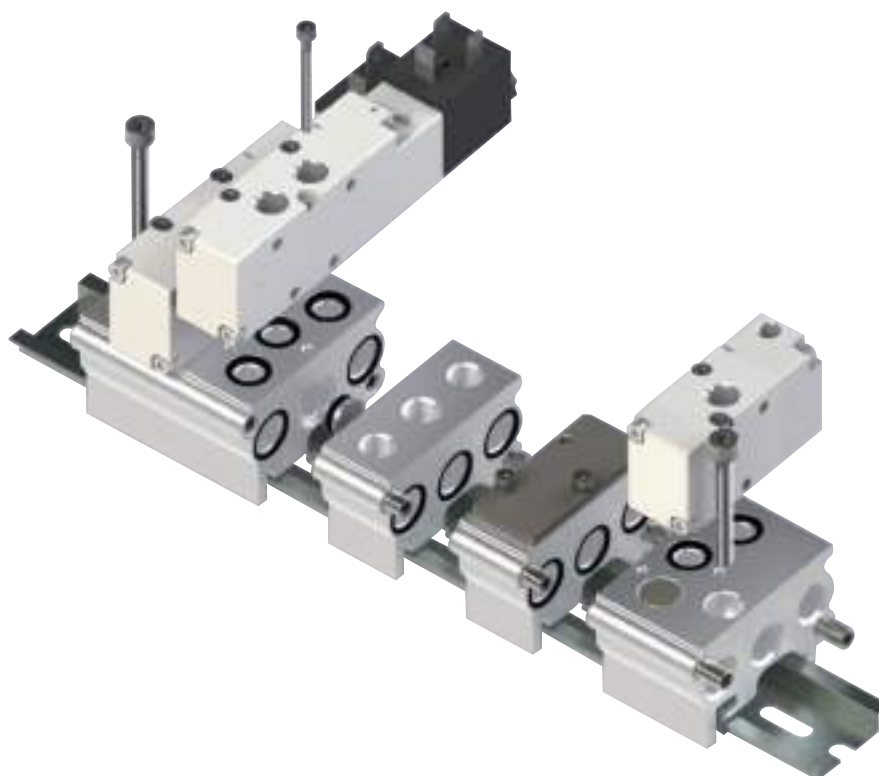

Terminal anterior con base integrada Front terminal-based integrated

CÓDIGO CODE	MEDIDA SIZE
01VB100000	1/8
01VB100001	1/4

El terminal viene completo de tornillos y tóricas para la fijación de las válvulas y la base.
The terminal is supplied with screws and o-rings for fastening and fixing the valve to the base.



Terminal posterior con base integrada Rear terminal-based integrated

CÓDIGO CODE	MEDIDA SIZE
01VB200000	1/8
01VB200001	1/4

El terminal viene completo de tornillos y tóricas para la fijación de las válvulas y la base.
The terminal is supplied with screws and o-rings for fastening and fixing the valve to the base.



Base modular Modular Base

CÓDIGO CODE	MEDIDA SIZE
01VB300000	1/8
01VB300001	1/4

La base viene suministrada completa de tornillos y tóricas para la fijación de los componentes.
The base is supplied with screws and o-rings for attachment between the various components.

Bases Múltiples / Multiple Bases



Alimentación intermedia
Intermediate power

CÓDIGO CODE	MEDIDA SIZE
01VB400000	1/8
01VB400001	1/4

La alimentación viene suministrada completa de tornillos y tóricas para la fijación de los componentes.
Power is supplied with screws and o-rings for attachment between the various components.

01VB100000

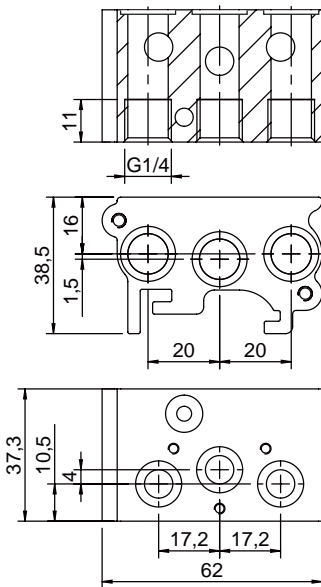

01VB100001

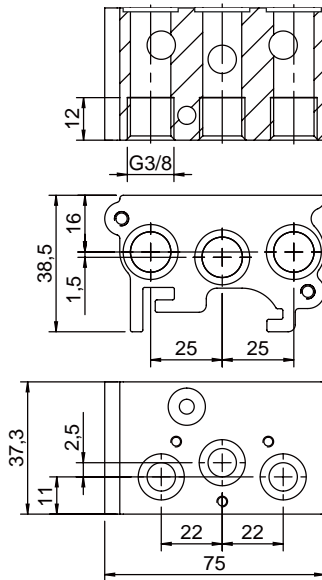

01VB200000

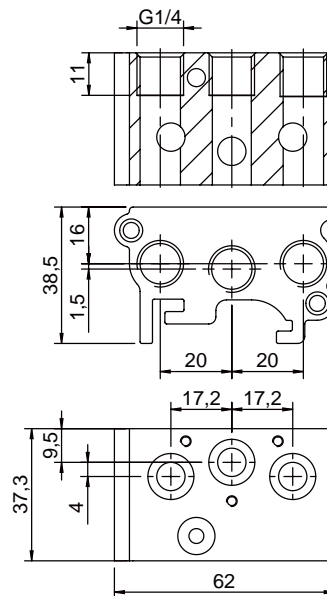

01VB200001

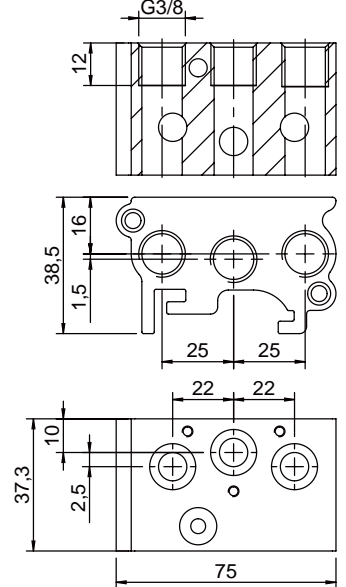

01VB300000

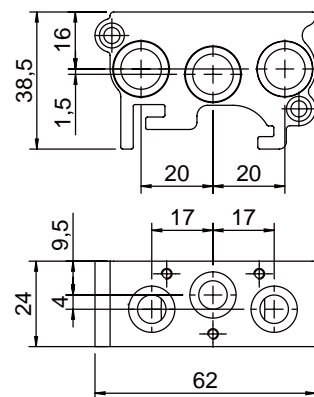

01VB300001

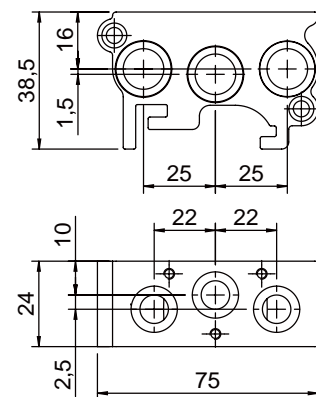

01VB400000

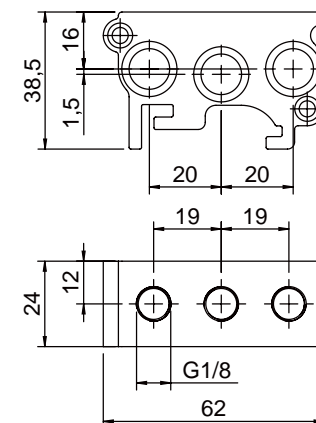

01VB400001

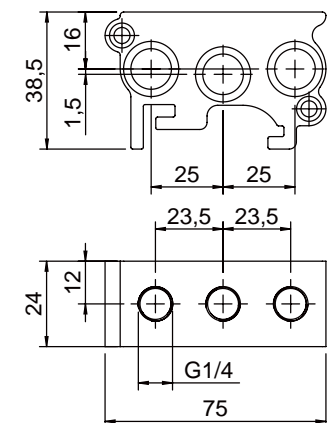

Accesorios para Bases Múltiples / Multiple Bases Accessories

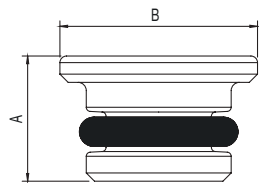

Tapón para conectar válvula 3 vías Plug for 3 way valve connection

CÓDIGO CODE	MEDIDA SIZE	A	B
01VB600000	1/8	7.5	12
01VB600001	1/4	7.5	14



Tapón intermedio para bases modulares Intermediate steps for modular base

CÓDIGO CODE	MEDIDA SIZE	A	B
01VB800000	1/8	7.5	12
01VB800001	1/4	7.5	14

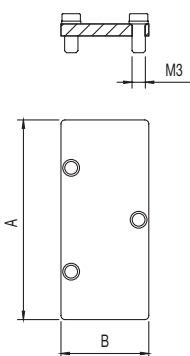

Placa de cierre Cover Plate

CÓDIGO CODE	MEDIDA SIZE	A	B
01VB900000	1/8	50	22
01VB900001	1/4	62	22

La placa viene suministrada completa de tornillos para la fijación sobre la base.

The Cover Plate is supplied with screws for securing the Base.

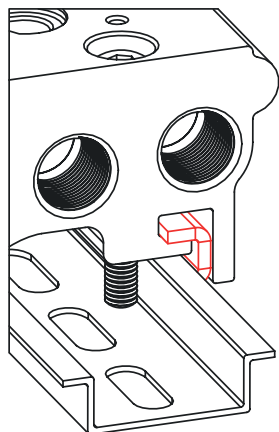
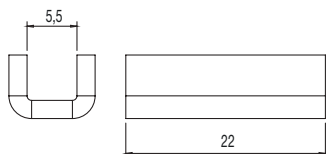

Soporte de fijación con barra Omega Bracket with Omega bar

CÓDIGO CODE	MEDIDA SIZE
01VB700000	1/8 - 1/4

Características Técnicas - Technical Characteristics

TIPO DE FIJACIÓN TYPE OF MOUNTING	TORNILLOS SCREW
CON BARRA OMEGA EN50222 DI ESPESOR 15MM WITH EN50222 OMEGA BAR THICKNESS 15MM	TORNILLO M5 x 40 SCREW M5 x 40
CON BARRA OMEGA EN50222 DI ESPESOR 7.5MM WITH EN50222 OMEGA BAR THICKNESS 7.5MM	TORNILLO M5 x 35 SCREW M5 x 35
DIRECTO A LA BASE DIRECT ON BASE	TORNILLO M4 x 40 SCREW M4 x 40



Serie 02V

MICROVÁLVULAS
MICROVALVE

MicroVálvulas / MicroValve



Características Técnicas - Technical Characteristics

ROSCAS / THREADED

CAUDAL A 6 BAR CON Δp 1 bar

6 bar FLOW RATE WITH Δp 1 bar

PRESIÓN DE EJERCICIO / OPERATING PRESSURE

TEMPERATURA / TEMPERATURE

MATERIALES / MATERIAL

FUERZA DE ACCIONAMIENTO / ACTUATING FORCE

M5

M5

100 NI/min

2 - 10 Bar

-10° / +60° C

CUERPO EN ALUMINIO ANODIZADO

ANODISED ALUMINIUM BODY

MUELLE EN ACERO INOX

STAINLESS STEEL SPRING

JUNTAS EN NBR

NBR SEALS

6 N

Tabla de codificación para pedidos - Article codes to be used for ordering

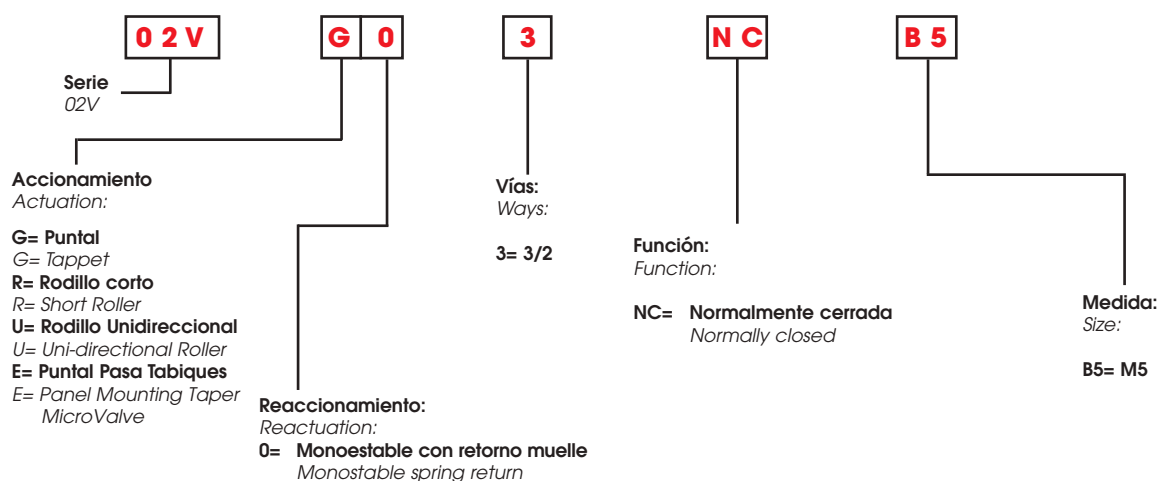

MicroVálvulas / MicroValve



3/2 Vías/Ways

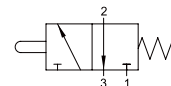

MICROVÁLVULA DE PUNTAL
TAPPET MICROVALVE

CÓDIGO CODE	VÍAS WAYS	FUNCIÓN FUNCTION	MEDIDA SIZE
02V G0 3 NC B5	3/2	NC	M5



3/2 Vías/Ways

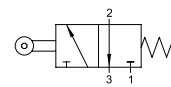

MICROVÁLVULA DE RODILLO CORTO
SHORT ROLLER MICROVALVE

CÓDIGO CODE	VÍAS WAYS	FUNCIÓN FUNCTION	MEDIDA SIZE
02V R0 3 NC B5	3/2	NC	M5



3/2 Vías/Ways

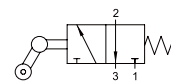

MICROVÁLVULA DE RODILLO UNIDIRECCIONAL
UNI-DIRECTIONAL ROLLER MICROVALVE

CÓDIGO CODE	VÍAS WAYS	FUNCIÓN FUNCTION	MEDIDA SIZE
02V U0 3 NC B5	3/2	NC	M5



3/2 Vías/Ways

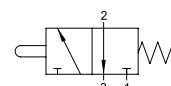

MICROVÁLVULA DE PUNTAL PASATABIQUES
PANEL MOUNTING TAPPET MICROVALVE

CÓDIGO CODE	VÍAS WAYS	FUNCIÓN FUNCTION	MEDIDA SIZE
02V E0 3 NC B5	3/2	NC	M5

02V G0 3 NC B5

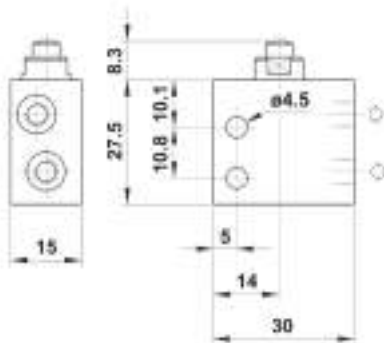

02V R0 3 NC B5

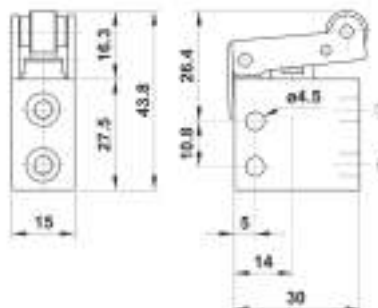

02V U0 3 NC B5

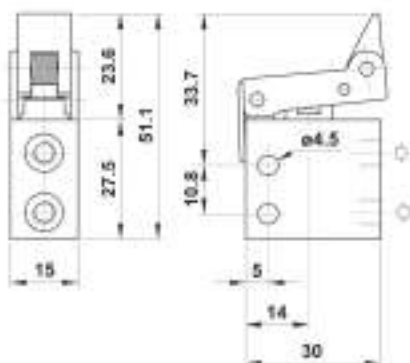

02V E0 3 NC B5

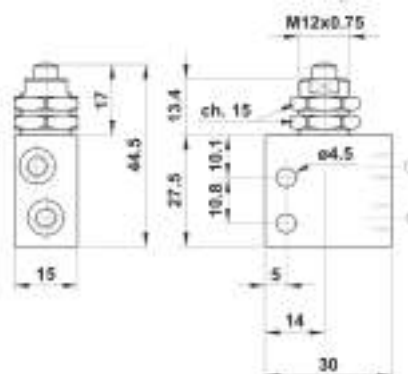



Serie 03V

VÁLVULAS 16 MM DE ACCIONAMIENTO MECÁNICO Y MANUAL
16 mm Valve with mechanical and manual drive

Válvulas 16 mm / 16 mm Valve



Características Técnicas - Technical Characteristics

ROSCAS / THREADED

CAUDAL A 6 BAR CON Δp 1 bar

6 bar FLOW RATE WITH Δp 1 bar

PRESIÓN DE EJERCICIO / OPERATING PRESSURE

TEMPERATURA / TEMPERATURE

MATERIALES / MATERIAL

1/8

1/8

350 NI/min

2 - 10 Bar

-10° / +60° C

CUERPO EN ALUMINIO ANODIZADO
ANODISED AND ALUMINIUM BODY

MUELLE EN ACERO INOX

STAINLESS STEEL SPRING

JUNTAS EN NBR

NBR SEALS

Tabla de codificación para pedidos - Article codes to be used for ordering

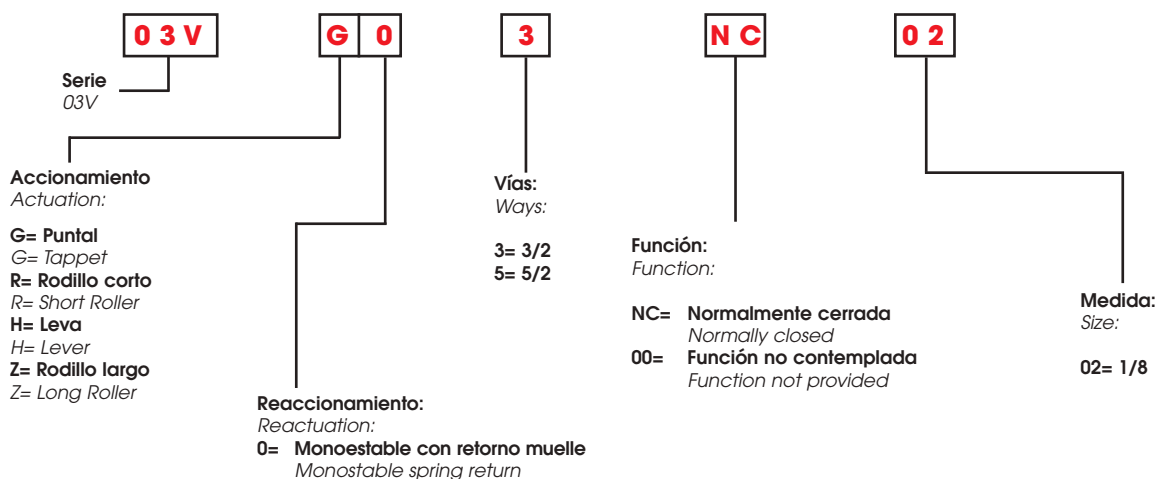

Válvulas 16 mm / 16 mm Valve



3/2 Vías/Ways

VÁLVULA DE PUNTA - RITORNO A MOLLA
TAPPET - SPRING RETURN VALVE

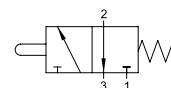

CÓDIGO CODE	VÍAS WAYS	FUNCIÓN FUNCTION	MEDIDA SIZE	FUERZA ACCIONAMIENTO DRIVING FORCE
03V G0 3 NC 02	3/2	NC	1/8	19.6 N

5/2 Vías/Ways

VÁLVULA DE PUNTA - RITORNO A MOLLA
TAPPET - SPRING RETURN VALVE

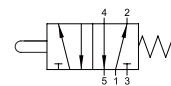

CÓDIGO CODE	VÍAS WAYS	MEDIDA SIZE	FUERZA ACCIONAMIENTO DRIVING FORCE
03V G0 5 00 02	5/2	1/8	39.2 N

3/2 Vías/Ways

VÁLVULA DE RODILLO CORTO - RITORNO A MOLLA
SHORT ROLLER - SPRING RETURN VALVE

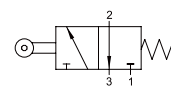

CÓDIGO CODE	VÍAS WAYS	FUNCIÓN FUNCTION	MEDIDA SIZE	FUERZA ACCIONAMIENTO DRIVING FORCE
03V R0 3 NC 02	3/2	NC	1/8	9.8 N

5/2 Vías/Ways

VÁLVULA DE RODILLO CORTO - RITORNO A MOLLA
SHORT ROLLER - SPRING RETURN VALVE

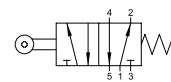

CÓDIGO CODE	VÍAS WAYS	MEDIDA SIZE	FUERZA ACCIONAMIENTO DRIVING FORCE
03V R0 5 00 02	5/2	1/8	21.5 N

03V G0 3 NC 02

03V R0 3 NC 02

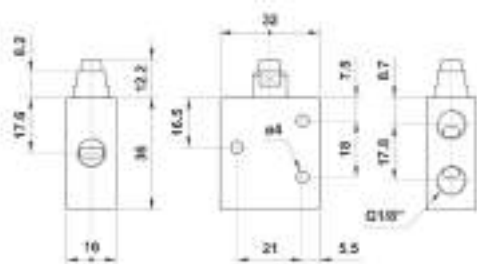

03V G0 5 NC 02

03V R0 5 00 02

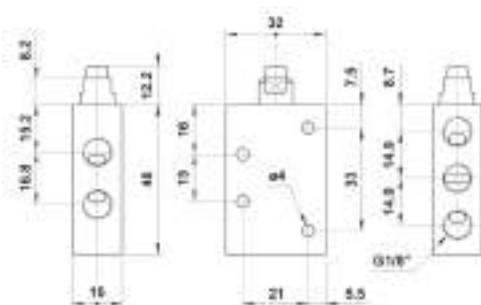

Válvulas 16 mm / 16 mm Valve



3/2 Vías/Ways

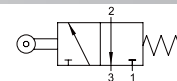

VÁLVULA DE RODILO LARGO - MUELLE MECÁNICO
LONG ROLLER - SPRING RETURN VALVE

CÓDIGO CODE	VÍAS WAYS	FUNCIÓN FUNCTION	MEDIDA SIZE	FUERZA ACCIONAMIENTO DRIVING FORCE
03V Z0 3 NC 02	3/2	NC	1/8	8.3 N

5/2 Vías/Ways

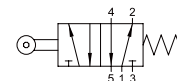

VÁLVULA DE RODILLO LARGO - MUELLE MECÁNICO
LONG ROLLER - SPRING RETURN VALVE

CÓDIGO CODE	VÍAS WAYS	MEDIDA SIZE	FUERZA ACCIONAMIENTO DRIVING FORCE
03V Z0 5 00 02	5/2	1/8	14.2 N

3/2 Vías/Ways

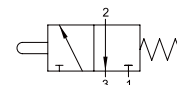

VÁLVULA DE PULSADOR ROJO - MUELLE MECÁNICO
PUSH RED BUTTON - SPRING RETURN VALVE

CÓDIGO CODE	VÍAS WAYS	FUNCIÓN FUNCTION	MEDIDA SIZE	FUERZA ACCIONAMIENTO DRIVING FORCE
03V H0 3 NC 02	3/2	NC	1/8	7.8 N

5/2 Vías/Ways



VÁLVULA DE PULSADOR ROJO - MUELLE MECÁNICO
PUSH RED BUTTON - SPRING RETURN VALVE

CÓDIGO CODE	VÍAS WAYS	MEDIDA SIZE	FUERZA ACCIONAMIENTO DRIVING FORCE
03V H0 5 00 02	5/2	1/8	13.7 N

03V Z0 3 NC 02

03V H0 3 NC 02

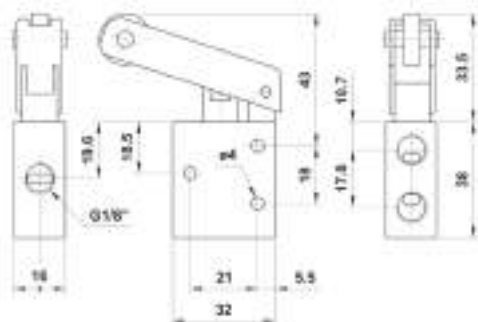

03V Z0 5 00 02

03V H0 5 00 02

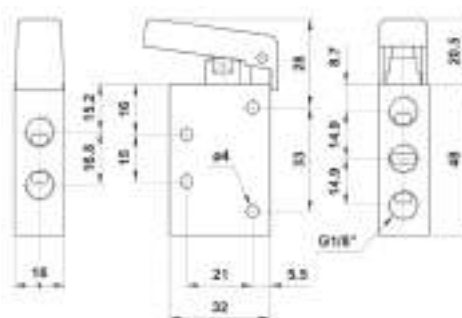
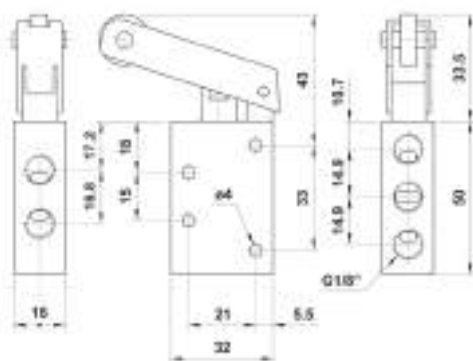



Serie 04V

Válvulas de Panel, Pulsadores y Selectores
Panel Valve, Push Buttons and Selectors

MicroVálvulas / MicroValve

3/2 Vías/Ways

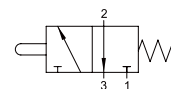

MICROVÁLVULA DE PUNTAL
TAPPET MICROVALVE

CÓDIGO CODE	VÍAS WAYS	FUNCIÓN FUNCTION	MEDIDA SIZE
02V G0 3 NC B5	3/2	NC	M5

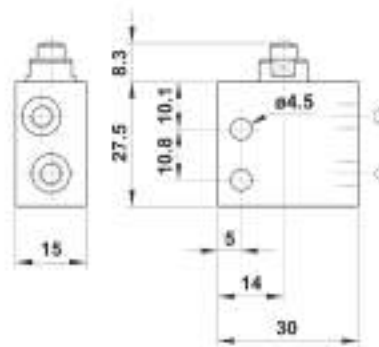

3/2 Vías/Ways

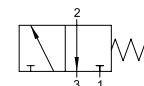

MICROVÁLVULA PARA ACTUADORES DE PANEL
MICROVALVE FOR PANEL MOUNTING ACTUATOR

CÓDIGO CODE	VÍAS WAYS	FUNCIÓN FUNCTION	MEDIDA SIZE
02V D0 3 NC B5	3/2	NC	M5

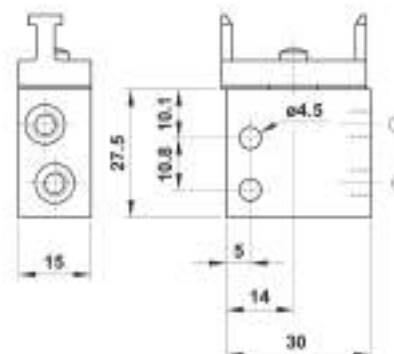

04V060002

04V060001

Interface para conexión pulsador

Interface for connection button

CÓDIGO CODE	
04V060001	INDIVIDUAL / SINGLE
04V060002	DOBLE / DOUBLE

Pulsadores y Selectores / Push Button and Selector

Pulsador con protección/ Protected push button



CÓDIGO CODE	COLORES STANDARD STANDARD COLOR
04V0100001	Rojo / Red - Negro / Black - Blanco / White



CÓDIGO CODE	COLORES COLOR
* 04V01P00VE	Verde / Green
* 04V01P00GI	Amarillo / Yellow
* 04V01P00AZ	Azul / Light Blue

* Los siguientes colores estan disponibles añadiéndolos al kit standard.
The following colors can be ordered separately.

Seta monoestable axial / Axial mono-stable mushroom



CÓDIGO CODE	COLOR COLOR
04V0200N1	Negro / Black
04V0200R1	Rojo / Red

Seta seguridad desbloqueo a rotación / Turn to unlock mushroom



CÓDIGO CODE	COLOR COLOR
04V0200R2	Rojo / Red

TALADRO PARA MONTAJE A PANEL CON DISPOSITIVO ANTIROTAÇÃO.
PANEL MOUNTING HOLE WITH ANTIROTATION FEATURE.

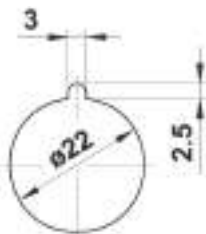

Selector de Llave / Key selector

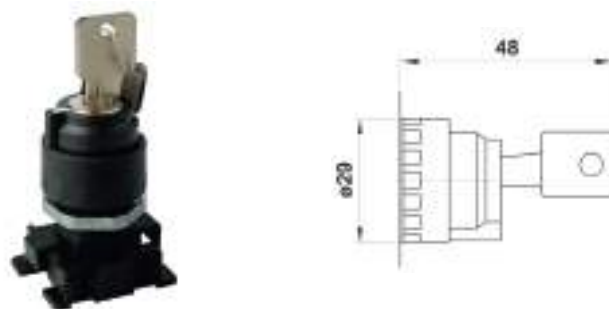

CÓDIGO CODE	COLOR COLOR	FUNCIÓN FUNCTION	POSICIÓN EXTRACCIÓN LLAVE POSITION TO PULL THE KEY OUT
04V0300001	Negro / Black	0 - 1	sólo central / only in central position
04V0300002	Negro / Black	0 - 1	ambas posiciones / both position
04V0300003	Negro / Black	2 - 0 - 1	sólo central / only in central position

Selector de leva corta / Short lever selector



CÓDIGO CODE	COLOR COLOR	FUNCIÓN FUNCTION
04V0400N1	Negro / Black	0 1
04V0400N2	Negro / Black	0 ← 1
04V0400N3	Negro / Black	2 0 1
04V0400N4	Negro / Black	2 → 0 ← 1

Selector de leva larga / Long lever selector



CÓDIGO CODE	COLOR COLOR	FUNCIÓN FUNCTION
04V0500N1	Negro / Black	0 1
04V0500N2	Negro / Black	0 ← 1
04V0500N3	Negro / Black	2 0 1
04V0500N4	Negro / Black	2 → 0 ← 1



Serie 05V

VÁLVULAS 18 MM VDMA
VDMA 18 mm Valve

Válvulas VDMA 18 mm de accionamiento Electroneumático / Solenoid Pilot Valve 18 mm VDMA

Características Técnicas - Technical Characteristics
NORMATIVA DE REFERENCIA / REFERENCE STANDARD
CAUDAL A 6 BAR CON Δp 1 bar
6 bar FLOW RATE WITH Δp 1 bar
PRESIÓN DE EJERCICIO / OPERATING PRESSURE
TEMPERATURA / TEMPERATURE
MATERIALES / MATERIAL
TENSIÓN BOBINA / SOLENOID VOLTAGE
POTENCIA MÍNIMA / MINIMUM POWER
COMANDO MANUAL/ MANUAL CONTROL
VDMA 24563 TALLA 02 (18 mm) / VDMA 24563 TAGLIA 02 (18 mm)
 550 NI/Min

MONOESTABLE / MONOSTABLE: 2.5 - 10 Bar
BIESTABLE / BIESTABLE: 1 - 10 Bar

-10° / +60° C

CUERPO EN ALUMINIO ANODIZADO
ANODISED ALUMINIUM BODY
CORREDERA EN ALUMINIO NIQUELADO
NICKEL-PLATED SPOOL
JUNTAS EN NBR
NBR SEALS

24V DC - 24V AC

2W - 3VA

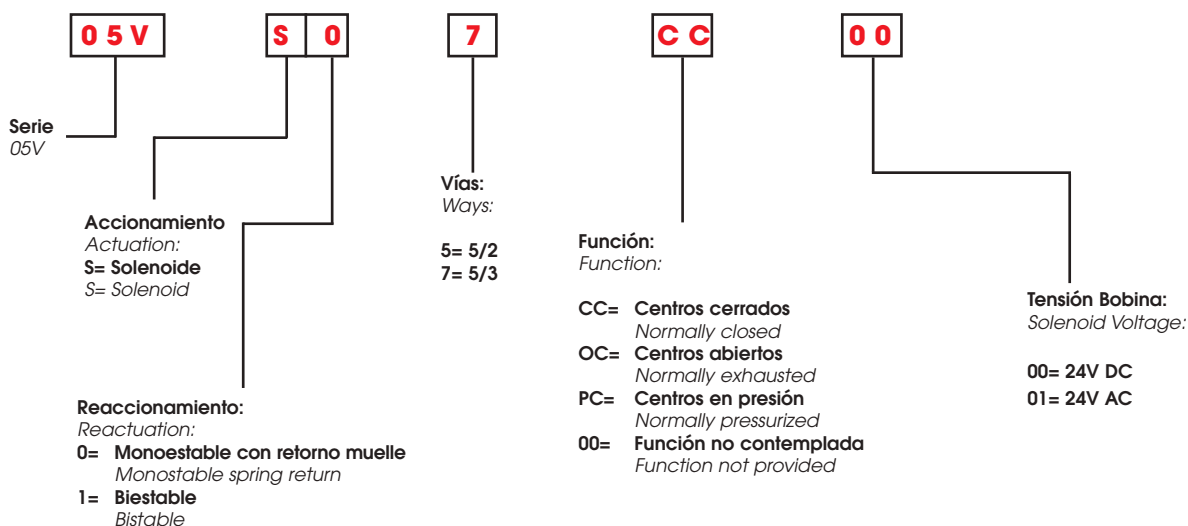
MONOESTABLE / MONOSTABLE
Tabla de codificación para pedidos - Article codes to be used for ordering

Válvulas VDMA 18 mm de accionamiento Electroneumático / Solenoid Pilot Valve 18 mm VDMA



5/2 Vías/Ways

MONOESTABLE CON RETORNO POR MUELLE
MONOSTABLE SPRING RETURN

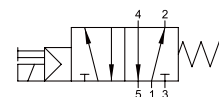

CÓDIGO CODE	VÍAS WAYS	BOBINA SOLENOID
05V S0 5 00 00	5/2	24V DC
05V S0 5 00 01	5/2	24V 50/60Hz



5/2 Vías/Ways

BIESTABLE
TWO STABLE POSITIONS

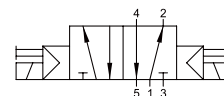

CÓDIGO CODE	VÍAS WAYS	BOBINA SOLENOID
05V S1 5 00 00	5/2	24V DC
05V S1 5 00 01	5/2	24V 50/60Hz



5/3 Vías/Ways

MONOESTABLE CON RETORNO POR MUELLE
MONOSTABLE SPRING RETURN



05VS07CC00
05VS07CC01

05VS07OC00
05VS07OC01

CÓDIGO CODE	VÍAS WAYS	FUNCIÓN FUNCTION	BOBINA SOLENOID
05V S0 7 CC 00	5/3	CC	24V DC
05V S0 7 OC 00	5/3	OC	24V DC
05V S0 7 CC 01	5/3	CC	24V 50/60Hz
05V S0 7 OC 01	5/3	OC	24V 50/60Hz

05V S0 5 00 00 05V S0 5 00 01

05V S0 7 CC 00 05V S0 7 OC 00 05V S0 7 CC 01 05V S0 7 OC 01

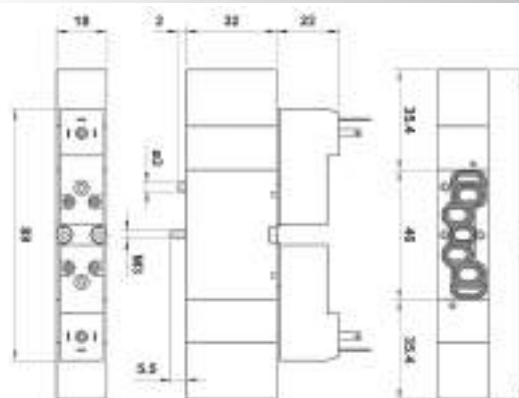

05V S1 5 00 00 05V S1 5 00 01



Conectores/ Connectors

Conectores Connectors

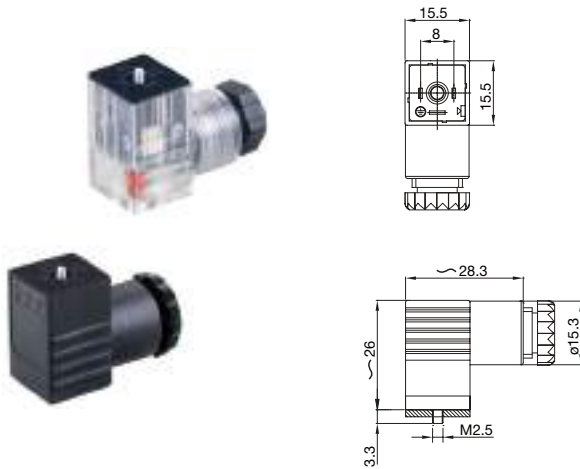

CÓDIGO CODE	COLORES COLOR	CARACTERÍSTICAS CHARACTERISTICS
CON1100001	NEGRO / BLACK	STANDARD A 2 POLOS (2 PIN)
CON1202400	TRANSPARENTE / TRANSPARENT	LED + VDR 0 - 24V

VDR: Dotados de Varistor como dispositivo de protección a sobretensiones.
Fitted with varistors as surge protection device.

ESQUEMA ELÉCTRICO/ WIRING

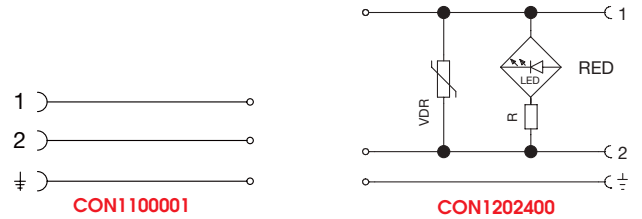

Características Técnicas - Technical Characteristics

GRADO DE PROTECCIÓN / DEGREE OF PROTECTION

JUNTA / GASKET

TERMINALES / TERMINALS

DIÁMETRO DEL CABLE / CABLE DIAMETER

IP67 IEC 60529

JUNTA PLANA / FLAT GASKET

DIN 4365 C

4 ÷ 6 mm

Válvulas VDMA 18 mm de accionamiento Neumático / Pneumatic Valve 18 mm VDMA



Características Técnicas - Technical Characteristics

NORMATIVA DE REFERENCIA / REFERENCE STANDARD

CAUDAL A 6 BAR CON Δp 1 bar

6 bar FLOW RATE WITH Δp 1 bar

PRESIÓN DE EJERCICIO / OPERATING PRESSURE

PRESIÓN DE ACCIONAMIENTO / PRESSURE DRIVE

TEMPERATURA / TEMPERATURE

MATERIALES / MATERIAL

VDMA 24563 TALLA 02 (18 mm) / VDMA 24563 TAGLIA 02 (18 mm)

550 NI/Min

0 - 10 Bar

MONOESTABLE / MONOSTABLE: 2 - 10 Bar

BIESTABLE / BIESTABLE: 1 - 10 Bar

-10° / +60° C

CUERPO EN ALUMINIO ANODIZADO

ANODISED ALUMINIUM BODY

CORREDERA EN ALUMINIO NIQUELADO

NICKEL-PLATED SPOOL

JUNTAS EN NBR

NBR SEALS

Tabla de codificación para pedidos - Article codes to be used for ordering

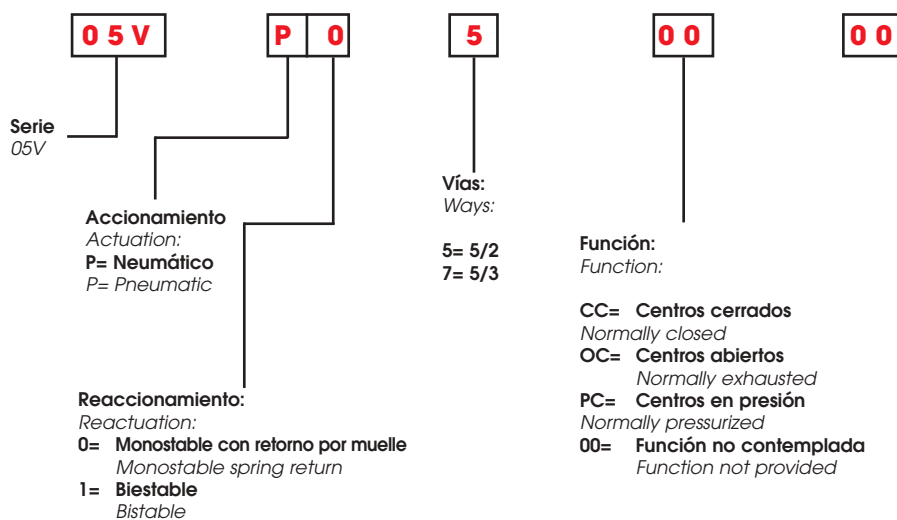

Válvulas VDMA 18 mm de accionamiento Neumático / Pneumatic Valve 18 mm VDMA



5/2 Vías/Ways

MONOESTABLE CON RETORNO POR MUELLE
MONOSTABLE SPRING RETURN

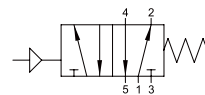

CÓDIGO CODE	VÍAS WAYS
05V P0 5 00 00	5/2



5/2 Vías/Ways

BIESTABLE
TWO STABLE POSITIONS

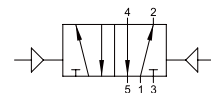

CÓDIGO CODE	VÍAS WAYS
05V P1 5 00 00	5/2

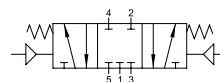

05VP07CC00



05VP07OC00

5/3 Vías/Ways

MONOESTABLE CON RETORNO POR MUELLE
MONOSTABLE SPRING RETURN

CÓDIGO CODE	VÍAS WAYS	FUNCIÓN FUNCTION
05V P0 7 CC 00	5/3	CC
05V P0 7 OC 00	5/3	OC

05V P0 5 00 00

05V P0 7 CC 00 05V P0 7 OC 00

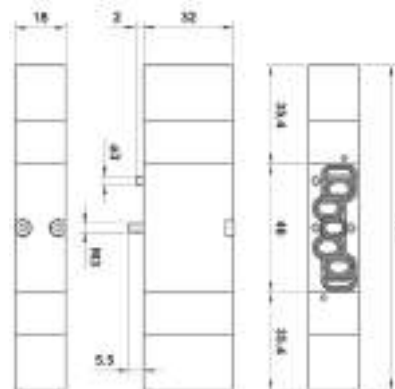
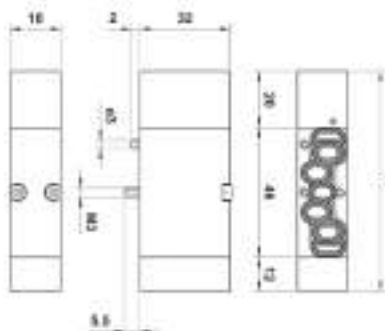

05V P1 5 00 00

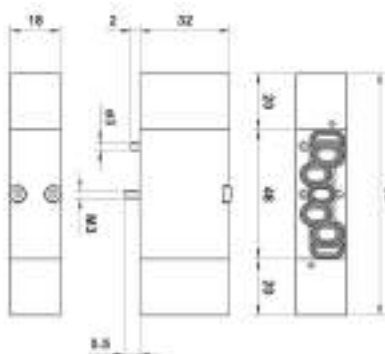

Bases Múltiples y Accesorios / Multiple Bases and Accessories



Terminal anterior con base integrada Front terminal-based integrated

CÓDIGO
CODE

05VB100000

El terminal viene completo de tornillos y tóricas para la fijación de las válvulas y la base.
The base is supplied with screws and gasket for fastening and fixing the valve to the base.



Terminal posterior con base integrada Rear terminal-based integrated

CÓDIGO
CODE

05VB200000

El terminal viene completo de tornillos y tóricas para la fijación de las válvulas y la base.
The base is supplied with screws and gasket for fastening and fixing the valve to the base.



Base modulare Modular Base

CÓDIGO
CODE

05VB300000

La base viene completa de tornillos y tóricas para la fijación de las válvulas a la base.
The base is supplied with screws and gasket for fastening and fixing the valve to the base.



Alimentación Intermedia Intermediate power

CÓDIGO
CODE

05VB400000

La alimentación viene suministrada completa de tornillos y tóricas para la fijación de los componentes.
The intermediate power is supplied with screws and gasket for fastening and fixing the valve to the base.

05VB100000

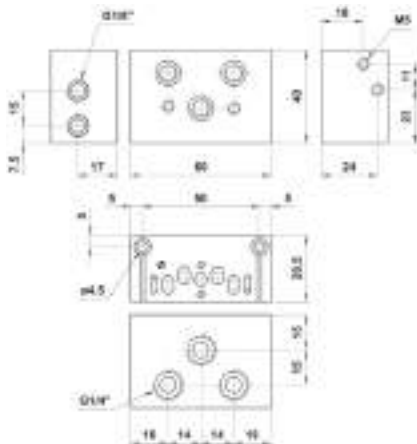

05VB200000

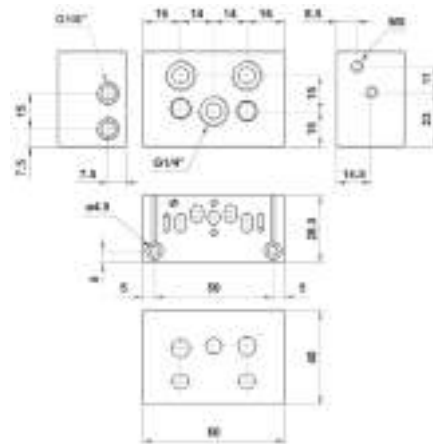

05VB300000

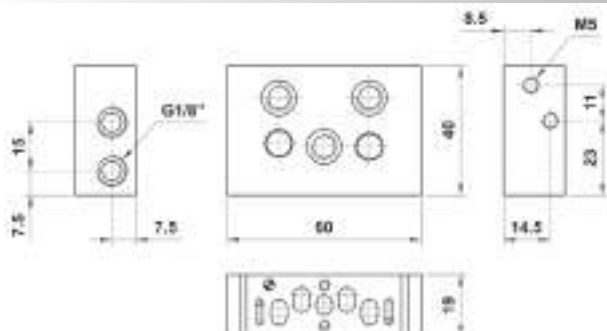

05VB400000

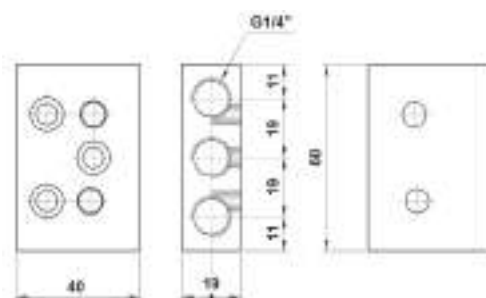

Bases Múltiples y Accesorios / Multiple Bases and Accessories



Tapón Intermedio
Intermediate Plug

CÓDIGO
CODE

05VB800000

El Tapón intermedio viene suministrado completo de tornillos y juntas para la fijación de las válvulas y las bases.
The Intermediate Plug is supplied with screws and gasket for fastening and fixing the valve to the base.



Junta para tapón intermedio
Gasket for Intermediate plug

CÓDIGO
CODE

05VB700000

La junta es suministrada con espiga de M8
The gasket is supplied with M8 dowel



Placa de cierre
Cover Plate

CÓDIGO
CODE

05VB900000

La placa de cierre viene suministrada completa de tornillos y juntas para la fijación de las válvulas y las bases.
The Cover Plate is supplied with screws and gasket for fastening and fixing the valve to the base.



Base simple
Individual base

CÓDIGO
CODE

05VB500000

La base viene suministrada completa de tornillos y juntas para la fijación de las válvulas y la base.
The base is supplied with screws and gasket for fastening and fixing the valve to the base.

05VB500000

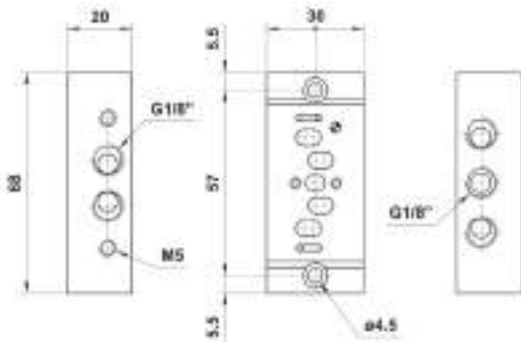

05VB700000

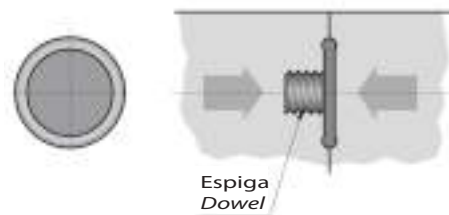

05VB800000

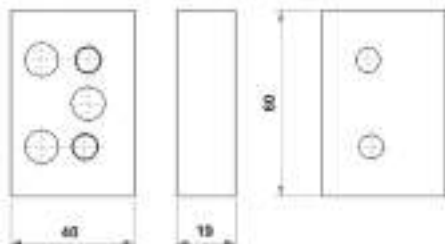

05VB900000



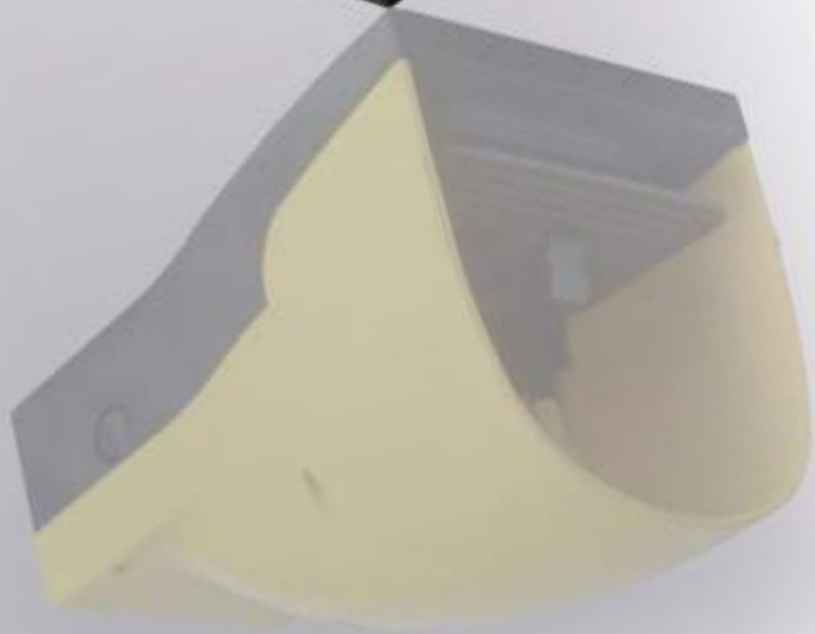

Serie 06V

Válvulas a pedal
Pedal Valve

Válvulas de pedal / Pedal Valve



5/2 Vías/Ways

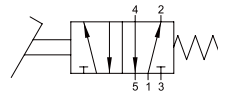

MONOESTABLE CON PROTECCIÓN
MONOSTABLE PEDAL VALVE WITH PROTECTION COVER

CÓDIGO CODE	VÍAS WAYS	MEDIDA SIZE
06V 00 0 00 01	5/2	1/4

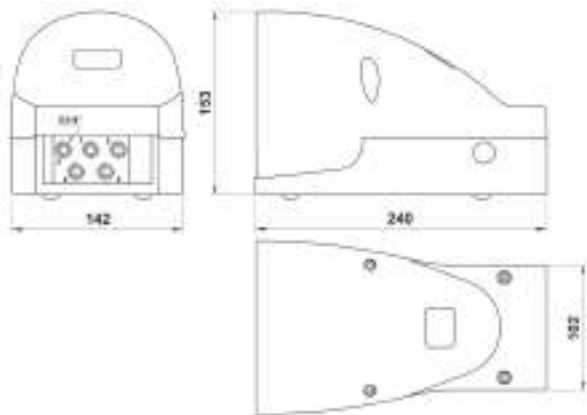

5/2 Vías/Ways

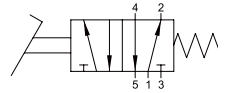

MONOESTABLE CON PROTECCIÓN Y MECANISMO DE SEGURIDAD
MONOSTABLE PEDAL VALVE WITH PROTECTION COVER AND SAFETY FEATURE

CÓDIGO CODE	VÍAS WAYS	MEDIDA SIZE
06V 00 0 00 02	5/2	1/4

5/2 Vías/Ways

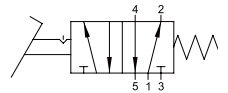

BIESTABLE CON PROTECCIÓN
BISTABLE PEDAL VALVE WITH PROTECTION COVER

CÓDIGO CODE	VÍAS WAYS	MEDIDA SIZE
06V 00 0 00 03	5/2	1/4

Características Técnicas - Technical Characteristics

ROSCAS / THREADED
PRESIÓN DE EJERCICIO / OPERATING PRESSURE
TEMPERATURA MÁXIMA / MAX TEMPERATURE
MATERIALES / MATERIAL

PROTECCIÓN / PROTECTION

1/4

1/4
 2 - 10 Bar
 +60° C

CUERPO EN ALUMINIO
 ALUMINIUM BODY
CORREDERA EN ALUMINIO NIQUELADO
 NICKEL-PLATED SPOOL
JUNTAS EN NBR
 NBR SEALS
TECNOPOLÍMERO
 POLYMER

Gráfico de Caudal / Flow Rates

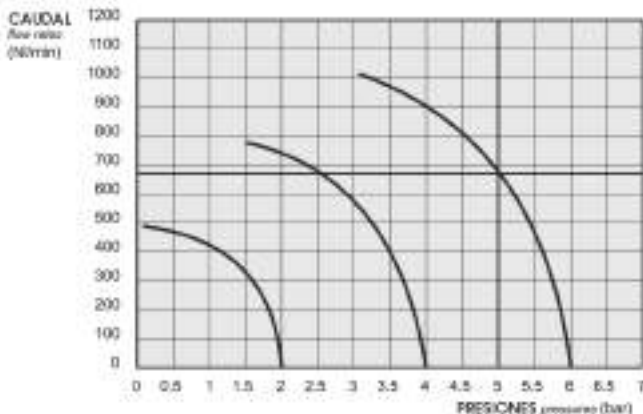



Serie 07V

ELECTROPILOTOS
SOLENOID VALVES

Electropilotos / Solenoid Valves



Características Técnicas - Technical Characteristics

ROSCA / THREADED

CAUDAL A 6 BAR CON Δp 1 bar

6 bar FLOW RATE WITH Δp 1 bar

PRESIÓN DE EJERCICIO / OPERATING PRESSURE

TEMPERATURA / TEMPERATURE

MATERIALES / MATERIAL

TENSIÓN SOLENOIDE / SOLENOID VOLTAGE

POTENCIA MÍNIMA / MINIMUM POWER

COMANDO MANUAL / MANUAL CONTROL

PAR DE APRIETE DE LA TUERCA AL SOLENOIDE

TORQUE OF TIGHTENING THE NUT SOLENOID

1/8 - AUTOMÁTICO/AUTOMATIC Ø4
30 NI/min

0 - 10 Bar
-10° / +60° C

CUERPO EN ALUMINIO ANODIZADO
ANODISED ALUMINIUM BODY

JUNTAS EN NBR
NBR SEALS

24V DC - 12V DC - 24V AC - 110V AC - 220V AC
3W - 5VA

BIESTABLE / BISTABLE
0.6 Nm

Tabla de códigos de pedido - Article codes to be used for ordering

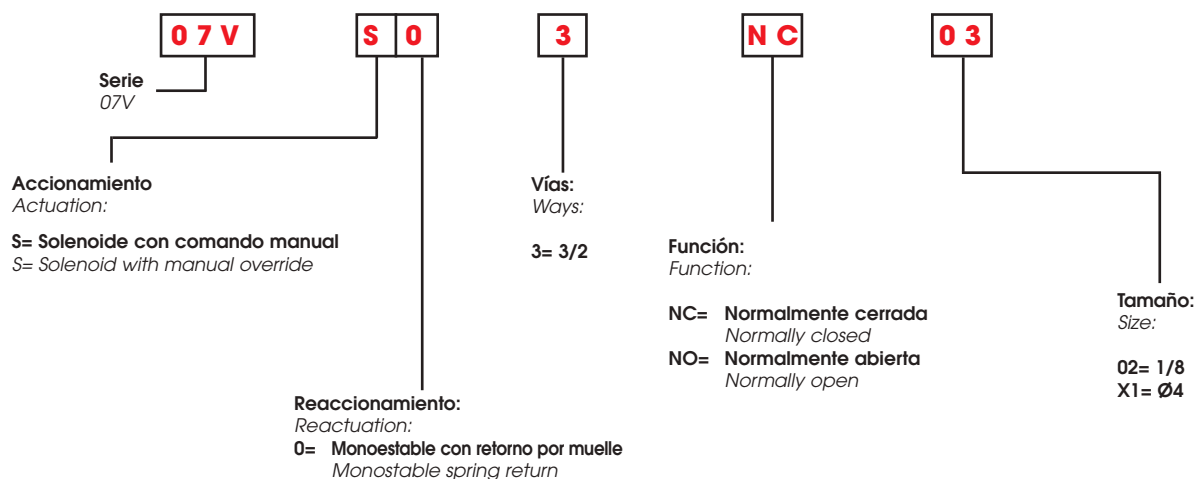

Electropilotos con comando manual / Solenoid with manual override

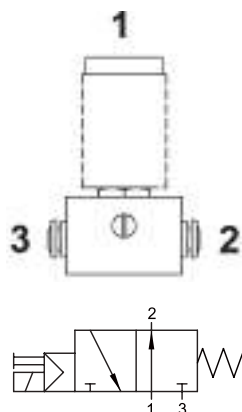

07VS03NO02
07VS03NOX1

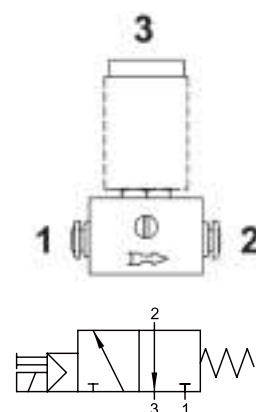

07VS03NC02
07VS03NCX1

3/2 Vie/Ways

CON COMANDO MANUAL
WITH MANUAL OVERRIDE

CÓDIGO CODE	VÍAS WAYS	FUNCIÓN FUNCTION	TAMAÑO SIZE
07V S0 3 NC 02	3/2	NC	1/8
07V S0 3 NC X1	3/2	NC	Ø4
07V S0 3 NO 02	3/2	NO	1/8
07V S0 3 NO X1	3/2	NO	Ø4

07V S0 3 NC X1 07V S0 3 NO X1

07V S0 3 NC 02 07V S0 3 NO 02

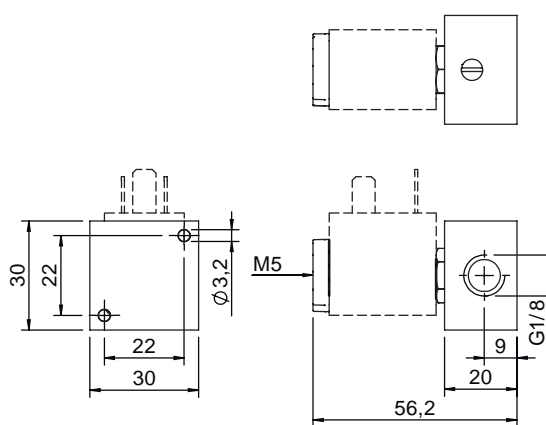
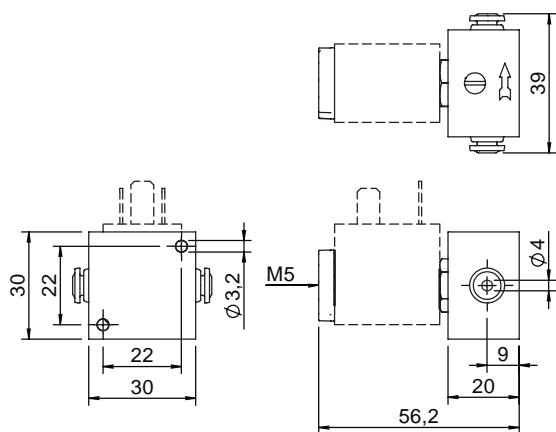

Bobinas y Conectores/ Solenoids and Connectors

Bobinas Solenoids

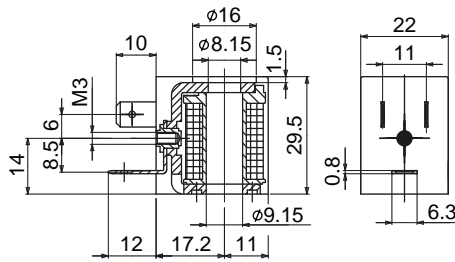

CÓDIGO CODE	TENSIÓN BOBINA SOLENOID VOLTAGE	POTENCIA POWER
SOL01012C1000	12V DC	3W
SOL01024C1000	24V DC	3W
SOL01024A2000	24V AC	5VA
SOL01110A2000	110V AC	5VA
SOL01220A2000	220V AC	5VA

Características Técnicas - Technical Characteristics

TOLERANCIA DE TENSIÓN / VOLTAGE TOLERANCE
 CLASE DE AISLAMIENTO / CLASS OF ISOLATION
 GRADO DE PROTECCIÓN / DEGREE OF PROTECTION
 CICLO DE TRABAJO / DUTY CYCLE
 TERMINALES / TERMINALS

±10%
 F CEI EN 60085
 IP65 IEC 60529 CON CONECTOR (WITH CONNECTOR)
 100%
 DIN 43650 B

Conectores Connectors

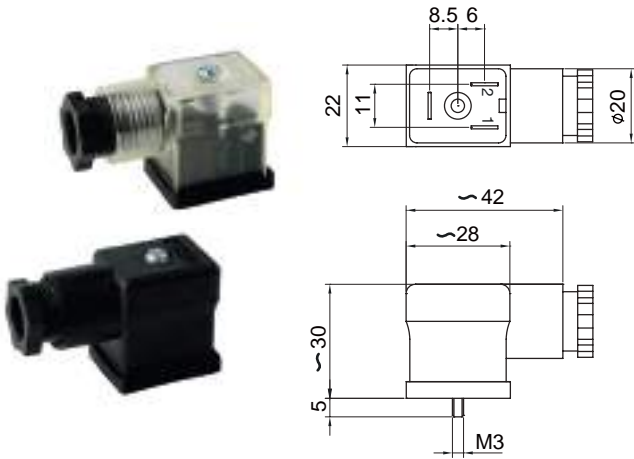

CÓDIGO CODE	COLOR COLOR	CARACTERÍSTICAS CHARACTERISTICS
CON0100001	NEGRO / BLACK	STANDARD A 2 POLOS (2 PIN)
CON0202400	TRANSPARENTE / TRANSPARENT	LED + VDR 0 - 24V
CON0211000	TRANSPARENTE / TRANSPARENT	LED + VDR 110V
CON0225000	TRANSPARENTE / TRANSPARENT	LED + VDR 220V

VDR: Dotado de varistor como dispositivo de protección de sobretensiones.
 Fitted with varistors as surge protection device.

ESQUEMA ELÉCTRICO / WIRING

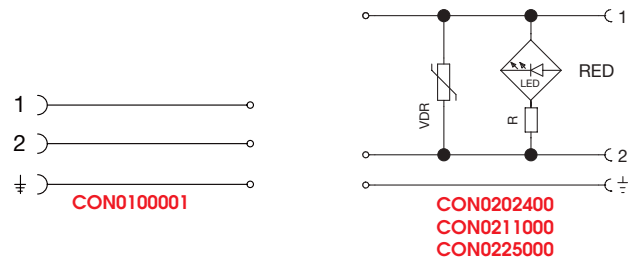

Características Técnicas - Technical Characteristics

GRADO DE PROTECCIÓN / DEGREE OF PROTECTION
 JUNTA / GASKET
 DIAMETRO CABLE / CABLE DIAMETER

IP65 IEC 60529
 JUNTA DE PERFIL / PROFIL GASKET
 6 ± 8 mm

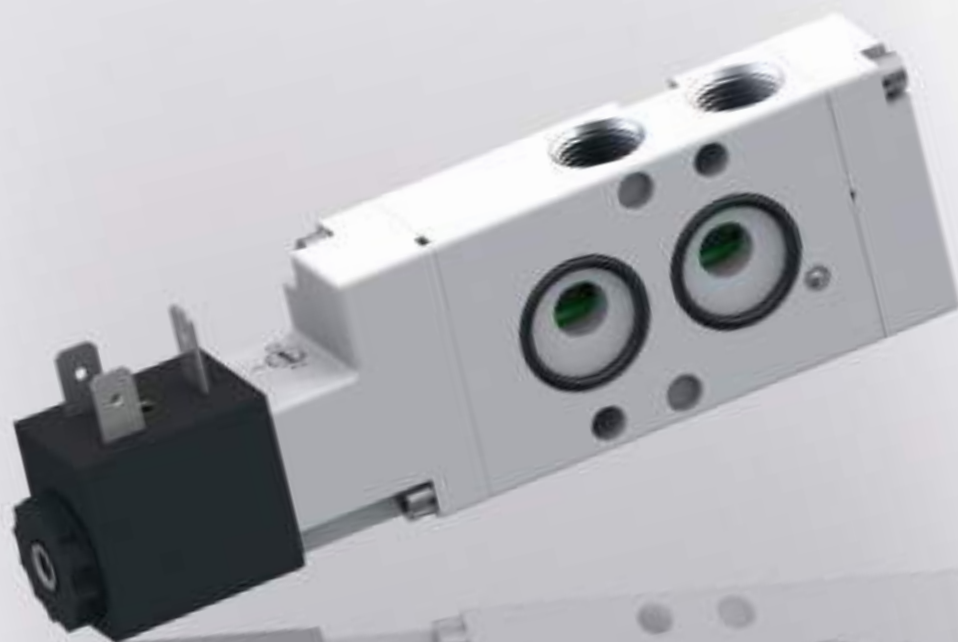

Serie 08V

VÁLVULAS NAMUR
NAMUR VALVE

Válvulas de accionamiento Electroneumático / Solenoid Pilot Valve



Características Técnicas - Technical Characteristics

ROSCA / THREADED
CAUDAL A 6 BAR CON Δp 1 bar
6 bar FLOW RATE WITH Δp 1 bar
PRESIÓN DE EJERCICIO / OPERATING PRESSURE

TEMPERATURA / TEMPERATURE
MATERIALES / MATERIAL

TENSIÓN SOLENOIDE / SOLENOID VOLTAGE
POTENCIA MÍNIMA / MINIMUM POWER
COMANDO MANUAL / MANUAL CONTROL
PAR DE APRIETE DE LA TUERCA AL SOLENOIDE
TORQUE OF TIGHTENING THE NUT SOLENOID
NORMA DE REFERENCIA
REFERENCE STANDARD

1/4

1/4
 1200 NI/min

MONOESTABLE / MONOSTABLE: 2 - 10 Bar
BIESTABLE / BISTABLE: 1 - 10 Bar
 -10° / +60° C
CUERPO EN ALUMINIO ANODIZADO Y BARNIZADO
ANODISED AND PAINTED ALUMINIUM BODY
CORREDERA EN ALUMINIO NIQUELADO QUÍMICAMENTE
CHEMICAL NICKEL-PLATED SPOOL
JUNTAS EN NBR
NBR SEALS
 24V DC - 12V DC - 24V AC - 110V AC - 220V AC
 2W - 3VA
BIESTABLE / BISTABLE
 0,6 Nm
VDI/VDE 3845

Tabla de códigos de pedido - Article codes to be used for ordering

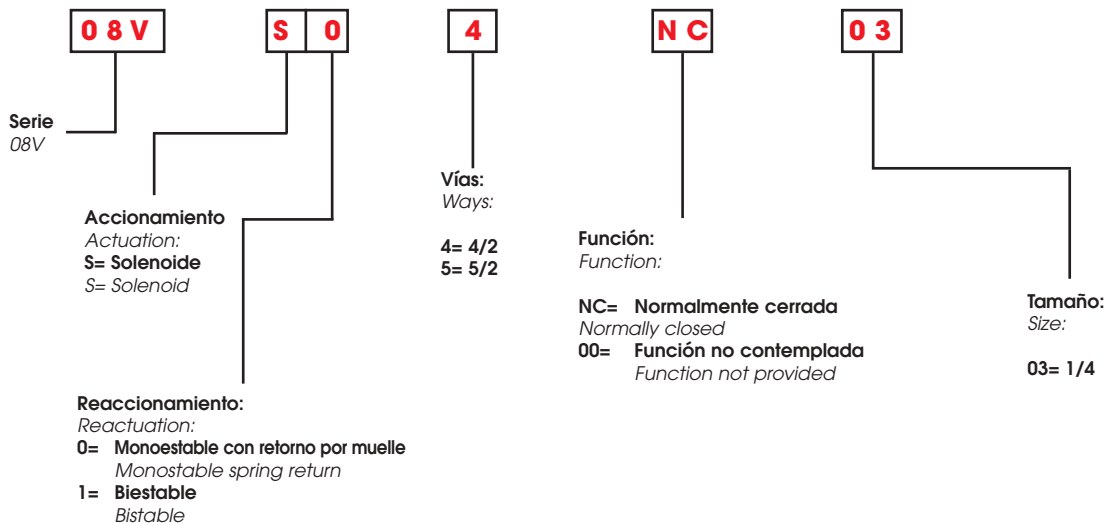

Esquema de funcionamiento de la válvula NAMUR 4/2 / Schematic diagram of the valve NAMUR 4 / 2

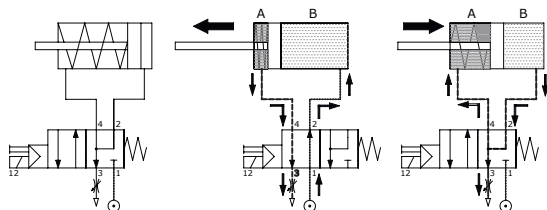

Para evitar que en la fase de retorno el aire sucio del ambiente externo entre en la cámara A del cilindro, parte del aire que escapa de la cámara B viene dirigido a la misma cámara A.

To prevent the return phase of the external dirty air enters the chamber in the cylinder, the air escaping from the chamber B is routed to the same room.

Válvulas de accionamiento Electroneumático / Solenoid Pilot Valve

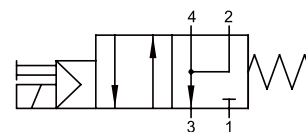

4/2 Vías/Ways

MONOESTABLE CON RETORNO POR MUELLE
MONOSTABLE SPRING RETURN

CÓDIGO CODE	VÍAS WAYS	FUNCIÓN FUNCTION	TAMAÑO SIZE
08V S0 4 NC 03	4/2	NC	1/4

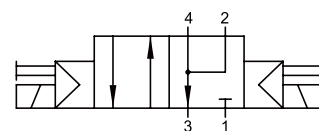

4/2 Vías/Ways

BIESTABLE
BISTABLE

CÓDIGO CODE	VÍAS WAYS	TAMAÑO SIZE
08V S1 4 00 03	4/2	1/4

08V S0 4 NC 03

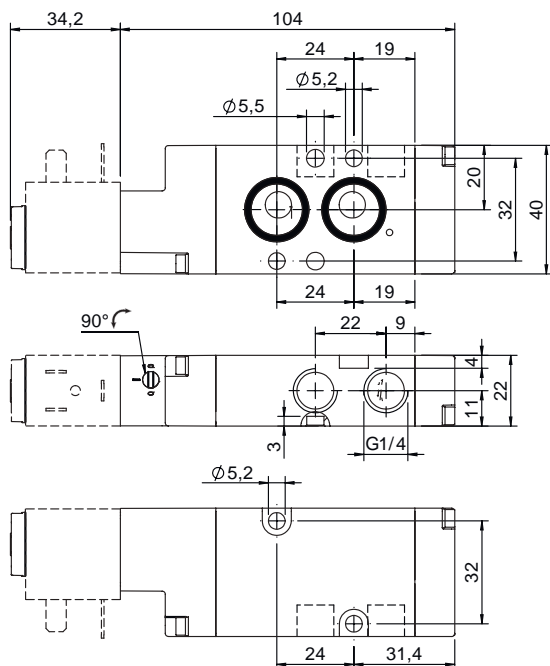

08V S1 4 00 03

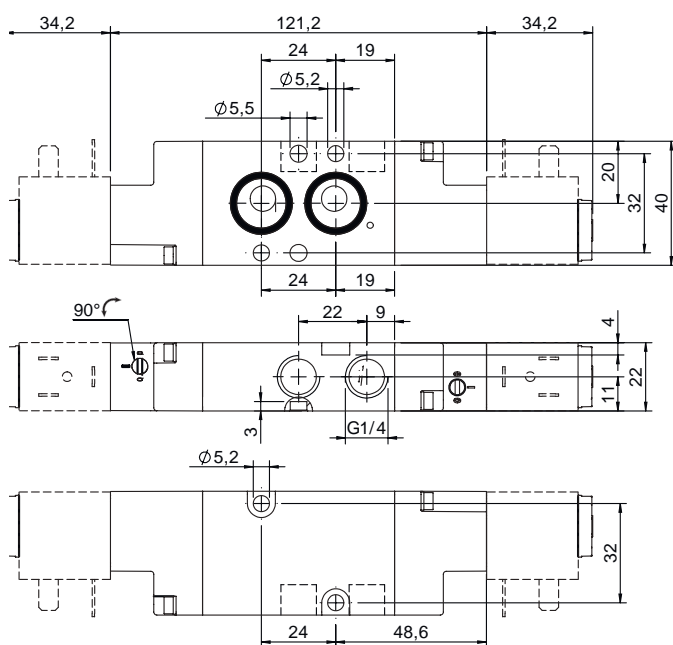

Válvulas de accionamiento Electroneumático / Solenoid Pilot Valve

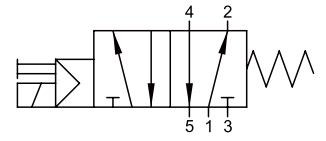

5/2 Vías/Ways

MONOESTABLE CON RETORNO POR MUELLE
MONOSTABLE SPRING RETURN

CÓDIGO CODE	VÍAS WAYS	TAMAÑO SIZE
08V S0 5 00 03	5/2	1/4

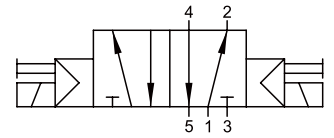

5/2 Vías/Ways

BIESTABLE
BISTABLE

CÓDIGO CODE	VÍAS WAYS	TAMAÑO SIZE
08V S1 5 00 03	5/2	1/4

08V S0 5 00 03

08V S1 5 00 03

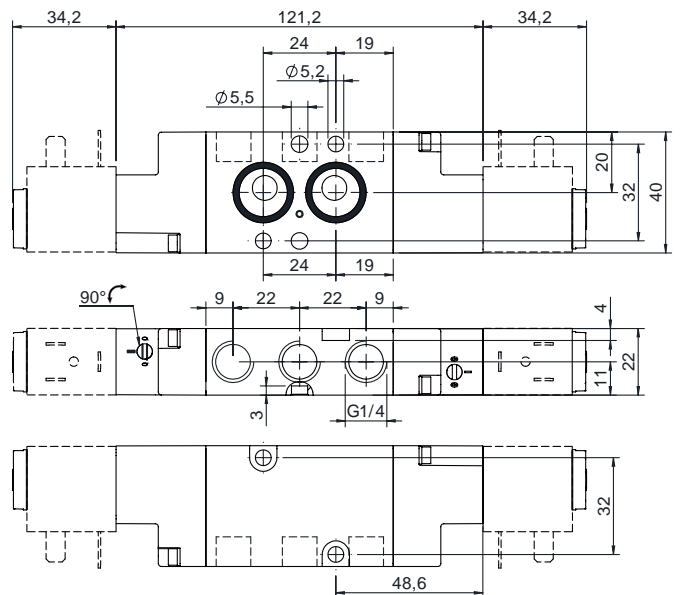
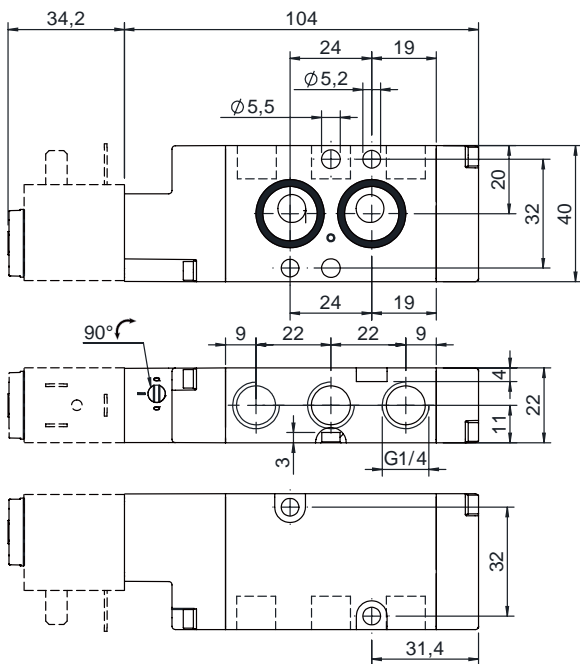

Válvulas de accionamiento neumático / Pneumatic Valve

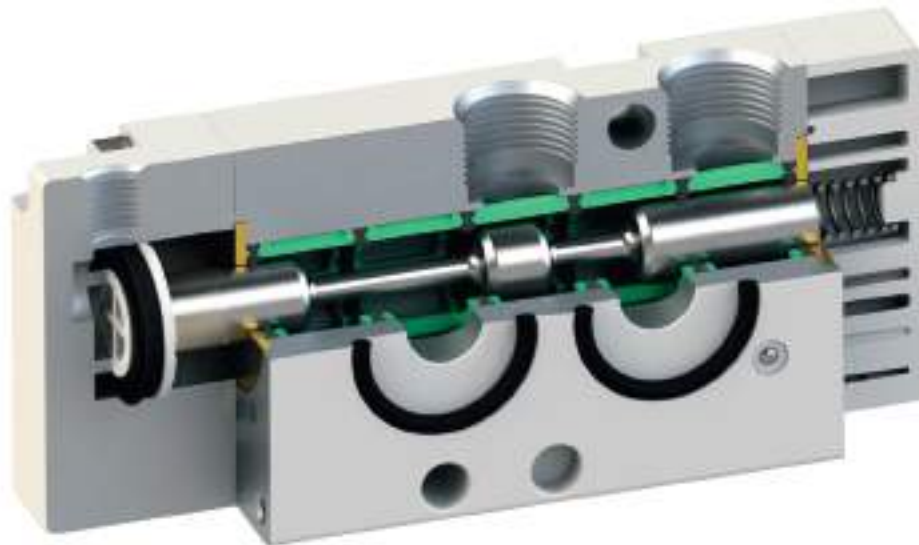

Características Técnicas - Technical Characteristics

ROSCA / THREADED
CAUDAL A 6 BAR CON Δp 1 bar
6 bar FLOW RATE WITH Δp 1 bar
PRESIÓN DE EJERCICIO / OPERATING PRESSURE
PRESIÓN DE ACCIONAMIENTO / PRESSURE DRIVE

TEMPERATURA / TEMPERATURE
MATERIALES / MATERIAL

NORMA DE REFERENCIA
REFERENCE STANDARD

1/4

1/4
1200 NI/min

0 - 10 Bar

MONOESTABLE / MONOSTABLE: 2 - 10 Bar

BIESTABLE / BISTABLE: 1 - 10 Bar

-10° / +60° C

CUERPO EN ALUMINIO ANODIZADO Y BARNIZADO
ANODISED AND PAINTED ALUMINIUM BODY
CORREDERA EN ALUMINIO NIQUELADO QUÍMICAMENTE
CHEMICAL NICKEL-PLATED SPOOL

JUNTAS EN NBR
NBR SEALS
VDI/VDE 3845

Tabla de códigos de pedido - Article codes to be used for ordering

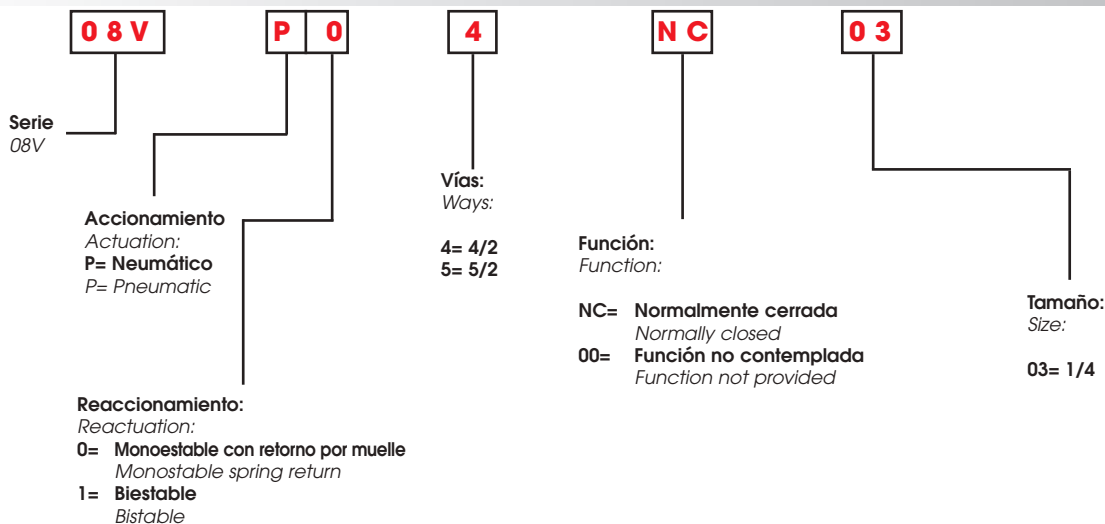

Esquema de funcionamiento de la válvula NAMUR 4/2 / Schematic diagram of the valve NAMUR 4 / 2

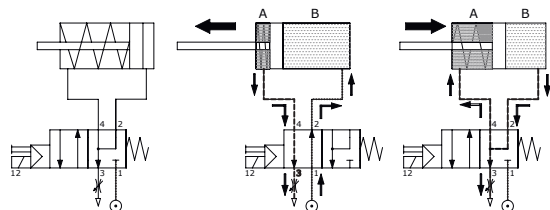

Para evitar que en la fase de retorno el aire sucio del ambiente externo entre en la cámara A del cilindro, parte del aire que escapa de la cámara B viene dirigido a la misma cámara A.

To prevent the return phase of the external dirty air enters the chamber in the cylinder, the air escaping from the chamber B is routed to the same room.

Válvulas de accionamiento neumático / Pneumatic Valve



4/2 Vías/Ways

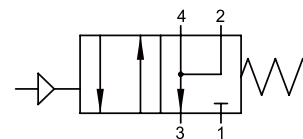

MONOESTABLE CON RETORNO POR MUELLE
MONOSTABLE SPRING RETURN

CÓDIGO CODE	VÍAS WAYS	FUNCIÓN FUNCTION	TAMAÑO SIZE
08V P0 4 NC 03	4/2	NC	1/4



4/2 Vías/Ways

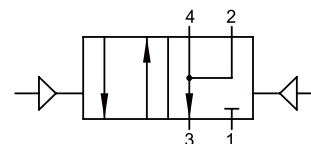

BIESTABLE
BISTABLE

CÓDIGO CODE	VÍAS WAYS	TAMAÑO SIZE
08V P1 4 00 03	4/2	1/4

08V P0 4 NC 03

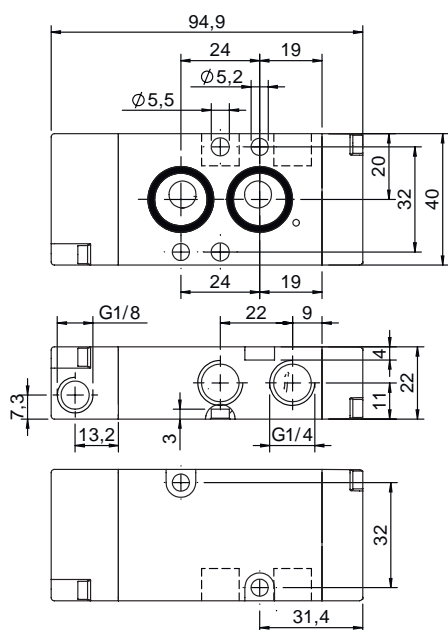

08V P1 4 00 03

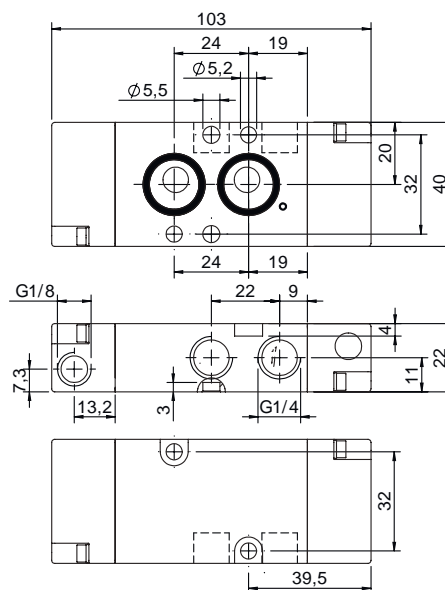

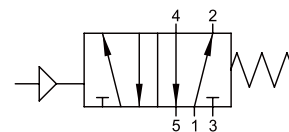
Válvulas de accionamiento neumático / Pneumatic Valve

5/2 Vías/Ways

MONOESTABLE CON RETORNO POR MUELLE
MONOSTABLE SPRING RETURN

CÓDIGO CODE	VÍAS WAYS	TAMAÑO SIZE
08V P0 5 00 03	5/2	1/4

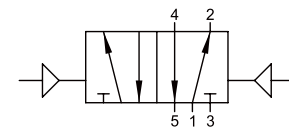

5/2 Vías/Ways

BIESTABLE
BISTABLE

CÓDIGO CODE	VÍAS WAYS	TAMAÑO SIZE
08V P1 5 00 03	5/2	1/4

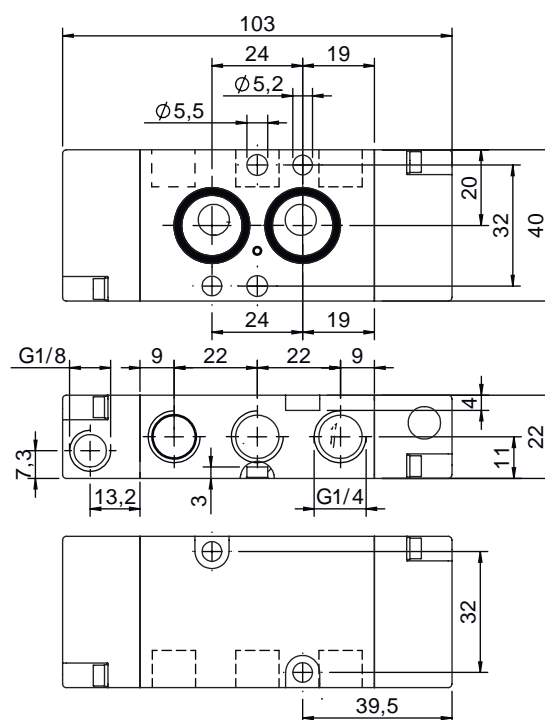
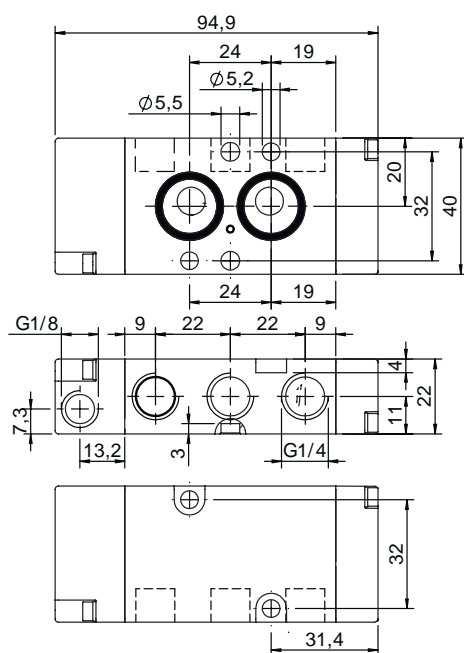
08V P0 5 00 03
08V P1 5 00 03

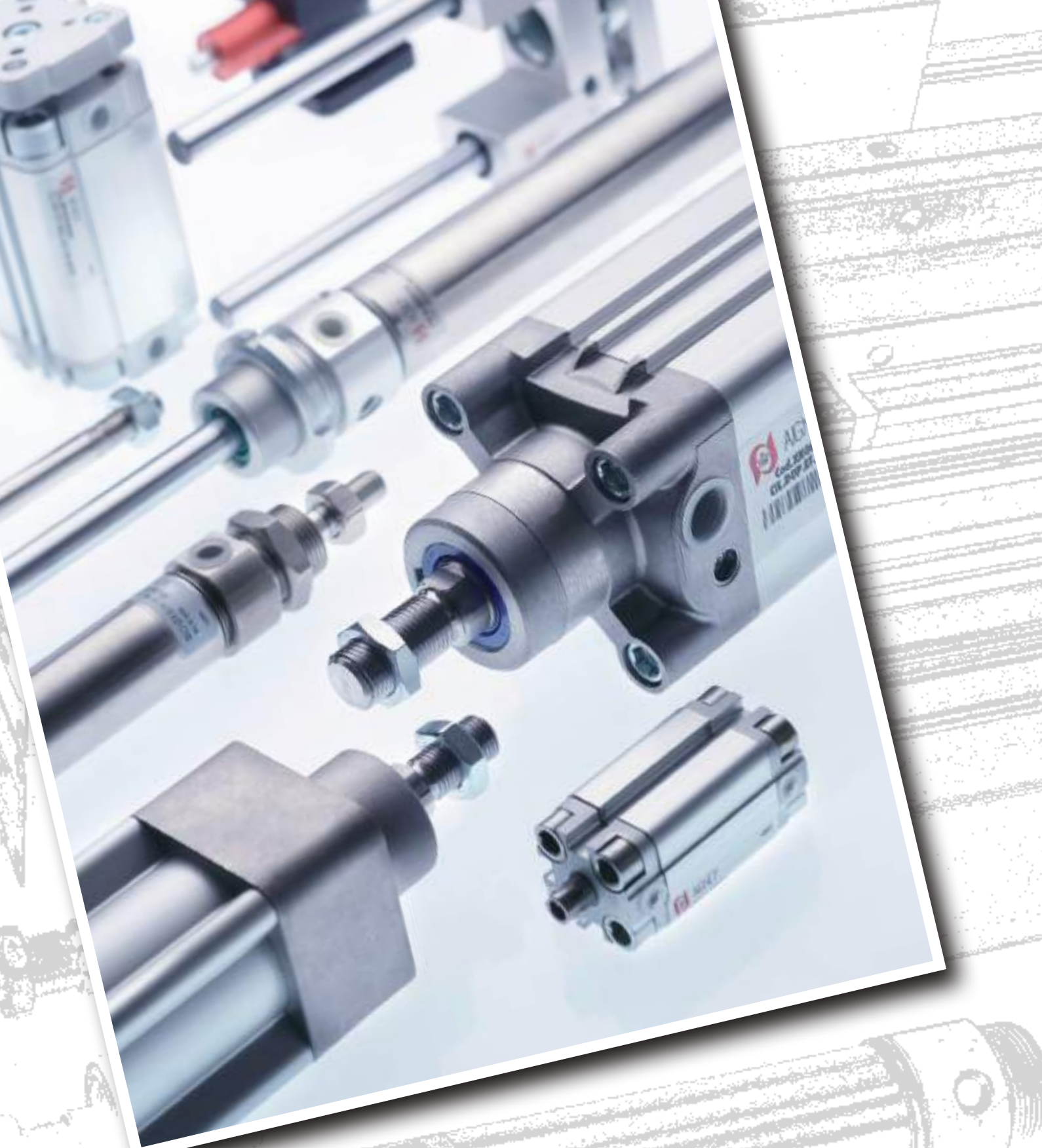

Serie **Cylinders**

CILINDROS Y ACCESORIOS
CYLINDERS AND ACCESSORIES



16.4 Cilindros de cartucho / Cartridge Cylinders

Vástago roscado
Vástago no roscado

*Threaded piston rod
No-threaded piston rod*

16.13 Unidades de bloqueo de vástago / Piston Rod Lock

16.7
Minicilindros / Mini Cylinders

Simple y doble efecto
Amortiguación neumática
Vástago simple o pasante

ISO 6432 (Ø8-Ø25)

*Single and double-acting
cushioned
Single or Through piston rod*

16.17 Minicilindros Inox / Stainless Steel Mini Cylinders

Doble Efecto

Double-acting

ISO 6432 (Ø16 - Ø20 - Ø25)

16.21
Cilindros A95 / Cylinders A95

Simple y Doble Efecto
Vástago simple o pasante
Amortiguación neumática

(Ø32-Ø63)

*Single and Double-acting
Single or Through piston rod
cushioned*

16.29
Cilindros Compactos / Compact Cylinders

Simple y Doble Efecto
Vástago simple o pasante
Antirrotación

*Single and Double-acting
Single or Through piston rod
Anti-rotation*

16.41 Cilindros Carrera Corta / Short Stroke Cylinders

Simple y Doble Efecto
Vástago simple o pasante
Antirrotación

*Single and
Double-acting
Single or Through
piston rod
Anti-rotation*

16.54
Cilindros Serie X / Cylinders X Series

ISO 15552

Simple y Doble
efecto, Vástago
simple o pasante
Cilindro Tándem
Cilindro
Contrapuesto

*Single and Double-acting
Single or Through piston rod
Tandem cylinder
Opposed cylinder*

16.60 Unidades de bloqueo de vástago / Piston Rod Lock



16.62 Cilindros Rotativos / Rotary Cylinders



Versión con piñon macho
Versión con orificio hembra

*Model with male pinion
Model with female bore*

16.67 Cilindros Serie E / Cylinders E Series



Simple y Doble efecto Vástago
simple o pasante

*Single and Double-acting
Single or Through piston rod*

ISO 6431 (Ø32-Ø320)

16.77 Cilindros Serie V / Cylinders V Series



Simple y Doble efecto
Vástago simple o pasante

*Single and Double-acting
Single or Through piston rod*

ISO 6431 (Ø32-Ø125)

16.78 Cilindros Serie NHA / Cylinders NHA Series



Simple y Doble efecto Vástago
simple o pasante

*Single and Double-acting
Single or Through piston rod*

ISO 15552 Interface (Ø32-Ø100)

16.84 Cilindros Serie P / Cylinders P Series



Simple y Doble efecto, Vástago
simple o pasante

*Single and Double-acting
Single or Through piston rod*

ISO 15552 Interface (Ø32-Ø250)

16.100 Unidades de Guiado / Guide Units



ISO 6431 VDMA (Ø32-Ø100)
ISO 6432 (Ø12-Ø25)

16.108 Sensores / Sensor



NB

Los sensores magnéticos no pueden ser utilizados en atmósfera potencialmente explosiva según la Directiva ATEX. According to the Directive ATEX, Magnetic Switches cannot be used in potentially explosive environment.

Cilindros de Cartucho / Cartridge Cylinders

Los cilindros de cartucho de simple efecto han sido estudiados para ser utilizados en pequeños espacios. Su rosca externa permite un fácil montaje.

The single-acting cartridge cylinders have been studied and designed to be used in reduced spaces. The external thread ensures an easy assembly.



Características Técnicas / Technical Characteristics

Presiones / Pressures

Presión mínima / Minimum pressure: 2 bar (0.2 MPa)
Presión máxima / Maximum pressure: 7 bar (0.7 MPa)

Temperaturas / Temperatures

Temperatura mínima / Minimum temperature: 0 °C
 (-20 °C con aire seco / with dry air)
Temperatura máxima / Maximum temperature: +80 °C

Fluidos compatibles / Fluids

Aire comprimido filtrado lubricado y no lubricado.
 Filtered and lubricated compressed air as well as non lubricated air.

Funcionamiento / Functioning

Simple efecto, Vástago roscado y no roscado.
 Single-acting, Threaded piston rod and No-threaded piston rod.

Diámetros / Bores

6 - 10 - 16 mm.

Carreras / Strokes

Carreras Standard / Standard Strokes
5 - 10 - 15 mm.

Características Técnicas / Technical Characteristics

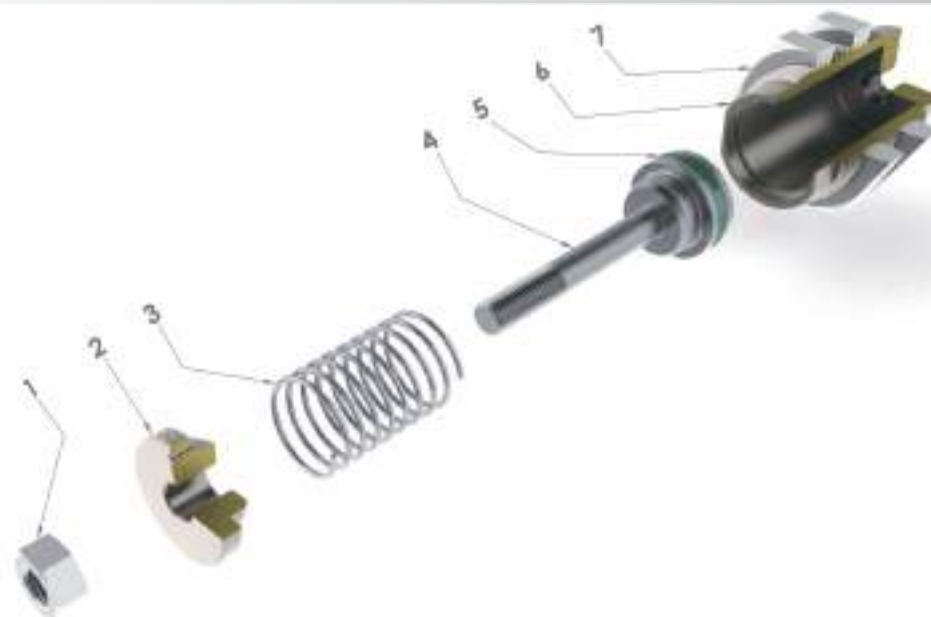

Materiales y Componentes / Component Parts and Materials

- | | |
|--|-----------------------------------|
| 1 Tuerca vástago en acero zincado | 1 Zinc-plated steel Nut |
| 2 Cojinete en latón niquelado | 2 Nickel plated brass Bush |
| 3 Muelle en acero | 3 Steel Spring |
| 4 Vástago pistón en acero AISI 303 | 4 Steel Piston rod AISI 303 |
| 5 Junta pistón en poliuretano | 5 Polyurethane Rod seal |
| 6 Camisa cilindro en latón niquelado | 6 Nickel plated brass Shape body |
| 7 Tuerca de fijación cilindro en acero zincado | 7 Zinc-plated steel Locking screw |

Ejemplo de pedido / How to Order

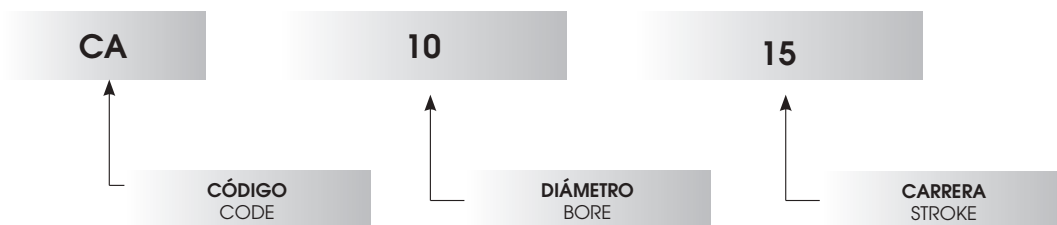

Ø mm.	CARRERAS - STROKES		
	5	10	15
6	10 gr	12.5 gr	15 gr
10	27 gr	32 gr	36 gr
16	71 gr	78 gr	87 gr

CARRERAS STANDARD mm. - STD STROKES

Ø mm.	5	10	15
6	▲ ■	▲ ■	▲ ■
10	▲ ■	▲ ■	▲ ■
16	▲ ■	▲ ■	▲ ■

- ▲ CA SIMPLE EFECTO No ROSCADO - SINGLE-ACTING NO-THREADED PISTON ROD
 ■ CAF SIMPLE EFECTO ROSCADO - SINGLE-ACTING THREADED PISTON ROD

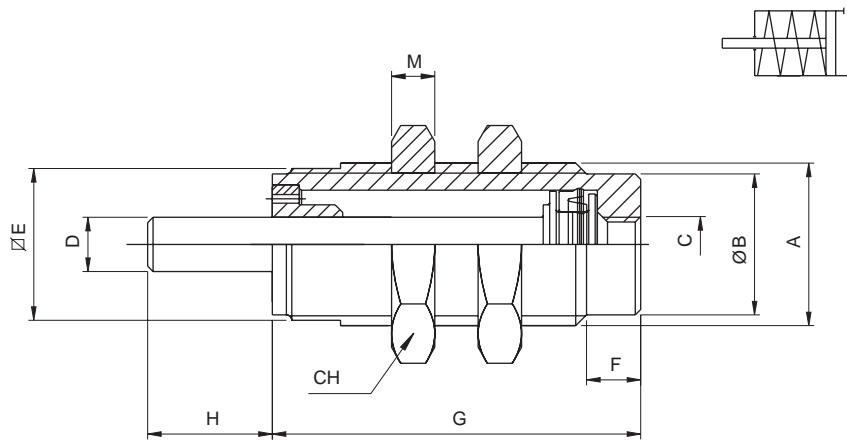

CA

SIMPLE EFECTO NO ROSCADO - SINGLE-ACTING NO-THREADED PISTON ROD

Ø mm.	A	B	C	D	E	F	G - CARRERA			H	M	CH
							5	10	15			
6	M10x1	8.5	M5	3	9	5	18.5	25.5	32.5	9	3	14
10	M15x1.5	13	M5	5	14	5	20.5	27	34	11.5	4	19
16	M22x1.5	19	M5	5	20	6	23.5	29.5	36	14	5	27

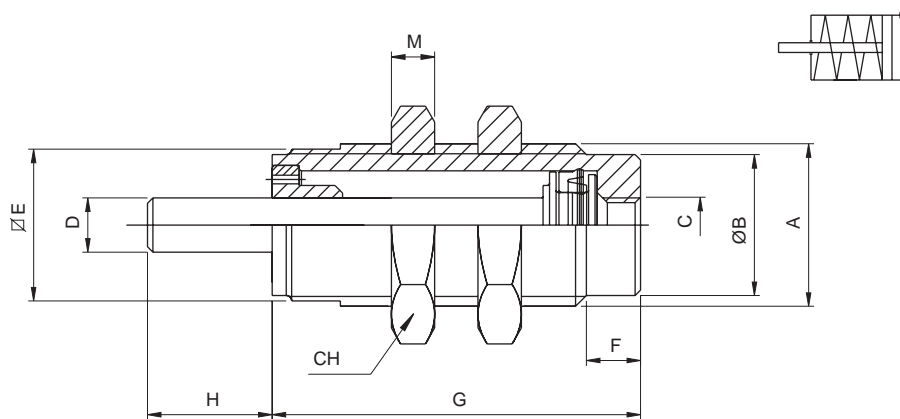

CAF

SIMPLE EFECTO ROSCADO - SINGLE-ACTING THREADED PISTON ROD

Ø mm.	A	B	C	D	E	F	G - CARRERA			H	M	CH
							5	10	15			
6	M10x1	8.5	M5	M3	9	5	18.5	25.5	32.5	9	3	14
10	M15x1.5	13	M5	M4	14	5	20.5	27	34	11.5	4	19
16	M22x1.5	19	M5	M5	20	6	23.5	29.5	36	14	5	27

Minicilindros Iso 6432 / Mini Cylinders Iso 6432

Los cilindros de esta serie, realizados según las normas DIN ISO 6432, están adaptados para cualquier sector industrial. Su gran capacidad de deslizamiento, garantiza la máxima productividad del sistema. Funcionalidad y re-sistencia están garantizadas gracias a una particular operación de montaje denominada "double rolling" con la cual las tapas quedan unidas a la camisa.

The cylinders included in this range, manufactured in conformity with the Standards DIN ISO 6432 can be used in any industrial fields. The high sliding characteristics guarantee the maximum productivity of the system.

*By using a special assembling operation called "double rolling" to join the end covers to the barrel, functionality and resistance are ensured.



Características Técnicas / Technical Characteristics

Presiones / Pressures

Presión mínima / Minimum pressure: **1 bar** (0,1 MPa)
Presión máxima / Maximum pressure: **10 bar** (1 MPa)

Temperaturas / Temperatures

Temperatura mínima / Minimum temperature: 0 °C
(-20 °C con aire seco / with dry air)
Temperatura máxima / Maximum temperature: +80 °C

Fluidos compatibles / Fluids

Aire comprimido filtrado lubricado y no lubricado.
Filtered and lubricated compressed air as well as non lubricated air.

Funcionamiento / Functioning

Simple y doble efecto amortiguado, Vástago simple o pasante Magnético y no Magnético.
Single and Double-acting cushioned, Single or through piston rod, Magnetic and no-magnetic

Diámetros / Bores

8 - 10 - 12 - 16 - 20 - 25 mm.

Carreras / Strokes

Carreras Standard / Standard Strokes
De 10 a 320 mm / From 10 to 320 mm

Características Técnicas / Technical Characteristics

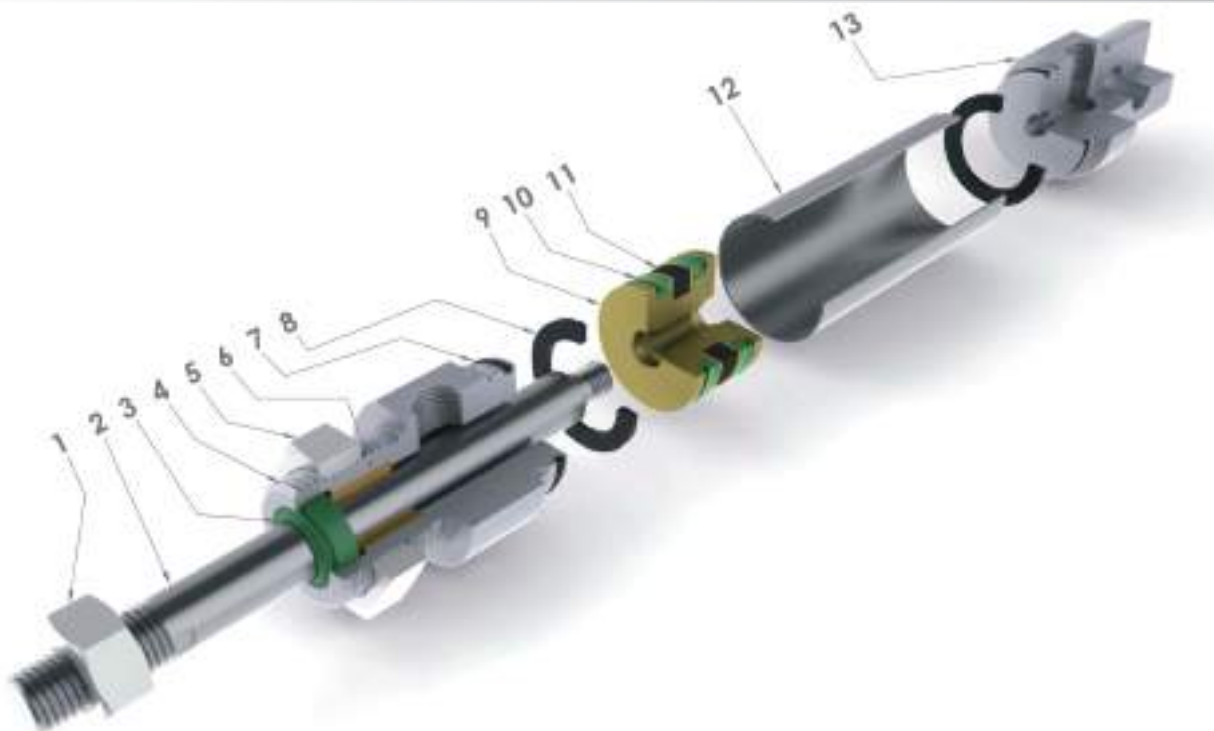

Materiales y Componentes / Component Parts and Materials

1 Tuerca en acero zincado	1 Zinc-plated steel Nut
2 Vástago en acero AISI 303	2 Steel AISI 303 Piston rod
3 Junta vástago en poliuretano	3 Polyurethane Rod seal
4 Tapa anterior en aluminio anodizado	4 Anodised aluminium Front cover
5 Tuerca en acero zincado	5 Zinc-plated steel Nut
6 Cojinete en bronce sinterizado	6 Sintered bronze Bearing
7 Junta tórica en NBR	7 NBR O-RING Seals
8 Paragolpes en neopreno	8 Neoprene Bumper
9 Pistón en latón	9 Brass Piston
10 Junta pistón en poliuretano	10 Polyurethane Piston seal
11 Magnete en plastoferrita	11 Bonded Ferrite Magnet
12 Camisa minicilindro en acero INOX AISI 304	12 Stainless Steel AISI 304 Mini cylinder shape body
13 Tapa posterior en aluminio anodizado	13 Anodised aluminium Back cover

Fuerzas y Consumos / Forces And Consumptions

FUERZA DE EMPUJE Y TRACCIÓN - THRUST AND TRACTION FORCES

Ø Cilindro Ø Cylinder	Ø Vástago Ø Rod	Superficie útil en mm ² Working Surface in mm ²	Presión de trabajo en bar Operating pressure in bar									
			1	2	3	4	5	6	7	8	9	10
			Fuerza desarrollada en N Output force in N									
Ø8	4	Empuje / Thrust = 50,2	5	10	15	20	25	30	35	40	45	50
		Tracción / Traction = 37,7	3	6	9	12	15	18	21	24	27	30
Ø10	4	Empuje / Thrust = 78,5	7	14	21	28	35	42	49	56	63	70
		Tracción / Traction = 66	6	12	18	24	30	36	42	48	54	60
Ø12	6	Empuje / Thrust = 113	10	20	30	40	50	60	70	80	90	100
		Tracción / Traction = 85	7,5	15	22	30	37	45	52	60	68	75
Ø16	6	Empuje / Thrust = 200	18	36	54	72	90	108	126	144	162	180
		Tracción / Traction = 173	16	32	48	64	80	96	112	128	144	160
Ø20	8	Empuje / Thrust = 314	28	56	84	112	140	168	196	224	252	280
		Tracción / Traction = 264	24	48	72	96	120	144	168	192	216	240
Ø25	10	Empuje / Thrust = 490	44	88	132	176	220	264	308	352	396	440
		Tracción / Traction = 412	36	72	108	144	180	216	252	288	324	360

FUERZA DEL MUELLE - SPRING TRACTION FORCES

Ø Cilindro Ø Cylinder	Carga Muelle Load Spring	Carrera / Stroke		
		10	25	50
		Fuerza desarrollada en N Output force in N		
Ø8	Carga Muelle en Reposo / Load of spring at rest	4,1	3,5	2,6
	Carga Muelle Comprimido / Load of compressed spring	4,5	4,5	4,5
Ø10	Carga Muelle en Reposo / Load of spring at rest	4,1	3,5	2,6
	Carga Muelle Comprimido / Load of compressed spring	4,5	4,5	4,5
Ø12	Carga Muelle en Reposo / Load of spring at rest	5,5	4,8	3,5
	Carga Muelle Comprimido / Load of compressed spring	6	6	6
Ø16	Carga Muelle en Reposo / Load of spring at rest	16,5	13,7	9
	Carga Muelle Comprimido / Load of compressed spring	18,3	18,3	18,3
Ø20	Carga Muelle en Reposo / Load of spring at rest	19	15,5	9,5
	Carga Muelle Comprimido / Load of compressed spring	21,5	21,5	21,5
Ø25	Carga Muelle en Reposo / Load of spring at rest	27	24	13,5
	Carga Muelle Comprimido / Load of compressed spring	29	29	29

CONSUMO CILINDRO - CYLINDER AIR CONSUMPTION

Ø Cilindro Ø Cylinder	Ø Vástago Ø Rod	Superficie útil en mm ² Working Surface in mm ²	Presión de trabajo en bar Operating pressure in bar									
			1	2	3	4	5	6	7	8	9	10
			Consumo aire en NL para cada 10mm. de carrera Air consumption in NL for each 10mm. of stroke									
Ø8	4	Empuje / Thrust = 50,2 Tracción / Traction = 37,7	0,001	0,002	0,002	0,003	0,003	0,004	0,004	0,005	0,005	0,006
Ø10	4	Empuje / Thrust = 78,5 Tracción / Traction = 66	0,002	0,002	0,003	0,004	0,005	0,005	0,006	0,007	0,008	0,009
Ø12	6	Empuje / Thrust = 113 Tracción / Traction = 85	0,002	0,003	0,005	0,006	0,007	0,008	0,009	0,010	0,011	0,012
Ø16	6	Empuje / Thrust = 200 Tracción / Traction = 173	0,004	0,006	0,008	0,010	0,012	0,014	0,016	0,018	0,020	0,022
Ø20	8	Empuje / Thrust = 314 Tracción / Traction = 264	0,006	0,009	0,013	0,016	0,019	0,022	0,025	0,028	0,031	0,035
Ø25	10	Empuje / Thrust = 490 Tracción / Traction = 412	0,010	0,015	0,020	0,025	0,029	0,034	0,039	0,044	0,049	0,054

Ejemplo de pedido / How to Order

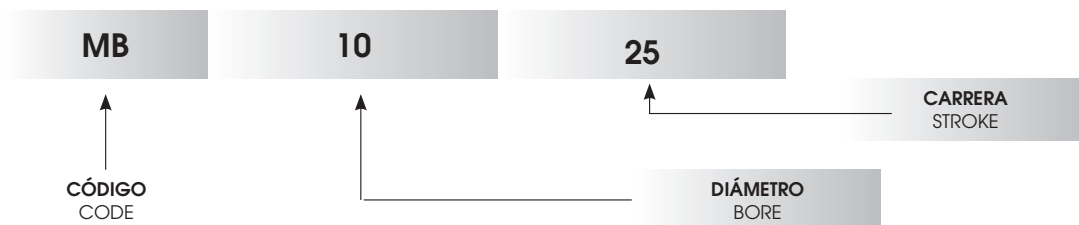

CARRERAS STANDARD mm. - STD STROKES

Ø mm.	10	25	50	80	100	125	160	200	250	320
8	▲●	▲●	▲●	●	●	●				
10	▲●	▲●	▲●	●	●	●				
12	▲●	▲●	▲●	●	●	●	●	●	●	
16	▲■□○	▲■□◆○	▲■□◆○	◆○	◆○	◆○	◆○	◆○	◆○	◆○
20	▲■□○	▲■□◆○	▲■□◆○	◆○	◆○	◆○	◆○	◆○	◆○	◆○
25	▲■□○	▲■□◆○	▲■□◆○	◆○	◆○	◆○	◆○	◆○	◆○	◆○

- ▲ MB SIMPLE EFECTO MAGNÉTICO - SINGLE-ACTING MAGNETIC
- MD SIMPLE EFECTO MAGNÉTICO - MUELLE EN EMPUJE - SINGLE-ACTING MAGNETIC - SPRING THRUST
- MF DOBLE EFECTO MAGNÉTICO - DOUBLE ACTING MAGNETIC
- MFN DOBLE EFECTO MAGNÉTICO TAPA TRONCA ALIMENTACIÓN 90° - DOUBLE ACTING MAGNETIC HEAD CUT, FEED AT 90°
- MFX DOBLE EFECTO MAGNÉTICO TAPA TRONCA ALIMENTACIÓN AXIAL - DOUBLE ACTING MAGNETIC HEAD CUT, FEED ON AXIS
- ◆ MH DOBLE EFECTO AMORTIGUADO MAGNÉTICO - DOUBLE ACTING CUSHIONED MAGNETIC
- MJ DOBLE EFECTO VÁSTAGO PASANTE MAGNÉTICO - DOUBLE ACTING MAGNETIC WITH DOUBLE ROD END
- ◆ ML DOBLE EFECTO VÁSTAGO PASANTE AMORTIGUADO MAGNÉTICO - DOUBLE ACTING CUSHIONED MAGNETIC WITH DOUBLE ROD END

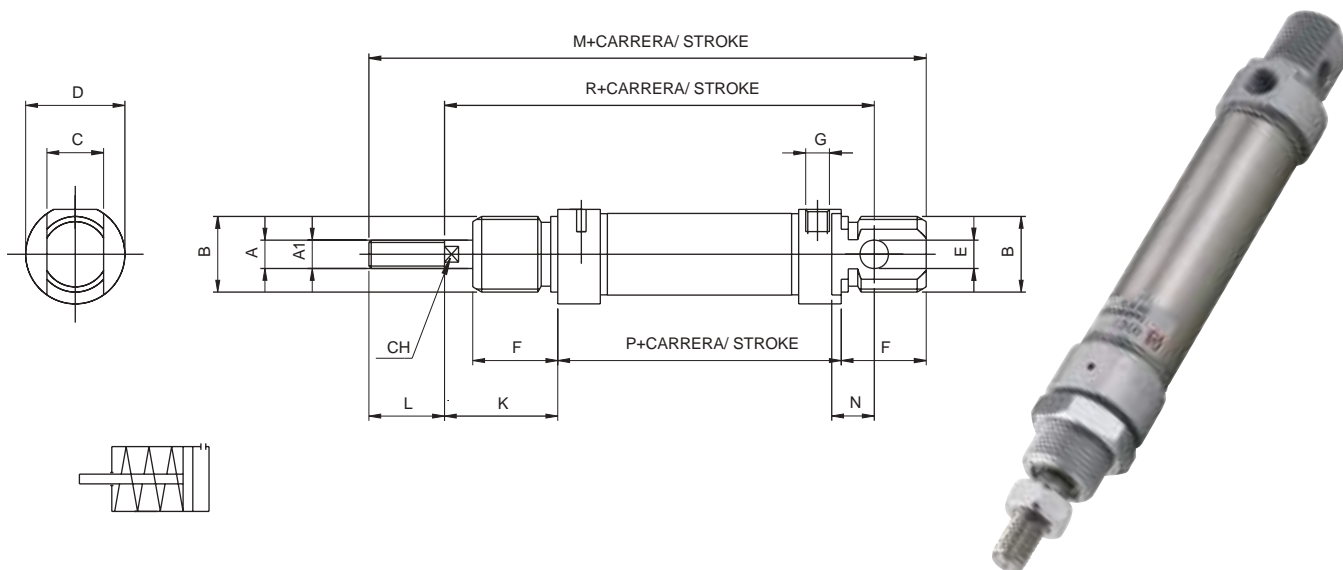

MB

SIMPLE EFECTO MAGNÉTICO - SINGLE-ACTING MAGNETIC

∅ mm.	A	A'	B	C	D	E	F	G	K	L	M	N	P	R	CH
8	M4	4	M12x1.25	8	16	4	12	M5	16	12	86	6	46	64	-
10	M4	4	M12x1,25	8	16	4	12	M5	16	12	86	6	46	64	-
12	M6	6	M16x1,5	12	19	6	18	M5	22	16	104	9	48	75	5
16	M6	6	M16x1,5	12	19	6	18	M5	22	16	109	9	53	82	5
20	M8	8	M22x1.5	16	27	8	20	1/8G	24	20	131	12	67	95	7
25	M10x1.25	10	M22x1.5	16	30	8	22	1/8G	28	22	140	12	68	104	9

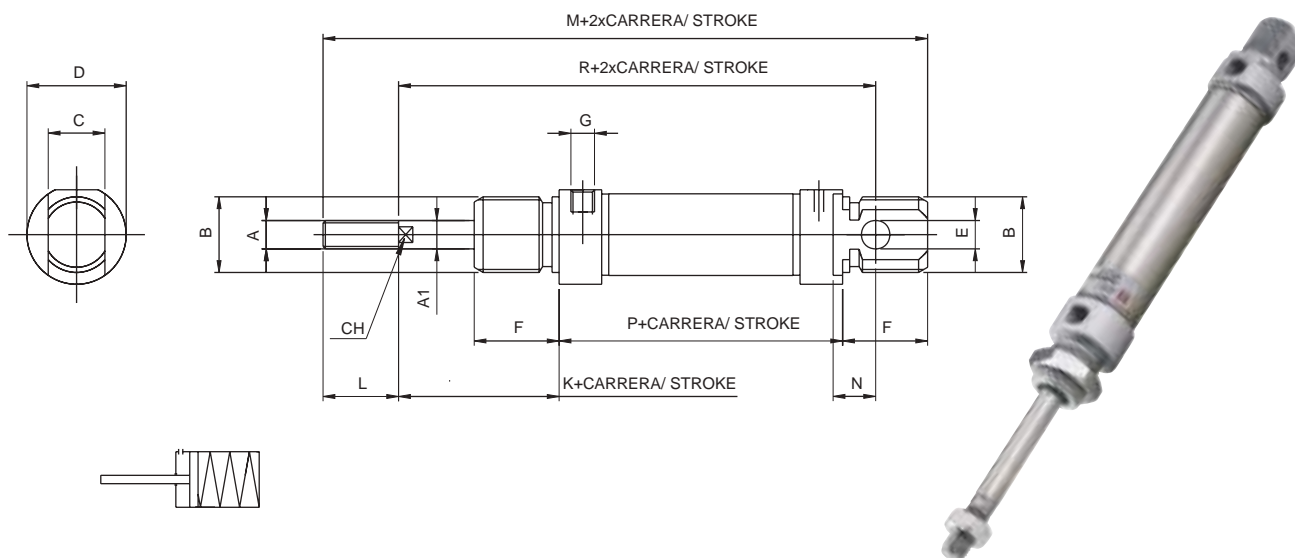

MD

SIMPLE EFECTO MAGNÉTICO - MUELLE EN EMPUJE - SINGLE-ACTING MAGNETIC - SPRING THRUST

∅ mm.	A	A'	B	C	D	E	F	G	K	L	M	N	P	R	CH
16	M6	6	M16x1.5	12	19	6	18	M5	22	16	134,5	9	78,5	107,5	5
20	M8	8	M22x1.5	16	27	8	20	1/8G	24	20	154	12	90	118	7
25	M10x1.25	10	M22x1.5	16	30	8	22	1/8G	28	22	166	12	94	130	9

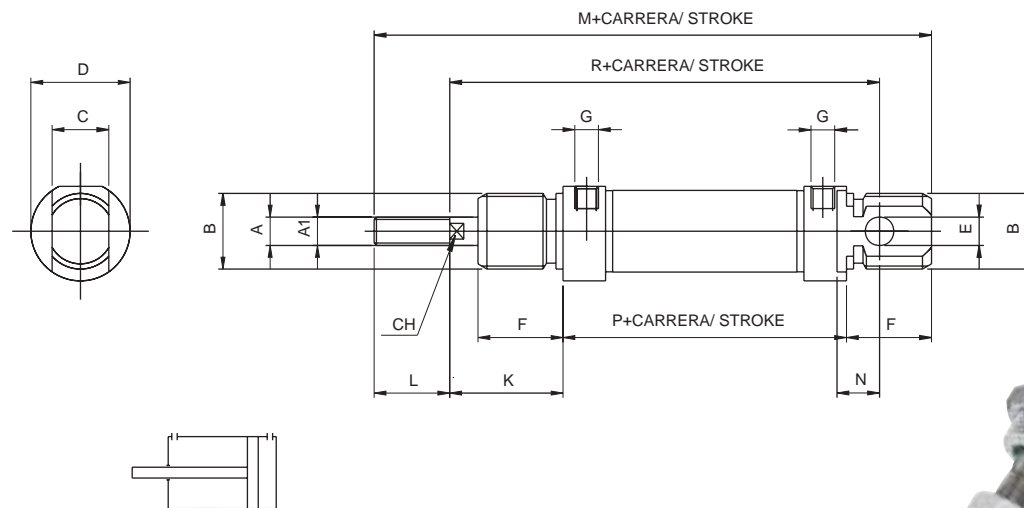

MF

DOBLE EFECTO MAGNÉTICO - DOUBLE ACTING MAGNETIC

Ø mm.	A	A1	B	C	D	E	F	G	K	L	M	N	P	R	CH
8	M4	4	M12x1.25	8	16	4	12	M5	16	12	86	6	46	64	-
10	M4	4	M12x1.25	8	16	4	12	M5	16	12	86	6	46	64	-
12	M6	6	M16x1.5	12	19	6	18	M5	22	16	104	9	48	75	5
16	M6	6	M16x1.5	12	19	6	18	M5	22	16	109	9	53	82	5
20	M8	8	M22x1.5	16	27	8	20	1/8G	24	20	131	12	67	95	7
25	M10x1.25	10	M22x1.5	16	30	8	22	1/8G	28	22	140	12	68	104	9

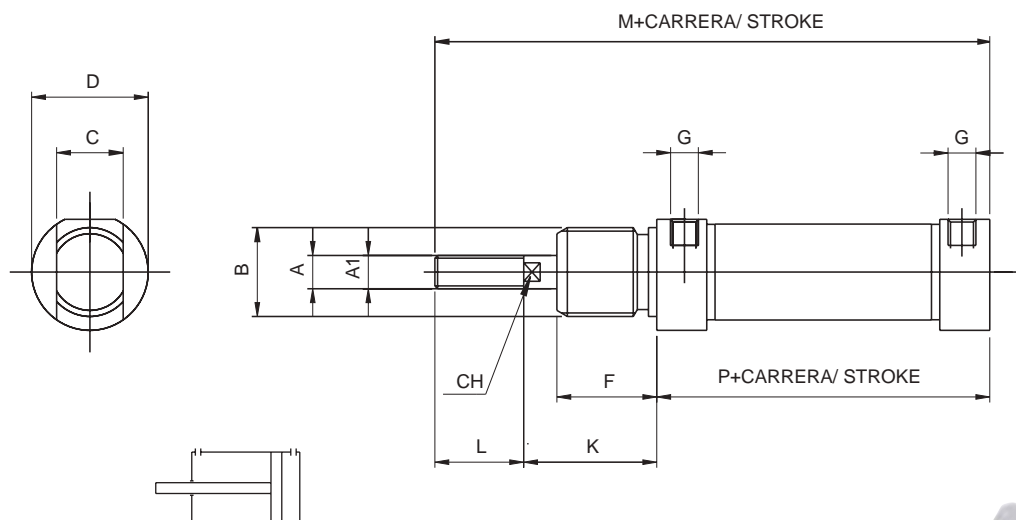

MFN

DOBLE EFECTO MAGNÉTICO TAPA TRONCA ALIMENTACIÓN 90° - DOUBLE ACTING MAGNETIC HEAD TCUT FEED AT 90 °

Ø mm.	A	A1	B	C	D	G	K	L	M	P
16	M6	6	M16x1.5	12	19	M5	22	16	109	53
20	M8	8	M22x1.5	16	27	1/8G	24	20	131	67
25	M10x1.25	10	M22x1.5	16	30	1/8G	28	22	140	68

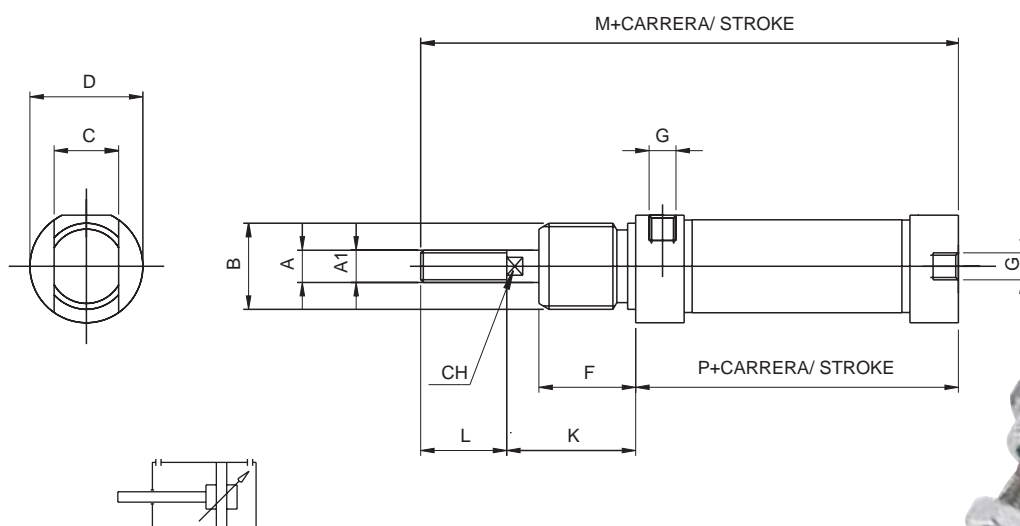

MFX

DOBLE EFECTO MAGNÉTICO TAPA TRONCA ALIMENTACIÓN AXIAL - DOUBLE ACTING MAGNETIC HEAD CUT FEED ON AXIS

∅ mm.	A	A'	B	C	D	G	K	L	M	P
16	M6	6	M16x1.5	12	21	M5	22	16	109	53
20	M8	8	M22x1.5	16	27	1/8G	24	20	131	67
25	M10x1.25	10	M22x1.5	16	30	1/8G	28	22	140	68

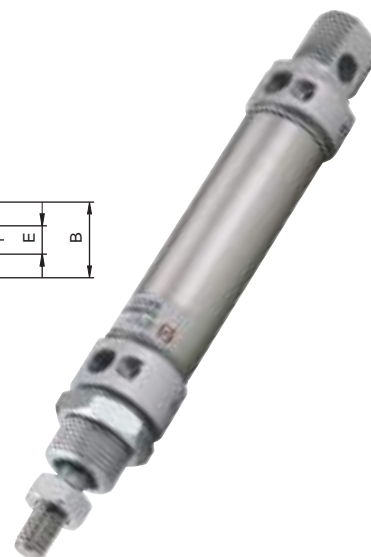
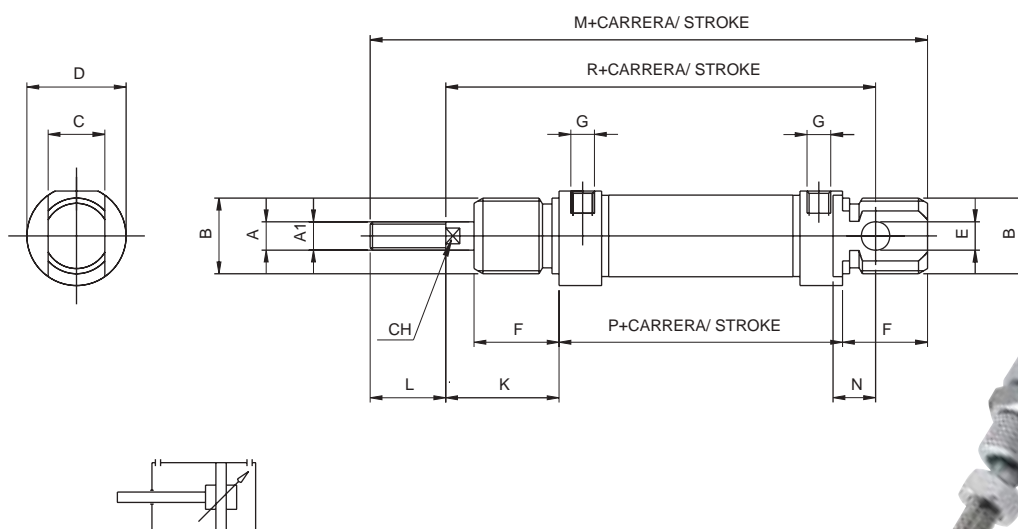

MH

DOBLE EFECTO AMORTIGUADO MAGNÉTICO - DOUBLE ACTING CUSHIONED MAGNETIC

∅ mm.	A	A'	B	C	D	E	F	G	K	L	M	N	P	R	CH
16	M6	6	M16x1.5	12	21	6	18	M5	22	16	109	9	53	8	25
20	M8	8	M22x1.5	16	27	8	20	1/8G	24	20	131	12	67	95	7
25	M10x1.25	10	M22x1.5	16	30	8	22	1/8G	28	22	140	12	68	104	9

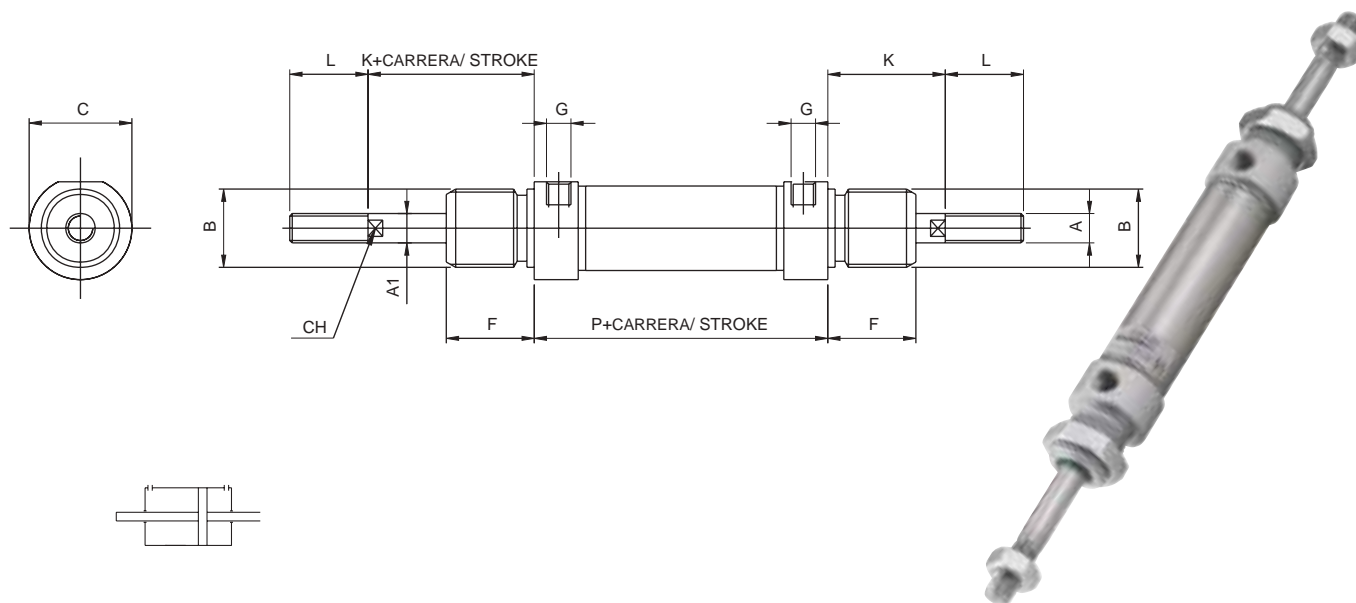

MJ

DOBLE EFECTO VÁSTAGO PASANTE MAGNÉTICO - DOUBLE ACTING MAGNETIC WITH DOUBLE ROD END

Ø mm.	A	A'	B	C	F	G	K	L	P	CH
16	M6	6	M16x1.5	19	18	M5	22	16	53	5
20	M8	8	M22x1.5	27	20	1/8G	24	20	67	7
25	M10x1.25	10	M22x1.5	30	22	1/8G	28	22	68	9

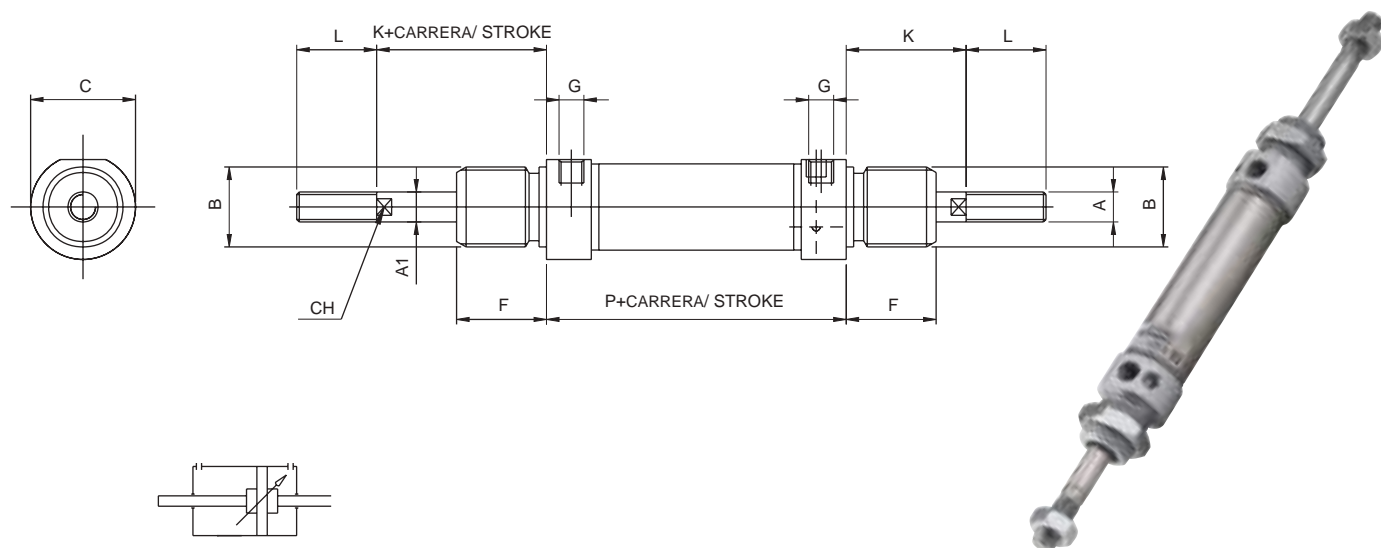

ML

DOBLE EFECTO VÁSTAGO PASANTE AMORTIGUADO MAGNÉTICO- DOUBLE ACTING CUSHIONED MAGNETIC WITH DOUBLE ROD END

Ø mm.	A	A'	B	C	F	G	K	L	P	CH
16	M6	6	M16x1.5	21	18	M5	22	16	53	5
20	M8	8	M22x1.5	27	20	1/8G	24	20	67	7
25	M10x1.25	10	M22x1.5	30	22	1/8G	28	22	68	9

Unidades de bloqueo para cilindros Iso 6432 / Piston Rod Lock for cylinders Iso 6432

La unidad de bloqueo sirve para inmovilizar el vástago en cualquier posición en caso de caída de la presión. En ausencia de alimentación neumática en el dispositivo de bloqueo, el vástago del cilindro es inmovilizado mecánicamente con una fuerza superior a la salida del cilindro alimentado a 10 bar. Es importante recordar que el vástago puede ser desbloqueado sólo cuando ambas cámaras están bajo presión.

The piston rod lock is a locking unit, which blocks the piston rod in any position in case of pressure drop. In case of lack of air to the locking device, the cylinder piston rod is mechanically blocked with a bigger force than the thrust made by the cylinder fed at 10 bar. It is important to remember that the locking unit of the piston rod can be released only when both the chambers are under pressure.



Características Técnicas / Technical Characteristics

Presiones / Pressures

Presión mínima de desbloqueo: 2.5 bar (0.25 Mpa) para presión cilindro de 0 a 7 bar (de 0 a 0.7 Mpa)
3 bar (0.3 Mpa) para presión cilindro de 7 a 10 bar (de 0.7 a 1 Mpa)

Minimum release pressure: 2.5 bar (0.25 Mpa) cylinder supply pressure from 0 to 7 bar (from 0 to 0.7 Mpa)
3 bar (0.3 Mpa) cylinder supply pressure from 7 to 10 bar (from 0.7 to 1 Mpa)

En ausencia de Presión / Without Pressures

Bloqueado / Locked

Temperaturas / Temperatures

Temperatura mínima / Minimum temperature: 0 °C
(-20 °C con aire seco / with dry air)
Temperatura máxima / Maximum temperature: +80 °C

Fluidos compatibles / Fluids

Aire comprimido filtrado lubricado y no lubricado
Filtered and lubricated compressed air as well as non lubricated air.

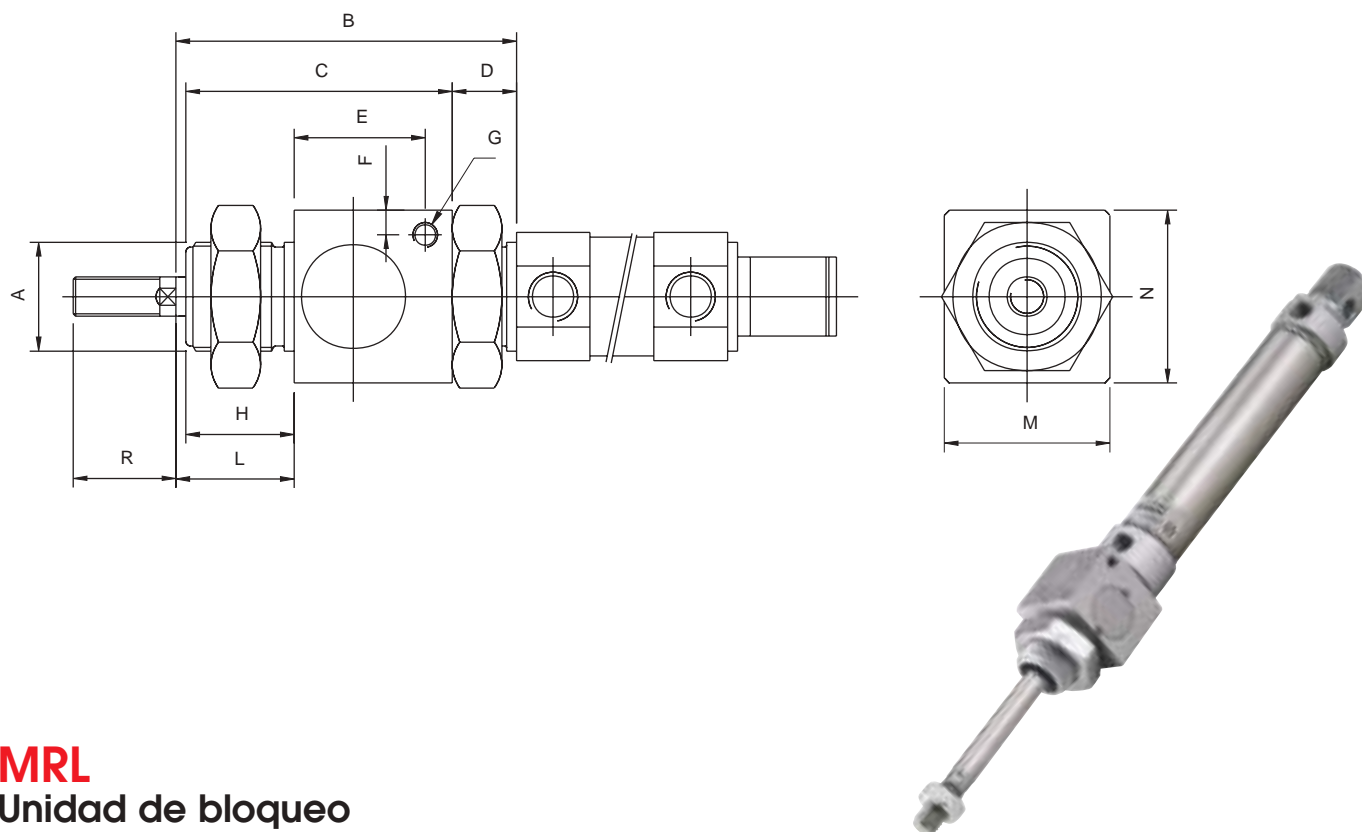

MRL Unidad de bloqueo

PISTON ROD LOCK

Ø mm.	A	B	C	D	E	F	G	H	L	M	N	R
20	M22x1.5	68.5	54	13	27	5	M5	22	23.5	34	35	23
25	M22x1.5	69.5	54	13	27	5	M5	22	24.5	34	35	26

Ejemplo de pedido / How to order

La unidad de bloqueo puede ser montada sólo sobre cilindro ISO 6432 Ø 20 o 25 con el vástago prolongado. Para identificar el cilindro con el vástago prolongado y unidad de bloqueo montada, es necesario añadir al código del cilindro la letra "B".

The piston rod lock can be assembled only with cylinders ISO 6432 Ø 20 or 25 mm produced with an extended piston rod. To identify the cylinder with extended piston rod and piston rod lock assembled, it is necessary to mention after the article code of the cylinder the letter "B".

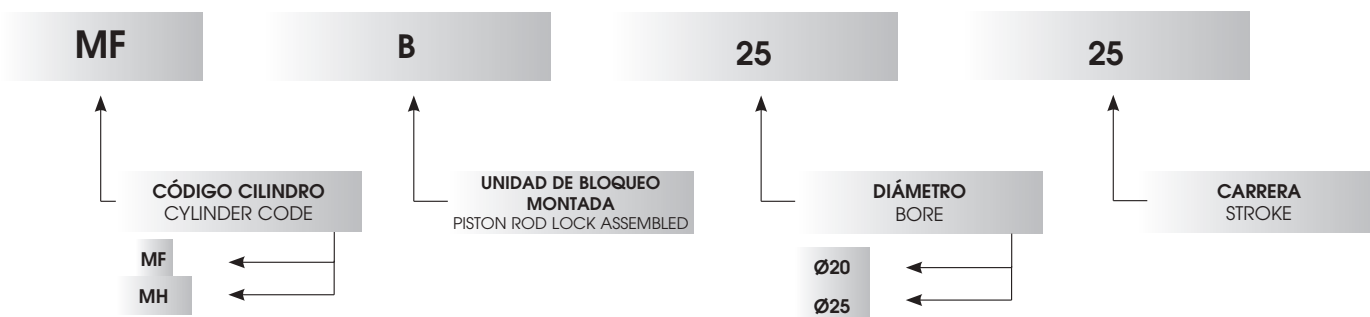

Componentes de fijación / Mounting Accessories



MFL

BRIDA - FLANGE

Ø mm.	A	B	C	R	S
8-10	12	3	30	9	4.5
12-16	16	4	40	13	5.5
20-25	22	5	50	19	6.6



MPD

PATA - FOOT

Ø mm.	A	B	C	D	G	H	J	R	S
8-10	12	4.5	35	25	11	16	16	10	3
12-16	16	5.5	42	32	14	20	20	13.5	4
20-25	22	6.6	54	40	17	25	25	18	5



MCC

CHARNELA- CLEVIS BRACKET

Ø mm.	B	B1	C	H	L	M	N	O	R	S
8-10	4.5	4	12.5	20	24	12.5	8.1	17	5	2.5
12-16	5.5	6	15	25	27	15	12.1	23	7	3
20-25	6.6	8	20	32	30	20	16.1	29.5	10	4

DA

TUERCA PARA TAPAS - NUT FOR COVERS

Cod.	Ø mm.	A	B	C
ODA000051D5ZI	8-10	M12x1.25	19	7
ODA000051E3ZI	12-16	M16x1.5	22	6
ODA000051F6ZI	20-25	M22x1.5	27	8



TUERCA PARA VÁSTAGO - NUT FOR RODS

Cod.	Ø mm.	A	B	C
ODA000051B1ZI	8-10	M4	7	3.2
ODA000051B8ZI	12-16	M6	10	5
ODA000051C3ZI	20	M8x1.25	13	6.5
ODA000051C9ZI	25	M10x1.25	17	8

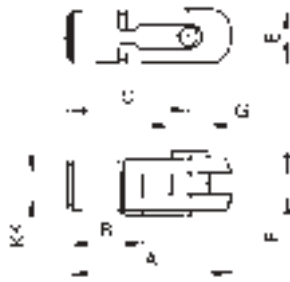

FC

HORQUILLA CON CLIPS EN ACERO ZINCADO - YOKE WITH LOCABLE PIN

Ø mm.	A	B	C	E	F	G	KK
8-10	21	8	16	8	4	4	M4
12-16	31	12	24	12	6	6	M6
20	42	16	32	16	8	8	M8
25 - 32	52	20	40	20	10	10	M10x1.25

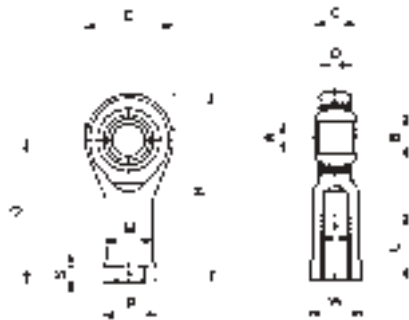

TF

RÓTULA AUTOLUBRICANTE- ROD ENDS SELF-LUBRIFICATING

Ø mm.	A	B	C	Ø	D	E	F	G	H	L	M	P	S	W	Carga radial		Peso
															Dinámica	Estática	
	H7	⁰	⁰ _{-0,13}	ESFERA	±0,13	±0,5		±0,5		±0,7	±0,7	±0,5	^{+0,2} _{-0,7}	±0,25	kg	kg	g
8-10	5	7,7	8	11,11	6	18	M4x0,7	27	36	10	9	11	4	9	-	-	-
12-16	6	8,9	9	12,7	6,75	20	M6x1	30	40	9	10	13	5	11	470	1.100	19
20	8	10,4	12	15,88	9	24	M8x1,25	36	48	12	12,5	16	5	14	780	1.900	36
25 - 32	10	12,9	14	19,05	10,5	28	M10x1,25	43	57	15	15	19	6,5	17	1.200	3.100	88

Minicilindros Inox / Mini Cylinders Inox

Los minicilindros INOX realizados según la norma ISO 6432, están particularmente preparados para su empleo en ambientes severos, corrosivos y de altas temperaturas. Por medio de una particular operación de montaje, denominada "double rolling" para unir las tapas con la camisa, la funcionalidad y la resistencia están garantizadas.

Bajo demanda: Juntas en FKM.

The cylinders included in this range can be used in any industrial fields where it is required a safety and constant functionality without particular maintenance. Mini cylinders are manufactured in conformity with standard ISO 6432. They are particularly suitable to be used in corrosive and high temperatures environments.

On request: FKM seals.



Características Técnicas / Technical Characteristics

Presiones / Pressures

Presión mínima / Minimum pressure: 2 bar (0.2 MPa)
Presión máxima / Maximum pressure: 10 bar (1 MPa)

Temperaturas / Temperatures

Temperatura mínima / Minimum temperature: 0 °C
 (-20 °C con aire seco / with dry air)
Temperatura máxima / Maximum temperature: +80 °C

Fluidos compatibles / Fluids

Aire comprimido filtrado lubricado y no lubricado
Filtered and lubricated compressed air as well as non lubricated air.

Funcionamiento / Functioning

Doble efecto magnético, Doble efecto no magnético.
Double-acting magnetic Double-acting without magnet.

Diámetros / Bores

16 - 20 - 25 mm.

Carreras / Strokes

Carreras Standard / Standard Strokes
De 10 a 320 mm / From 10 to 320 mm

Características Técnicas / Technical Characteristics

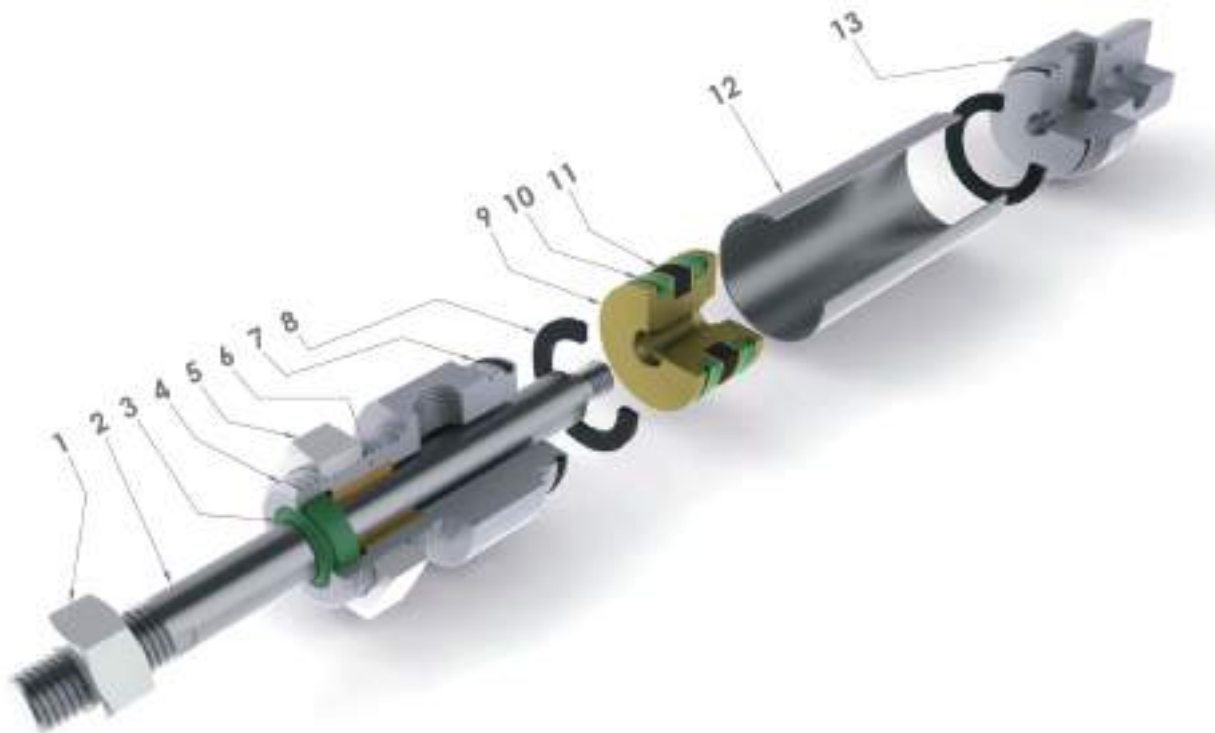

Materiales y Componentes / Component Parts and Materials

- | | |
|--|--|
| 1 Tuerca en acero AISI 304 | 1 Steel AISI 304 Nut |
| 2 Vástago en Acero AISI 316 | 2 Steel AISI 316 Piston rod |
| 3 Junta vástago en poliuretano | 3 Polyurethane Rod seal |
| 4 Tapa anterior en Acero AISI 304 | 4 Steel AISI 304 Front cover |
| 5 Tuerca en acero AISI 304 | 5 Steel AISI 304 Nut |
| 6 Cojinete en bronce sinterizado | 6 Sintered bronze Bearing |
| 7 Junta tórica en NBR | 7 NBR O-RING Seals |
| 8 Paragolpes en neopreno | 8 Neoprene Bumper |
| 9 Pistón en latón | 9 Brass Piston |
| 10 Junta pistón en poliuretano | 10 Polyurethane Piston seal |
| 11 Magnete en plastoferrita | 11 Plastroferrite Magnet |
| 12 Camisa minicilindro en acero AISI 304 | 12 Steel AISI 304 Mini cylinder shape body |
| 13 Tapa posterior en Acero AISI 304 | 13 Steel AISI 304 Back cover |

Fuerzas y Consumos / Forces And Consumptions

FUERZA DE EMPUJE Y TRACCIÓN - THRUST AND TRACTION FORCES

Ø Cilindro Ø Cylinder	Ø Vástago Ø Rod	Superficie útil en mm ² Working Surface in mm ²	Presión de trabajo en bar Operating pressure in bar									
			1	2	3	4	5	6	7	8	9	10
Ø16	6	Empuje / Thrust = 200 Tracción / Traction = 173	18	36	54	72	90	108	126	144	162	180
			16	32	48	64	80	96	112	128	144	160
Ø20	8	Empuje / Thrust = 314 Tracción / Traction = 264	28	56	84	112	140	168	196	224	252	280
			24	48	72	96	120	144	168	192	216	240
Ø25	10	Empuje / Thrust = 490 Tracción / Traction = 412	44	88	132	176	220	264	308	352	396	440
			36	72	108	144	180	216	252	288	324	360

CONSUMO CILINDRO - CYLINDER AIR CONSUMPTION

Ø Cilindro Ø Cylinder	Ø Vástago Ø Rod	Superficie útil en mm ² Working Surface in mm ²	Presión de trabajo en bar Operating pressure in bar									
			1	2	3	4	5	6	7	8	9	10
Consumo aire en NL para cada 10mm. de carrera Air consumption in NL for each 10mm. of stroke												
Ø16	6	Empuje / Thrust = 200	0,004	0,006	0,008	0,010	0,012	0,014	0,016	0,018	0,020	0,022
		Tracción / Traction = 173	0,003	0,005	0,007	0,009	0,010	0,012	0,014	0,016	0,017	0,019
Ø20	8	Empuje / Thrust = 314	0,006	0,009	0,013	0,016	0,019	0,022	0,025	0,028	0,031	0,035
		Tracción / Traction = 264	0,005	0,008	0,011	0,013	0,016	0,018	0,021	0,024	0,026	0,029
Ø25	10	Empuje / Thrust = 490	0,010	0,015	0,020	0,025	0,029	0,034	0,039	0,044	0,049	0,054
		Tracción / Traction = 412	0,008	0,012	0,016	0,021	0,025	0,029	0,033	0,037	0,041	0,045

Ejemplo de pedido / How to Order

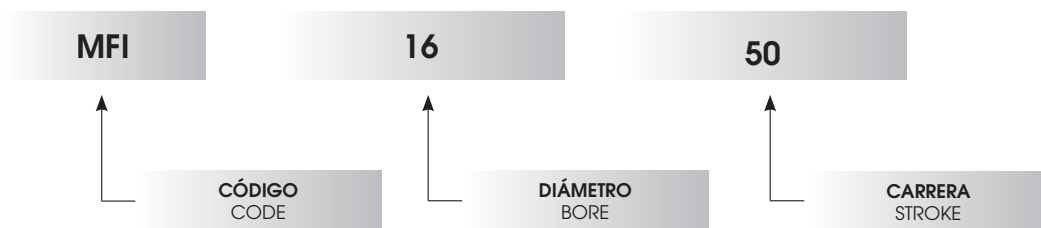

CARRERAS STANDARD mm. - STD STROKES

Ø mm.	10	25	50	80	100	125	160	200	250	320
16	●	●	●	●	●	●	●	●	●	●
20	●	●	●	●	●	●	●	●	●	●
25	●	●	●	●	●	●	●	●	●	●

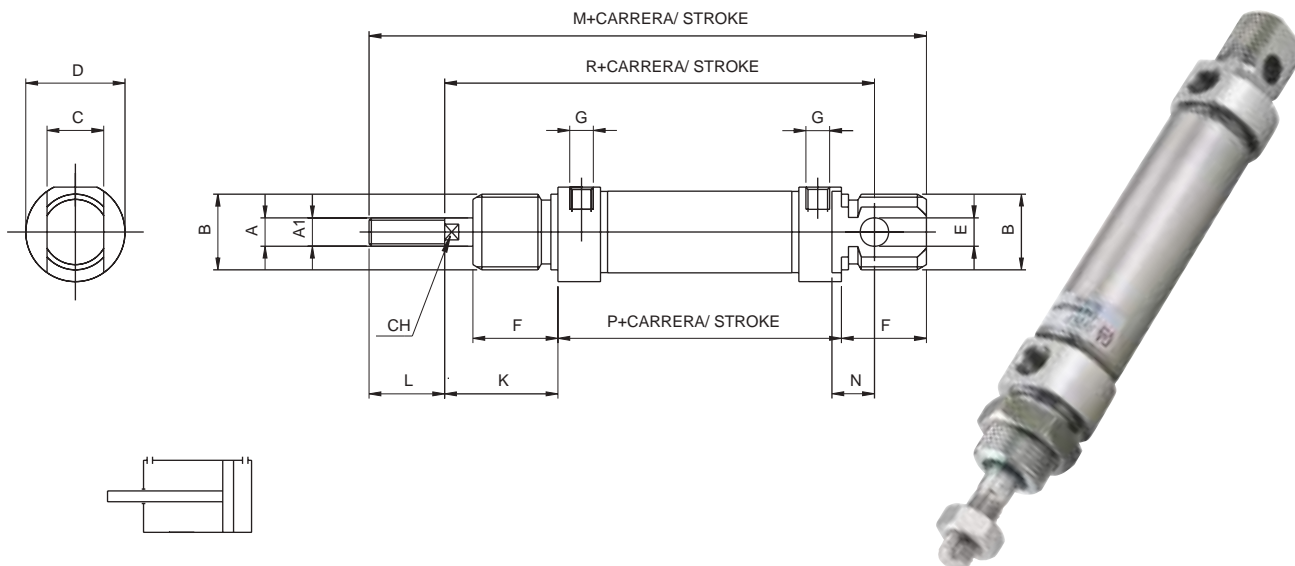

MFI

DOBLE EFECTO MAGNÉTICO INOX - DOUBLE ACTING MAGNETIC INOX

Ø mm.	A	A'	B	C	D	E	F	G	K	L	M	N	P	R	CH
16	M6	6	M16x1.5	12	19	6	18	M5	22	16	109	9	53	82	5
20	M8	8	M22x1.5	16	27	8	20	1/8G	24	20	131	12	67	95	7
25	M10x1.25	10	M22x1.5	16	30	8	22	1/8G	28	22	140	12	68	104	9

Componentes de fijación / Mounting Accessories



MFLI

BRIDA - FLANGE

Ø mm.	A	B	C	R	S
16	16	4	40	13	5.5
20-25	22	5	50	19	6.6



MPDI

PATA - FOOT

Ø mm.	A	B	C	D	G	H	J	R	S
16	16	5.5	42	32	14	20	20	13.5	4
20-25	22	6.6	54	43	17	25	25	18	5



MCCI

CHARNELA - CLEVIS BRACKET

Ø mm.	B	B1	C	H	L	M	N	O	R	S
16	5.5	6	15	25	27	15	12.1	23	7	3
20-25	6.6	8	20	32	30	20	16.1	29.5	10	4

DAI

TUERCA PARA TAPAS - NUT FOR COVERS

Cod.	Ø mm.	A	B	C
0DA000043E300	16	M16x1.5	22	6
0DA000043F600	20-25	M22x1.5	27	8



TUERCA PARA VÁSTAGO - NUT FOR RODS

Cod.	Ø mm.	A	B	C
0DA000043B800	16	M6	10	5
0DA000043C300	20	M8x1.25	13	6.5
0DA000043C900	25	M10x1.25	17	8

Cilindros A95 / Cylinders A95

Los cilindros A95 están realizados con perfil pulido, lineal, y en conjunto, con unas dimensiones reducidas, particularmente adaptados para su utilización en espacios reducidos. Por medio de una particular operación de montaje, denominada "double rolling" para unir las tapas con la camisa, la funcionalidad y la resistencia están garantizadas.

The cylinders A95 manufactured with a clean, linear profile and reduced overall dimensions are particularly suitable to be used in reduced spaces. By using a special assembling operation called "double rolling" to join the end covers to the barrel, functionality and resistance are ensured.



Características Técnicas / Technical Characteristics

Presiones / Pressures

Presión mínima / Minimum pressure: 1 bar (0.1 MPa)
Presión máxima / Maximum pressure: 10 bar (1 MPa)

Temperaturas / Temperatures

Temperatura mínima / Minimum temperature: 0 °C
 (-20 °C con aire seco / with dry air)
Temperatura máxima / Maximum temperature: +80 °C

Fluidos compatibles / Fluids

Aire comprimido filtrado lubricado y no lubricado
Filtered and lubricated compressed air as well as non lubricated air.

Funcionamiento / Functioning

Simple y doble efecto amortiguado Magnético y no Magnético, Vástago simple o pasante.
Single and Double-acting cushioned Magnetic and non-Magnetic, Single or through piston rod

Diámetros / Bores

32 - 40 - 50 - 63 mm.

Carreras / Strokes

Carreras Standard / Standard Strokes
De 10 a 500 mm / From 10 to 500 mm

Características Técnicas / Technical Characteristics

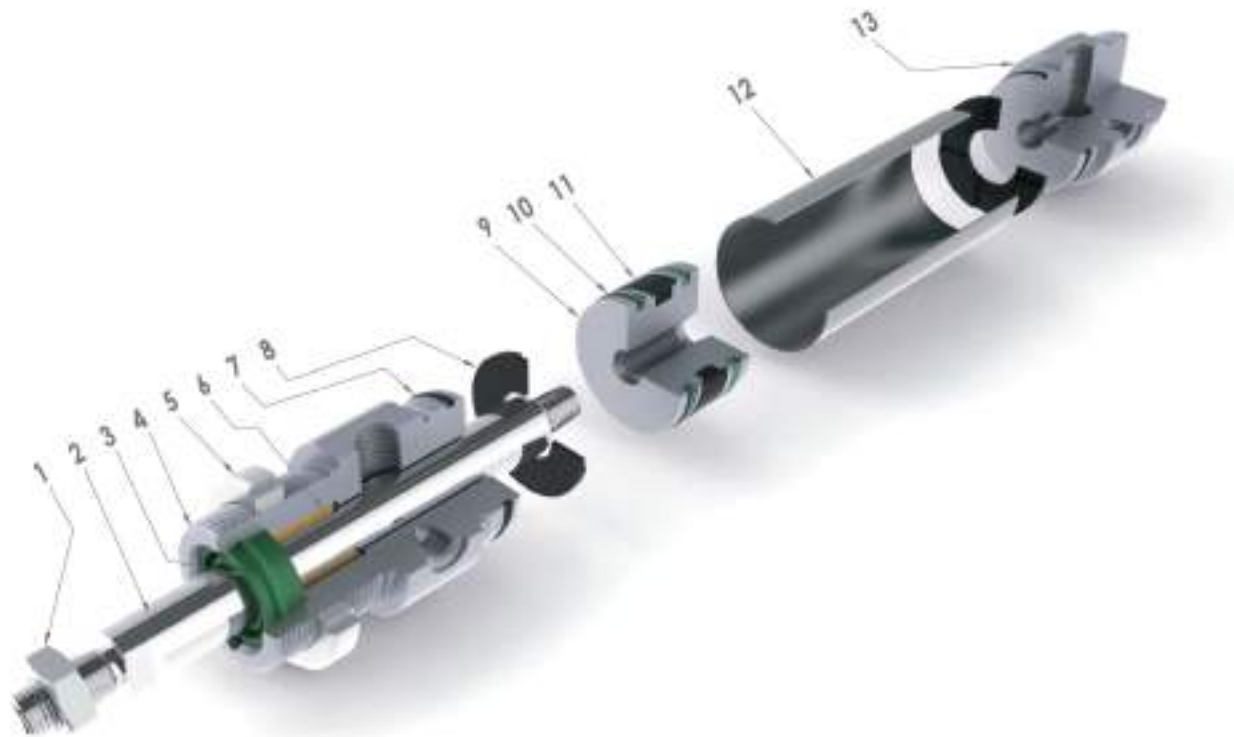

Materiales y Componentes / Component Parts and Materials

- | | |
|---|---------------------------------------|
| 1 Tuerca en acero zincado | 1 Zinc-plated steel Nut |
| 2 Vástago pistón acero C40 cromado | 2 Chrome steel C40 Piston rod |
| 3 Junta vástago en poliuretano | 3 Polyurethane Rod seal |
| 4 Tapa anterior en aluminio anodizado | 4 Anodised aluminium Front cover |
| 5 Tuerca tapa en acero zincado | 5 Zinc-plated steel Nut |
| 6 Cojinete en bronce sinterizado | 6 Sintered bronze Bearing |
| 7 Junta tórica en NBR | 7 NBR O-RING Seals |
| 8 Paragolpes en neopreno | 8 Neoprene Bumper |
| 9 Pistón en aluminio anodizado | 9 Anodised aluminium Piston |
| 10 Junta pistón en poliuretano | 10 Polyurethane Piston Seal |
| 11 Magnete en plastoferrita | 11 Bonded ferrite Magnet |
| 12 Camisa cilindro en acero AISI 304 | 12 Steel AISI 304 Cylinder shape body |
| 13 Tapa posterior en aluminio anodizado | 13 Anodised aluminium Back cover |

Fuerzas y Consumos / Forces And Consumptions

FUERZA DE EMPUJE Y TRACCIÓN - THRUST AND TRACTION FORCES

Ø Cilindro / Ø Cylinder	Ø Vástago / Ø Rod	Superficie útil en mm ² / Working Surface in mm ²	Presión de trabajo en bar / Operating pressure in bar									
			1	2	3	4	5	6	7	8	9	10
			Fuerza desarrollada en N / Output force in N									
Ø32	12	Empuje / Thrust = 804	72	144	216	288	360	432	504	576	648	720
		Tracción / Traction = 691	62	124	186	248	310	372	434	496	558	620
Ø40	16	Empuje / Thrust = 1257	110	220	330	440	550	660	770	880	990	1100
		Tracción / Traction = 1056	95	190	285	380	475	570	665	760	855	950
Ø50	20	Empuje / Thrust = 1963	175	350	525	700	875	1050	1225	1400	1575	1750
		Tracción / Traction = 1649	148	296	444	592	740	888	1036	1184	1332	1480
Ø63	20	Empuje / Thrust = 3117	280	560	840	1120	1400	1680	1960	2240	2520	2800
		Tracción / Traction = 2803	250	500	750	1000	1250	1500	1750	2000	2250	2500

FUERZA DEL MUELLE - SPRING TRACTION FORCES

Ø Cilindro Ø Cylinder	Carga Muelle Load Spring	Carrera / Stroke		
		10	25	50
		Fuerza desarrollada en N Output force in N		
Ø32	Carga Muelle en Reposo / Load of spring at rest	56	51	42
	Carga Muelle Comprimido / Load of compressed spring	60	60	60
Ø40	Carga Muelle en Reposo / Load of spring at rest	60	55	44
	Carga Muelle Comprimido / Load of compressed spring	65	65	65
Ø50	Carga Muelle en Reposo / Load of spring at rest	64	57	46
	Carga Muelle Comprimido / Load of compressed spring	68	68	68
Ø63	Carga Muelle en Reposo / Load of spring at rest	65	58	47
	Carga Muelle Comprimido / Load of compressed spring	70	70	70

CONSUMO CILINDRO - CYLINDER AIR CONSUMPTION

Ø Cilindro Ø Cylinder	Ø Vástago Ø Rod	Superficie útil en mm ² Working Surface in mm ²	Presión de trabajo en bar Operating pressure in bar									
			1	2	3	4	5	6	7	8	9	10
			Consumo aire en NL para cada 10mm. de carrera Air consumption in NL for each 10mm. of stroke									
Ø32	12	Empuje / Thrust = 804	0,016	0,024	0,032	0,040	0,048	0,056	0,064	0,072	0,080	0,088
		Tracción / Traction = 691	0,014	0,021	0,028	0,035	0,041	0,048	0,055	0,062	0,069	0,076
Ø40	16	Empuje / Thrust = 1257	0,025	0,038	0,050	0,063	0,075	0,088	0,101	0,113	0,126	0,138
		Tracción / Traction = 1056	0,021	0,032	0,042	0,053	0,063	0,074	0,084	0,095	0,106	0,116
Ø50	20	Empuje / Thrust = 1963	0,039	0,059	0,079	0,098	0,118	0,137	0,157	0,177	0,196	0,216
		Tracción / Traction = 1649	0,033	0,049	0,066	0,082	0,099	0,115	0,132	0,148	0,165	0,181
Ø63	20	Empuje / Thrust = 3117	0,062	0,094	0,125	0,156	0,187	0,218	0,249	0,281	0,312	0,343
		Tracción / Traction = 2803	0,056	0,084	0,112	0,140	0,168	0,196	0,224	0,252	0,280	0,308

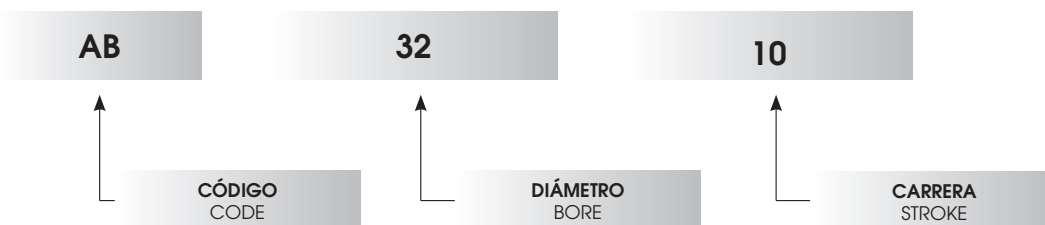
Ejemplo de pedido / How to Order

CARRERAS STANDARD mm. - STD STROKES

Ø mm.	10	25	50	80	100	125	160	200	250	320	400	500
32	▲■●	▲■◆●	▲■◆●	◆●	◆●	◆●	◆●	◆●	◆●	◆●	◆●	◆●
40	▲■●	▲■◆●	▲■◆●	◆●	◆●	◆●	◆●	◆●	◆●	◆●	◆●	◆●
50	▲■●	▲■◆●	▲■◆●	◆●	◆●	◆●	◆●	◆●	◆●	◆●	◆●	◆●
63	▲■●	▲■◆●	▲■◆●	◆●	◆●	◆●	◆●	◆●	◆●	◆●	◆●	◆●

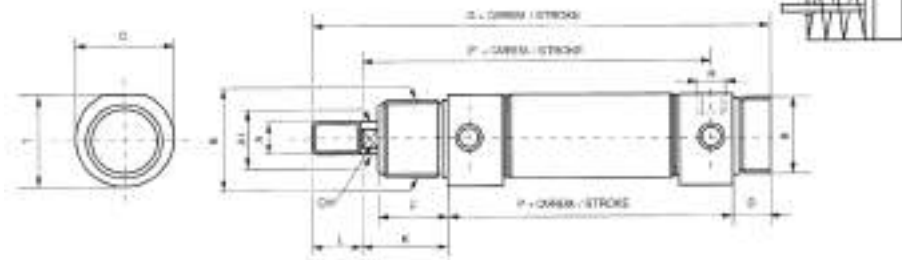
- ▲ **AB** SIMPLE EFECTO MAGNÉTICO - SINGLE-ACTING MAGNETIC
- **AD** SIMPLE EFECTO MAGNÉTICO - MUELLE EN EMPUJE - SINGLE-ACTING MAGNETIC - SPRING THRUST
- **AF** DOBLE EFECTO MAGNÉTICO - DOUBLE ACTING MAGNETIC
- ◆ **AH** DOBLE EFECTO AMORTIGUADO MAGNÉTICO - DOUBLE ACTING CUSHIONED MAGNETIC
- **AJ** DOBLE EFECTO VÁSTAGO PASANTE MAGNÉTICO - DOUBLE ACTING MAGNETIC WITH DOUBLE ROD END
- ◆ **AL** DOBLE EFECTO VÁSTAGO PASANTE AMORTIGUADO MAGNÉTICO
DOUBLE ACTING CUSHIONED MAGNETIC WITH DOUBLE ROD END



AB SIMPLE EFECTO MAGNÉTICO - SINGLE-ACTING MAGNETIC

Ø mm.	A	A'	B	T	C	D	F	G	K	L	P	P'	CH	R
32	M10x1.25	12	M30x1.5	36.5	38	14	30	168	38	20	96	125	10	1/8" GAS
40	M12x1.25	16	M38x1.5	44	46	16	35	196	45	24	111	144	12	1/4" GAS
50	M16x1.5	20	M45x1.5	55	57	18	38	220	50	32	120	158	16	1/4" GAS
63	M16x1.5	20	M45x1.5	67.5	70	18	38	224	50	32	124	161	16	3/8" GAS

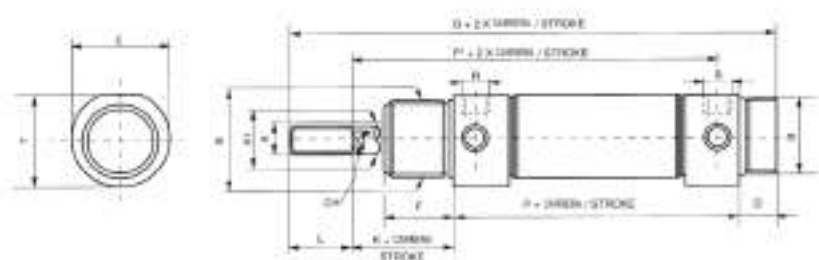

AD SIMPLE EFECTO MAGNÉTICO - MUELLE EN EMPUJE - SINGLE-ACTING MAGNETIC - SPRING THRUST

Ø mm.	A	A'	B	T	C	D	F	G	K	L	P	P'	CH	R
32	M10x1.25	12	M30x1.5	36.5	38	14	30	168	38	20	96	125	10	1/8" GAS
40	M12x1.25	16	M38x1.5	44	46	16	35	196	45	24	111	144	12	1/4" GAS
50	M16x1.5	20	M45x1.5	55	57	18	38	220	50	32	120	158	16	1/4" GAS
63	M16x1.5	20	M45x1.5	67.5	70	18	38	224	50	32	124	161	16	3/8" GAS

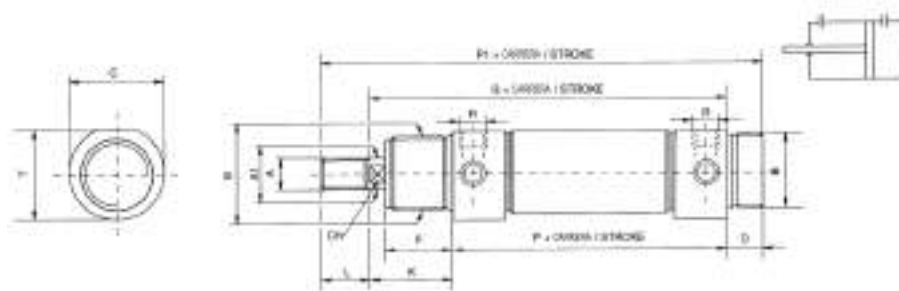

AF

DOBLE EFECTO MAGNÉTICO - DOUBLE ACTING MAGNETIC

Ø mm.	A	A'	B	T	C	D	F	G	K	L	P	PI	CH	R
32	M10x1.25	12	M30x1.5	36.5	38	14	30	134	38	20	96	168	10	1/8"GAS
40	M12x1.25	16	M38x1.5	44	46	16	35	156	45	24	111	196	12	1/4"GAS
50	M16x1.5	20	M45x1.5	55	57	18	38	170	50	32	120	220	16	1/4"GAS
63	M16x1.5	20	M45x1.5	67.5	70	18	38	174	50	32	124	224	16	3/8"GAS

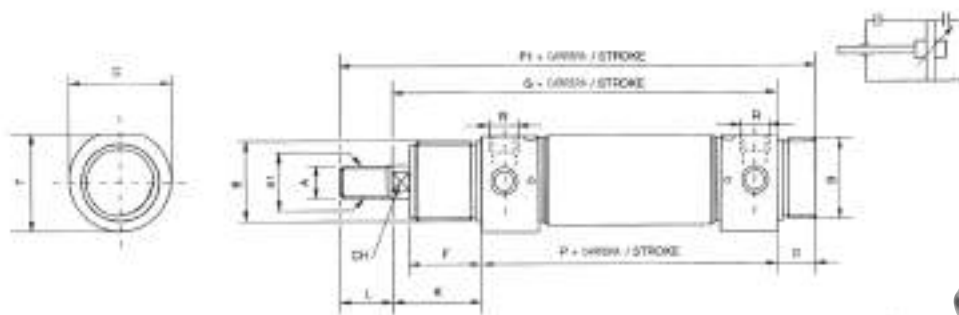

AH

DOBLE EFECTO AMORTIGUADO MAGNÉTICO - DOUBLE ACTING CUSHIONED MAGNETIC

Ø mm.	A	A'	B	T	C	D	F	G	K	L	P	PI	CH	R
32	M10x1.25	12	M30x1.5	36.5	38	14	30	134	38	20	96	168	10	1/8"GAS
40	M12x1.25	16	M38x1.5	44	46	16	35	156	45	24	111	196	12	1/4"GAS
50	M16x1.5	20	M45x1.5	55	57	18	38	170	50	32	120	220	16	1/4"GAS
63	M16x1.5	20	M45x1.5	67.5	70	18	38	174	50	32	124	224	16	3/8"GAS

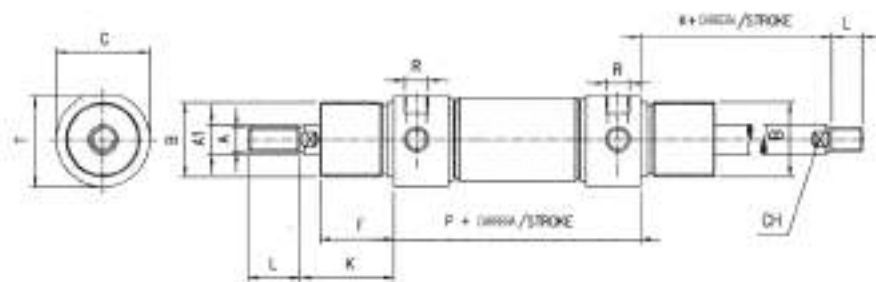

AJ

DOBLE EFECTO VÁSTAGO PASANTE MAGNÉTICO - DOUBLE ACTING MAGNETIC WITH DOUBLE ROD END

Ø mm.	A	A'	B	T	C	F	K	L	P	CH	R
32	M10x1.25	12	M30x1.5	36.5	38	30	38	20	96	10	1/8G
40	M12x1.25	16	M38x1.5	44	46	35	45	24	111	12	1/4G
50	M16x1.5	20	M45x1.5	55	57	38	50	32	120	16	1/4G
63	M16x1.5	20	M45x1.5	67.5	70	38	50	32	124	16	3/8G



AL

DOBLE EFECTO VÁSTAGO PASANTE AMORTIGUADO MAGNÉTICO - DOUBLE ACTING CUSHIONED MAGNETIC WITH DOUBLE ROD END

Ø mm.	A	A'	B	T	C	F	K	L	P	CH	R
32	M10x1.25	12	M30x1.5	36.5	38	30	38	20	96	10	1/8G
40	M12x1.25	16	M38x1.5	44	46	35	45	24	111	12	1/4G
50	M16x1.5	20	M45x1.5	55	57	38	50	32	120	16	1/4G
63	M16x1.5	20	M45x1.5	67.5	70	38	50	32	124	16	3/8G

Componentes de fijación / Mounting Accessories

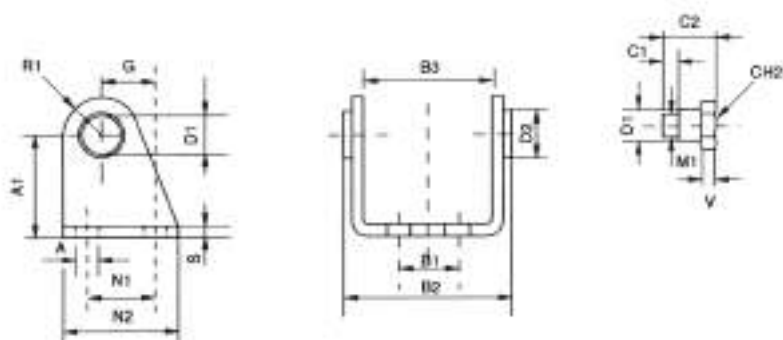

ACC

KIT CHARNELA CON TORNILLOS DE FIJACIÓN - CLEVIS BRACKET

∅ mm.	D1	D2	A	A1	G	M1	N1	N2	R1	S	CH2	B1	B2	B3	V	C1	C2
32	10	16	7	35	20	M8x1	24	40	12	4	13	20	50.1	38.1	4	6	18
40	12	18	9	40	27	M10x1	30	50	13	5	17	28	60.1	46.1	5	7	21.6
50	14	23	9	45	30	M12x1.5	34	54	14	6	19	36	74.1	57.1	6	9	26.4
63	16	24	9	50	34	M14x1.5	35	65	16	6	19	42	88.1	70.1	6	15	34

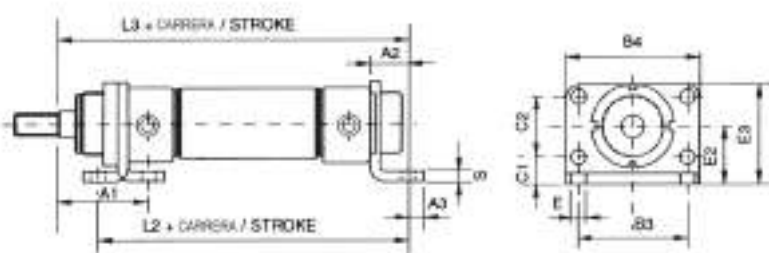

APD

PATA - FOOT FLANGE

∅ mm.	E	E2	E3	C1	C2	L2	L3	B3	B4	S	A1	A2	A3
32	7	28	49	14	28	124	148	52	66	4	48	14	7
40	9	33	58	18	30	151	176	60	80	5	60	20	10
50	9	40	70	20	40	160	190	70	90	6	64	20	10
63	9	45	80	20	50	164	194	76	96	6	65	20	10

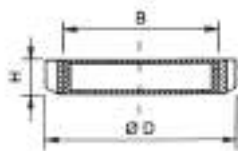

AGT

TUERCA TAPAS - NUT

∅ mm.	B	D	H
32	M30x1.5	45	7
40	M38x1.5	50	8
50 - 63	M45x1.5	58	9

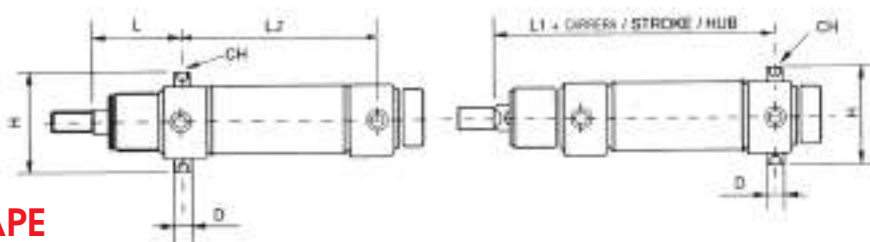

APE

FIJACIÓN CON 2 PERNOS - PIVOT

Ø mm.	D	H	L1	L2	L	CH
32	10	51	125	78	47	5
40	12	61	144	87	57	6
50	14	75	158	96	62	6
63	16	90	161	98	63	8

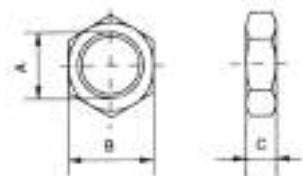

DA

TUERCA PARA VÁSTAGO - NUT FOR RODS

Cod.	Ø mm.	A	B	C
0DA000051C9ZI	32	M10x1.25	17	8
0DA000051D5ZI	40	M12x1.25	19	7
0DA000051E3ZI	50 - 63	M16x1.5	22	6



FC

HORQUILLA CON CLIPS EN ACERO ZINCADO - YOKE WITH LOCABLE PIN

Ø mm.	A	B	C	E	F	G	KK
25 - 32	52	20	40	20	10	10	M10x1.25
40	62	24	48	24	12	12	M12x1.25
50-63	83	32	64	32	16	16	M16x1.5

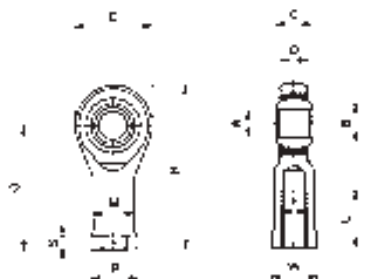

TF

RÓTULA AUTOLUBRICANTE - ROD ENDS SELF-LUBRIFICATING

Ø mm.	A	B	C	Ø	D	E	F	G	H	L	M	P	S	W	Carga radial		Peso
															Dinámico	Estático	
	H7	0	0	ESFERA	±0,13	±0,5		±0,5		±0,7	±0,7	±0,5	+0,2 -0,7	±0,25	kg	kg	g
25 - 32	10	12,9	14	19,05	11,5	30	M10x1.25	43	58	15	15	19	6,5	16	1.200	3.100	88
40	12	15,4	16	22,23	12,5	34	M12x1.25	50	67	18	17,5	22	6,5	18	1.400	3.700	120
50-63	16	19,3	21	28,58	15,5	42	M16x1.5	64	85	24	22	27	8	24	2.500	6.300	240

Cilindros Compactos / Compact Cylinders

Los cilindros compactos han sido realizados un 50% más reducidos en tamaño respecto a un cilindro de norma y fuerza equivalente, la particular estructura constructiva ofrece una buena resistencia axial. El nuevo diseño ha sido dotado por tres lados de unas guías en las cuales es posible adaptarse sensores magnéticos y amortiguaciones elásticas al final de la carrera. Las distancias fijadas entre los centros del cilindro de diámetro 20 hasta 100 mm están diseñadas conforme al estándar UNITOP.

The overall dimensions of these compact cylinders are 50% smaller compared to a classic equivalent cylinder; the particular manufacturing structure ensures a good axial resistance. The new innovative design has been equipped on three sides with guides on whom it is possible to assembly the disappearance switches and elastic bumpers at the stroke end. The fixing distances between cylinder's centers from diameter 20 to 100 mm are in conformity with the standard UNITOP.



Características Técnicas / Technical Characteristics

Presiones / Pressures

Presión mínima / Minimum pressure: 1 bar (0.1 MPa)
Presión máxima / Maximum pressure: 10 bar (1 MPa)

Temperaturas / Temperatures

Temperatura mínima / Minimum temperature: 0 °C
 (-20 °C con aire seco / with dry air)
Temperatura máxima / Maximum temperature: +80 °C

Fluidos compatibles / Fluids

Aire comprimido filtrado lubricado y no lubricado
 Filtered and lubricated compressed air as well as non lubricated air.

Funcionamiento / Functioning

Simple efecto magnético, Doble efecto magnético
Vástago simple o pasante magnético, Antirotación magnético.
 Single and Double-acting magnetic, Single or through piston rod magnetic Antirotation magnetic.

Diámetros / Bores

De 12 a 100 mm / From 10 to 100 mm

Carreras / Strokes

Carreras Standard / Standard Strokes
De 5 a 80 mm / From 5 to 80 mm

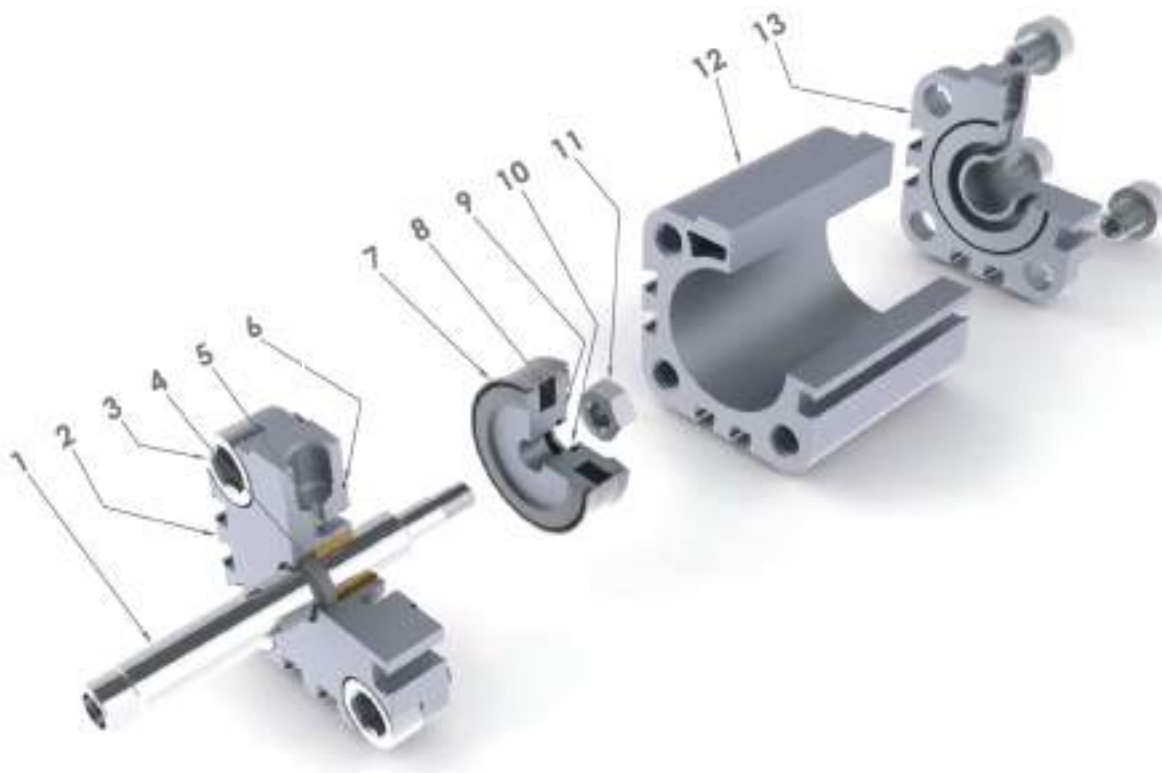
Características Técnicas / Technical Characteristics

Materiales y Componentes / Component Parts and Materials

- | | |
|---|---|
| 1 Vástago pistón acero cromado
(AISI 303 de 12 a 25) (C40 de 32 a 100) | 1 Chrome steel Piston rod
(AISI 303 from 12 to 25)(C40 from 32 to 100) |
| 2 Tapa anterior en aluminio anodizado | 2 Anodised aluminium Front cover |
| 3 Tornillos en acero zincado | 3 Zinc-plated steel Screw |
| 4 Junta vástago en poliuretano | 4 Polyurethane Rod Seal |
| 5 Cojinete en bronce sinterizado | 5 Sintered bronze Bearing |
| 6 Junta tórica en NBR | 6 NBR O-RING Seals |
| 7 Junta pistón en poliuretano | 7 Polyurethane Piston Seal |
| 8 Magnete en plastoferrita | 8 Bonded ferrite Magnet |
| 9 Pistón en aluminio | 9 Aluminium Piston |
| 10 Junta tórica en NBR | 10 NBR O-RING Seals |
| 11 Tuerca fijación pistón en acero zincado | 11 Zinc-plated steel Piston nut |
| 12 Camisa cilindro en aluminio anodizado | 12 Anodised aluminium Cylinder shape body |
| 13 Tapa posterior en aluminio anodizado | 13 Anodised aluminium Back cover |

Fuerzas y Consumos / Forces And Consumptions

FUERZA DE EMPUJE Y TRACCIÓN - THRUST AND TRACTION FORCES

Ø Cilindro Ø Cylinder	Ø Vástago Ø Rod	Superficie útil en mm2 Working Surface in mm2	Presión de trabajo en bar Operating pressure in bar									
			1	2	3	4	5	6	7	8	9	10
			Fuerza desarrollada en N Output force in N									
Ø12	6	Empuje / Thrust = 113	10	20	30	40	50	60	70	80	90	100
		Tracción / Traction = 85	7,5	15	22	30	37	45	52	60	68	75
Ø16	8	Empuje / Thrust = 200	18	35	53	70	90	105	125	145	160	180
		Tracción / Traction = 150	13	26	40	53	65	80	95	105	120	130
Ø20	10	Empuje / Thrust = 314	28	55	85	110	140	170	195	220	250	280
		Tracción / Traction = 235	21	42	60	85	105	125	150	170	190	210
Ø25	10	Empuje / Thrust = 490	44	88	132	176	220	264	308	352	396	440
		Tracción / Traction = 412	36	72	108	144	180	216	252	288	324	360
Ø32	12	Empuje / Thrust = 804	72	144	216	288	360	432	504	576	648	720
		Tracción / Traction = 691	62	124	186	248	310	372	434	496	558	620
Ø40	12	Empuje / Thrust = 1257	110	220	330	440	550	660	770	880	990	1100
		Tracción / Traction = 1144	100	200	300	400	500	600	700	800	900	1000
Ø50	16	Empuje / Thrust = 1963	175	350	525	700	875	1050	1225	1400	1575	1750
		Tracción / Traction = 1762	155	310	465	620	775	930	1085	1240	1395	1550
Ø63	16	Empuje / Thrust = 3117	280	560	840	1120	1400	1680	1960	2240	2520	2800
		Tracción / Traction = 2916	260	520	780	1040	1300	1560	1820	2080	2340	2600
Ø80	20	Empuje / Thrust = 5027	450	900	1350	1800	2250	2700	3150	3600	4050	4500
		Tracción / Traction = 4712	420	840	1260	1680	2100	2520	2940	3360	3780	4200
Ø100	25	Empuje / Thrust = 7854	700	1400	2100	2800	3500	4200	4900	5650	6360	7000
		Tracción / Traction = 7363	660	1320	1980	2640	3300	3960	4620	5280	5940	6600

FUERZA DEL MUELLE - SPRING TRACTION FORCES

Ø Cilindro Ø Cylinder	Carga Muelle Load Spring	Carrera / Stroke				
		5	10	15	20	25
		Fuerza desarrollada en N Output force in N				
Ø12	Carga Muelle en Reposo / Load of spring at rest	7,5	6,8			
	Carga Muelle Comprimido / Load of compressed spring	8	8			
Ø16	Carga Muelle en Reposo / Load of spring at rest	12,3	10,8	9,5	7,8	6,5
	Carga Muelle Comprimido / Load of compressed spring	13,3	13,3	13,3	13,3	13,3
Ø20	Carga Muelle en Reposo / Load of spring at rest	15,7	14	12,2	10,4	8,7
	Carga Muelle Comprimido / Load of compressed spring	17,4	17,4	17,4	17,4	17,4
Ø25	Carga Muelle en Reposo / Load of spring at rest	19,5	18,5	17,3	16	15
	Carga Muelle Comprimido / Load of compressed spring	22	22	22	22	22
Ø32	Carga Muelle en Reposo / Load of spring at rest	27,8	25,3	22,8	20,2	17,7
	Carga Muelle Comprimido / Load of compressed spring	30	30	30	30	30
Ø40	Carga Muelle en Reposo / Load of spring at rest	36,4	34	31,7	29,5	27
	Carga Muelle Comprimido / Load of compressed spring	36	36	36	36	36
Ø50	Carga Muelle en Reposo / Load of spring at rest	32	30,5	29	27,8	26,5
	Carga Muelle Comprimido / Load of compressed spring	35	35	35	35	35
Ø63	Carga Muelle en Reposo / Load of spring at rest	61	58,5	56,3	53,5	51,5
	Carga Muelle Comprimido / Load of compressed spring	64,8	64,8	64,8	64,8	64,8
Ø80	Carga Muelle en Reposo / Load of spring at rest	91,3	88	85	82	78,7
	Carga Muelle Comprimido / Load of compressed spring	94	94	94	94	94
Ø100	Carga Muelle en Reposo / Load of spring at rest	150	145	140	134	129
	Carga Muelle Comprimido / Load of compressed spring	156	156	156	156	156

CONSUMO CILINDRO - CYLINDER AIR CONSUMPTION

Ø Cilindro Ø Cylinder	Ø Vástago Ø Rod	Superficie útil en mm ² Working Surface in mm ²	Presión de trabajo en bar Operating pressure in bar									
			1	2	3	4	5	6	7	8	9	10
Consumo aire en NL para cada 10mm. de carrera Air consumption in NL for each 10mm. of stroke												
Ø12	6	Empuje / Thrust = 113 Tracción / Traction = 85	0,002	0,003	0,005	0,006	0,007	0,008	0,009	0,010	0,011	0,012
Ø16	8	Empuje / Thrust = 200 Tracción / Traction = 150	0,004	0,006	0,008	0,010	0,012	0,014	0,016	0,018	0,020	0,022
Ø20	10	Empuje / Thrust = 314 Tracción / Traction = 235	0,006	0,009	0,013	0,016	0,019	0,022	0,025	0,028	0,031	0,035
Ø25	10	Empuje / Thrust = 490 Tracción / Traction = 412	0,010	0,015	0,020	0,025	0,029	0,034	0,039	0,044	0,049	0,054
Ø32	12	Empuje / Thrust = 804 Tracción / Traction = 691	0,016	0,024	0,032	0,040	0,048	0,056	0,064	0,072	0,080	0,088
Ø40	12	Empuje / Thrust = 1257 Tracción / Traction = 1144	0,025	0,038	0,050	0,063	0,075	0,088	0,101	0,113	0,126	0,138
Ø50	16	Empuje / Thrust = 1963 Tracción / Traction = 1762	0,039	0,059	0,079	0,098	0,118	0,137	0,157	0,177	0,196	0,216
Ø63	16	Empuje / Thrust = 3117 Tracción / Traction = 2916	0,062	0,094	0,125	0,156	0,187	0,218	0,249	0,281	0,312	0,343
Ø80	20	Empuje / Thrust = 5027 Tracción / Traction = 4712	0,101	0,151	0,201	0,251	0,302	0,352	0,402	0,452	0,503	0,553
Ø100	25	Empuje / Thrust = 7854 Tracción / Traction = 7363	0,157	0,236	0,314	0,393	0,471	0,550	0,628	0,707	0,785	0,864

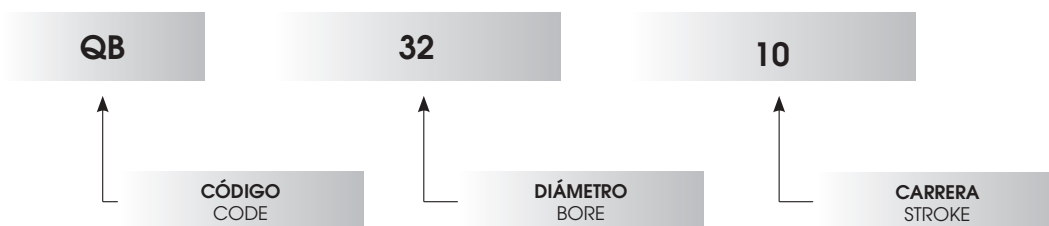
Ejemplo de pedido / How to Order

CARRERAS STANDARD mm. - STD STROKES

Ø mm.	5	10	15	20	25	30	40	50	60	80	100	125	150	200
12	▲#	▲●#	●#	●#	●#	●#	●#							
16	▲●#	▲●#	▲●#	▲●#	▲●#	●#	●#							
20	▲●#	▲●#	▲●#	▲●#	▲●#	●#	●#	●#						
25	▲●#	▲●#	▲●#	▲●#	▲●#	●#	●#	●#						
32	▲●#	▲●#	▲●#	▲●#	▲●#	●#	●#	●#	●#	●#	●	●	●	
40	▲●#	▲●#	▲●#	▲●#	▲●#	●#	●#	●#	●#	●#	●	●	●	
50	▲●#	▲●#	▲●#	▲●#	▲●#	●#	●#	●#	●#	●#	●	●	●	●
63	▲●#	▲●#	▲●#	▲●#	▲●#	●#	●#	●#	●#	●#	●	●	●	●
80	▲●#	▲●#	▲●#	▲●#	▲●#	●#	●#	●#	●#	●#	●	●	●	●
100	▲●#	▲●#	▲●#	▲●#	▲●#	●#	●#	●#	●#	●#	●	●	●	●

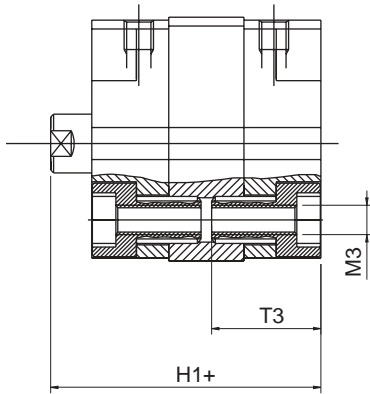
- ▲ QB SIMPLE EFECTO MAGNÉTICO - SINGLE-ACTING MAGNETIC
- ▲ QD SIMPLE EFECTO MAGNÉTICO - MUELLE EN EMPUJE - SINGLE-ACTING MAGNETIC - SPRING THRUST
- QF DOBLE EFECTO MAGNÉTICO - DOUBLE ACTING MAGNETIC
- QJ DOBLE EFECTO VÁSTAGO PASANTE MAGNÉTICO - DOUBLE ACTING MAGNETIC WITH DOUBLE ROD END
- # QFA DOBLE EFECTO MAGNÉTICO ANTIROTACIÓN - DOUBLE-ACTING MAGNETIC ANTIROTATION



D12-16-20-25



D32-40-50-63-80-100

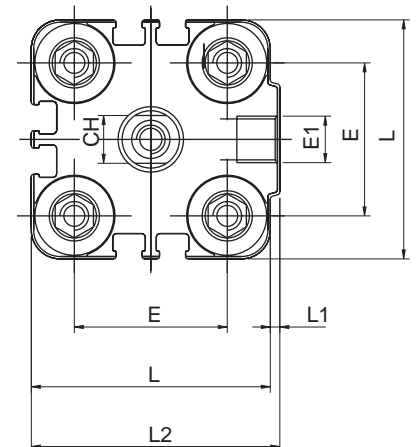
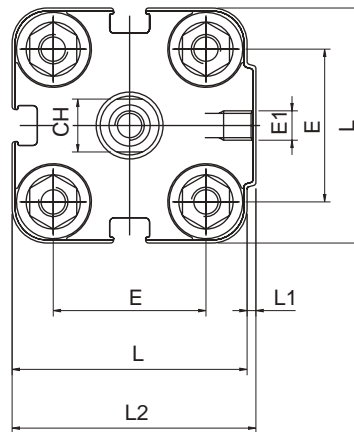
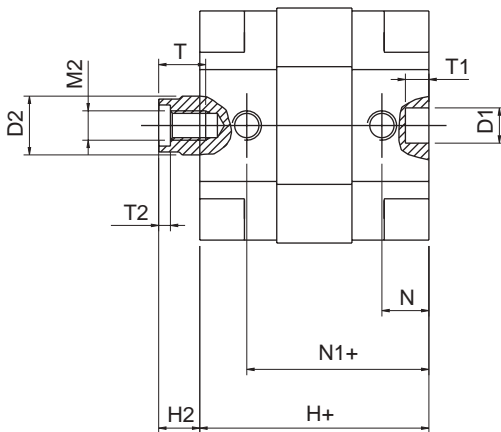

+= añadir la carrera

+ = add stroke

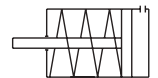

QB

SIMPLE EFECTO MAGNÉTICO - SINGLE-ACTING MAGNETIC

∅ mm.	T	T1	T2	D1	L	E1	M3	T3	M2	H	H2	D2	N	N1	L2	E	L1	H1	CH
12	6	4	1.5	6	29	M5	M4	16	M3	35	7.5	6	6.5	28.5	30	18	1	42.5	5
16	8	4	2	6	29	M5	M4	16	M4	35	8.5	8	6.5	28.5	30	18	1	43.5	7
20	8	4	2	6	36	M5	M5	18.5	M5	39	7	10	8	31	37.5	22	1.5	46	9
25	8	4	2	6	40	M5	M5	18.5	M5	39	7	10	8	31	41.5	26	1.5	46	9
32	10	4	2.8	6	50	G1/8	M6	21.5	M6	42	7	12	6.5	35.5	52	32	2	49	10
40	10	4	2.8	6	60	G1/8	M6	21.5	M6	45.5	8.5	12	7.5	38	62.5	42	2.5	54	10
50	12	4	3.5	6	68	G1/8	M8	23.5	M8	45.5	10	16	7.5	38	71	50	3	55.5	13
63	12	4	3.5	8	87	G1/8	M10	28.5	M8	51	10.5	16	7.5	43.5	91	62	4	61.5	13
80	16	4	4.5	8	107	G1/8	M10	28.5	M10	62	12	20	9.5	52.5	111	82	4	75	17
100	20	4	6	8	128	G1/4	M10	28.5	M12	68	15.5	25	10.5	57.5	133	103	5	83.5	22

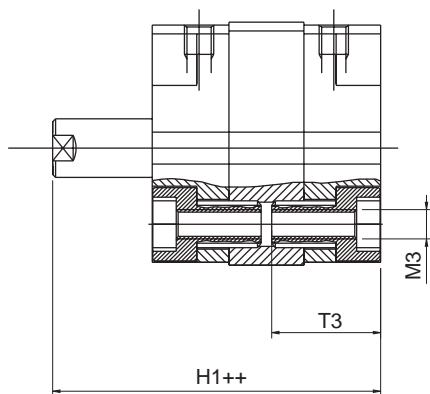

Ø12-16-20-25



Ø32-40-50-63-80-100

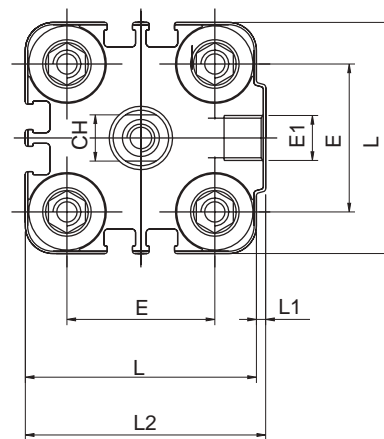
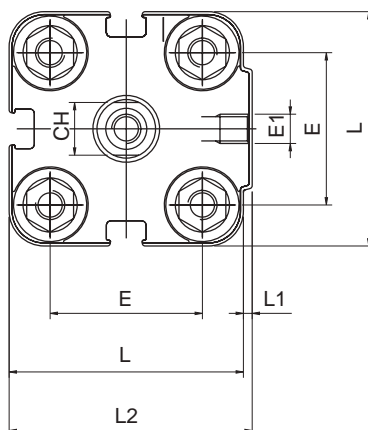
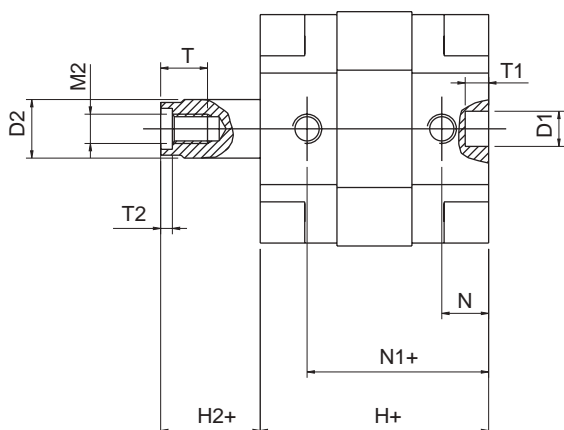

+= añadir la carrera + = add stroke
 += añadir 2 veces la carrera += double stroke dimension and add it



QD

SIMPLE EFECTO MAGNÉTICO - MUELLE EN EMPUJE - SINGLE ACTING MAGNETIC - SPRING THRUST

Ø mm.	T	T1	T2	D1	L	E1	M3	T3	M2	H	H2	D2	N	N1	L2	E	L1	H1	CH
12	6	4	1.5	6	29	M5	M4	16	M3	35	7.5	6	6.5	28.5	30	18	1	42.5	5
16	8	4	2	6	29	M5	M4	16	M4	35	8.5	8	6.5	28.5	30	18	1	43.5	7
20	8	4	2	6	36	M5	M5	18.5	M5	39	7	10	8	31	37.5	22	1.5	46	9
25	8	4	2	6	40	M5	M5	18.5	M5	39	7	10	8	31	41.5	26	1.5	46	9
32	10	4	2.8	6	50	G1/8	M6	21.5	M6	42	7	12	6.5	35.5	52	32	2	49	10
40	10	4	2.8	6	60	G1/8	M6	21.5	M6	45.5	8.5	12	7.5	38	62.5	42	2.5	54	10
50	12	4	3.5	6	68	G1/8	M8	23.5	M8	45.5	10	16	7.5	38	71	50	3	55.5	13
63	12	4	3.5	8	87	G1/8	M10	28.5	M8	51	10.5	16	7.5	43.5	91	62	4	61.5	13
80	16	4	4.5	8	107	G1/8	M10	28.5	M10	62	12	20	9.5	52.5	111	82	4	75	17
100	20	4	6	8	128	G1/4	M10	28.5	M12	68	15.5	25	10.5	57.5	133	103	5	83.5	22

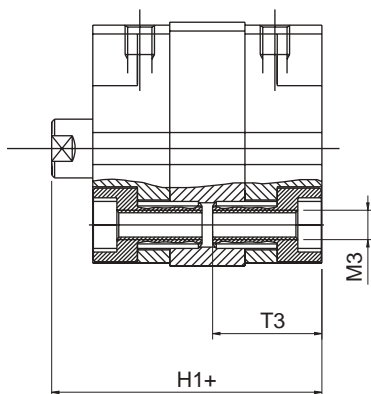

D12-16-20-25



D32-40-50-63-80-100

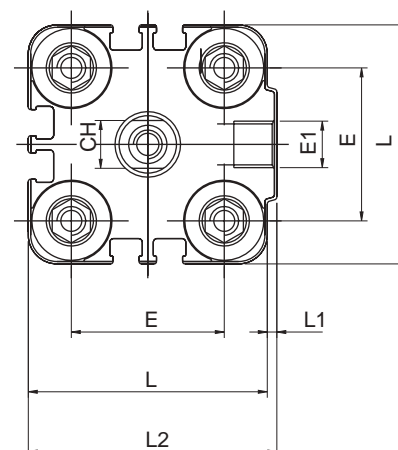
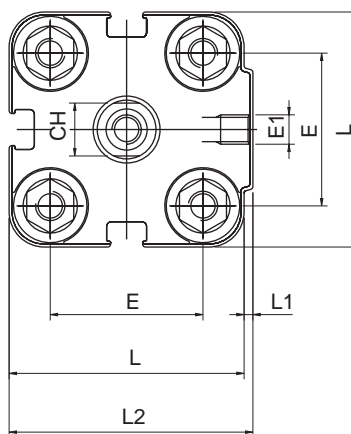
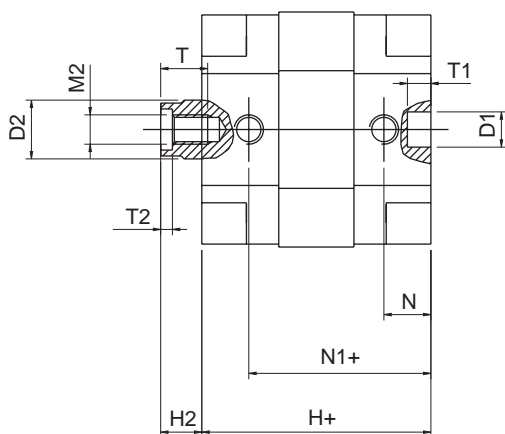

+= añadir la carrera

+ = add stroke

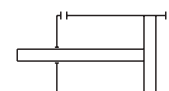

QF

DOBLE EFECTO MAGNÉTICO - DOUBLE-ACTING MAGNETIC

∅ mm.	T	T1	T2	D1	L	E1	M3	T3	M2	H	H2	D2	N	N1	L2	E	L1	H1	CH
12	6	4	1.5	6	29	M5	M4	16	M3	35	7.5	6	6.5	28.5	30	18	1	42.5	5
16	8	4	2	6	29	M5	M4	16	M4	35	8.5	8	6.5	28.5	30	18	1	43.5	7
20	8	4	2	6	36	M5	M5	18.5	M5	39	7	10	8	31	37.5	22	1.5	46	9
25	8	4	2	6	40	M5	M5	18.5	M5	39	7	10	8	31	41.5	26	1.5	46	9
32	10	4	2.8	6	50	G1/8	M6	21.5	M6	42	7	12	6.5	35.5	52	32	2	49	10
40	10	4	2.8	6	60	G1/8	M6	21.5	M6	45.5	8.5	12	7.5	38	62.5	42	2.5	54	10
50	12	4	3.5	6	68	G1/8	M8	23.5	M8	45.5	10	16	7.5	38	71	50	3	55.5	13
63	12	4	3.5	8	87	G1/8	M10	28.5	M8	51	10.5	16	7.5	43.5	91	62	4	61.5	13
80	16	4	4.5	8	107	G1/8	M10	28.5	M10	62	12	20	9.5	52.5	111	82	4	75	17
100	20	4	6	8	128	G1/4	M10	28.5	M12	68	15.5	25	10.5	57.5	133	103	5	83.5	22

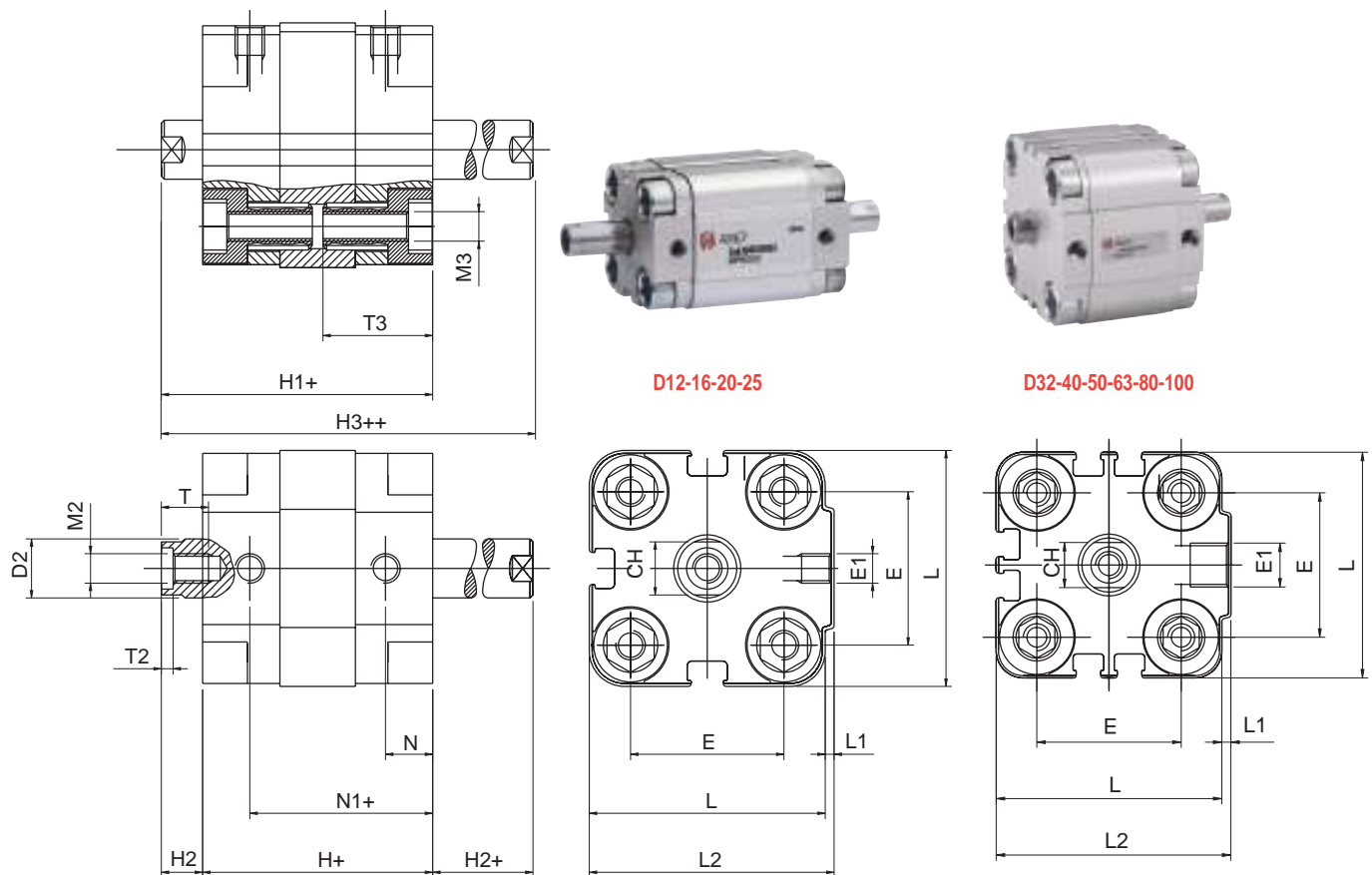

+= añadir la carrera + = add stroke
 += añadir 2 veces la carrera ++ = double stroke dimension and add it

QJ

DOBLE EFECTO VÁSTAGO PASANTE MAGNÉTICO - DOUBLE ACTING MAGNETIC WITH DOUBLE ROD END

Ø mm.	T	M2	T2	D2	L	E1	M3	T3	CH	H	H2	H3	N	N1	L2	E	L1	H1
12	6	M3	1.5	6	29	M5	M4	16	5	35	7.5	50	6.5	28.5	30	18	1	42.5
16	8	M4	2	8	29	M5	M4	16	7	35	8.5	52	6.5	28.5	30	18	1	43.5
20	8	M5	2	10	36	M5	M5	18.5	9	39	7	53	8	31	37.5	22	1.5	46
25	8	M5	2	10	40	M5	M5	18.5	9	39	7	53	8	31	41.5	26	1.5	46
32	10	M6	2.8	12	50	G1/8	M6	21.5	10	42	7	56	6.5	35.5	52	32	2	49
40	10	M6	2.8	12	60	G1/8	M6	21.5	10	45.5	8.5	62.5	7.5	38	62.5	42	2.5	54
50	12	M8	3.5	16	68	G1/8	M8	23.5	13	45.5	10	65.5	7.5	38	71	50	3	55.5
63	12	M8	3.5	16	87	G1/8	M10	28.5	13	51	10.5	72	7.5	43.5	91	62	4	61.5
80	16	M10	4.5	20	107	G1/8	M10	28.5	17	62	12	86	9.5	52.5	111	82	4	75
100	20	M12	6	25	128	G1/4	M10	28.5	22	68	15.5	99	10.5	57.5	133	103	5	83.5

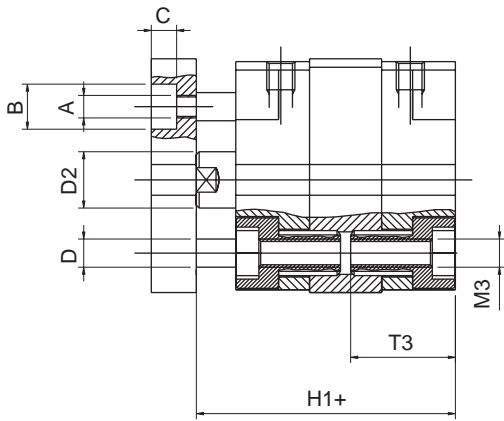

D12-16-20-25



D32-40-50-63-80-100

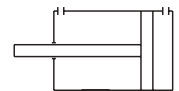
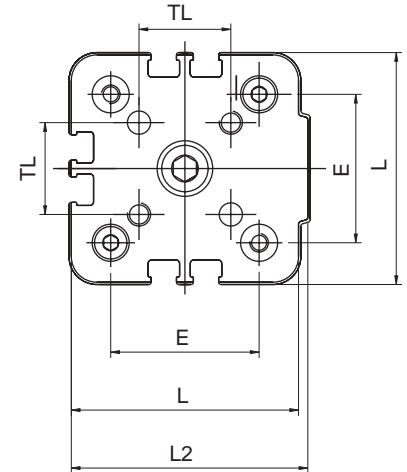
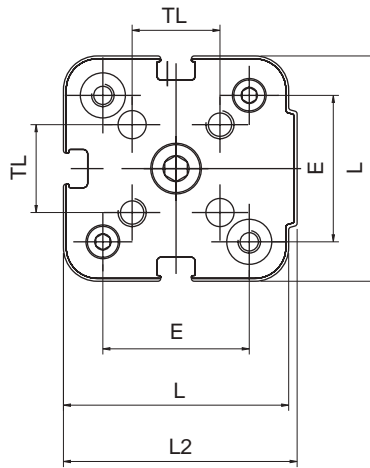
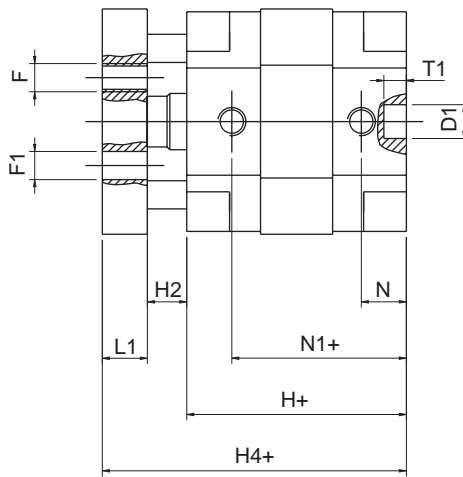

+ = añadir la carrera
* = para carrera corta rosca pasante

+ = add stroke
* = Through threads only on small strokes

QFA

DOBLE EFECTO MAGNÉTICO ANTIROTACIÓN - DOUBLE-ACTING MAGNETIC ANTIROTATION

∅ mm.	A	B	C	D	D1	D2	E	F	F1	H	H1	H2	H4	L	L1	L2	M3	N	N1	T1	T3	TL
12	M3	6	3.5	4	6	6	18	M3	3	35	42.5	7.5	47.5	29	5	30	M4	6.5	28.5	4	16	9.9
16	M3	6	3.5	4	6	8	18	M3	3	35	43.5	8.5	48.5	29	5	30	M4	6.5	28.5	4	16	9.9
20	M3	6	3.5	6	6	10	22	M4	4	39	46	7	54	36	8	37.5	M5	8	31	4	18.5	12
25	M4	8	4.5	6	6	10	26	M5	5	39	46	7	54	40	8	41.5	M5	8	31	4	18.5	15.6
32	M4	8	5.5	6	6	12	32	M5	5	42	49	7	59	50	10	52	M6	6.5	35.5	4	21.5	19.8
40	M4	8	5.5	6	6	12	42	M5	5	45.5	54	8.7	64	60	10	62.5	M6	7.5	38	4	21.5	23.3
50	M6	11	7	8	6	16	50	M6	6	45.5	55.5	10.2	67.5	68	12	71	M8	7.5	38	4	23.5	29.7
63	M6	11	7	8	8	16	62	M6	6	51	61.5	10.5	73.5	87	12	91	M10	7.5	43.5	4	28.5	35.4
80	M8	14	9	12	8	20	82	M8	8	62	75	12	89	107	14	111	M10	9.5	52.5	4	28.5	46
100	M8	14	9	12	8	25	103	M10	10	68	83.5	15.5	97.5	128	14	133	M10	10.5	57.5	4	28.5	56.6

Componentes de fijación / Mounting Accessories

MATERIAL: ACERO
MATERIAL: STEEL

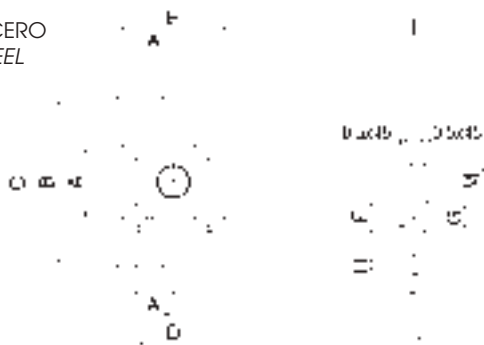

QFL

BRIDA - FLANGE

Ø mm.	A	B	C	D	E	F	G	H	I	L	M
12 - 16	18	43	55	18	29	4.5	9	5.5	10	5.4	10
20	22	55	70	22	36	5.5	10	6.6	10	5.4	12
25	26	60	76	26	40	5.5	10	6.6	10	5.4	12

MATERIAL: ACERO
MATERIAL: STEEL



QFL

BRIDA - FLANGE

Ø mm.	A	B	C	D	E	F	G	H	I	L	M	N
32	32	65	80	32	50	6.6	11	7	10	6.4	14	32
40	42	82	102	42	60	6.6	11	9	10	6.4	14	36
50	50	90	110	50	68	9	15	9	12	8.6	18	45
63	62	110	130	62	87	11	15	9	15	10.6	18	50
80	82	135	160	82	107	11	18	12	15	10.6	23	63
100	103	163	190	103	128	11	18	14	15	10.6	28	75

MATERIAL: ACERO
MATERIAL: STEEL



QCP

PATA - LOW-RISE PEDESTAL

Ø mm.	C	B	D	E	F	G	H	I	S	T	R	U	Z
12 - 16	18	18	30	17.5	17.5	4.4	13	13	3	15	9	2	5.5
20	22	22	36	22	22	5.4	16	16	4	17	10	2	6.6
25	26	26	40	22	23	5.4	17	16	4	19	11	2	6.6
32	32	32	50	26	24	6.6	16	18	5	20	12	2	6.6

MATERIAL: ACERO
MATERIAL: STEEL



QCP

PATA - LOW-RISE PEDESTAL

Ø mm.	C	B	D	E	F	G	H	I	S	U	Z
40	42	42	60	28	29.5	6.6	21.5	20	5	5	9
50	50	50	68	32	30	9	22	24	6	5	9
63	62	62	84	39	39	9	28.5	27	6	5	11
80	82	82	102	36.5	36.5	11	24.5	30	8	5	11
100	103	103	123	38.5	38.5	11	26.5	33	8	5	13.5

MATERIAL: ALUMINIO
MATERIAL: ALUMINIUM



QCM

CHARNELA MACHO CON COJINETES AUTOLUBRICANTES - MALE HINGE SELF-LUBRICATING

Ø mm.	A	B	C	D	E	F	G	H	I	L	M	N	O	P	Q
12 - 16	18	27	10	4.5	2.6	6	16	2	6	4.5	10	8	12	3	6
20	22	34	11	5	2.6	6	20	2	8	5.5	12	10	16	3	8
25	26	38	11	5	2.6	6	20	2	8	5.5	12	10	16	3	8

MATERIAL: ALUMINIO
MATERIAL: ALUMINIUM



QCF

CHARNELA HEMBRA CON COJINETES AUTOLUBRICANTES - FEMALE HINGE SELF-LUBRICATING

Ø mm.	A	B	C	D	E	F	G	H	I	L	M	N	O	P	Q
32	32	48	13.5	5.5	5.5	9	22	2.5	10	6.6	14	12	26	45	10
40	42	58	13.5	5.5	5.5	9	25	2.5	12.5	6.6	14	14	28	52	12
50	50	66	15.5	7.5	6.5	11	27	2.5	12.5	9	18	14	32	60	12
63	62	83	18	7.5	6.5	11	32	4	15	11	18	18	40	70	16
80	82	102	19	9	10	13	36	4	15	11	23	18	50	90	16
100	103	123	19	9	10	15	41	4	20	11	28	23	60	110	20

MATERIAL: ALUMINIO
MATERIAL: ALUMINIUM

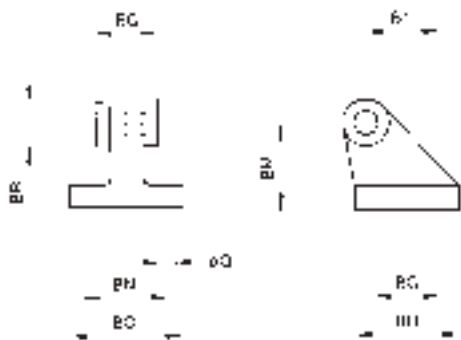

VAS

ARTICULACIÓN A ESCUADRA - SQUARE JOINT

Ø mm.	Q	BG	BH	BI	BM	BN	BO	BQ	BR
32	6.6	18	31	21	32	38	51	26	20
40	6.6	22	35	24	36	41	54	28	22
50	9	30	45	33	45	50	65	32	26
63	9	35	50	37	50	52	67	40	30
80	11	40	60	47	63	66	86	50	30
100	11	50	70	55	71	76	96	60	38

MATERIAL: ACERO
MATERIAL: STEEL

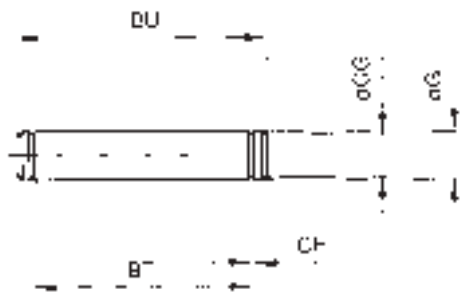

VPE

PERNO PARA CHARNELA CON SEEGER - PIN WITH SEEGER

Ø mm.	G	BT	BU	CG	CH
32	10	46	53	9.6	1.1
40	12	53	60	11.5	1.1
50	12	61	68	11.5	1.1
63	16	71	78	15.2	1.1
80	16	91	98	15.2	1.1
100	20	111	118	19	1.3

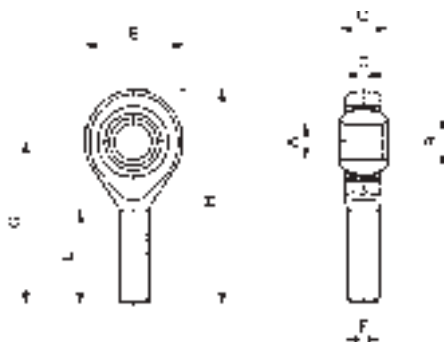

TM

RÓTULA MACHO - MALE ROD ENDS

Ø mm.	A	B	C	Ø	D	E	F	G	H	L	CARGA RADIAL		PESO
											DINÁMICA	ESTÁTICA	
20 - 25	5	7.5	8	11.11	7.5	18	M5x0.8	33	42	19	430	1000	13
32 - 40	6	8.9	9	12.7	7.5	20	M6x1	36	46	21	470	1100	15
50 - 63	8	10.4	12	15.88	9.5	24	M8x1.25	42	54	25	780	1900	34
80	10	12.9	14	19.05	11.5	30	M10x1.5	48	63	28	1200	3100	70
100	12	15.4	16	22.23	12.5	34	M12x1.75	54	71	32	1400	3700	110

Cilindros Carrera Corta / Short Stroke Cylinders

Las dimensiones de los cilindros de carrera corta son por excelencia las más pequeñas, estas características hacen que sean los más aconsejables para espacios reducidos. El nuevo diseño ha sido dotado por tres lados de unas guías en las cuales es posible adaptarse sensores magnéticos y amortiguaciones elásticas al final de la carrera. Las distancias fijadas entre los centros del cilindro de diámetro 20 hasta 25 mm están diseñadas conforme al estándar UNITOP, y de 32 a 100 mm según normas estándar VDMA ISO 6431.

The overall dimensions of the short stroke cylinders are absolutely the smallest, this characteristic identify this line as the most suitable to be used in reduced spaces. Over the last generation outside profile, on three sides, it has been obtained the guides on whom it is possible to assembly the disappearance switches and elastic bumpers at the stroke end. The fixing distance between cylinder's centers for diameter 20 and 25 mm are in conformity with the standard UNITOP, from 32 to 100 mm match the VDMA ISO 6431 standards.



Características Técnicas / Technical Characteristics

Presiones / Pressures

Presión mínima / Minimum pressure: 1 bar (0.1 MPa)
Presión máxima / Maximum pressure: 10 bar (1 MPa)

Temperaturas / Temperatures

Temperatura mínima / Minimum temperature: 0 °C
 (-20 °C con aire seco / with dry air)
Temperatura máxima / Maximum temperature: +80 °C

Fluidos compatibles / Fluids

Aire comprimido filtrado lubricado y no lubricado
 Filtered and lubricated compressed air as well as non lubricated air.

Funcionamiento / Functioning

Simple efecto magnético, Doble efecto magnético
Vástago simple o pasante magnético, Antirotación magnético.
 Single and Double-acting magnetic, Single or through piston rod magnetic Antirotation magnetic.

Diámetros / Bores

De 12 a 100 mm / From 12 to 100 mm

Carreras / Strokes

Carreras Standard / Standard Strokes
De 5 a 100 mm / From 5 to 100 mm

Características Técnicas / Technical Characteristics

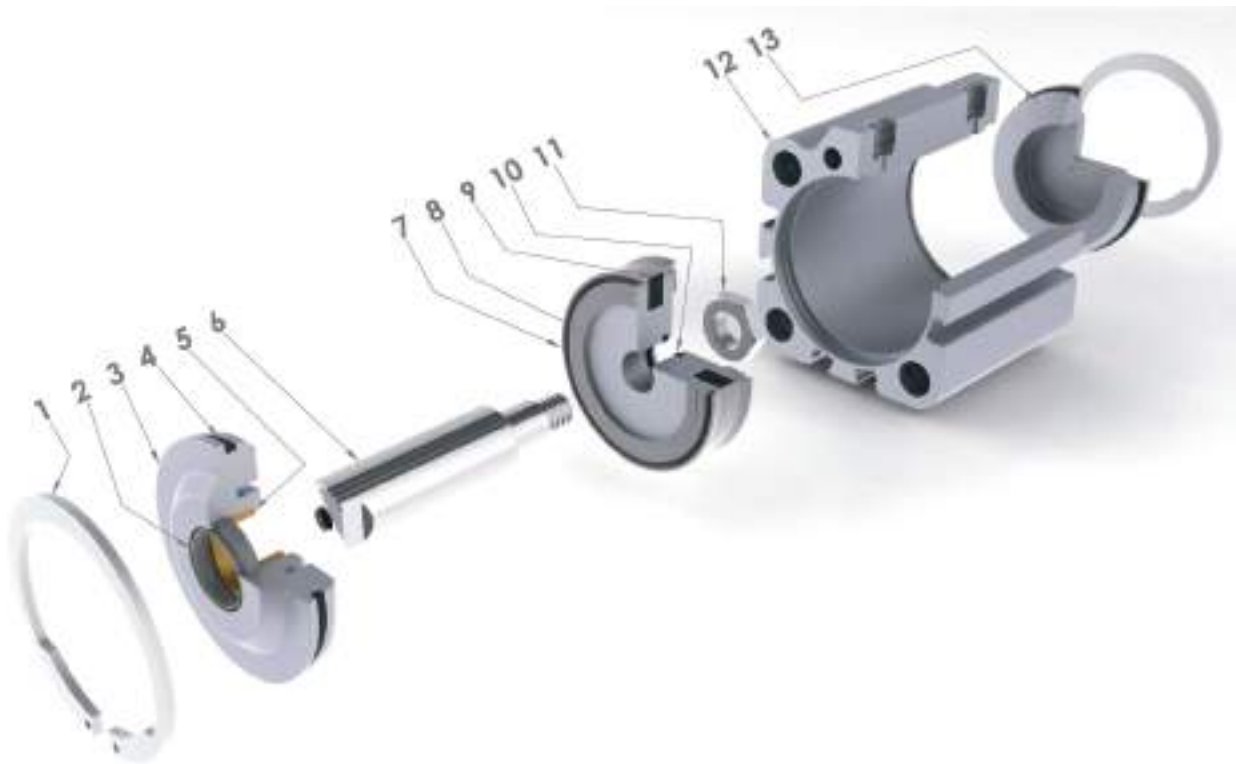

Materiales y Componentes / Component Parts and Materials

- | | |
|---|---|
| 1 Seeger en acero | 1 Steel Seeger |
| 2 Junta vástago en poliuretano | 2 Polyurethane Rod Seal |
| 3 Tapa anterior en aluminio anodizado | 3 Anodised aluminium Front cover |
| 4 Juntas en NBR | 4 NBR Seals |
| 5 Cojinete en bronce sinterizado | 5 Sintered bronze Bearing |
| 6 Vástago pistón acero cromado
(AISI 303 de 12 a 25) (C40 de 32 a 100) | 6 Chrome steel Piston rod
(AISI 303 from 12 to 25)(C40 from 32 to 100) |
| 7 Junta pistón en poliuretano | 7 Polyurethane Piston Seal |
| 8 Pistón en aluminio | 8 Aluminium Piston |
| 9 Magnete en plastroferrita | 9 Plastroferrite Magnet |
| 10 Junta tórica en NBR | 10 O-Ring in NBR |
| 11 Tuerca pistón en acero zincado | 11 Zinc-plated steel Piston Nut |
| 12 Camisa cilindro en aluminio anodizado | 12 Anodised aluminium Cylinder shape body |
| 13 Tapa posterior en aluminio anodizado | 13 Anodised aluminium Back cover |

**NB: LAS TAPAS ANTERIOR Y POSTERIOR Ø12 Ø16 Ø20 Ø25 SON EN LATÓN NATURAL
NB: FRONT AND BACK COVER Ø12 Ø16 Ø20 Ø25 ARE MADE IN BRASS**

Fuerzas y Consumos / Forces And Consumptions

FUERZA DE EMPUJE Y TRACCIÓN - THRUST AND TRACTION FORCES

Ø Cilindro Ø Cylinder	Ø Vástago Ø Rod	Superficie útil en mm ² Working Surface in mm ²	Presión de trabajo en bar Operating pressure in bar									
			1	2	3	4	5	6	7	8	9	10
			Fuerza desarrollada en N Output force in N									
Ø12	6	Empuje / Thrust = 113	10	20	30	40	50	60	70	80	90	100
		Tracción / Traction = 85	7,5	15	22	30	37	45	52	60	68	75
Ø16	8	Empuje / Thrust = 200	18	35	53	70	90	105	125	145	160	18
		Tracción / Traction = 150	13	26	40	53	65	80	95	105	120	130
Ø20	10	Empuje / Thrust = 314	28	55	85	110	140	170	195	220	250	280
		Tracción / Traction = 235	21	42	60	85	105	125	150	170	190	210
Ø25	10	Empuje / Thrust = 490	44	88	132	176	220	264	308	352	396	440
		Tracción / Traction = 412	36	72	108	144	180	216	252	288	324	360
Ø32	12	Empuje / Thrust = 804	72	144	216	288	360	432	504	576	648	720
		Tracción / Traction = 691	62	124	186	248	310	372	434	496	558	620
Ø40	12	Empuje / Thrust = 1257	110	220	330	440	550	660	770	880	990	1100
		Tracción / Traction = 1144	100	200	300	400	500	600	700	800	900	1000
Ø50	16	Empuje / Thrust = 1963	175	350	525	700	875	1050	1225	1400	1575	1750
		Tracción / Traction = 1762	155	310	465	620	775	930	1085	1240	1395	1550
Ø63	16	Empuje / Thrust = 3117	280	560	840	1120	1400	1680	1960	2240	2520	2800
		Tracción / Traction = 2916	260	520	780	1040	1300	1560	1820	2080	2340	2600
Ø80	20	Empuje / Thrust = 5027	450	900	1350	1800	2250	2700	3150	3600	4050	4500
		Tracción / Traction = 4712	420	840	1260	1680	2100	2520	2940	3360	3780	4200
Ø100	25	Empuje / Thrust = 7854	700	1400	2100	2800	3500	4200	4900	5650	6360	7000
		Tracción / Traction = 7363	660	1320	1980	2640	3300	3960	4620	5280	5940	6600

FUERZA DEL MUELLE - SPRING TRACTION FORCES

Ø Cilindro Ø Cylinder	Carga Muelle Load Spring	Carrera / Stroke							
		5	10	15	20	25	30	40	50
		Fuerza desarrollada en N Output force in N							
Ø12	Carga Muelle en Reposo / Load of spring at rest	7,5	6,8	6	5,2	4,5			
	Carga Muelle Comprimido / Load of compressed spring	8	8	8	8	8			
Ø16	Carga Muelle en Reposo / Load of spring at rest	12,3	10,8	9,5	7,8	6,5			
	Carga Muelle Comprimido / Load of compressed spring	13,3	13,3	13,3	13,3	13,3			
Ø20	Carga Muelle en Reposo / Load of spring at rest	15,7	14	12,2	10,4	8,7			
	Carga Muelle Comprimido / Load of compressed spring	17,4	17,4	17,4	17,4	17,4			
Ø25	Carga Muelle en Reposo / Load of spring at rest	19,5	18,5	17,3	16	15			
	Carga Muelle Comprimido / Load of compressed spring	22	22	22	22	22			
Ø32	Carga Muelle en Reposo / Load of spring at rest	27,8	25,3	22,8	20,2	17,7			
	Carga Muelle Comprimido / Load of compressed spring	30	30	30	30	30			
Ø40	Carga Muelle en Reposo / Load of spring at rest	36,4	34	31,7	29,5	27			
	Carga Muelle Comprimido / Load of compressed spring	36	36	36	36	36			
Ø50	Carga Muelle en Reposo / Load of spring at rest	32	30,5	29	27,8	26,5			
	Carga Muelle Comprimido / Load of compressed spring	35	35	35	35	35			
Ø63	Carga Muelle en Reposo / Load of spring at rest	61	58,5	56,3	53,5	51,5			
	Carga Muelle Comprimido / Load of compressed spring	64,8	64,8	64,8	64,8	64,8			
Ø80	Carga Muelle en Reposo / Load of spring at rest	91,3	88	85	82	78,7			
	Carga Muelle Comprimido / Load of compressed spring	94	94	94	94	94			
Ø100	Carga Muelle en Reposo / Load of spring at rest	150	145	140	134	129			
	Carga Muelle Comprimido / Load of compressed spring	156	156	156	156	156			

CONSUMO CILINDRO - CYLINDER AIR CONSUMPTION

Ø Cilindro Ø Cylinder	Ø Vástago Ø Rod	Superficie útil en mm ² Working Surface in mm ²	Presión de trabajo en bar Operating pressure in bar									
			1	2	3	4	5	6	7	8	9	10
Consumo aire en NL para cada 10mm. de carrera Air consumption in NL for each 10mm. of stroke												
Ø12	6	Empuje / Thrust = 113 Tracción / Traction = 85	0,002	0,003	0,005	0,006	0,007	0,008	0,009	0,010	0,011	0,012
Ø16	8	Empuje / Thrust = 200 Tracción / Traction = 150	0,004	0,006	0,008	0,010	0,012	0,014	0,016	0,018	0,020	0,022
Ø20	10	Empuje / Thrust = 314 Tracción / Traction = 235	0,006	0,009	0,013	0,016	0,019	0,022	0,025	0,028	0,031	0,035
Ø25	10	Empuje / Thrust = 490 Tracción / Traction = 412	0,010	0,015	0,020	0,025	0,029	0,034	0,039	0,044	0,049	0,054
Ø32	12	Empuje / Thrust = 804 Tracción / Traction = 691	0,016	0,024	0,032	0,040	0,048	0,056	0,064	0,072	0,080	0,088
Ø40	12	Empuje / Thrust = 1257 Tracción / Traction = 1144	0,025	0,038	0,050	0,063	0,075	0,088	0,101	0,113	0,126	0,138
Ø50	16	Empuje / Thrust = 1963 Tracción / Traction = 1762	0,039	0,059	0,079	0,098	0,118	0,137	0,157	0,177	0,196	0,216
Ø63	16	Empuje / Thrust = 3117 Tracción / Traction = 2916	0,062	0,094	0,125	0,156	0,187	0,218	0,249	0,281	0,312	0,343
Ø80	20	Empuje / Thrust = 5027 Tracción / Traction = 4712	0,101	0,151	0,201	0,251	0,302	0,352	0,402	0,452	0,503	0,553
Ø100	25	Empuje / Thrust = 7854 Tracción / Traction = 7363	0,157	0,236	0,314	0,393	0,471	0,550	0,628	0,707	0,785	0,864

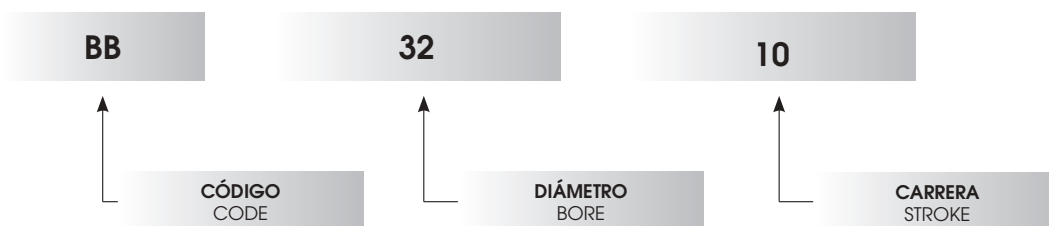
Ejemplo de pedido / How to Order

CARRERAS STANDARD mm. - STD STROKES

Ø mm.	5	10	15	20	25	30	40	50	75	100
12	▲●	▲●	▲●	▲●	▲●	●	●			
16	▲●	▲●	▲●	▲●	▲●	●	●			
20	▲●	▲●	▲●	▲●	▲●	●	●	●		
25	▲●	▲●	▲●	▲●	▲●	●	●	●		
32	▲●	▲●	▲●	▲●	▲●	▲●	▲●	▲●	●	●
40	▲●	▲●	▲●	▲●	▲●	▲●	▲●	▲●	●	●
50	▲●	▲●	▲●	▲●	▲●	▲●	▲●	▲●	●	●
63	▲●	▲●	▲●	▲●	▲●	▲●	▲●	▲●	●	●
80	▲●	▲●	▲●	▲●	▲●	▲●	▲●	▲●	●	●
100	▲●	▲●	▲●	▲●	▲●	▲●	▲●	▲●	●	●

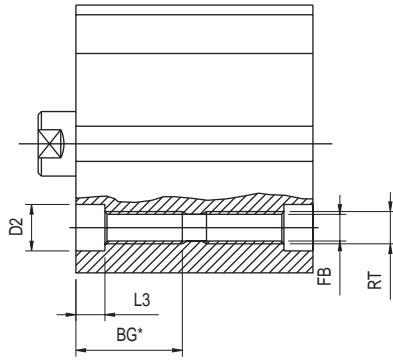
- ▲ BB SIMPLE EFECTO MAGNÉTICO - SINGLE-ACTING MAGNETIC
- ▲ BD SIMPLE EFECTO MAGNÉTICO - MUELLE EN EMPUJE - SINGLE-ACTING MAGNETIC - SPRING THRUST
- BF DOBLE EFECTO MAGNÉTICO - DOUBLE ACTING MAGNETIC
- BJ DOBLE EFECTO VÁSTAGO PASANTE MAGNÉTICO - DOUBLE ACTING MAGNETIC WITH DOUBLE ROD END
- BFA DOBLE EFECTO MAGNÉTICO ANTIROTACIÓN - DOUBLE-ACTING MAGNETIC ANTIROTATION



D12-16-20-25

D32-40-50-63-80-100

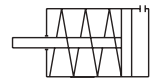
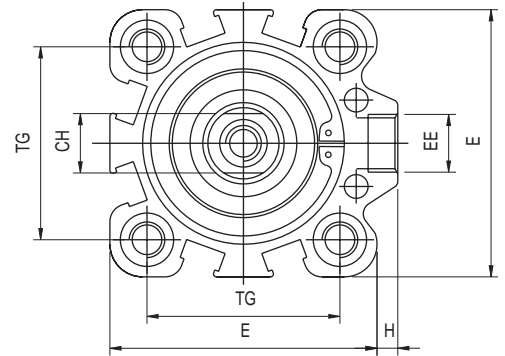
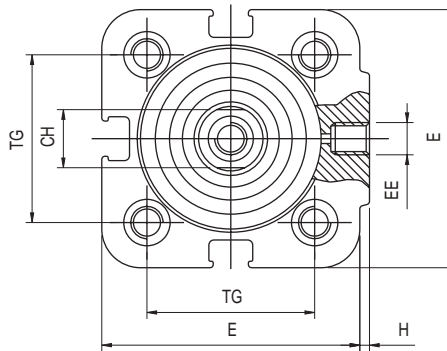
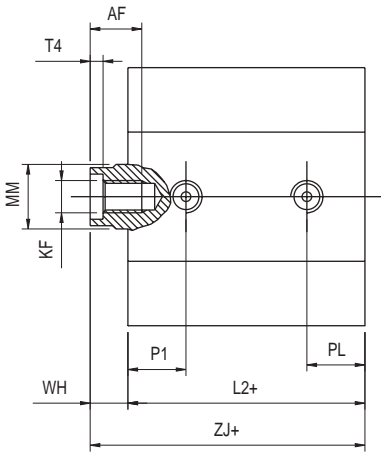

+ = añadir la carrera + = add stroke
 * = para carrera corta rosca pasante * = Through threads only on small strokes

BB

SIMPLE EFECTO MAGNÉTICO - SINGLE-ACTING MAGNETIC

Ø mm.	AF	RT	BG*	D2Ø	E	EE	FBØ	H	KF	L2+	L3	MMØ	P1	PL	T4	TG	WH	ZJ+	CH
12	6	M4	12.5	5.5	29	M5	3.3	1	M3	28	3.5	6	7.5	7.5	1.5	18	6	34	5
16	8	M4	14.5	5.5	29	M5	3.3	1	M4	30.5	3.5	8	8.5	8.5	2	18	6	36.5	7
20	8	M5	16.5	7.2	36	M5	4.2	1.5	M5	31.5	4.5	10	9	9	2	22	6	37.5	9
25	8	M5	16.5	7.2	40	M5	4.2	1.5	M5	31.5	4.5	10	9	9	2	26	6	37.5	9
32	10	M6	21.7	8.5	45	G1/8	5	3.5	M6	32	5.7	12	10	10	2.8	32.5	7	39	10
40	10	M6	21.7	8.5	52	G1/8	5	5	M6	38.5	5.7	12	11	11	2.8	38	7.2	45.7	10
50	12	M8	22.8	10	63.5	G1/8	6.8	7	M8	39	6.8	16	11	11	3.5	46.5	8.5	47.5	13
63	12	M8	22.8	10	77	G1/8	6.8	7	M8	46	6.8	16	11.5	11.5	3.5	56.5	8	54	13
80	16	M10	25	13	92	G1/8	8.5	10	M10	54	9	20	14	14	4.5	72	11	65	17
100	20	M10	25	13	113	G1/4	8.5	13	M12	65	9	25	17.5	17.5	6	89	12	77	22

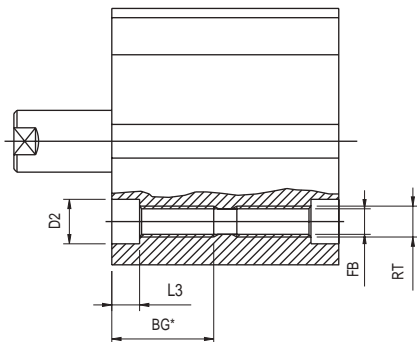

D12-16-20-25

D32-40-50-63-80-100

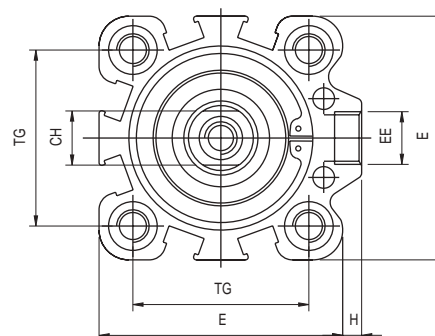
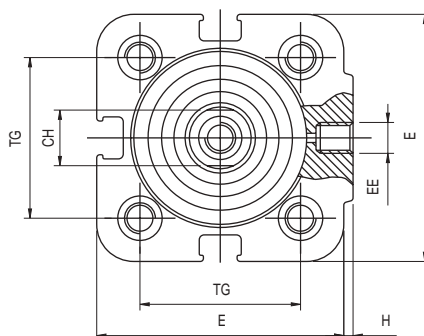
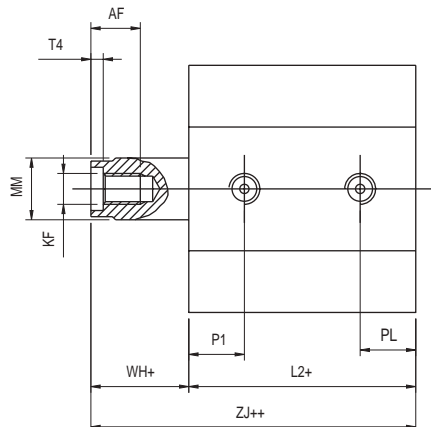

+= añadir la carrera + = add stroke
 += añadir 2 veces la carrera ++ = double stroke dimension and add it
 * = para carrera corta rosca pasante * = Through threads only on small strokes

BD

SIMPLE EFECTO MAGNÉTICO - MUELLE EN EMPUJE - SINGLE ACTING MAGNETIC - SPRING THRUST

Ø mm.	AF	RT	BG*	D2Ø	E	EE	FBØ	H	KF	L2+	L3	MMØ	P1	PL	T4	TG	WH+	ZJ++	CH
12	6	M4	12.5	5.5	29	M5	3.3	1	M3	28	3.5	6	7.5	7.5	1.5	18	6	34	5
16	8	M4	14.5	5.5	29	M5	3.3	1	M4	30.5	3.5	8	8.5	8.5	2	18	6	36.5	7
20	8	M5	16.5	7.2	36	M5	4.2	1.5	M5	31.5	4.5	10	9	9	2	22	6	37.5	9
25	8	M5	16.5	7.2	40	M5	4.2	1.5	M5	31.5	4.5	10	9	9	2	26	6	37.5	9
32	10	M6	21.7	8.5	45	G1/8	5	3.5	M6	32	5.7	12	10	10	2.8	32.5	7	39	10
40	10	M6	21.7	8.5	52	G1/8	5	5	M6	38.5	5.7	12	11	11	2.8	38	7.2	45.7	10
50	12	M8	22.8	10	63.5	G1/8	6.8	7	M8	39	6.8	16	11	11	3.5	46.5	8.5	47.5	13
63	12	M8	22.8	10	77	G1/8	6.8	7	M8	46	6.8	16	11.5	11.5	3.5	56.5	8	54	13
80	16	M10	25	13	92	G1/8	8.5	10	M10	54	9	20	14	14	4.5	72	11	65	17
100	20	M10	25	13	113	G1/4	8.5	13	M12	65	9	25	17.5	17.5	6	89	12	77	22

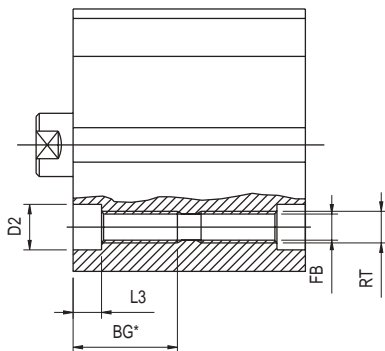

D12-16-20-25

D32-40-50-63-80-100

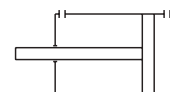
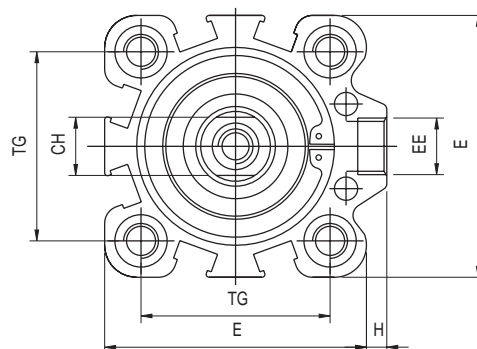
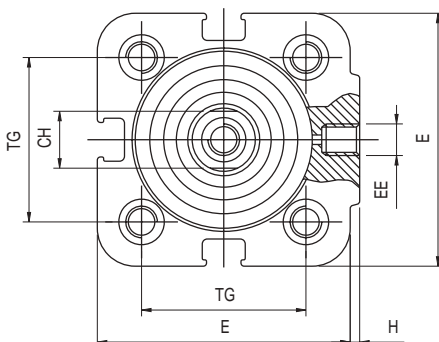
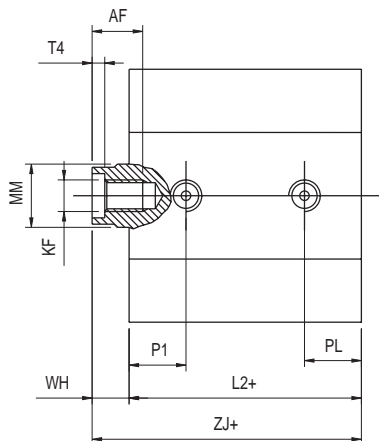

+ = añadir la carrera + = add stroke
 * = para carrera corta rosca pasante * = Through threads only on small strokes

BF

DOBLE EFECTO MAGNÉTICO - DOUBLE-ACTING MAGNETIC

Ø mm.	AF	RT	BG*	D2Ø	E	EE	FBØ	H	KF	L2+	L3	MMØ	P1	PL	T4	TG	WH	ZJ+	CH
12	6	M4	12.5	5.5	29	M5	3.3	1	M3	28	3.5	6	7.5	7.5	1.5	18	6	34	5
16	8	M4	14.5	5.5	29	M5	3.3	1	M4	30.5	3.5	8	8.5	8.5	2	18	6	36.5	7
20	8	M5	16.5	7.2	36	M5	4.2	1.5	M5	31.5	4.5	10	9	9	2	22	6	37.5	9
25	8	M5	16.5	7.2	40	M5	4.2	1.5	M5	31.5	4.5	10	9	9	2	26	6	37.5	9
32	10	M6	21.7	8.5	45	G1/8	5	3.5	M6	32	5.7	12	10	10	2.8	32.5	7	39	10
40	10	M6	21.7	8.5	52	G1/8	5	5	M6	38.5	5.7	12	11	11	2.8	38	7.2	45.7	10
50	12	M8	22.8	10	63.5	G1/8	6.8	7	M8	39	6.8	16	11	11	3.5	46.5	8.5	47.5	13
63	12	M8	22.8	10	77	G1/8	6.8	7	M8	46	6.8	16	11.5	11.5	3.5	56.5	8	54	13
80	16	M10	25	13	92	G1/8	8.5	10	M10	54	9	20	14	14	4.5	72	11	65	17
100	20	M10	25	13	113	G1/4	8.5	13	M12	65	9	25	17.5	17.5	6	89	12	77	22

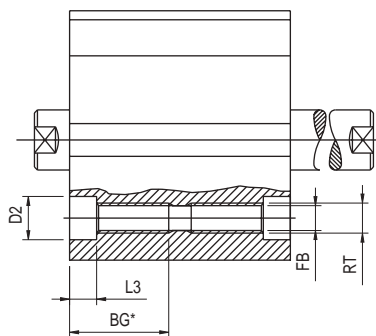

D12-16-20-25



D32-40-50-63-80-100

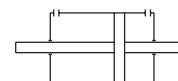
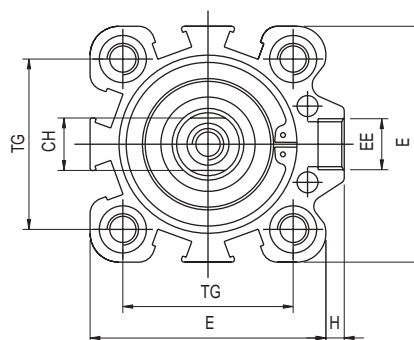
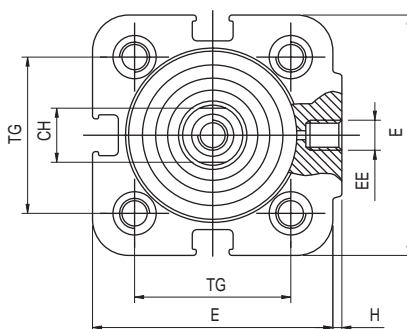
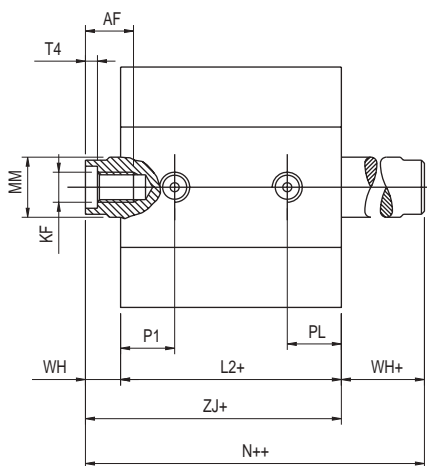

+= añadir la carrera += add stroke
 += añadir 2 veces la carrera += double stroke dimension and add it
 * = para carrera corta rosca pasante * = Through threads only on small strokes

BJ

DOBLE EFECTO VÁSTAGO PASANTE MAGNÉTICO - DOUBLE ACTING MAGNETIC WITH DOUBLE ROD END

Ø mm.	AF	RT	BG*	D2Ø	E	EE	FBØ	H	KF	CH	L2	L3	MMØ	P1	PL	T4	TG	N++	WH/WH+	ZJ+
12	6	M4	12.5	5.5	29	M5	3.3	1	M3	5	28	3.5	6	7.5	7.5	1.5	18	40	6	34
16	8	M4	14.5	5.5	29	M5	3.3	1	M4	7	30.5	3.5	8	8.5	8.5	2	18	42.5	6	36.5
20	8	M5	16.5	7.2	36	M5	4.2	1.5	M5	9	31.5	4.5	10	9	9	2	22	43.5	6	37.5
25	8	M5	16.5	7.2	40	M5	4.2	1.5	M5	9	31.5	4.5	10	9	9	2	26	43.5	6	37.5
32	10	M6	21.7	8.5	45	G1/8	5	3.5	M6	10	32	5.7	12	10	10	2.8	32.5	46	7	39
40	10	M6	21.7	8.5	52	G1/8	5	5	M6	10	38.5	5.7	12	11	11	2.8	38	53	7.2	45.7
50	12	M8	22.8	10	63.5	G1/8	6.8	7	M8	13	39	6.8	16	11	11	3.5	46.5	56	8.5	47.5
63	12	M8	22.8	10	77	G1/8	6.8	7	M8	13	46	6.8	16	11.5	11.5	3.5	56.5	62	8	54
80	16	M10	25	13	92	G1/8	8.5	10	M10	17	54	9	20	14	14	4.5	72	76	11	65
100	20	M10	25	13	113	G1/4	8.5	13	M12	22	65	9	25	17.5	17.5	6	89	89	12	77

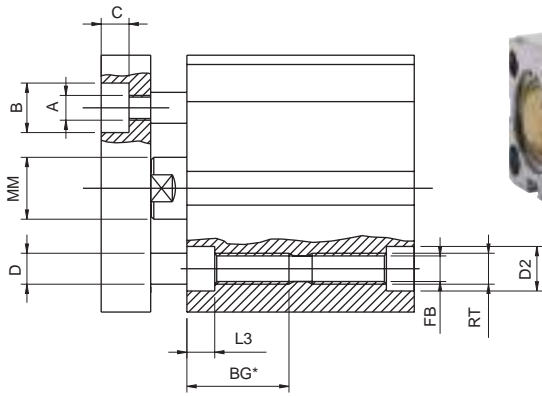

D12-16-20-25

D32-40-50-63-80-100

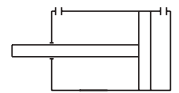
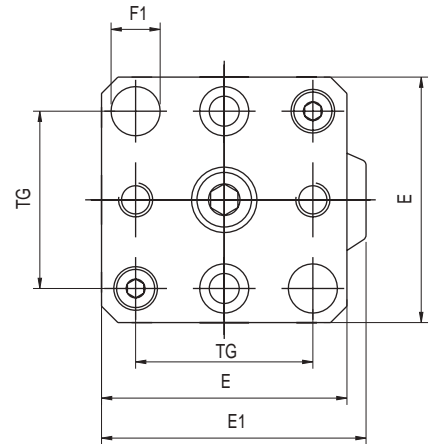
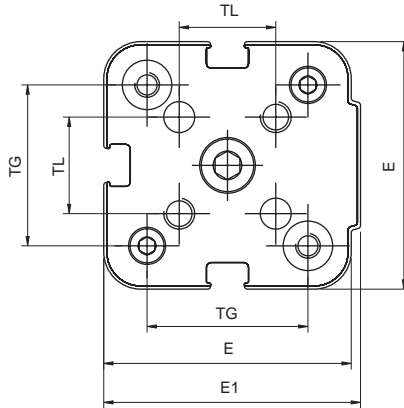
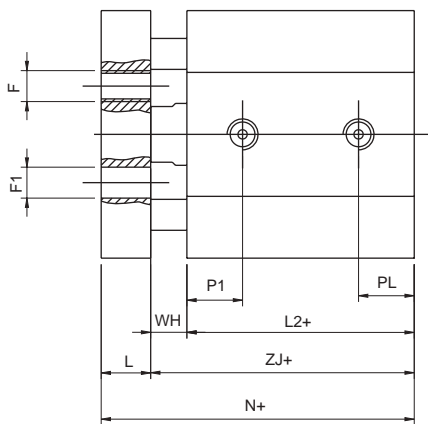

+ = añadir la carrera + = add stroke
 * = para carrera corta rosca pasante * = Through threads only on small strokes

BFA

DOBLE EFECTO MAGNÉTICO ANTIROTACIÓN - DOUBLE-ACTING MAGNETIC ANTIROTATION

Ø mm.	A	BØ	C	DØ	E	E1	F	F1Ø	FBØ	RT	BG*	D2Ø	L	L2+	L3	MMØ	P1	PL	TG	TL	WH	ZJ+	N+
12	M3	6	3.5	4	29	30	M3	3	3.5	M4	12.5	5.5	5	28	3.5	6	7.5	7.5	18	9.9	6	34	39
16	M3	6	3.5	4	29	30	M3	3	3.5	M4	14.5	5.5	5	30.5	3.5	8	8.5	8.5	18	9.9	6	36.5	41.5
20	M3	6	3.5	6	36	37.5	M4	4	4.2	M5	16.5	7	8	31.5	4.5	10	9	9	22	12	6	37.5	45.5
25	M4	8	4.5	6	40	41.5	M5	5	4.2	M5	16.5	7	8	31.5	4.5	10	9	9	26	15.6	6	37.5	45.5
32	4.5	8	4.5	6	45	48.5	M5	9	5	M6	21.7	8.5	10	32	5.7	12	10	10	32.5	-	7	39	48
40	4.5	8	4.5	6	52	57	M5	9	5	M6	21.7	8.5	10	38.5	5.7	12	11	11	38	-	7.2	45.7	55.5
50	5.5	9	5.5	8	63.5	70.5	M6	10	6.8	M8	22.8	10	12	39	6.8	16	11	11	46.5	-	8.5	47.5	59
63	5.5	9	5.5	8	77	84	M6	14	6.8	M8	22.8	10	12	46	6.8	16	11.5	11.5	56.5	-	8	54	66
80	8.5	14	9	12	92	102	M8	14	8.5	M10	25	13	14	54	9	20	14	14	72	-	11	65	79
100	8.5	14	9	12	113	126	M8	17	8.5	M10	25	13	14	65	9	25	17.5	17.5	89	-	12	77	91

Componentes de fijación / Mounting Accessories

MATERIAL: ACERO
MATERIAL: STEEL

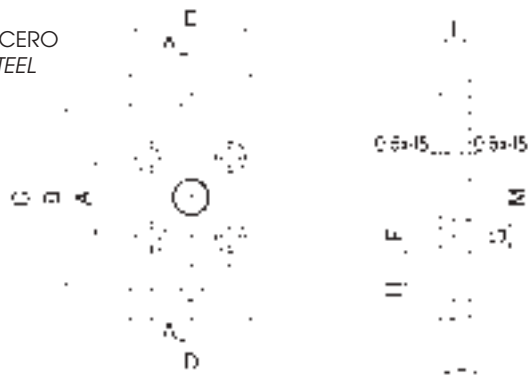

QFL

BRIDA - FLANGE

Ø mm.	A	B	C	D	E	F	G	H	I	L	M
12 - 16	18	43	55	18	29	4.5	9	5.5	10	5.4	10
20	22	55	70	22	36	5.5	10	6.6	10	5.4	12
25	26	60	76	26	40	5.5	10	6.6	10	5.4	12

MATERIAL: ACERO
MATERIAL: STEEL

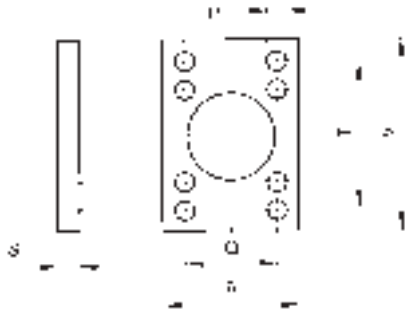

VFL

BRIDA - FLANGE

Ø mm.	P	Q	S	R	T	V
32	7	32	10	45	64	80
40	9	36	10	52	72	90
50	9	45	12	65	90	110
63	9	50	12	75	100	120
80	12	63	16	95	126	150
100	14	75	16	115	150	170

MATERIAL: ACERO
MATERIAL: STEEL



QCP

PATA - LOW-RISE PEDESTAL

Ø mm.	C	B	D	E	F	G	H	I	S	T	R	U	Z
12 - 16	18	18	30	17.5	17.5	4.4	13	13	3	15	9	2	5.5
20	22	22	36	22	22	5.4	16	16	4	17	10	2	6.6
25	26	26	40	22	23	5.4	17	16	4	19	11	2	6.6

MATERIAL: ACERO
MATERIAL: STEEL

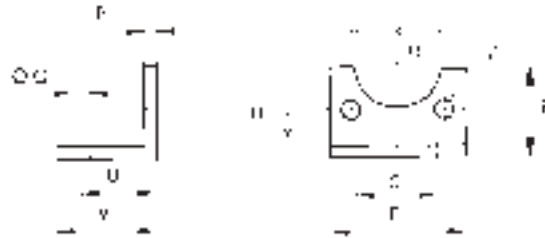

VCP

PATA - LOW - RISE PEDESTAL

Ø mm.	B	C	E	F	O	U	V	R	Z	X	Y	H
32	4	32	45	30	7	24	35	15	7	32.5	15.75	32
40	4	36	52	30	10	28	36	17.5	7	38	17	36
50	5	45	65	36	10	32	47	20	9	46.5	21.75	45
63	5	50	75	35	10	32	45	22.5	9	56.5	21.75	50
80	6	63	95	47	12	41	55	22.5	11	72	27	63
100	6	75	115	53	14.5	41	57	27.5	11	89	26.5	71

MATERIAL: ALUMINIO
MATERIAL: ALUMINIUM



QCM

CHARNELA MACHO CON COJINETES AUTOLUBRICANTES - MALE HINGE SELF-LUBRICATING

Ø mm.	A	B	C	D	E	F	G	H	I	L	M	N	O	P	Q
12 - 16	18	27	10	4.5	2.6	6	16	2	6	4.5	10	8	12	3	6
20	22	34	11	5	2.6	6	20	2	8	5.5	12	10	16	3	8
25	26	38	11	5	2.6	6	20	2	8	5.5	12	10	16	3	8

MATERIAL: ALUMINIO
MATERIAL: ALUMINIUM

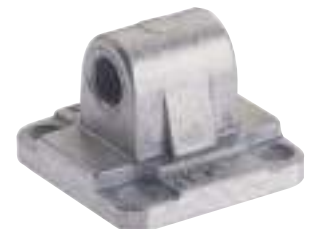
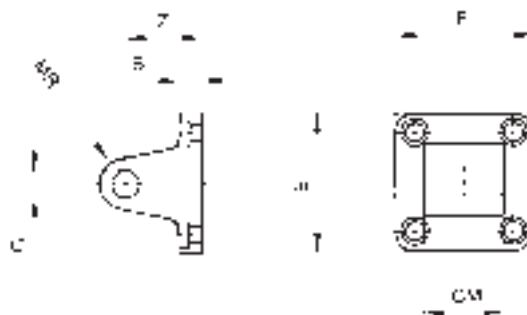

VCM

CHARNELA MACHO - MALE CLEVIS BRACKET

Ø mm.	B	E	G	Z	CM	MR
32	9	45	10	22	26	10
40	9	52	12	25	28	12
50	11	65	12	27	32	12
63	11	75	16	32	40	16
80	14	95	16	36	50	16
100	14	115	20	41	60	20

MATERIAL: ALUMINIO
MATERIAL: ALUMINIUM

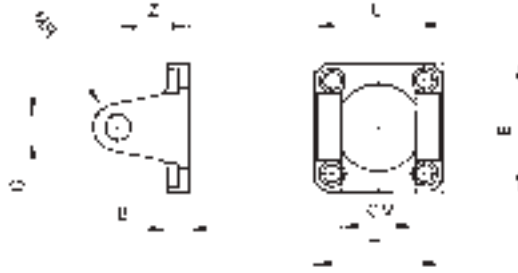

VCF

CHARNELA HEMBRA CON COJINETES AUTOLUBRICANTES - FEMALE CLEVIS BRACKET SELF-LUBRICATING

Ø mm.	B	E	G	T	Z	CM	MR
32	9	45	10	45	22	26	10
40	9	52	12	52	25	28	12
50	11	65	12	60	27	32	12
63	11	75	16	70	32	40	16
80	14	95	16	90	36	50	16
100	14	115	20	110	41	60	20

MATERIAL: ALUMINIO
MATERIAL: ALUMINIUM



VAS

ARTICULACIÓN A ESCUADRA CON COJINETES AUTOLUBRICANTES - SQUARE JOINT SELF-LUBRICATING

Ø mm.	Q	BG	BH	B1	BM	BN	BO	BQ	BR
32	6.6	18	31	21	32	38	51	26	20
40	6.6	22	35	24	36	41	54	28	22
50	9	30	45	33	45	50	65	32	26
63	9	35	50	37	50	52	67	40	30
80	11	40	60	47	63	66	86	50	30
100	11	50	70	55	71	76	96	60	38

MATERIAL: ACERO
MATERIAL: STEEL

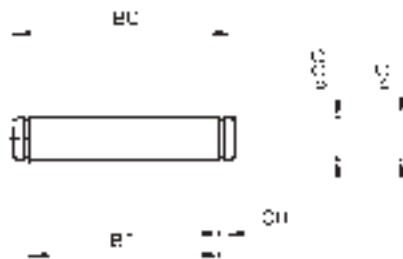

VPE

PERNO PARA CHARNELA CON SEEGER - PIN WITH SEEGER

Ø mm.	G	BT	BU	CG	CH
32	10	46	53	9.6	1.1
40	12	53	60	11.5	1.1
50	12	61	68	11.5	1.1
63	16	71	78	15.2	1.1
80	16	91	98	15.2	1.1
100	20	111	118	19	1.3

MATERIAL: ACERO
MATERIAL: STEEL

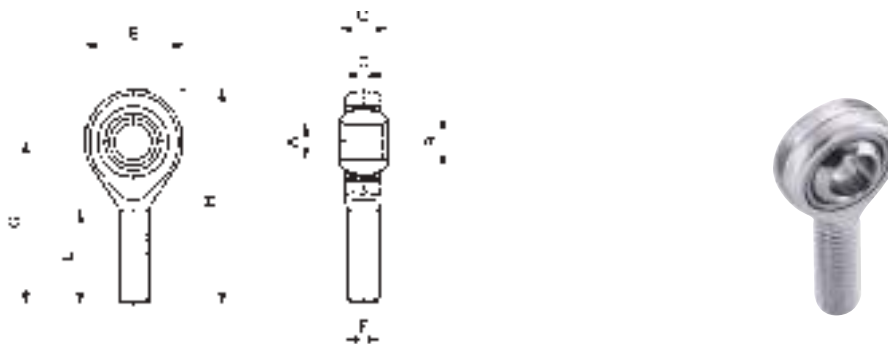

TM

RÓTULA MACHO - MALE ROD ENDS

Ø mm.	A	B	C	Ø	D	E	F	G	H	L	CARGA RADIAL		PESO
											DINÁMICA	ESTÁTICA	
20 - 25	5	7.5	8	11.11	7.5	18	M5x0.8	33	42	19	430	1000	13
32 - 40	6	8.9	9	12.7	7.5	20	M6x1	36	46	21	470	1100	15
50 - 63	8	10.4	12	15.88	9.5	24	M8x1.25	42	54	25	780	1900	34
80	10	12.9	14	19.05	11.5	30	M10x1.5	48	63	28	1200	3100	70
100	12	15.4	16	22.23	12.5	34	M12x1.75	54	71	32	1400	3700	110

Cilindros Serie X ISO 15552 / Cylinder X Serie ISO 15552

Los nuevos cilindros de esta serie han sido fabricados según la normativa ISO 15552. La principal característica de estos cilindros es su solidez gracias a su particular diseño estructural, que satisface al máximo las necesidades de deslizamiento y cargas admisibles. Están dotados de amortiguación regulable que se efectúa en las tapas del cilindro.

These cylinders have been manufactured in conformity with Standards ISO 15552. The main characteristic of these cylinders is the solidity, thanks to the particular manufacturing structure they satisfy the maximum needs in terms of sliding performances and admitted loads. They are supplied with adjustable cushioning, which is produced inside of the cover ends.



Características Técnicas / Technical Characteristics

Presiones / Pressures

Presión mínima / Minimum pressure: 1 bar (0.1 MPa)
Presión máxima / Maximum pressure: 10 bar (1 MPa)

Temperaturas / Temperatures

Temperatura mínima / Minimum temperature: 0 °C
 (-20 °C con aire seco / with dry air)
Temperatura máxima / Maximum temperature: +80 °C

Fluidos compatibles / Fluids

Aire comprimido filtrado lubricado y no lubricado
Filtered and lubricated compressed air as well as non lubricated air.

Funcionamiento / Functioning

Doble efecto amortiguado magnético, Simple efecto magnético, Vástago simple o pasante amortiguado magnético, Tándem.

Double-acting cushioned magnetic, Single-acting magnetic Single or through piston rod magnetic, Tandem.

Diámetros / Bores

De 32 a 125 mm.
From 32 to 125 mm.

Carreras / Strokes

Carreras Standard / Standard Strokes
De 25 a 1000 mm / From 25 to 1000 mm

Carreras bajo Demanda / Stroke on Demand
Hasta 2700 mm / Up to 2700 mm

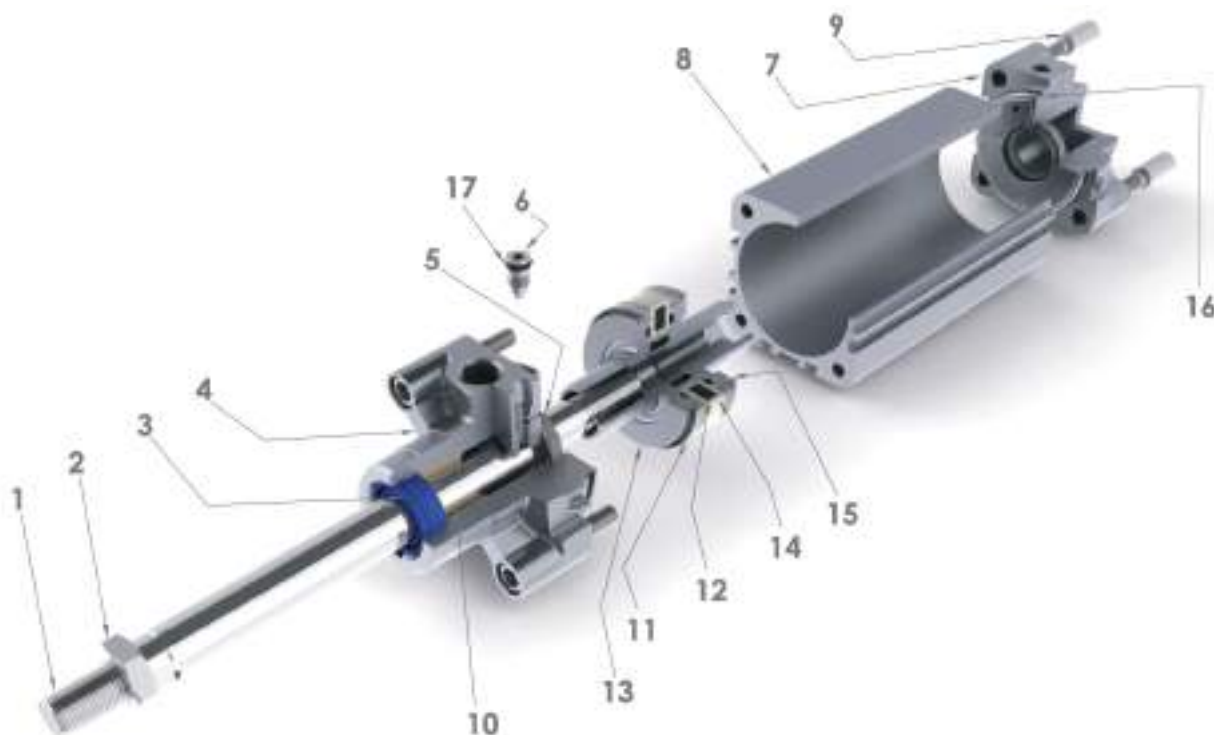
Características Técnicas / Technical Characteristics

Bajo Demanda Juntas en Fkm
Bajo Demanda Rascador metálico
para la limpieza del vástago
If Required Fkm Seals
If Required Metal Scraper
for cleaning of the piston rod

Materiales y Componentes / Component Parts and Materials

1 Vástago pistón acero C40 Cromato	1 Chrome steel C40 piston rod
2 Tuerca en acero zincado	2 Zinc-plated steel Nut
3 Junta vástago en poliuretano o FKM	3 Polyurethane Rod Seal or FKM
4 Tapa anterior en aluminio	4 Aluminium Front cover
5 Juntas amortiguación en poliuretano o FKM	5 Polyurethane Cushioning seals or FKM
6 Tornillos amortiguación en acero zincado	6 Zinc-plated steel Screw cushioning
7 Tapa posterior en aluminio	7 Aluminium Back cover
8 Camisa cilindro en aluminio anodizado	8 Anodised aluminium cylinder shape body
9 Tornillos de fijación en acero zincado	9 Zinc-plated steel Screw
10 Cojinete en bronce sinterizado	10 Sintered bronze Bearing
11 Juntas pistón en poliuretano o FKM	11 Polyurethane Piston seals or FKM
12 Magnete en plastoferrita	12 Plastroferrite Magnet
13 Pistón anterior en aluminio	13 Front Aluminium Piston
14 Anillo portamagnete	14 Support Magnet
15 Pistón posterior en aluminio	15 Rear Aluminium Piston
16 Junta tórica en NBR o FKM	16 O-Ring in NBR or FKM
17 Junta tórica en NBR o FKM	17 O-Ring in NBR or FKM

Fuerzas y Consumos / Forces And Consumptions

FUERZA DE EMPUJE Y TRACCIÓN - THRUST AND TRACTION FORCES

Ø Cilindro Ø Cylinder	Ø Vástago Ø Rod	Superficie útil en mm2 Working Surface in mm2	Presión de trabajo en bar Operating pressure in bar									
			1	2	3	4	5	6	7	8	9	10
			Fuerza desarrollada en N Output force in N									
Ø32	12	Empuje / Thrust = 804 Tracción / Traction = 691	72	144	216	288	360	432	504	576	648	720
Ø40	16	Empuje / Thrust = 1257 Tracción / Traction = 1056	110	220	330	440	550	660	770	880	990	1100
Ø50	20	Empuje / Thrust = 1963 Tracción / Traction = 1649	175	350	525	700	875	1050	1225	1400	1575	1750
Ø63	20	Empuje / Thrust = 3117 Tracción / Traction = 2803	280	560	840	1120	1400	1680	1960	2240	2520	2800
Ø80	25	Empuje / Thrust = 5027 Tracción / Traction = 4536	450	900	1350	1800	2250	2700	3150	3600	4050	4500
Ø100	25	Empuje / Thrust = 7854 Tracción / Traction = 7363	700	1400	2100	2800	3500	4200	4900	5650	6360	7000
Ø125	32	Empuje / Thrust = 12270 Tracción / Traction = 11468	1104	2208	3312	4416	5520	6624	7728	8832	9936	11040

FUERZA DEL MUELLE - SPRING TRACTION FORCES

Ø Cilindro Ø Cylinder	Carga Muelle Load Spring	Carrera / Stroke				
		25	50	75	80	100
		Fuerza desarrollada en N Output force in N				
Ø32	Carga Muelle en Reposo / Load of spring at rest Carga Muelle Comprimido / Load of compressed spring	50	41	33	31,5	24,5
Ø40	Carga Muelle en Reposo / Load of spring at rest Carga Muelle Comprimido / Load of compressed spring	52	43	34	32	25
Ø50	Carga Muelle en Reposo / Load of spring at rest Carga Muelle Comprimido / Load of compressed spring	92	77	64	60	49
Ø63	Carga Muelle en Reposo / Load of spring at rest Carga Muelle Comprimido / Load of compressed spring	92	77	64	60	49
Ø80	Carga Muelle en Reposo / Load of spring at rest Carga Muelle Comprimido / Load of compressed spring	117	98	79	75	59
Ø100	Carga Muelle en Reposo / Load of spring at rest Carga Muelle Comprimido / Load of compressed spring	117	98	79	75	59

CONSUMO CILINDRO - CYLINDER AIR CONSUMPTION

Ø Cilindro Ø Cylinder	Ø Vástago Ø Rod	Superficie útil en mm2 Working Surface in mm2	Presión de trabajo en bar Operating pressure in bar									
			1	2	3	4	5	6	7	8	9	10
			Consumo de aire en NL para cada 10mm. de carrera Air consumption in NL for each 10mm. of stroke									
Ø32	12	Empuje / Thrust = 804 Tracción / Traction = 691	0,016	0,024	0,032	0,040	0,048	0,056	0,064	0,072	0,080	0,088
Ø40	16	Empuje / Thrust = 1257 Tracción / Traction = 1056	0,025	0,038	0,050	0,063	0,075	0,088	0,101	0,113	0,126	0,138
Ø50	20	Empuje / Thrust = 1963 Tracción / Traction = 1649	0,039	0,059	0,079	0,098	0,118	0,137	0,157	0,177	0,196	0,216
Ø63	20	Empuje / Thrust = 3117 Tracción / Traction = 2803	0,062	0,094	0,125	0,156	0,187	0,218	0,249	0,281	0,312	0,343
Ø80	25	Empuje / Thrust = 5027 Tracción / Traction = 4536	0,101	0,151	0,201	0,251	0,302	0,352	0,402	0,452	0,503	0,553
Ø100	25	Empuje / Thrust = 7854 Tracción / Traction = 7363	0,157	0,236	0,314	0,393	0,471	0,550	0,628	0,707	0,785	0,864
Ø125	32	Empuje / Thrust = 12270 Tracción / Traction = 11468	0,245	0,368	0,491	0,614	0,736	0,859	0,982	1,104	1,227	1,350

Tabla de códigos de pedido - Ordering codes

X	H	0 3 2	0 0 2 5	I S
<p>Variantes / Choices</p> <p>VS= Sólo junta vástago en FKM <i>VS= Only rod seal in FKM</i></p> <p>IS= Vástago inox <i>IS= Stainless steel rod</i></p> <p>V= Todas las juntas en FKM <i>V= All FKM seals</i></p> <p>R= Rascador metálico <i>R= Metal scraper</i></p>				
		<p>Carrera mm.</p> <p>Cilindros a simple efecto - Carreras standard mm. = 25-50-75-80-100</p> <p>Cilindros a doble efecto amortiguado - Carreras standard mm.: 25-50-75-80-100-125-150-160-200-250-300-320-350-400-450-500-600-700-800-900-1000</p> <p>Bajo demanda carreras intermedias o superiores- Carrera máxima 2700 mm.</p>		<p>Stroke mm.</p> <p><i>Single acting cylinders - Standard strokes mm. = 25-50-75-80-100</i></p> <p><i>Double acting cylinders cushioned - Standard strokes mm.:</i> <i>25-50-75-80-100-125-150-160-200-250-300-320-350-400-450-500-600-700-800-900-1000</i></p> <p><i>Intermediate or higher strokes are available upon request. - Maximum stroke 2700 mm.</i></p>
		<p>Diámetro mm. / Diameter mm.</p> <p>32-40-50-63-80-100-125</p>		
<p>Ejecución / Execution</p> <p>B= Simple efecto muelle anterior magnético / Single acting front spring magnetic (D.32-100)</p> <p>H= Doble efecto amortiguado magnético / Double acting single rod cushioned magnetic</p> <p>L= Doble efecto amortiguado vástago pasante magnético / Double acting double rod cushioned magnetic</p>				
SERIE X				

CARRERAS STANDARD mm. - STD STROKES

Ø mm.	25	50	75	80	100	125	150	160	200	250	300	320	350	400	450	500	600	700	800	900	1000
32	▲●	▲●	▲●	▲●	▲●	●	●	●	●	●	●	●	●	●	●	●	●	●	●	●	●
40	▲●	▲●	▲●	▲●	▲●	●	●	●	●	●	●	●	●	●	●	●	●	●	●	●	●
50	▲●	▲●	▲●	▲●	▲●	●	●	●	●	●	●	●	●	●	●	●	●	●	●	●	●
63	▲●	▲●	▲●	▲●	▲●	●	●	●	●	●	●	●	●	●	●	●	●	●	●	●	●
80	▲●	▲●	▲●	▲●	▲●	●	●	●	●	●	●	●	●	●	●	●	●	●	●	●	●
100	▲●	▲●	▲●	▲●	▲●	●	●	●	●	●	●	●	●	●	●	●	●	●	●	●	●
125	●	●	●	●	●	●	●	●	●	●	●	●	●	●	●	●	●	●	●	●	●

- ▲ **XB** **SIMPLE EFECTO MAGNÉTICO** - SINGLE-ACTING MAGNETIC
- **XH** **DOBLE EFECTO AMORTIGUADO MAGNÉTICO** - DOUBLE ACTING CUSHIONED MAGNETIC
- **XJ** **DOBLE EFECTO VÁSTAGO PASANTE AMORTIGUADO MAGNÉTICO** - DOUBLE ACTING CUSHIONED MAGNETIC WITH DOUBLE ROD END

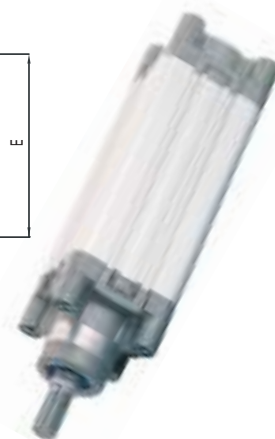
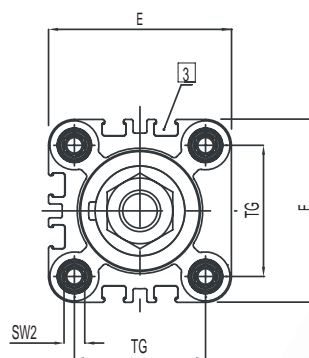
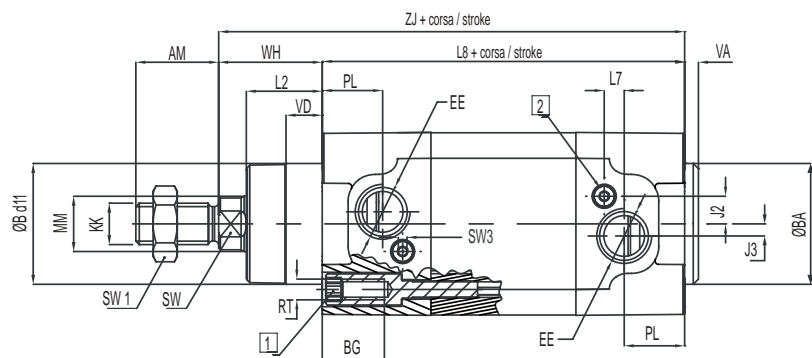

- | | | | |
|---|---|---|---|
| 1 | Tornillos con hexagono interior con rosca hembra para el montaje de los elementos de fijación y para el montaje directo | 1 | Socket head screw with female thread for mounting attachments |
| 2 | Tornillos para la regulación de la amortiguación | 2 | Regulating screw for adjustable end-position cushioning |
| 3 | Ranura para montaje sensores | 3 | Slot for proximity sensor |

XH

DOBLE EFECTO AMORTIGUADO MAGNÉTICO - DOUBLE ACTING CUSHIONED MAGNETIC

Ø mm.	ØB d11	VD	VA	L2	WH	ØMM	SW	KK	AM	SW1	ZJ	L8	BG	RT	SW2	E	TG	EE	PL	J3	J2	L7	SW3
32	30	10	4	20	26	12	10	M10X1.25	22	17	120	94	18	M6	6	46	32.5	G1/8	18	4	6.5	2	2.5
40	35	10.5	4	22	30	16	13	M12X1.25	24	19	135	105	18	M6	6	54	38	G1/4	17.5	3.5	8	5.8	2.5
50	40	11.5	4	28	37	20	17	M16X1.5	32	22	143	106	20	M8	8	64	46.5	G1/4	20.5	7	10	2	4
63	45	15	4	29	37	20	17	M16X1.5	32	22	158	121	20	M8	8	74	56.5	G3/8	22	11	8.5	4	4
80	45	15.7	4	35	46	25	22	M20X1.5	40	30	174	128	19	M10	6	94	72	G3/8	22	11	8.5	4	4
100	55	19.2	4	38	51.5	25	22	M20X1.5	40	30	189.5	138	19	M10	6	111	89	G1/2	26	9	12.5	5	4
125	60	20	6	50	65	32	27	M27X2	54	41	225	160	21	M12	8	135	110	G1/2	30	9	12.5	2.5	4

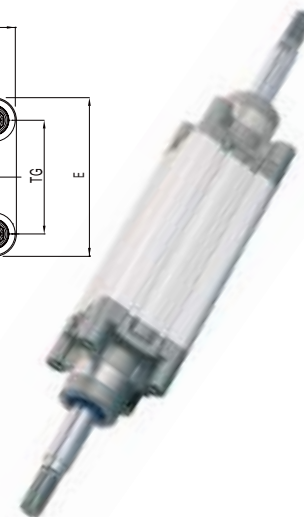
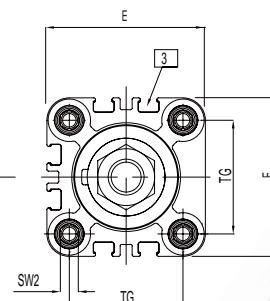
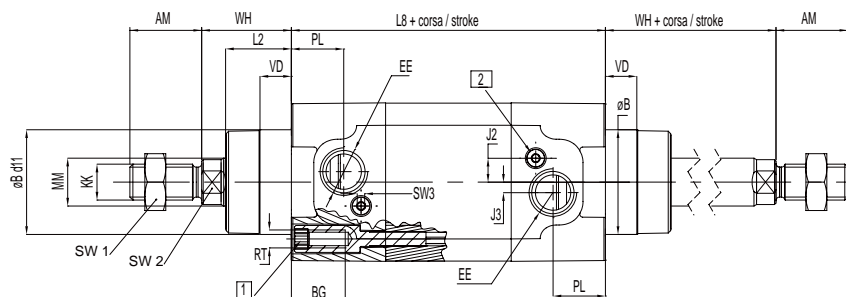

- | | | | |
|---|---|---|---|
| 1 | Tornillos con hexagono interior con rosca hembra para el montaje de los elementos de fijación y para el montaje directo | 1 | Socket head screw with female thread for mounting attachments |
| 2 | Tornillos para la regulación de la amortiguación | 2 | Regulating screw for adjustable end-position cushioning |
| 3 | Ranura para montaje sensores | 3 | Slot for proximity sensor |

XL

DOBLE EFECTO VÁSTAGO PASANTE AMORTIGUADO MAGNÉTICO - DOUBLE ACTING CUSHIONED MAGNETIC WITH DOUBLE ROD END

Ø mm.	ØB d11	VD	VA	L2	WH	ØMM	SW	KK	AM	SW1	ZJ	L8	BG	RT	SW2	E	TG	EE	PL	J3	J2	L7	SW3
32	30	10	4	20	26	12	10	M10X1.25	22	17	120	94	18	M6	6	46	32.5	G1/8	18	4	6.5	2	2.5
40	35	10.5	4	22	30	16	13	M12X1.25	24	19	135	105	18	M6	6	54	38	G1/4	17.5	3.5	8	5.8	2.5
50	40	11.5	4	28	37	20	17	M16X1.5	32	22	143	106	20	M8	8	64	46.5	G1/4	20.5	7	10	2	4
63	45	15	4	29	37	20	17	M16X1.5	32	22	158	121	20	M8	8	74	56.5	G3/8	22	11	8.5	4	4
80	45	15.7	4	35	46	25	22	M20X1.5	40	30	174	128	19	M10	6	94	72	G3/8	22	11	8.5	4	4
100	55	19.2	4	38	51.5	25	22	M20X1.5	40	30	189.5	138	19	M10	6	111	89	G1/2	26	9	12.5	5	4
125	60	20	6	50	65	32	27	M27X2	54	41	225	160	21	M12	8	135	110	G1/2	30	9	12.5	2.5	4

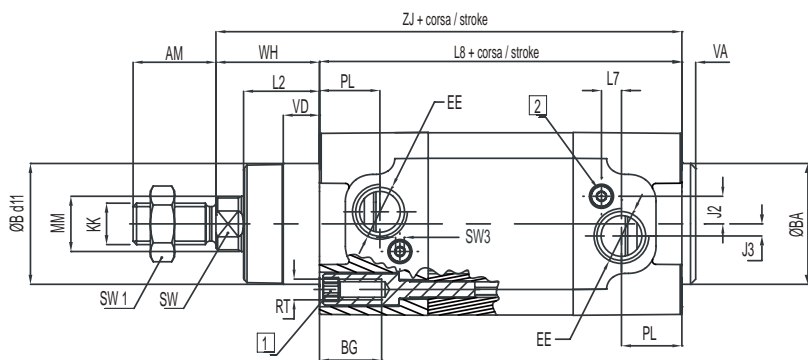

- | | |
|---|---|
| <p>1 Tornillos con hexagono interior con rosca hembra para el montaje de los elementos de fijación y para el montaje directo</p> <p>2 Tornillos para la regulación de la amortiguación</p> <p>3 Ranura para montaje sensores</p> | <p>1 Socket head screw with female thread for mounting attachments</p> <p>2 Regulating screw for adjustable end-position cushioning</p> <p>3 Slot for proximity sensor</p> |
|---|---|

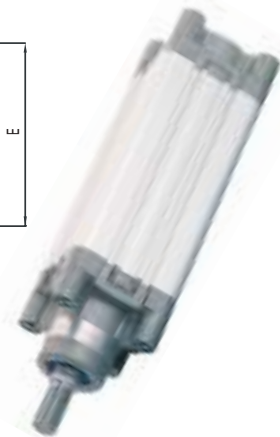

XB

SIMPLE EFECTO MAGNÉTICO - SINGLE-ACTING MAGNETIC

\varnothing mm.	$\varnothing B$ d_{11}	VD	VA	L2	WH	$\varnothing MM$	SW	KK	AM	SW1	ZJ	L8	BG	RT	SW2	E	TG	EE	PL	J3
32	30	10	4	20	26	12	10	M10X1.25	22	17	145	119	18	M6	6	46	32.5	G1/8	18	4
40	35	10.5	4	22	30	16	13	M12X1.25	24	19	160	130	18	M6	6	54	38	G1/4	17.5	3.5
50	40	11.5	4	28	37	20	17	M16X1.5	32	22	168	131	20	M8	8	64	46.5	G1/4	20.5	7
63	45	15	4	29	37	20	17	M16X1.5	32	22	183	146	20	M8	8	74	56.5	G3/8	22	8
80	45	15.7	4	35	46	25	22	M20X1.5	40	30	199	153	19	M10	6	94	72	G3/8	22	11
100	55	19.2	4	38	51.5	25	22	M20X1.5	40	30	214.5	163	19	M10	6	111	89	G1/2	26	9

Cilindros Iso 15552 con bloqueo de vástago / Cylinders Iso 15552 with Piston Rod Lock

La unidad de bloqueo sirve para inmovilizar el vástago en cualquier posición en caso de caída de la presión. En ausencia de alimentación neumática en el dispositivo de bloqueo, el vástago del cilindro es inmovilizado mecánicamente con una fuerza superior a la salida del cilindro alimentado a 10 bar. Es importante recordar que el vástago puede ser desbloqueado sólo cuando ambas cámaras están bajo presión.

The piston rod lock is a locking unit, which blocks the piston rod in any positions in case of pressure drop. In case of lack of air to the locking device, the cylinder piston rod is mechanically blocked with a bigger force that the thrust made by the cylinder fed at 10 bar. It is important to remember that the locking unit of the piston rod can be released only when both the barrels are under pressure.

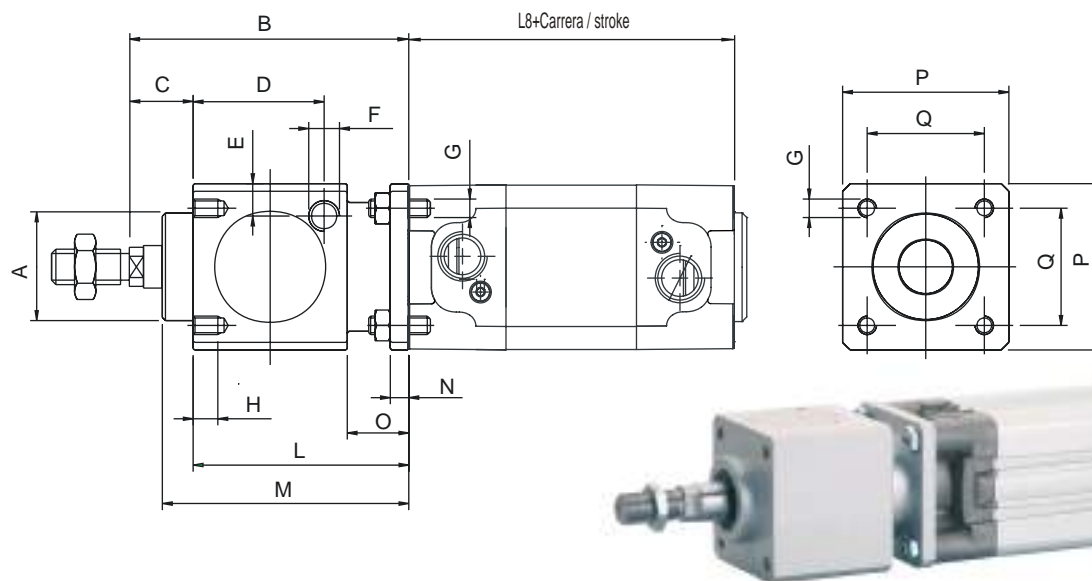

XHB

DOBLE EFECTO AMORTIGUADO MAGNÉTICO CON UNIDAD DE BLOQUEO - DOUBLE ACTING CUSHIONED MAGNETIC WITH PISTON ROD LOCK

Ø mm.	A	B	C	D	E	F	G	H	L	M	N	O	P	Q	L8
32	30	86	26	33.25	9	1/8"G	M6	8	60	67.5	6	20	47	32.5	94
40	34.5	100	30	42.5	9	1/8"G	M6	8	70	80	6	20	54	38	105
50	40	127	37	58	12.5	1/8"G	M8	12	90	100	8	24	65	46.5	106
63	45	127	37	59	17.5	1/8"G	M8	12	90	100	8	24	75	56.5	121
80	45	156	46	69	17.5	1/4"G	M10	16	110	120	12	32	95	72	128
100	55	161	51	69	20	1/4"G	M10	16	110	120	12	32	114	89	138
125	60	205	65	84.5	19	1/4"G	M12	20	140	156	20	45	138	110	160

XLB DISPONIBLE TAMBIÉN EN LA VERSIÓN VÁSTAGO PASANTE CON UNIDAD DE BLOQUEO - XLB AVAILABLE DOUBLE ROD END WITH PISTON ROD LOCK

Características Técnicas / Technical Characteristics

Presión mín. de Desbloqueo / Min. Release pressure

2.5 bar presión cilindro de 0 a 7 bar;
3 bar presión cilindro de 7 a 10 bar.

2.5 bar cylinder supply pressure from 0 to 7 bar;
3 bar cylinder supply pressure from 7 to 10 bar.

En ausencia de Presión / In absence of Pressure

Bloqueado.
Locked.

Fluidos compatibles / Fluids

Aire comprimido filtrado lubricado y no lubricado.
Filtered and lubricated compressed air as well as non lubricated air.

Temperaturas / Temperatures

Temperatura mínima / Minimum temperature: 0 °C
(-20 °C con aire seco / with dry air)
Temperatura máxima / Maximum temperature: +80 °C

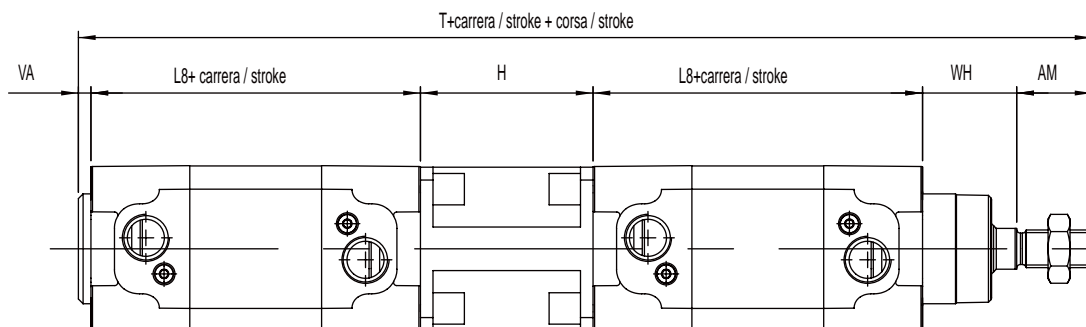

XHT

TÁNDEM DOBLE EFECTO MAGNÉTICO - TANDEM DOUBLE-ACTING MAGNETIC

Ø mm.	VA	WH	AM	L8	H	T
32	4	26	22	94	55	295
40	4	30	24	105	55	323
50	4	37	32	106	68	353
63	4	37	32	121	68	383
80	4	46	40	128	92	438
100	4	51.5	40	138	92	463.5
125	6	65	54	160	120	565

* PARA MAYOR INFORMACIÓN CONTACTAR NUESTRO DEPARTAMENTO TÉCNICO
 * FOR FURTHER INFORMATION PLEASE CONTACT OUR TECHNICAL DEPARTMENT

Cilindros Rotativos Serie X ISO 15552 / Rotary Cylinders X Serie ISO 15552

Los cilindros rotativos han sido diseñados para transformar el movimiento rectilíneo característico del cilindro neumático, en movimiento rotatorio a través de un engranaje cremallera-piñón. El cilindro adopta el mismo sistema de amortiguación neumática típico del cilindro tradicional y permite una regulación mecánica para ajustar el ángulo en +/- 5°.

The rotary cylinders are designed to translate the rectilinear motion, which is the characteristic motion of the pneumatic cylinders, into rotational motion by means of a gear, rack-pinion. The cylinders adopt the same pneumatic cushioning end position system typical of the traditional cylinders and they can have a mechanical adjust on the stop, which allows regulating the angulation of +/- 5°.



Características Técnicas / Technical Characteristics

Presiones / Pressures

Presión mínima / Minimum pressure: 1 bar (0.1 MPa)
Presión máxima / Maximum pressure: 10 bar (1 MPa)

Temperaturas / Temperatures

Temperatura mínima / Minimum temperature: 0 °C
 (-20 °C con aire seco / with dry air)
Temperatura máxima / Maximum temperature: +80 °C

Fluidos compatibles / Fluids

Aire comprimido filtrado lubricado y no lubricado.
 Filtered and lubricated compressed air as well as non lubricated air.

Funcionamiento / Functioning

Doble efecto amortiguado magnético con piñon macho
Doble efecto amortiguado magnético con conexión hembra
 Double-acting cushioned and magnetic with male pinion
 Double-acting cushioned and magnetic with female connection.

Diámetros / Bores

De 32 a 100 mm.
 From 32 to 100 mm.

Campo de regulación del ángulo / Adjustable angle

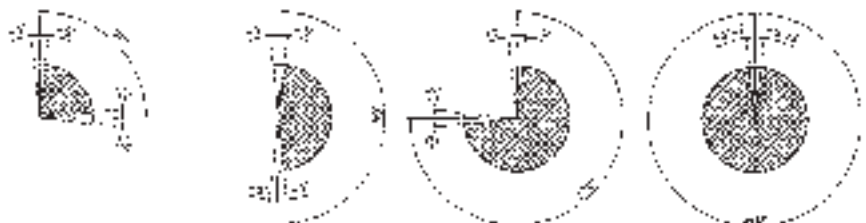

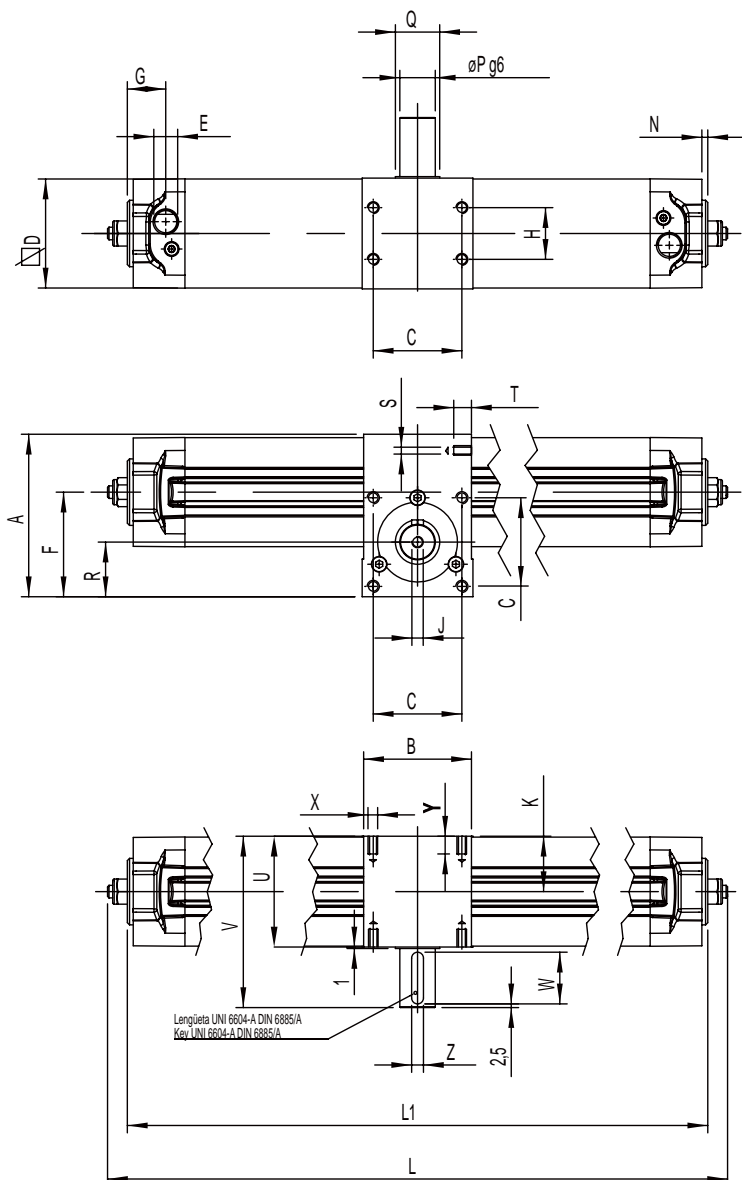
PAR DE FUERZAS A 1 BAR
TORQUE AT 1 BAR

Ø mm.	Nm
32	1.2
40	2.25
50	3.9
63	7.3
80	15.7
100	26.35

XRM

CILINDRO ROTATIVO MACHO CON REGULACIÓN DEL ÁNGULO +/- 5°
MALE ROTARY CYLINDER WITH ANGLE REGULATION +/- 5°

DIMENSIONES L Y L1 PARA ROTACIÓN - DIMENSIONS L AND L1 FOR ROTATIONS

Ø mm.	ROTACIÓN 90° 90° ROTATION		ROTACIÓN 180° 180° ROTATION		ROTACIÓN 270° 270° ROTATION		ROTACIÓN 360° 360° ROTATION	
	L	L1	L	L1	L	L1	L	L1
32	232	213	279	260	326	307	373	354
40	274	254	330	310	387	367	464	424
50	301	276	364	339	427	402	489	464
63	343	320	418	395	493	470	567	544
80	416	386	515	485	614	584	713	683
100	449	418	556	525	662	631	769	738

DIMENSIONES - DIMENSIONS

Ø mm.	A	B	C	D	E	F	G	H	J	K	N	P	Q	R	S	T	U	V	W	X	Y	Z
32	71.5	50	33	46	1/8 G	46.5	22	18	M5	25	4	14	25	25	M5	9	50	81	25	M6	10	5
40	82	60	40	54	1/4G	54.5	21.5	22	M5	30	4	14	25	30	M5	10	60	91	25	M6	10	5
50	94	70	50	64	1/4G	60.5	24.5	25	M6	32.5	4	19	30	32.5	M6	8	65	106	35	M8	13	6
63	110	75	60	74	3/8G	70.8	26	35	M8	37.5	4	24	30	37	M8	10	75	116	35	M8	13	8
80	142	99	80	94	3/8 G	93.5	26	50	M8	49.5	4	28	45	50	M9	12	99	150	45	M10	16	8
100	156.5	115	80	111	1/2 G	99	30	60	M10	57.5	4	38	50	54	M9	17	115	166	45	M10	16	10

ROTACIÓN STANDARD - STANDARD ROTATION

Ø mm.	90°	180°	270°	360°
32 - 40 - 50 - 63 - 80 - 100	X	X	X	X

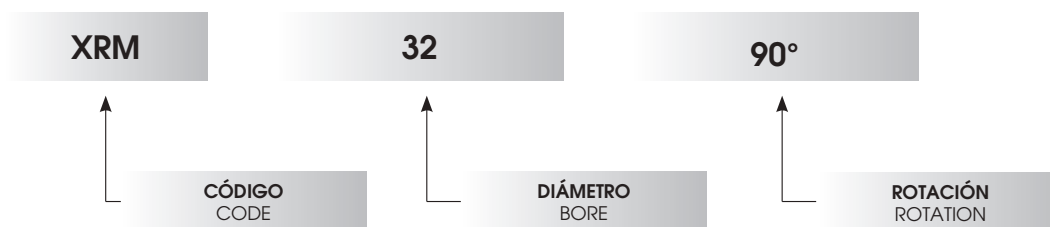
Ejemplo de pedido / How to Order

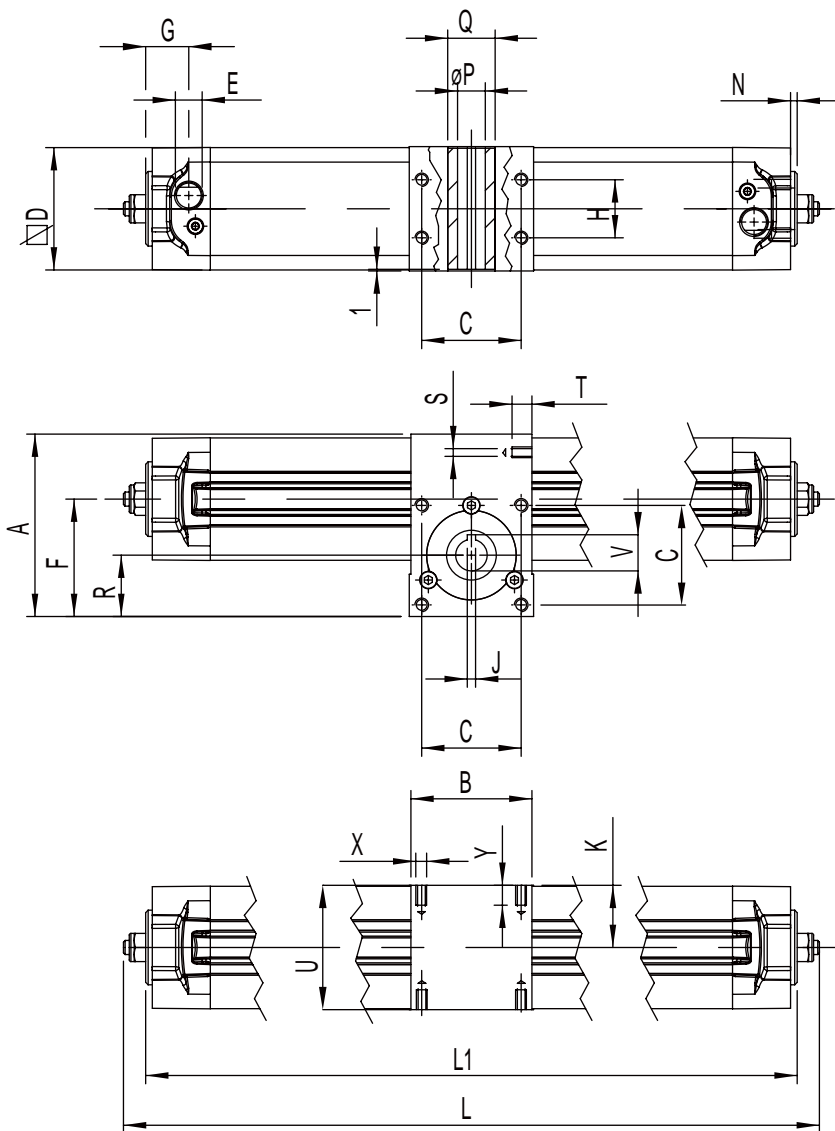

PAR DE FUERZAS A 1 BAR
TORQUE AT 1 BAR

Ø mm.	Nm
32	1.2
40	2.25
50	3.9
63	7.3
80	15.7
100	26.35

XRF

CILINDRO ROTATIVO HEMBRA CON REGULACIÓN DEL ÁNGULO +/- 5° FEMALE ROTARY CYLINDER WITH ANGLE REGULATION +/- 5°

DIMENSIONES L Y L1 PARA ROTACIÓN - DIMENSIONS L AND L1 FOR ROTATIONS

Ø mm.	ROTACIÓN 90° 90° ROTATION		ROTACIÓN 180° 180° ROTATION		ROTACIÓN 270° 270° ROTATION		ROTACIÓN 360° 360° ROTATION	
	L	L1	L	L1	L	L1	L	L1
32	232	213	279	260	326	307	373	354
40	274	254	330	310	387	367	464	424
50	301	276	364	339	427	402	489	464
63	343	320	418	395	493	470	567	544
80	416	386	515	485	614	584	713	683
100	449	418	556	525	662	631	769	738

DIMENSIONES - DIMENSIONS

Ø mm.	A	B	C	D	E	F	G	H	J	K	N	ØP	Q	R	S	T	U	V	X	Y
32	71.5	50	33	46	1/8 G	46.5	22	18	5	25	4	14	25	25	M5	9	50	16.3	M6	10
40	82	60	40	54	1/4 G	54.5	21.5	22	5	30	4	14	25	30	M5	10	60	16.3	M6	10
50	94	70	50	64	1/4 G	60.5	24.5	25	6	32.5	4	19	30	32.5	M6	8	65	21.8	M8	13
63	110	75	60	74	3/8 G	70.8	26	35	6	37.5	4	19	30	37	M8	10	75	21.8	M8	13
80	142	99	80	94	3/8 G	93.5	26	50	8	49.5	4	24	45	50	M9	12	99	27.3	M10	16
100	156.5	115	80	111	1/2 G	99	30	60	8	57.5	4	28	50	54	M9	17	115	31.3	M10	16

ROTACIÓN STANDARD - STANDARD ROTATION

Ø mm.	90°	180°	270°	360°
32 - 40 - 50 - 63 - 80 - 100	X	X	X	X

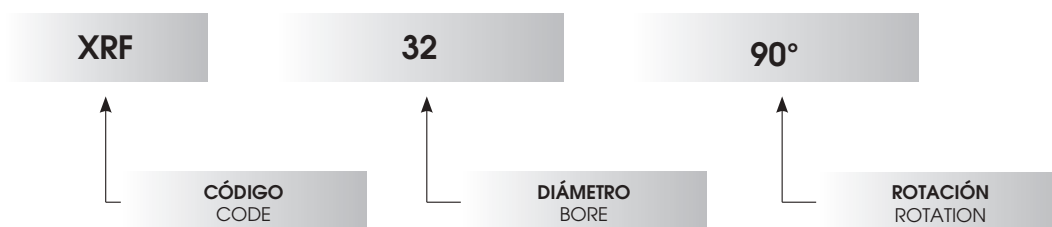
Ejemplo de pedido / How to Order

Cilindros Serie E ISO 6431 / Cylinder E Serie ISO 6431

Los cilindros de esta serie son realizados según la norma DIN ISO 6431.

Adaptables a la utilización en cualquier sector industrial.

Las elevadas características de deslizamiento aseguran la máxima productividad en las instalaciones.

Las tapas son realizadas en aluminio presofundido del Ø32 al Ø125, mientras son fundidas a coquilla del Ø160 al Ø320.

Los cilindros serie E pueden suministrarse con camisa de aluminio en dos configuraciones:

- Del Ø32 al Ø125 Camisa en aluminio denominada "G" con ranura longitudinal para la inserción de los sensores magnéticos.

- Del Ø32 al Ø320 Camisa en aluminio perfil redondo con tirantes.

The cylinders of this series are manufactured according to DIN ISO 6431.

They are suitable for use in any sector of industrial property.

The high flow characteristics ensure maximum productivity of the plants.

The heads are made from cast aluminum Ø32 to Ø125, while gravity casting from Ø160 to Ø320.

The cylinders of the E series can be supplied with aluminum tube in two configurations:

- From Ø32 to Ø125 Shirt aluminum called "G" with longitudinal slots for the insertion of the retractable sensor.

- From Ø32 to Ø320 shirt from aluminum rods with rounded profile.



Del Ø32 al Ø125.

Camisa en aluminio denominada "G" con ranura longitudinal para la inserción de los sensores magnéticos.

From Ø32 to Ø125.

Aluminum jacket called "G" with longitudinal slots for the insertion of the retractable sensor.



Del Ø32 al Ø320.

Camisa en aluminio perfil redondo con tirantes.

From Ø32 to Ø320.

Shirt aluminum rods with rounded profile.

Características Técnicas / Technical Characteristics

Presiones / Pressures

Presión mínima / Minimum pressure: **1 bar (0.1 MPa)**

Presión máxima / Maximum pressure: **10 bar (1 MPa)**

Temperaturas / Temperatures

Temperatura mínima / Minimum temperature: **0 °C**
(-20 °C con aire seco / with dry air)

Temperatura máxima / Maximum temperature: **+80 °C**

Fluidos compatibles / Fluids

Aire comprimido filtrado lubricado y no lubricado
Filtered and lubricated compressed air as well as non lubricated air.

Funcionamiento / Functioning

Doble efecto amortiguado magnético, Simple efecto magnético, Vástago simple o pasante amortiguado magnético.
Double-acting cushioned magnetic, Single-acting magnetic
Single or through piston rod magnetic.

Diámetros / Bores

De 32 a 320 mm.

From 32 to 320mm.

Carreras / Strokes

Carreras Standard / Standard Strokes
De 25 a 1000 mm / From 25 to 1000 mm

Carreras bajo Demanda / Stroke on Demand
Hasta 2700 mm / Up to 2700 mm

Características Técnicas / Technical Characteristics

Materiales utilizados para cilindro serie E con camisa en aluminio anodizado con ranuras.
Used Materials for cylinders Serie E with anodized aluminium Mikey-mouse profile and slots.

Diámetros / Diameter

32 - 40 - 50 - 63 - 80 - 100 - 125

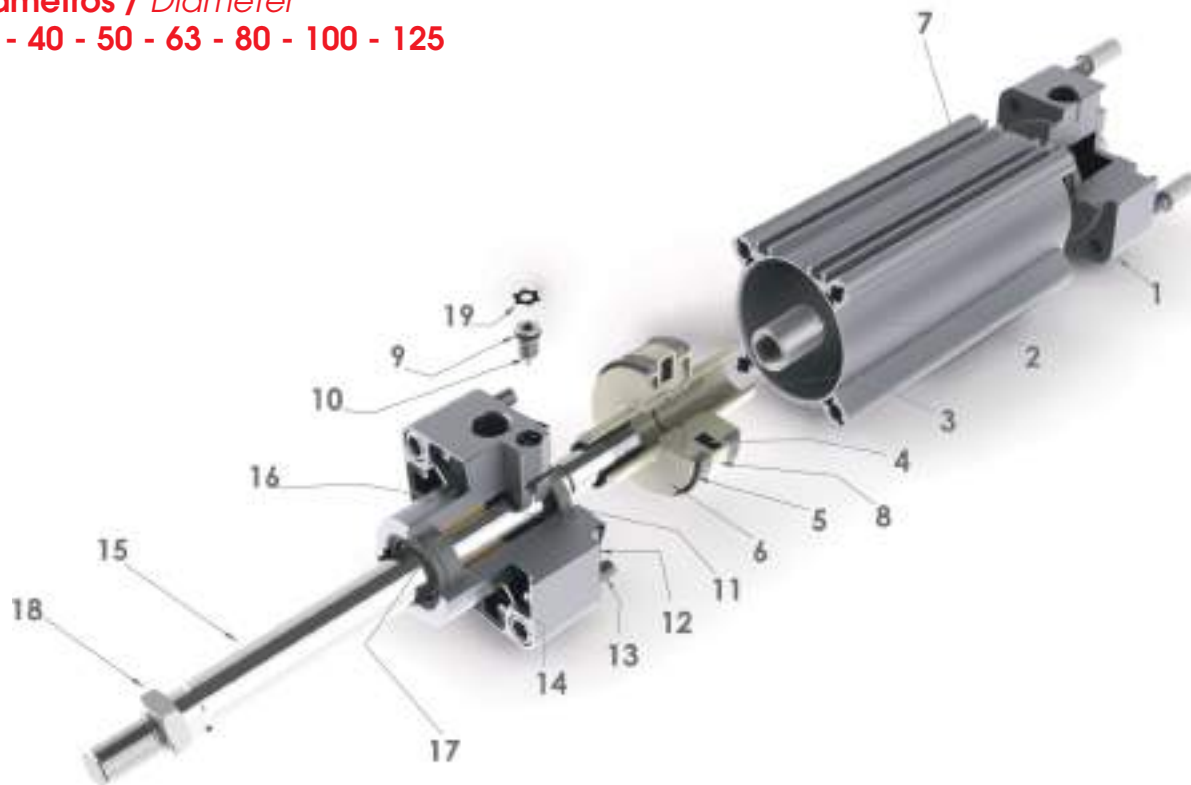

Materiales y Componentes / Component Parts and Materials

1 Tapa posterior Aluminio Presofundido con chorro de arena	1 Rear head Die-casted Sandblasted aluminium
2 Tuerca en Acero zincado y anodizado	2 Zinc-plated steel Nut
3 Junta tórica en Nbr o FKM	3 O-ring Nbr or FKM
4 Magnete en Plastroferrita	4 Magnet Bonded ferrite
5 Junta pistón en Poliuretano o FKM	5 Piston seal in Polyurethane or FKM
6 Pistón en Aluminio	6 Piston in Aluminium
7 Camisa en Aluminio anodizado	7 Tube Anodized aluminium
8 Guía pistón en Resina acetálica	8 Piston guide in Acetal resin
9 Junta tórica en Nbr o FKM	9 O-ring in Nbr o FKM
10 Tornillo amortiguador en Acero zincado	10 Cushioning screw Galvanized steel
11 Junta amortiguador en Poliuretano o FKM	11 Cushioning seal in Polyurethane or FKM
12 Tapa anterior en Aluminio Presofundido con chorro de arena	12 Front head Die-casted Sandblasted aluminium
13 Tornillos de fijación en Acero zincado	13 Fixing screw Galvanized steel
14 Junta vástago en Poliuretano o FKM	14 Rod seal in Polyurethane or FKM
15 Vástago en Acero cromado o Acero inox	15 Rod Chromium plated steel or Stainless steel
16 Junta tórica en Nbr o FKM	16 O-ring in Nbr or FKM
17 Cojinete en Bronce sinterizado	17 Bush in Sintered bronze
18 Tuerca vástago en Acero zincado	18 Rod nut Galvanized steel
19 Anillo elástico en Acero	19 Elastic ring made in steel

Fuerzas y Consumos / Forces And Consumptions

FUERZA DE EMPUJE Y TRACCIÓN - THRUST AND TRACTION FORCES

Ø Cilindro Ø Cylinder	Ø Vástago Ø Rod	Superficie útil en mm2 Working Surface in mm2	Presión de trabajo en bar Operating pressure in bar									
			1	2	3	4	5	6	7	8	9	10
			Fuerza desarrollada en N Output force in N									
Ø32	12	Empuje / Thrust = 804	72	144	216	288	360	432	504	576	648	720
		Tracción / Traction = 691	62	124	186	248	310	372	434	496	558	620
Ø40	16	Empuje / Thrust = 1257	110	220	330	440	550	660	770	880	990	1100
		Tracción / Traction = 1056	95	190	285	380	475	570	665	760	855	950
Ø50	20	Empuje / Thrust = 1963	175	350	525	700	875	1050	1225	1400	1575	1750
		Tracción / Traction = 1649	148	296	444	592	740	888	1036	1184	1332	1480
Ø63	20	Empuje / Thrust = 3117	280	560	840	1120	1400	1680	1960	2240	2520	2800
		Tracción / Traction = 2803	250	500	750	1000	1250	1500	1750	2000	2250	2500
Ø80	25	Empuje / Thrust = 5027	450	900	1350	1800	2250	2700	3150	3600	4050	4500
		Tracción / Traction = 4536	405	810	1215	1620	2025	2430	2835	3240	3645	4050
Ø100	25	Empuje / Thrust = 7854	700	1400	2100	2800	3500	4200	4900	5650	6360	7000
		Tracción / Traction = 7363	660	1320	1980	2640	3300	3960	4620	5280	5940	6600
Ø125	32	Empuje / Thrust = 12270	1104	2208	3312	4416	5520	6624	7728	8832	9936	11040
		Tracción / Traction = 11468	1032	2064	3096	4128	5160	6192	7224	8256	9288	10320

CONSUMO CILINDRO - CYLINDER AIR CONSUMPTION

Ø Cilindro Ø Cylinder	Ø Vástago Ø Rod	Superficie útil en mm2 Working Surface in mm2	Presión de trabajo en bar Operating pressure in bar									
			1	2	3	4	5	6	7	8	9	10
			Consumo aire en NL para cada 10mm. de carrera Air consumption in NL for each 10mm. of stroke									
Ø32	12	Empuje / Thrust = 804	0,016	0,024	0,032	0,040	0,048	0,056	0,064	0,072	0,080	0,088
		Tracción / Traction = 691	0,014	0,021	0,028	0,035	0,041	0,048	0,055	0,062	0,069	0,076
Ø40	16	Empuje / Thrust = 1257	0,025	0,038	0,050	0,063	0,075	0,088	0,101	0,113	0,126	0,138
		Tracción / Traction = 1056	0,021	0,032	0,042	0,053	0,063	0,074	0,084	0,095	0,106	0,116
Ø50	20	Empuje / Thrust = 1963	0,039	0,059	0,079	0,098	0,118	0,137	0,157	0,177	0,196	0,216
		Tracción / Traction = 1649	0,033	0,049	0,066	0,082	0,099	0,115	0,132	0,148	0,165	0,181
Ø63	20	Empuje / Thrust = 3117	0,062	0,094	0,125	0,156	0,187	0,218	0,249	0,281	0,312	0,343
		Tracción / Traction = 2803	0,056	0,084	0,112	0,140	0,168	0,196	0,224	0,252	0,280	0,308
Ø80	25	Empuje / Thrust = 5027	0,101	0,151	0,201	0,251	0,302	0,352	0,402	0,452	0,503	0,553
		Tracción / Traction = 4536	0,091	0,136	0,181	0,227	0,272	0,318	0,363	0,408	0,454	0,499
Ø100	25	Empuje / Thrust = 7854	0,157	0,236	0,314	0,393	0,471	0,550	0,628	0,707	0,785	0,864
		Tracción / Traction = 7363	0,147	0,221	0,295	0,368	0,442	0,515	0,589	0,663	0,736	0,810
Ø125	32	Empuje / Thrust = 12270	0,245	0,368	0,491	0,614	0,736	0,859	0,982	1,104	1,227	1,350
		Tracción / Traction = 11468	0,229	0,344	0,459	0,573	0,688	0,803	0,917	1,032	1,147	1,261

FUERZA DEL MUELLE - SPRING TRACTION FORCES

Ø Cilindro Ø Cylinder	Carga Muelle Load Spring	Carrera / Stroke				
		25	50	75	80	100
		Fuerza desarrollada en N Output force in N				
Ø32	Carga Muelle en Reposo / Load of spring at rest	50	41	33	31,5	24,5
	Carga Muelle Comprimido / Load of compressed spring	58	58	58	58	58
Ø40	Carga Muelle en Reposo / Load of spring at rest	52	43	34	32	25
	Carga Muelle Comprimido / Load of compressed spring	61	61	61	61	61
Ø50	Carga Muelle en Reposo / Load of spring at rest	92	77	64	60	49
	Carga Muelle Comprimido / Load of compressed spring	110	110	110	110	110
Ø63	Carga Muelle en Reposo / Load of spring at rest	92	77	64	60	49
	Carga Muelle Comprimido / Load of compressed spring	110	110	110	110	110
Ø80	Carga Muelle en Reposo / Load of spring at rest	117	98	79	75	59
	Carga Muelle Comprimido / Load of compressed spring	138	138	138	138	138
Ø100	Carga Muelle en Reposo / Load of spring at rest	117	98	79	75	59
	Carga Muelle Comprimido / Load of compressed spring	138	138	138	138	138

Tabla de códigos de pedido - Ordering codes

E	H	0 3 2	0 0 2 5	G	I S
<div style="float: right; border: 1px solid black; padding: 5px; width: 30%;"> <p>Variantes / Choices</p> <p>VS= Solo junta vástago en FKM VS= Only rod seal in FKM</p> <p>IS= Vástago inox IS= Stainless steel rod</p> <p>V= Todas las juntas en FKM V= All FKM seals</p> <p>R= Rascador metálico R= Metal scraper</p> </div> <div style="clear: both;"></div> <p>Tipo de montaje / Mounting style</p> <p>G= Camisa en aluminio perfil Mickey Mouse con ranuras G= Anodized aluminium tube Mickey-mouse profile with slots (32/125)</p>					
<p>Carreras mm.</p> <p>Cilindros a simple efecto - Carreras standard mm. = 25-50-75-80-100</p> <p>Cilindros a doble efecto amortiguado - Carreras standard mm.: 25-50-75-80-100-125-150-160-200-250-300-320-350-400-450-500-600-700-800-900-1000</p> <p>Bajo demanda carreras intermedias o superiores- Carrera máxima 2700 mm.</p>			<p>Stroke mm.</p> <p>Single acting cylinders - Standard strokes mm. = 25-50-75-80-100</p> <p>Double acting cylinders cushioned - Standard strokes mm.: 25-50-75-80-100-125-150-160-200-250-300-320-350-400-450-500-600-700-800-900-1000</p> <p>Intermediate or higher strokes are available upon request. - Maximum stroke 2700 mm.</p>		
<p>Diámetros mm. / Diameter mm.</p> <p>32-40-50-63-80-100-125</p>					
<p>Ejecución / Execution</p> <p>B= Simple efecto muelle anterior magnético / Single acting front spring magnetic (D.32-100)</p> <p>H= Doble efecto amortiguado magnético / Double acting single rod cushioned magnetic</p> <p>L= Doble efecto amortiguado vástago pasante magnético / Double acting double rod cushioned magnetic</p>					

SERIE E

CARRERAS STANDARD mm. - STD STROKES

Ø mm.	25	50	75	80	100	125	150	160	200	250	300	320	350	400	450	500	600	700	800	900	1000	
32	▲	●	▲	●	▲	●	▲	●	▲	●	▲	●	▲	●	▲	●	▲	●	▲	●	▲	●
40	▲	●	▲	●	▲	●	▲	●	▲	●	▲	●	▲	●	▲	●	▲	●	▲	●	▲	●
50	▲	●	▲	●	▲	●	▲	●	▲	●	▲	●	▲	●	▲	●	▲	●	▲	●	▲	●
63	▲	●	▲	●	▲	●	▲	●	▲	●	▲	●	▲	●	▲	●	▲	●	▲	●	▲	●
80	▲	●	▲	●	▲	●	▲	●	▲	●	▲	●	▲	●	▲	●	▲	●	▲	●	▲	●
100	▲	●	▲	●	▲	●	▲	●	▲	●	▲	●	▲	●	▲	●	▲	●	▲	●	▲	●
125	●	●	●	●	●	●	●	●	●	●	●	●	●	●	●	●	●	●	●	●	●	●

- ▲ **EB SIMPLE EFECTO MAGNÉTICO - SINGLE-ACTING MAGNETIC**
- **EH DOBLE EFECTO AMORTIGUADO MAGNÉTICO - DOUBLE ACTING CUSHIONED MAGNETIC**
- **EL DOBLE EFECTO VÁSTAGO PASANTE AMORTIGUADO MAGNÉTICO - DOUBLE ACTING CUSHIONED MAGNETIC WITH DOUBLE ROD END**

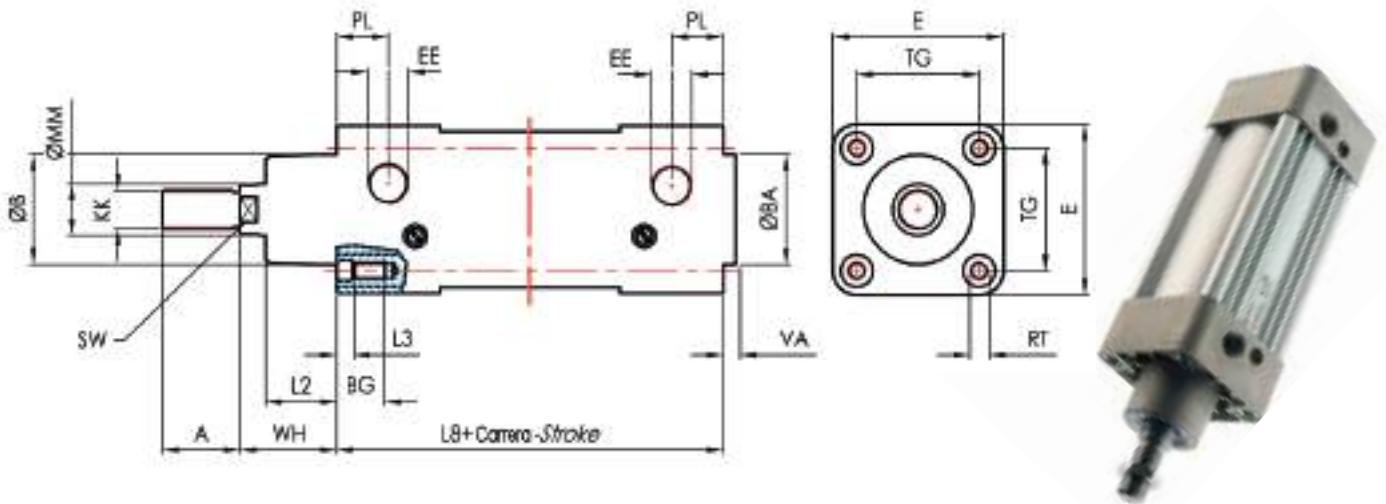

EH-----G

Camisa en aluminio perfil Mickey-mouse con ranuras.
Anodized aluminium tube Mickey-mouse profile with slots.

DOBLE EFECTO AMORTIGUADO MAGNÉTICO - DOUBLE ACTING CUSHIONED MAGNETIC

Ø mm.	ØB d11	VA	L2	WH	ØMM	SW	KK	A	L8	BG	RT	E	TG	EE	PL	L3	ZM
32	30	4	20	26	12	10	M10X1.2522	94	16	M6	47	32.5	G1/8	14	5	146	
40	35	4	22	30	16	13	M12X1.2524	105	16	M6	53	38	G1/4	16	5	165	
50	40	4	28	37	20	17	M16X1.532	106	16	M8	65	46.5	G1/4	21	5	180	
63	45	4	28	37	20	17	M16X1.532	121	16	M8	75	56.5	G3/8	22	5	195	
80	45	4	34	46	25	22	M20X1.540	128	17	M10	95	72	G3/8	23	6.5	220	
100	55	4	38	51.5	25	22	M20X1.540	138	17	M10	115	89	G1/2	26	6.5	240	
125	60	5	50	65	32	27	M27X2 54	160	20	M12	140	110	G1/2	30	6	290	

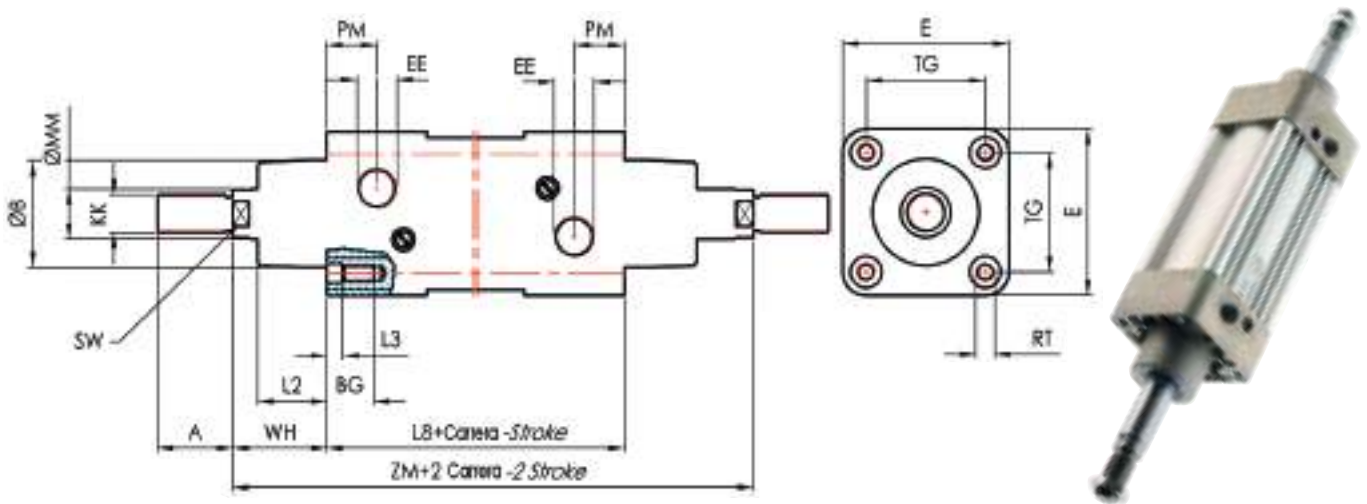

EL-----G

Camisa en aluminio perfil Mickey-mouse con ranuras.
Anodized aluminium tube Mickey-mouse profile with slots.

DOBLE EFECTO VÁSTAGO PASANTE AMORTIGUADO MAGNÉTICO-DOUBLE ACTING CUSHIONED MAGNETIC WITH DOUBLE ROD END

Ø mm.	ØBA d11	VA	L2	WH	ØMM	SW	KK	A	L8	BG	RT	E	TG	EE	PM	L3	ZM
32	30	4	20	26	12	10	M10X1.2522	94	16	M6	47	32.5	G1/8	14	5	146	
40	35	4	22	30	16	13	M12X1.2524	105	16	M6	53	38	G1/4	16	5	165	
50	40	4	28	37	20	17	M16X1.532	106	16	M8	65	46.5	G1/4	21	5	180	
63	45	4	28	37	20	17	M16X1.532	121	16	M8	75	56.5	G3/8	22	5	195	
80	45	4	34	46	25	22	M20X1.540	128	17	M10	95	72	G3/8	23	6.5	220	
100	55	4	38	51.5	25	22	M20X1.540	138	17	M10	115	89	G1/2	26	6.5	240	
125	60	5	50	65	32	27	M27X2 54	160	20	M12	140	110	G1/2	30	6	290	

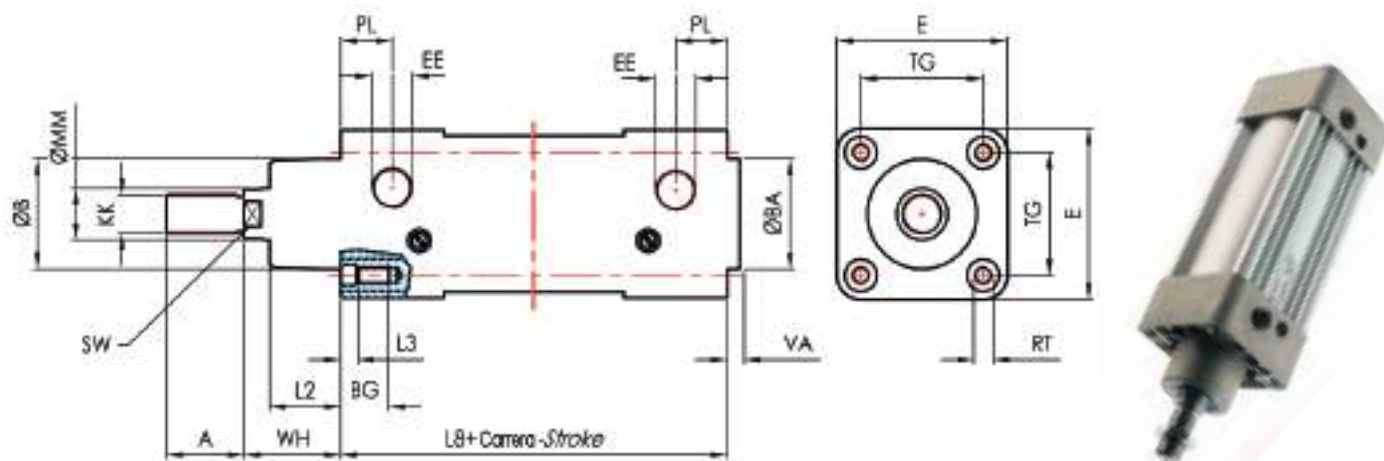

EB-----G

Camisa en aluminio perfil Mickey-mouse con ranuras.
Anodized aluminium tube Mickey-mouse profile with slots.

SIMPLE EFECTO MAGNÉTICO - SINGLE-ACTING MAGNETIC

Ø mm.	ØB ^{d11}	VA	L2	WH	ØMM	SW	KK	A	L8	BG	RT	E	TG	EE	PL	L3	ZM
32	30	4	20	26	12	10	M10X1.2522	94	16	M6	47	32.5	G1/8	14	5	146	
40	35	4	22	30	16	13	M12X1.2524	105	16	M6	53	38	G1/4	16	5	165	
50	40	4	28	37	20	17	M16X1.532	106	16	M8	65	46.5	G1/4	21	5	180	
63	45	4	28	37	20	17	M16X1.532	121	16	M8	75	56.5	G3/8	22	5	195	
80	45	4	34	46	25	22	M20X1.540	128	17	M10	95	72	G3/8	23	6.5	220	
100	55	4	38	51.5	25	22	M20X1.540	138	17	M10	115	89	G1/2	26	6.5	240	

Características Técnicas / Technical Characteristics

Materiales utilizados para cilindro serie E con camisa en aluminio anodizado a perfil redondo con tirantes
Used Materials for cylinders Serie E with anodized aluminium tube profile and tie rods.

Diámetros / Diameter

32 - 40 - 50 - 63 - 80 - 100 - 125 - 160 - 200 - 250 - 320

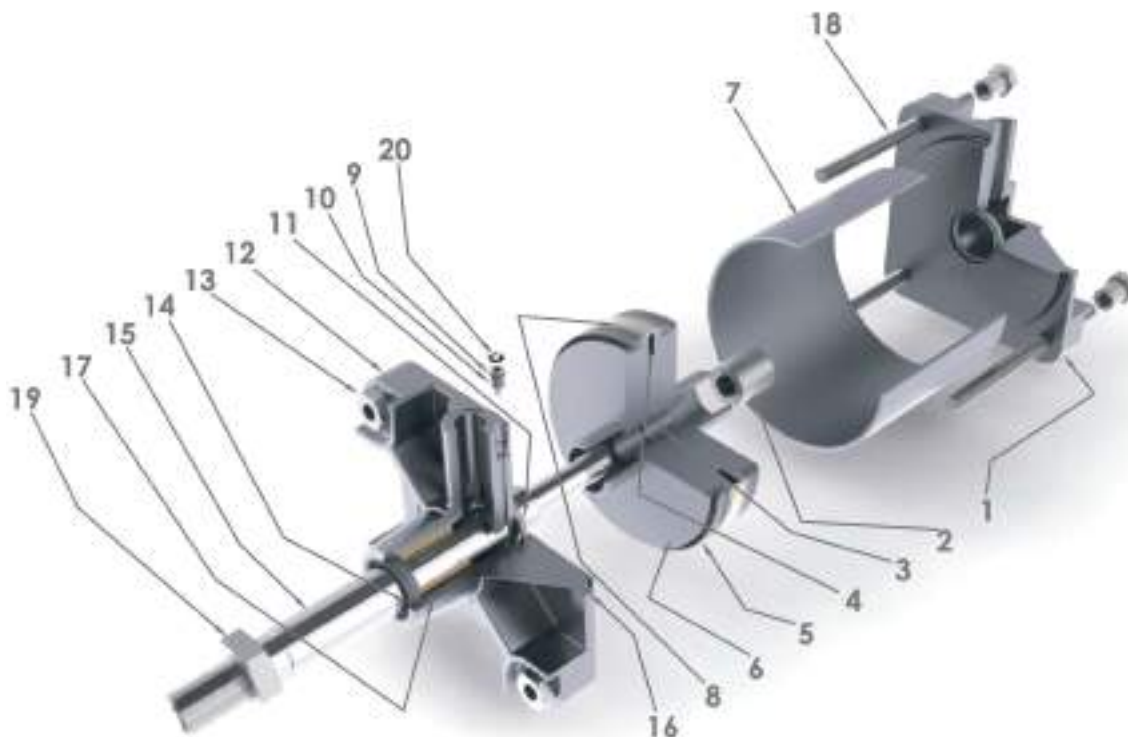

Materiales y Componentes / Component Parts and Materials

1 Tapa posterior Aluminio Presofundido con chorro de arena	1 Rear head Die-casted Sandblasted aluminium
2 Tuerca en Acero zincado y anodizado	2 Zinc-plated steel Nut
3 Junta tórica en Nbr o FKM	3 O-ring Nbr or FKM
4 Magnete en Plastroferrita	4 Magnet Bonded ferrite
5 Junta pistón en Poliuretano o FKM	5 Piston seal in Polyurethane or FKM
6 Pistón en Aluminio	6 Piston in Aluminium
7 Camisa en Aluminio anodizado	7 Tube Anodized aluminium
8 Guía pistón en Resina acetálica	8 Piston guide in Acetal resin
9 Junta tórica en Nbr o FKM	9 O-ring in Nbr o FKM
10 Tornillo amortiguador en Acero zincado	10 Cushioning screw Galvanized steel
11 Junta amortiguador en Poliuretano o FKM	11 Cushioning seal in Polyurethane or FKM
12 Tapa anterior en Aluminio Presofundido con chorro de arena	12 Front head Die-casted Sandblasted aluminium
13 Tornillos de fijación en Acero zincado	13 Fixing screw Galvanized steel
14 Junta vástago en Poliuretano o FKM	14 Rod seal in Polyurethane or FKM
15 Vástago en Acero cromado o Acero inox	15 Rod Chromium plated steel or Stainless steel
16 Junta tórica en Nbr o FKM	16 O-ring in Nbr or FKM
17 Cojinete en Bronce sinterizado	17 Bush in Sintered bronze
18 Tirantes en acero zincado	18 Tie rod Galvanized steel
19 Tuerca vástago en Acero zincado	19 Rod nut Galvanized steel
20 Anillo elástico en Acero	20 Elastic ring made in steel

Fuerzas y Consumos / Forces And Consumptions

FUERZA DE EMPUJE Y TRACCIÓN - THRUST AND TRACTION FORCES

Ø Cilindro Ø Cylinder	Ø Vástago Ø Rod	Superficie útil en mm ² Working Surface in mm ²	Presión de trabajo en bar Operating pressure in bar									
			1	2	3	4	5	6	7	8	9	10
			Fuerza desarrollada en N Output force in N									
Ø32	12	Empuje / Thrust = 804	72	144	216	288	360	432	504	576	648	720
		Tracción / Traction = 691	62	124	186	248	310	372	434	496	558	620
Ø40	16	Empuje / Thrust = 1257	110	220	330	440	550	660	770	880	990	1100
		Tracción / Traction = 1056	95	190	285	380	475	570	665	760	855	950
Ø50	20	Empuje / Thrust = 1963	175	350	525	700	875	1050	1225	1400	1575	1750
		Tracción / Traction = 1649	148	296	444	592	740	888	1036	1184	1332	1480
Ø63	20	Empuje / Thrust = 3117	280	560	840	1120	1400	1680	1960	2240	2520	2800
		Tracción / Traction = 2803	250	500	750	1000	1250	1500	1750	2000	2250	2500
Ø80	25	Empuje / Thrust = 5027	450	900	1350	1800	2250	2700	3150	3600	4050	4500
		Tracción / Traction = 4536	405	810	1215	1620	2025	2430	2835	3240	3645	4050
Ø100	25	Empuje / Thrust = 7854	700	1400	2100	2800	3500	4200	4900	5650	6360	7000
		Tracción / Traction = 7363	660	1320	1980	2640	3300	3960	4620	5280	5940	6600
Ø125	32	Empuje / Thrust = 12270	1104	2208	3312	4416	5520	6624	7728	8832	9936	11040
		Tracción / Traction = 11468	1032	2064	3096	4128	5160	6192	7224	8256	9288	10320
Ø160	40	Empuje / Thrust = 20096	1774	3548	5322	7097	8871	10645	12419	14194	15968	17742
		Tracción / Traction = 18840	1663	3326	4990	6653	8316	9980	11643	13307	14970	16633
Ø200	40	Empuje / Thrust = 31440	2772	5544	8316	11089	13861	16633	19406	22178	24950	27723
		Tracción / Traction = 30144	2661	5322	7984	10645	13307	15968	18629	21291	23952	26614
Ø250	50	Empuje / Thrust = 48750	4331	8663	12995	17326	21658	25990	30322	34653	38985	43317
		Tracción / Traction = 46800	4158	8316	12475	16663	20792	24950	29109	33267	37426	41584
Ø320	63	Empuje / Thrust = 78872	7097	14194	21291	28388	35485	42582	49679	56776	63873	70971
		Tracción / Traction = 76776	6822	13644	20466	27288	34110	40932	47754	54576	61398	68220

CONSUMO CILINDRO - CYLINDER AIR CONSUMPTION

Ø Cilindro Ø Cylinder	Ø Vástago Ø Rod	Superficie útil en mm ² Working Surface in mm ²	Presión de trabajo en bar Operating pressure in bar									
			1	2	3	4	5	6	7	8	9	10
			Consumo aire en NL para cada 10mm. de carrera Air consumption in NL for each 10mm. of stroke									
Ø32	12	Empuje / Thrust = 804	0,016	0,024	0,032	0,040	0,048	0,056	0,064	0,072	0,080	0,088
		Tracción / Traction = 691	0,014	0,021	0,028	0,035	0,041	0,048	0,055	0,062	0,069	0,076
Ø40	16	Empuje / Thrust = 1257	0,025	0,038	0,050	0,063	0,075	0,088	0,101	0,113	0,126	0,138
		Tracción / Traction = 1056	0,021	0,032	0,042	0,053	0,063	0,074	0,084	0,095	0,106	0,116
Ø50	20	Empuje / Thrust = 1963	0,039	0,059	0,079	0,098	0,118	0,137	0,157	0,177	0,196	0,216
		Tracción / Traction = 1649	0,033	0,049	0,066	0,082	0,099	0,115	0,132	0,148	0,165	0,181
Ø63	20	Empuje / Thrust = 3117	0,062	0,094	0,125	0,156	0,187	0,218	0,249	0,281	0,312	0,343
		Tracción / Traction = 2803	0,056	0,084	0,112	0,140	0,168	0,196	0,224	0,252	0,280	0,308
Ø80	25	Empuje / Thrust = 5027	0,101	0,151	0,201	0,251	0,302	0,352	0,402	0,452	0,503	0,553
		Tracción / Traction = 4536	0,091	0,136	0,181	0,227	0,272	0,318	0,363	0,408	0,454	0,499
Ø100	25	Empuje / Thrust = 7854	0,157	0,236	0,314	0,393	0,471	0,550	0,628	0,707	0,785	0,864
		Tracción / Traction = 7363	0,147	0,221	0,295	0,368	0,442	0,515	0,589	0,663	0,736	0,810
Ø125	32	Empuje / Thrust = 12270	0,245	0,368	0,491	0,614	0,736	0,859	0,982	1,104	1,227	1,350
		Tracción / Traction = 11468	0,229	0,344	0,459	0,573	0,688	0,803	0,917	1,032	1,147	1,261
Ø160	40	Empuje / Thrust = 20096	0,402	0,603	0,804	1,005	1,206	1,407	1,608	1,809	2,010	2,211
		Tracción / Traction = 18840	0,377	0,565	0,754	0,942	1,130	1,319	1,507	1,696	1,884	2,072
Ø200	40	Empuje / Thrust = 31440	0,628	0,942	1,256	1,570	1,884	2,198	2,512	2,826	3,140	3,454
		Tracción / Traction = 30144	0,603	0,904	1,206	1,507	1,809	2,110	2,412	2,713	3,014	3,316
Ø250	50	Empuje / Thrust = 48750	0,981	1,472	1,963	2,453	2,948	3,434	3,925	4,415	4,906	5,400
		Tracción / Traction = 46800	0,942	1,413	1,884	2,355	2,826	3,297	3,768	4,239	4,710	5,181
Ø320	63	Empuje / Thrust = 78872	1,610	2,411	3,215	4,020	4,820	5,626	6,430	7,234	8,038	8,843
		Tracción / Traction = 76776	1,545	2,320	3,100	3,863	4,630	5,408	6,181	6,954	7,726	8,450

FUERZA DEL MUELLE - SPRING TRACTION FORCES

Ø Cilindro Ø Cylinder	Carga Muelle Load Spring	Carrera / Stroke				
		25	50	75	80	100
		Fuerza desarrollada en N Output force in N				
Ø32	Carga Muelle en Reposo / Load of spring at rest	50	41	33	31,5	24,5
	Carga Muelle Comprimido / Load of compressed spring	58	58	58	58	58
Ø40	Carga Muelle en Reposo / Load of spring at rest	52	43	34	32	25
	Carga Muelle Comprimido / Load of compressed spring	61	61	61	61	61
Ø50	Carga Muelle en Reposo / Load of spring at rest	92	77	64	60	49
	Carga Muelle Comprimido / Load of compressed spring	110	110	110	110	110
Ø63	Carga Muelle en Reposo / Load of spring at rest	92	77	64	60	49
	Carga Muelle Comprimido / Load of compressed spring	110	110	110	110	110
Ø80	Carga Muelle en Reposo / Load of spring at rest	117	98	79	75	59
	Carga Muelle Comprimido / Load of compressed spring	138	138	138	138	138
Ø100	Carga Muelle en Reposo / Load of spring at rest	117	98	79	75	59
	Carga Muelle Comprimido / Load of compressed spring	138	138	138	138	138

Tabla de códigos de pedido - Ordering codes

E	H	0 3 2	0 0 2 5	G	I S
					Variantes / Choices VS= Solo junta vástago en FKM <i>VS= Only rod seal in FKM</i> IS= Vástago inox <i>IS= Stainless steel rod</i> V= Todas las juntas en FKM <i>V= All FKM seals</i> R= Rascador metálico <i>R= Metal scraper</i>
					Tipo de montaje / Mounting style T= Camisa aluminio perfil redondo con tirantes <i>T= Anodized aluminium tube round profile with tie rods (32/320) with tie rods (32/320) mm.</i>
				Carrera mm. Cilindros a simple efecto - Carreras standard mm. = 25-50-75-80-100 Cilindros a doble efecto amortiguado - Carreras standard mm.: 25-50-75-80-100-125-150-160-200-250-300-320-350-400-450-500-600-700-800-900-1000 Bajo demanda carreras intermedias o superiores- Carrera máxima 2700 mm.	Stroke mm. <i>Single acting cylinders - Standard strokes mm. = 25-50-75-80-100</i> <i>Double acting cylinders cushioned - Standard strokes mm.:</i> <i>25-50-75-80-100-125-150-160-200-250-300-320-350-400-450-500-600-700-800-900-1000</i> <i>Intermediate or higher strokes are available upon request. - Maximum stroke 2700 mm.</i>
					Diámetros mm. / Diameter mm. 32-40-50-63-80-100-125-160-200-250-320
					Ejecución / Execution B= Simple efecto muelle anterior magnético / Single acting front spring magnetic (D.32-100) H= Doble efecto amortiguado magnético / Double acting single rod cushioned magnetic L= Doble efecto amortiguado vástago pasante magnético / Double acting double rod cushioned magnetic

SERIE E

CARRERAS STANDARD mm. - STD STROKES

Ø mm.	25	50	75	80	100	125	150	160	200	250	300	320	350	400	450	500	600	700	800	900	1000	
32	▲●	▲●	▲●	▲●	▲●	●	●	●	●	●	●	●	●	●	●	●	●	●	●	●	●	●
40	▲●	▲●	▲●	▲●	▲●	●	●	●	●	●	●	●	●	●	●	●	●	●	●	●	●	●
50	▲●	▲●	▲●	▲●	▲●	●	●	●	●	●	●	●	●	●	●	●	●	●	●	●	●	●
63	▲●	▲●	▲●	▲●	▲●	●	●	●	●	●	●	●	●	●	●	●	●	●	●	●	●	●
80	▲●	▲●	▲●	▲●	▲●	●	●	●	●	●	●	●	●	●	●	●	●	●	●	●	●	●
100	▲●	▲●	▲●	▲●	▲●	●	●	●	●	●	●	●	●	●	●	●	●	●	●	●	●	●
125	●	●	●	●	●	●	●	●	●	●	●	●	●	●	●	●	●	●	●	●	●	●
160	●	●	●	●	●	●	●	●	●	●	●	●	●	●	●	●	●	●	●	●	●	●
200	●	●	●	●	●	●	●	●	●	●	●	●	●	●	●	●	●	●	●	●	●	●
250	●	●	●	●	●	●	●	●	●	●	●	●	●	●	●	●	●	●	●	●	●	●
320	●	●	●	●	●	●	●	●	●	●	●	●	●	●	●	●	●	●	●	●	●	●

▲ EB SIMPLE EFECTO MAGNÉTICO - SINGLE-ACTING MAGNETIC

● EH DOBLE EFECTO AMORTIGUADO MAGNÉTICO - DOUBLE ACTING CUSHIONED MAGNETIC

● EL DOBLE EFECTO VÁSTAGO PASANTE AMORTIGUADO MAGNÉTICO - DOUBLE ACTING CUSHIONED MAGNETIC WITH DOUBLE ROD END

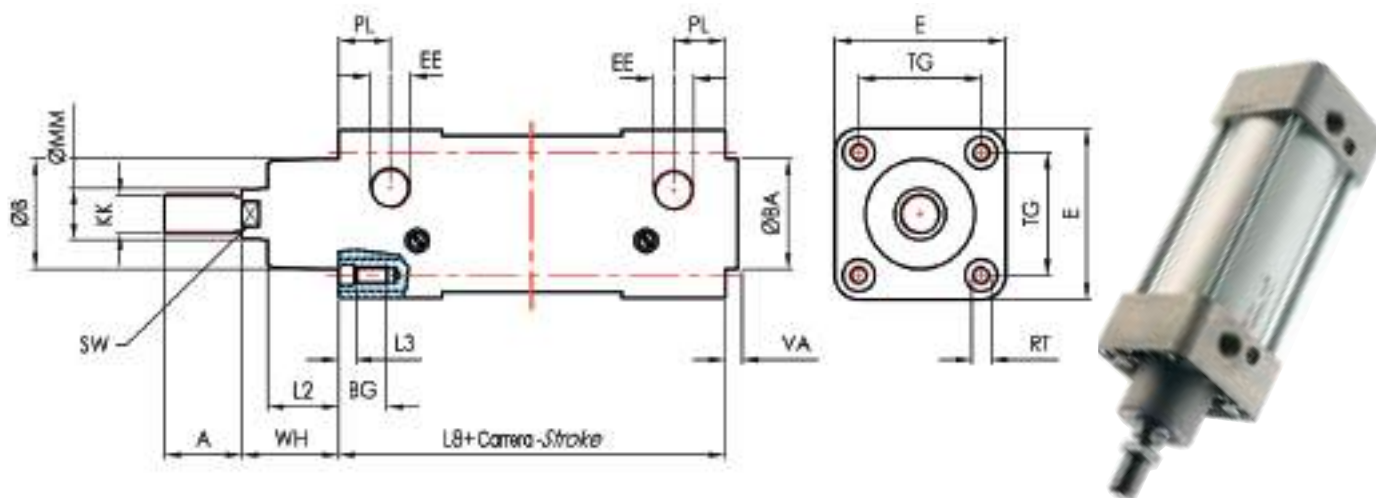

EH-----T

Camisa en aluminio a perfil redondo con tirantes.
Anodized aluminium tube round profile with tie rods

DOBLE EFECTO AMORTIGUADO MAGNÉTICO - DOUBLE ACTING CUSHIONED MAGNETIC

Ø mm.	ØB ^{d11}	VA	L2	WH	ØMM	SW	KK	A	L8	BG	RT	E	TG	EE	PL	L3	ZM
32	30	4	20	26	12	10	M10X1.2522	94	16	M6	47	32.5	G1/8	14	5	146	
40	35	4	22	30	16	13	M12X1.2524	105	16	M6	53	38	G1/4	16	5	165	
50	40	4	28	37	20	17	M16X1.532	106	16	M8	65	46.5	G1/4	21	5	180	
63	45	4	28	37	20	17	M16X1.532	121	16	M8	75	56.5	G3/8	22	5	195	
80	45	4	34	46	25	22	M20X1.540	128	17	M10	95	72	G3/8	23	6.5	220	
100	55	4	38	51.5	25	22	M20X1.540	138	17	M10	115	89	G1/2	26	6.5	240	
125	60	5	50	65	32	27	M27X2 54	160	20	M12	140	110	G1/2	30	6	290	
160	65	6	55	80	40	36	M36X2 72	180	24	M16	180	140	G3/4	29	0	340	
200	75	6	60	95	40	36	M36X2 72	180	24	M16	220	175	G3/4	29	0	370	
250	90	10	75	105	50	46	M42X2 84	200	25	M20	275	220	G1"	31	0	410	
320	110	10	90	120	63	55	M48X2 96	220	28	M24	350	270	G1"	31	0	460	

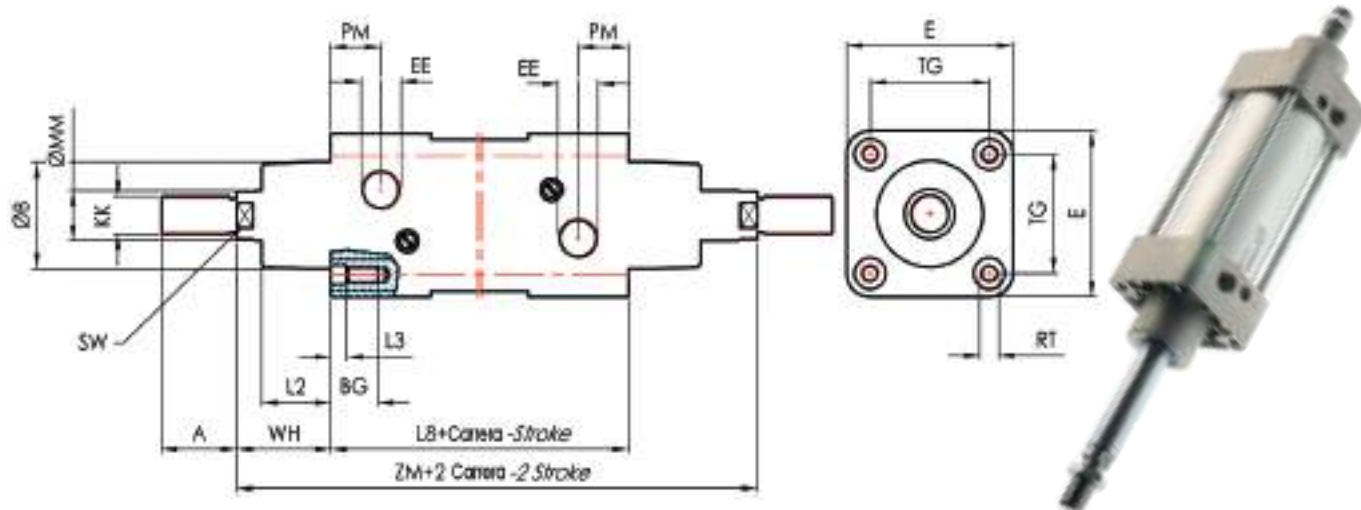

EL-----T

Camisa en aluminio a perfil redondo con tirantes.
Anodized aluminium tube round profile with tie rods

DOBLE EFECTO VÁSTAGO PASANTE AMORTIGUADO MAGNÉTICO - DOUBLE ACTING CUSHIONED MAGNETIC WITH DOUBLE ROD END

Ø mm.	ØBA d11	VA	L2	WH	ØMM	SW	KK	A	L8	BG	RT	E	TG	EE	PM	L3	ZM
32	30	4	20	26	12	10	M10X1.2522	94	16	M6	47	32.5	G1/8	14	5	146	
40	35	4	22	30	16	13	M12X1.2524	105	16	M6	53	38	G1/4	16	5	165	
50	40	4	28	37	20	17	M16X1.532	106	16	M8	65	46.5	G1/4	21	5	180	
63	45	4	28	37	20	17	M16X1.532	121	16	M8	75	56.5	G3/8	22	5	195	
80	45	4	34	46	25	22	M20X1.540	128	17	M10	95	72	G3/8	23	6.5	220	
100	55	4	38	51.5	25	22	M20X1.540	138	17	M10	115	89	G1/2	26	6.5	240	
125	60	5	50	65	32	27	M27X2.54	160	20	M12	140	110	G1/2	30	6	290	
160	65	6	55	80	40	36	M36X2.72	180	24	M16	180	140	G3/4	29	0	340	
200	75	6	60	95	40	36	M36X2.72	180	24	M16	220	175	G3/4	29	0	370	
250	90	10	75	105	50	46	M42X2.84	200	25	M20	275	220	G1"	31	0	410	
320	110	10	90	120	63	55	M48X2.96	220	28	M24	350	270	G1"	31	0	460	

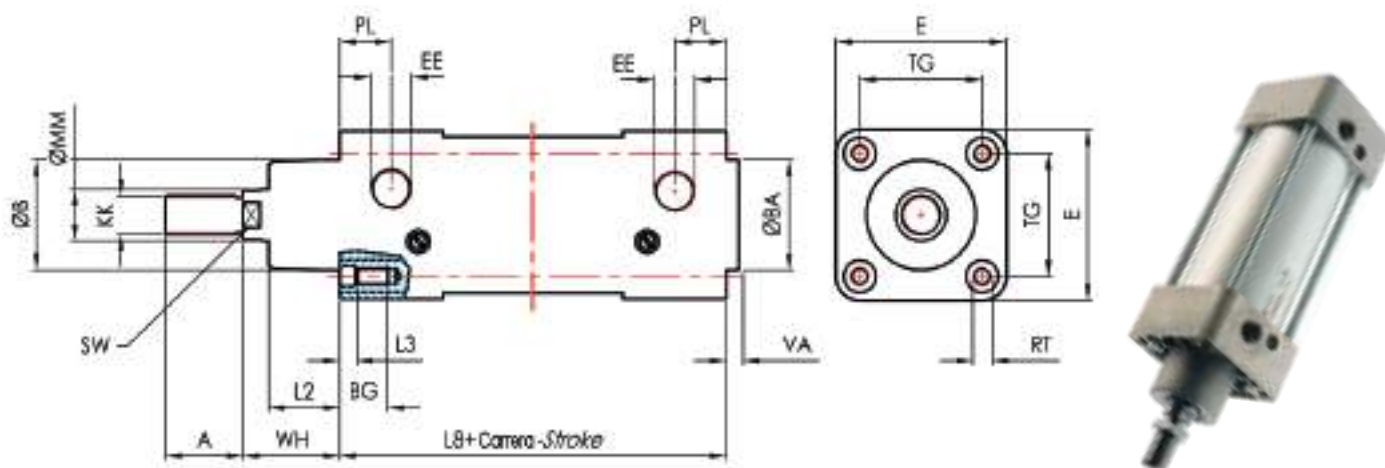

EB-----T

Camisa en aluminio a perfil redondo con tirantes.
Anodized aluminium tube round profile with tie rods

SIMPLE EFECTO MAGNÉTICO - SINGLE-ACTING MAGNETIC

Ø mm.	ØB d11	VA	L2	WH	ØMM	SW	KK	A	L8	BG	RT	E	TG	EE	PL	L3	ZM
32	30	4	20	26	12	10	M10X1.2522	94	16	M6	47	32.5	G1/8	14	5	146	
40	35	4	22	30	16	13	M12X1.2524	105	16	M6	53	38	G1/4	16	5	165	
50	40	4	28	37	20	17	M16X1.532	106	16	M8	65	46.5	G1/4	21	5	180	
63	45	4	28	37	20	17	M16X1.532	121	16	M8	75	56.5	G3/8	22	5	195	
80	45	4	34	46	25	22	M20X1.540	128	17	M10	95	72	G3/8	23	6.5	220	
100	55	4	38	51.5	25	22	M20X1.540	138	17	M10	115	89	G1/2	26	6.5	240	

Cilindros INOX Serie V Iso 15552 / INOX Cylinder V Serie Iso 15552

Los cilindros de esta serie son realizados completamente en acero INOX y respetan la normativa ISO 15552. Son construidos con las tapas y camisa en acero INOX AISI 304, mientras el vástago, los tirantes, los tornillos de fijación y los tornillos de amortiguación son en acero INOX 316. Estos cilindros son adecuados para ser empleados en ambientes particularmente agresivos, tales como el químico, farmacéutico, petroquímico, naval, agroalimentario, zootécnico, y aplicaciones en

These cylinders are entirely made of stainless steel and follow ISO 15552 normative. They are specifically manufactured with AISI 304 stainless steel heads and tube, while rod, tie rods, fixing screws and cushioning screws are made of AISI 316 stainless steel. These cylinders are suitable for particularly aggressive environments such as chemical, pharmaceutical, petrol chemical, navy, agro-food, zoo technical and outside employment.



Características Técnicas / Technical Characteristics

Presiones / Pressures

Presión mínima / Minimum pressure: **1 bar (0.1 MPa)**
 Presión máxima / Maximum pressure: **10 bar (1 MPa)**

Temperaturas / Temperatures

Temperatura mínima / Minimum temperature: 0 °C
 (-20 °C con aire seco / with dry air)
 Temperatura máxima / Maximum temperature: +80 °C

Fluidos compatibles / Fluids

Aire comprimido filtrado lubricado y no lubricado
 Filtered and lubricated compressed air as well as non lubricated air.

Funcionamiento / Functioning

Doble efecto amortiguado magnético, Simple efecto magnético, Vástago simple o pasante amortiguado magnético, Tándem.
 Double-acting cushioned magnetic, Single-acting magnetic Single or through piston rod magnetic, Tandem.

Diámetros / Bores

De 32 a 125 mm.
 From 32 to 125 mm.

Carreras / Strokes

Carreras Standard / Standard Strokes
 De 25 a 1000 mm / From 25 to 1000 mm

Carreras bajo Demanda / Stroke on Demand
 De 1000 a 2700 mm / From 1000 to 2700 mm

Tabla de códigos de pedido - Ordering codes

V	H	I	0 3 2	0 0 2 5	V S	Variantes / Choices
			Diámetro mm. <i>Diameter mm.</i> 32-40-50-63-80-100-125	Carrera mm. Cilindros a doble efecto amortiguado - Carreras standard mm.: 25-50-75-80-100-125-150-160-200-250-300- 320-350-400-450-500-600-700-800-900-1000 Bajo demanda carreras intermedias o superiores- Carrera máxima 2700 mm.	Stroke mm. Double acting cylinders cushioned - Standard strokes mm.: 25-50-75-80-100-125-150-160-200-250-300-320- 350-400-450-500-600-700-800-900-1000 Intermediate or higher strokes are available upon request. - Maximum stroke 2700 mm.	VS= Solo junta vástago en FKM VS= Only rod seal in FKM V= Todas las juntas en FKM V= All FKM seals
		I= INOX I= STAINLESS STEEL				

Ejecución / Execution

- G=** Doble efecto amortiguado no magnético / Double acting single rod cushioned without magnet
- H=** Doble efecto amortiguado magnético / Double acting single rod cushioned magnetic
- L=** Doble efecto amortiguado vástago pasante magnético / Double acting double rod cushioned magnetic
- K=** Doble efecto amortiguado vástago pasante no magnético / Double acting double rod cushioned without magnet

SERIE V

Cilindros de vástagos paralelos Serie NHA ISO 15552/ *Twin piston rod* *Cylinder NHA Serie Iso 15552*

Los cilindros de vástagos gemelos antirotación están diseñados bajo la normativa interface ISO 15552. Permiten de posicionar piezas con orientación perfectamente definida y con buena precisión porque la brida de unión está rigidamente colocada sobre los dos vástagos los cuales son guiados por cojinetes teflonados autolubrificantes en PTFE de mucha precisión. Este concepto constructivo no consiente la rotación durante la translación y establece una buena rigidez a la brida de unión permitiendo la aplicación de pequeñas cargas. Las tapas se presentan muy robustas y de óptimo aspecto estético y son realizadas en aluminio presofundido barnizado. Todas las juntas dinámicas son en poliuretano, que a diferencia del NBR garantizan mayor performance y mayor durabilidad en el tiempo. La camisa es en aluminio anodizado interno-externo a perfil con ranuras longitudinales para la inserción de los sensores magnéticos (D.32-100). Los vástagos son previstos en su versión standard en acero cromado, mientras son disponibles bajo demanda en acero inox. En la versión standard los amortiguadores de final de carrera son regulables y el pistón es magnético.

ISO 15552 twin rods antirotation cylinders. These cylinders allow any parts positioning with good precision and well defined orientation because the junction flange is strictly placed on two rods, guided by very precise PTFE self lubricating Teflon bushes. This constructive concept don't allows rotation during translation and grants a good rigidity to the flange, allowing small loads application. Heads are very strong and have a good looking, they are realized from die casted painted aluminum. Important is the whole dynamic seals in polyurethane, unlike NBR seals, they grant better performances and longer lasting. Tube inside-outside is made of anodized aluminum and may be supplied as follows: Profile with longitudinal slots, for magnetic sensor total insertion (0.32-100); Standard version rod is made of chromed steel; upon request stainless steel rods are also available. End stroke cushioning is adjustable on both sides for standard version and piston is magnetic.



Características Técnicas / Technical Characteristics

Presiones / Pressures

Presión mínima / Minimum pressure: 1 bar (0.1 MPa)
Presión máxima / Maximum pressure: 10 bar (1 MPa)

Temperaturas / Temperatures

Temperatura mínima / Minimum temperature: 0 °C
 (-20 °C con aire seco / with dry air)
Temperatura máxima / Maximum temperature: +80 °C

Fluidos compatibles / Fluids

Aire comprimido filtrado lubricado y no lubricado
Filtered and lubricated compressed air as well as non lubricated air.

Funcionamiento / Functioning

Doble efecto amortiguado magnético, Vástago simple o pasante amortiguado magnético.
*Double-acting cushioned magnetic
 Single or through piston rod magnetic.*

Diámetros / Bores

De 32 a 100 mm.
From 32 to 100 mm.

Carreras / Strokes

Carreras Standard / Standard Strokes
De 25 a 1000 mm / From 25 to 1000 mm

Carreras bajo Demanda / Stroke on Demand

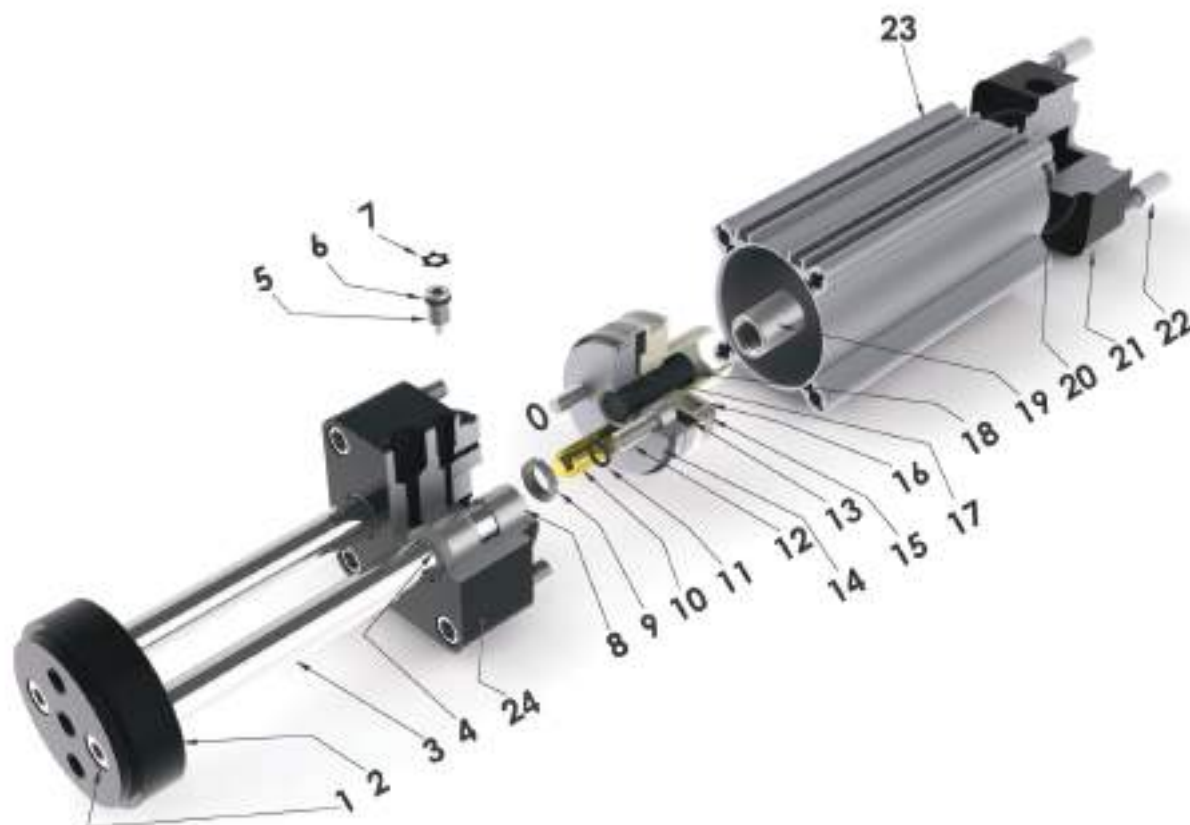
Características Técnicas / Technical Characteristics

Materiales y Componentes / Component Parts and Materials

1 Tornillos allen en acero zincado	1 Fixing screw Galvanized steel
2 Brida en aluminio anodizado	2 Anodized Aluminium Flange
3 Vástagos en Acero cromado o Acero inox	3 Rods Chromium plated steel or Stainless steel
4 Junta vástagos en Poliuretano	4 Rod seal in Polyurethane
5 Tornillo amortiguador en Acero zincado	5 Cushioning screw Galvanized steel
6 Junta tórica en Nbr	6 O-ring Nbr
7 Anillo elástico en Acero	7 Elastic ring made in steel
8 Cojinetes en acero teflonato PTFE	8 Steel with PTFE Bearing
9 Junta amortiguador en Poliuretano	9 Cushioning seal in Polyurethane
10 Cono amortiguador en latón	10 Brass cushioning cone
11 Junta tórica en Nbr	11 O-ring Nbr
12 Tornillos allen en acciaio zincado	12 Fixing screw Galvanized steel
13 Magnete en Plastroferrita	13 Magnet Bonded ferrite
14 Pistón anterior en Aluminio	14 Aluminium Front Piston
15 Junta pistón en Poliuretano	15 Piston seal in Polyurethane
16 Pistón posterior en resina acetálica	14 Acetal resin rear Piston
17 Junta tórica en Nbr	17 O-ring Nbr
18 Tornillo en acero	18 Steel Grub screw
19 Tuerca en acero zincado	19 Galvanized steel nut
20 Junta amortiguador en Poliuretano	20 Cushioning seal in Polyurethane
21 Tapa Posterior en Aluminio Presofundido	21 Rear head Die-casted aluminium
22 Tornillos de fijación en acero zincado	22 Fixing screw Galvanized steel
23 Camisa en Aluminio anodizado	23 Tube Anodized aluminium
24 Tapa Anterior en Aluminio Presofundido	24 Front head Die-casted aluminium

Fuerzas y Consumos / Forces And Consumptions

FUERZA DE EMPUJE Y TRACCIÓN - THRUST AND TRACTION FORCES

Ø Cilindro Ø Cylinder	Ø Vástago Ø Rod	Superficie útil en mm2 Working Surface in mm2	Presión de trabajo en bar Operating pressure in bar									
			1	2	3	4	5	6	7	8	9	10
			Fuerza desarrollada en N Output force in N									
Ø32	12	Empuje / Thrust = 804	72	144	216	288	360	432	504	576	648	720
		Tracción / Traction = 691	62	124	186	248	310	372	434	496	558	620
Ø40	16	Empuje / Thrust = 1257	110	220	330	440	550	660	770	880	990	1100
		Tracción / Traction = 1056	95	190	285	380	475	570	665	760	855	950
Ø50	20	Empuje / Thrust = 1963	175	350	525	700	875	1050	1225	1400	1575	1750
		Tracción / Traction = 1649	148	296	444	592	740	888	1036	1184	1332	1480
Ø63	20	Empuje / Thrust = 3117	280	560	840	1120	1400	1680	1960	2240	2520	2800
		Tracción / Traction = 2803	250	500	750	1000	1250	1500	1750	2000	2250	2500
Ø80	25	Empuje / Thrust = 5027	450	900	1350	1800	2250	2700	3150	3600	4050	4500
		Tracción / Traction = 4536	405	810	1215	1620	2025	2430	2835	3240	3645	4050
Ø100	25	Empuje / Thrust = 7854	700	1400	2100	2800	3500	4200	4900	5650	6360	7000
		Tracción / Traction = 7363	660	1320	1980	2640	3300	3960	4620	5280	5940	6600

CONSUMO CILINDRO - CYLINDER AIR CONSUMPTION

Ø Cilindro Ø Cylinder	Ø Vástago Ø Rod	Superficie útil en mm2 Working Surface in mm2	Presión de trabajo en bar Operating pressure in bar									
			1	2	3	4	5	6	7	8	9	10
			Consumo aire en NL para cada 10mm. de carrera Air consumption in NL for each 10mm. of stroke									
Ø32	12	Empuje / Thrust = 804	0,016	0,024	0,032	0,040	0,048	0,056	0,064	0,072	0,080	0,088
		Tracción / Traction = 691	0,014	0,021	0,028	0,035	0,041	0,048	0,055	0,062	0,069	0,076
Ø40	16	Empuje / Thrust = 1257	0,025	0,038	0,050	0,063	0,075	0,088	0,101	0,113	0,126	0,138
		Tracción / Traction = 1056	0,021	0,032	0,042	0,053	0,063	0,074	0,084	0,095	0,106	0,116
Ø50	20	Empuje / Thrust = 1963	0,039	0,059	0,079	0,098	0,118	0,137	0,157	0,177	0,196	0,216
		Tracción / Traction = 1649	0,033	0,049	0,066	0,082	0,099	0,115	0,132	0,148	0,165	0,181
Ø63	20	Empuje / Thrust = 3117	0,062	0,094	0,125	0,156	0,187	0,218	0,249	0,281	0,312	0,343
		Tracción / Traction = 2803	0,056	0,084	0,112	0,140	0,168	0,196	0,224	0,252	0,280	0,308
Ø80	25	Empuje / Thrust = 5027	0,101	0,151	0,201	0,251	0,302	0,352	0,402	0,452	0,503	0,553
		Tracción / Traction = 4536	0,091	0,136	0,181	0,227	0,272	0,318	0,363	0,408	0,454	0,499
Ø100	25	Empuje / Thrust = 7854	0,157	0,236	0,314	0,393	0,471	0,550	0,628	0,707	0,785	0,864
		Tracción / Traction = 7363	0,147	0,221	0,295	0,368	0,442	0,515	0,589	0,663	0,736	0,810

Tabla de códigos de pedido - Ordering codes

N	H	A	0 3 2	0 0 2 5	G	I S	Variantes / Choices
			Diámetro mm. <i>Diameter mm.</i>	Carrera mm. / Stroke mm.			IS= Vástago inox <i>IS= Stainless steel rod</i>
			32-40-50-63-80-100				Tipo de montaje / Mounting style
			Variantes / Choices				G= Camisa en aluminio perfil Mickey-mouse con ranuras <i>G= Anodized aluminium tube Mickey-mouse profile with slots (32/100)</i>
			A= Antirrotación <i>A= anti-rotation</i>				
			Ejecución / Execution				
			H= Doble efecto amortiguado magnético / Double acting single rod cushioned magnetic				
			L= Doble efecto amortiguado vástago pasante ISO magnético / Double acting double rod ISO cushioned magnetic				
			Q= Doble efecto amortiguado magnético con vástagos gemelos pasante / Double acting double twin rods cushioned magnetic				
SERIE N							

CARRERAS STANDARD mm. - STD STROKES

Ø mm.	25	50	80	100	125	160	200	250	320	350	400	500	600
32	▲●	▲●	▲●	▲●	▲●	▲●	▲●	▲●	▲●	▲●	▲●	▲●	▲●
40	▲●	▲●	▲●	▲●	▲●	▲●	▲●	▲●	▲●	▲●	▲●	▲●	▲●
50	▲●	▲●	▲●	▲●	▲●	▲●	▲●	▲●	▲●	▲●	▲●	▲●	▲●
63	▲●	▲●	▲●	▲●	▲●	▲●	▲●	▲●	▲●	▲●	▲●	▲●	▲●
80	▲●	▲●	▲●	▲●	▲●	▲●	▲●	▲●	▲●	▲●	▲●	▲●	▲●
100	▲●	▲●	▲●	▲●	▲●	▲●	▲●	▲●	▲●	▲●	▲●	▲●	▲●

- ▲ NHA DOBLE EFECTO AMORTIGUADO MAGNÉTICO - DOUBLE ACTING CUSHIONED MAGNETIC
- ▲ NLA DOBLE EFECTO VÁSTAGO PASANTE ISO AMORTIGUADO MAGNÉTICO - DOUBLE ACTING CUSHIONED MAGNETIC WITH DOUBLE ROD END ISO
- NQA DOBLE EFECTO AMORTIGUADO MAGNÉTICO CON VÁSTAGOS PASANTES - DOUBLE ACTING DOUBLE TWIN RODS CUSHIONED MAGNETIC

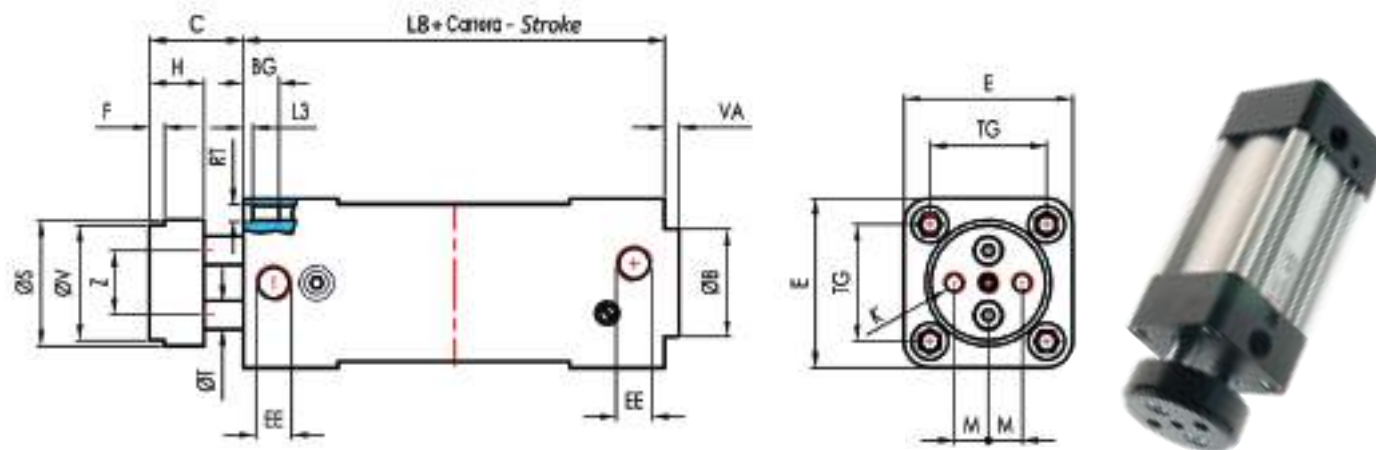

NHA

DOBLE EFECTO AMORTIGUADO MAGNÉTICO - DOUBLE ACTING CUSHIONED MAGNETIC

Ø mm.	ØB d11	C	E	F	H	K	M	S	T	V	Z	F1	VA	L2	WH	ØMM	SW	KK	L8	BG	RT	E	TG	EE	PL	L3	ZM
32	30	26	47	4	15	M6	9.5	35	8	32	18	48	4	20	26	12	10	M10X1.25	94	16	M6	47	32.5	G1/8	14	5	146
40	35	30	53	4	15	M8	11.25	45	10	40	22	54	4	22	30	16	13	M12X1.25	105	16	M6	53	38	G1/4	16	5	165
50	40	37	65	5	18	M8	15	55	12	50	26	69	4	28	37	20	17	M16X1.5	106	16	M8	65	46.5	G1/4	21	5	180
63	45	37	75	5	22	M10	19	70	16	63	35	69	4	28	37	20	17	M16X1.5	121	16	M8	75	56.5	G3/8	22	5	195
80	45	46	95	5	22	M12	25	85	20	80	40	86	4	34	46	25	22	M20X1.5	128	17	M10	95	72	G3/8	23	6.5	220
100	55	51	115	5	22	M12	35	105	20	100	50	91	4	38	51.5	25	22	M20X1.5	138	17	M10	115	89	G1/2	26	6.5	240

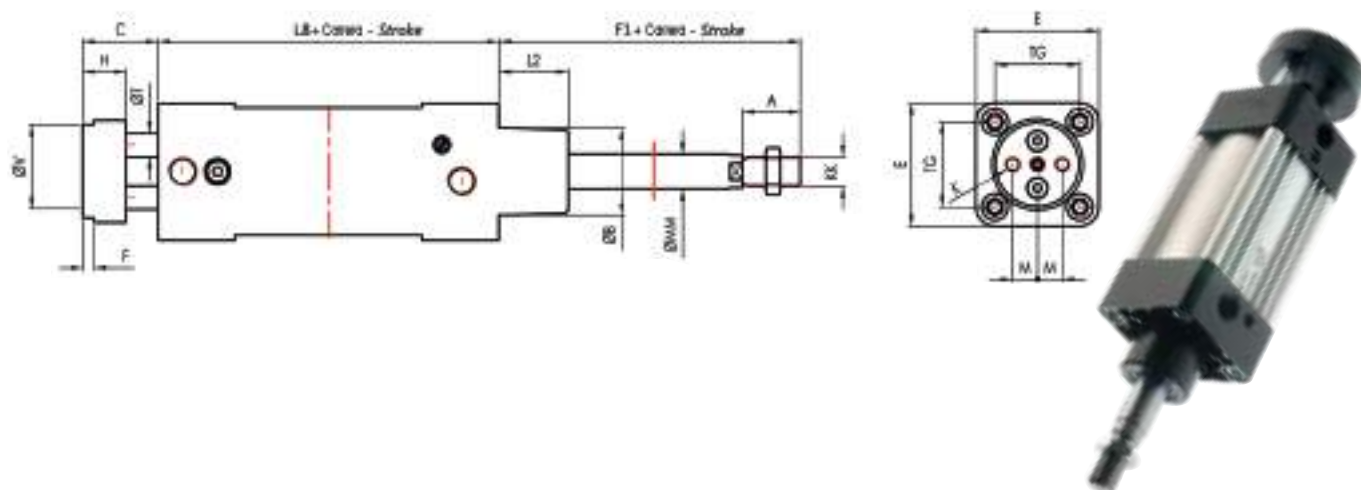

NLA

DOBLE EFECTO VÁSTAGO PASANTE ISO AMORTIGUADO MAGNÉTICO - DOUBLE ACTING CUSHIONED MAGNETIC WITH DOUBLE ROD END ISO

Ø mm.	A	ØB d11	C	E	F	H	K	M	S	T	V	Z	F1	VA	L2	WH	ØMM	SW	KK	L8	BG	RT	E	TG	EE	PL	L3	ZM
32	22	30	26	47	4	15	M6	9.5	35	8	32	18	48	4	20	26	12	10	M10X1.25	94	16	M6	47	32.5	G1/8	14	5	146
40	24	35	30	53	4	15	M8	11.25	45	10	40	22	54	4	22	30	16	13	M12X1.25	105	16	M6	53	38	G1/4	16	5	165
50	32	40	37	65	5	18	M8	15	55	12	50	26	69	4	28	37	20	17	M16X1.5	106	16	M8	65	46.5	G1/4	21	5	180
63	32	45	37	75	5	22	M10	19	70	16	63	35	69	4	28	37	20	17	M16X1.5	121	16	M8	75	56.5	G3/8	22	5	195
80	40	45	46	95	5	22	M12	25	85	20	80	40	86	4	34	46	25	22	M20X1.5	128	17	M10	95	72	G3/8	23	6.5	220
100	40	55	51	115	5	22	M12	35	105	20	100	50	91	4	38	51.5	25	22	M20X1.5	138	17	M10	115	89	G1/2	26	6.5	240

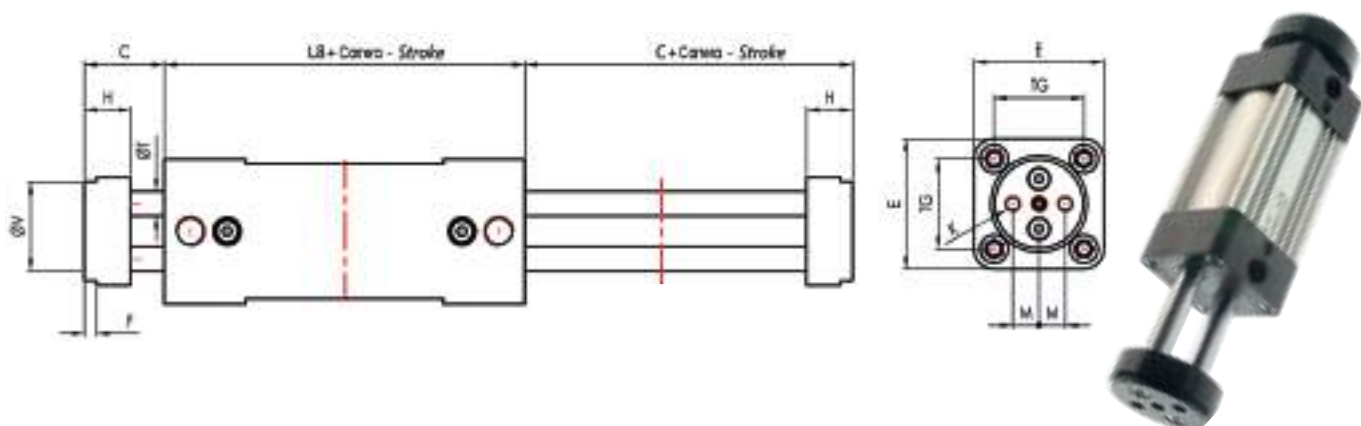

NQA

DOBLE EFECTO AMORTIGUADO MAGNÉTICO CON VÁSTAGOS PASANTES - DOUBLE ACTING DOUBLE TWIN RODS CUSHIONED MAGNETIC

Ø mm.	ØB d11	C	E	F	H	K	M	S	T	V	Z	F1	VA	L2	WH	ØMM	SW	KK	L8	BG	RT	E	TG	EE	PL	L3	ZM
32	30	26	47	4	15	M6	9.5	35	8	32	18	48	4	20	26	12	10	M10X1.25	94	16	M6	47	32.5	G1/8	14	5	146
40	35	30	53	4	15	M8	11.25	45	10	40	22	54	4	22	30	16	13	M12X1.25	105	16	M6	53	38	G1/4	16	5	165
50	40	37	65	5	18	M8	15	55	12	50	26	69	4	28	37	20	17	M16X1.5	106	16	M8	65	46.5	G1/4	21	5	180
63	45	37	75	5	22	M10	19	70	16	63	35	69	4	28	37	20	17	M16X1.5	121	16	M8	75	56.5	G3/8	22	5	195
80	45	46	95	5	22	M12	25	85	20	80	40	86	4	34	46	25	22	M20X1.5	128	17	M10	95	72	G3/8	23	6.5	220
100	55	51	115	5	22	M12	35	105	20	100	50	91	4	38	51.5	25	22	M20X1.5	138	17	M10	115	89	G1/2	26	6.5	240

Gráfico Cilindros NHA / Charts NHA Cylinders

Momento Flexor / Flexion Moment

Momento de Torsión / Torsion Moment

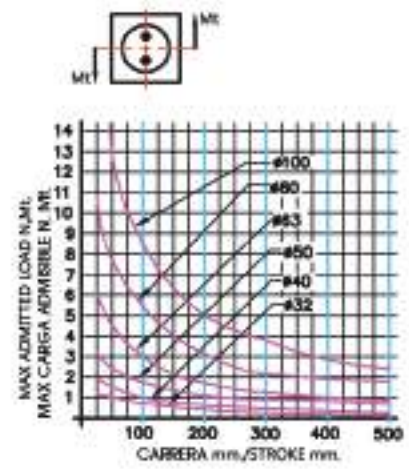
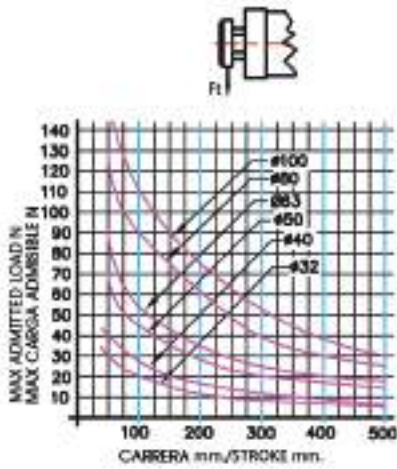

Flexotorsión / Flexion-Torsion

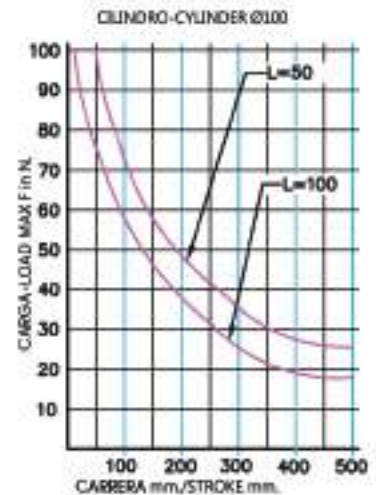
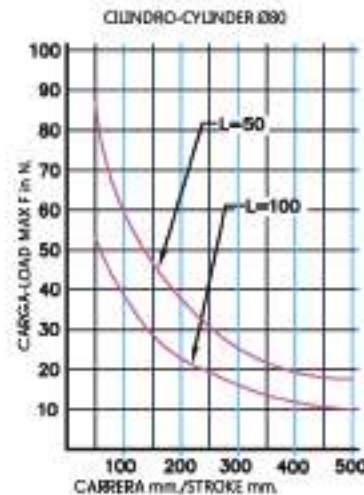
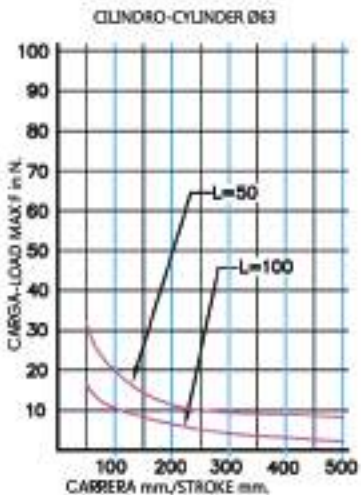
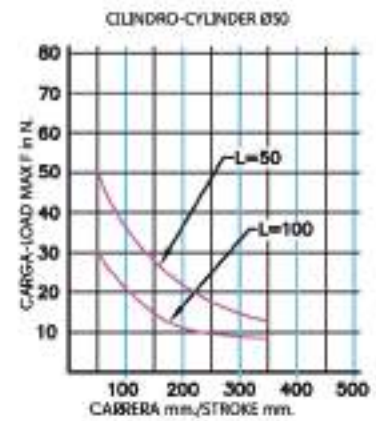
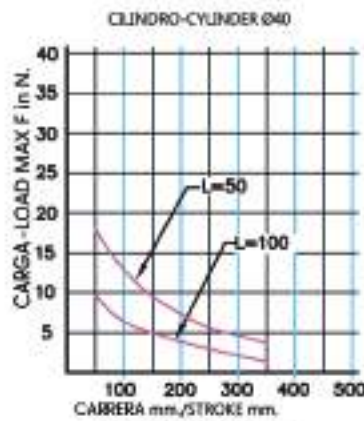
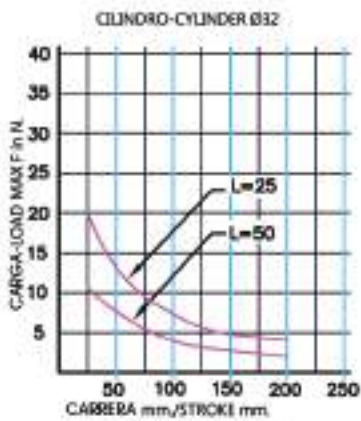
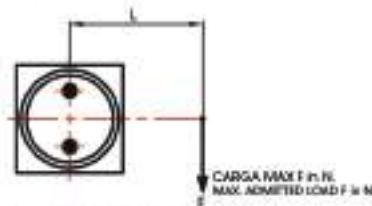

Cilindros Serie P ISO 15552 / Cylinder P Serie ISO 15552

Los cilindros compactos interface ISO 15552 tienen las tapas de aluminio anodizado y una línea muy limpia; los amortiguadores elásticos fijos consienten un rozamiento lineal y silencioso. Los cilindros del Ø32 al Ø100 y el Ø250 tienen todas las juntas en poliuretano. Los cilindros Ø125, 160 y 200 montan un pistón integral en NBR.

Los cilindros de la serie P son suministrados con camisa de aluminio en dos configuraciones:

- Del Ø32 al Ø100 camisa en aluminio a perfil cuadrado denominado TIPO "H" con ranuras longitudinales para la inserción de los sensores magnéticos.

- Del Ø125 al Ø250 Camisa en aluminio de perfil redondo con tirantes.

Compact cylinders to ISO 15552 interfaces have their heads in anodized aluminum and have a very clean line, fixed elastic dampers allow a linear shift and silently. The cylinders from Ø32 to Ø100 and Ø250 have all of the dynamic seals in polyurethane. The cylinders are fitted with a Ø125 160 200 complete piston NBR. The P series cylinders are supplied with aluminum jacket in two configurations:

- From Ø32 to Ø100 shirt aluminum square profile called "H" with longitudinal slots for the insertion in the disappearance of the sensor.

- From Ø125 to Ø250 shirt from aluminum rods with rounded profile.



Del Ø32 al Ø100.

Camisa en aluminio a perfil cuadrado denominado TIPO "H" con ranuras longitudinales para la inserción de los sensores magnéticos.

From Ø32 to Ø100.

Aluminum jacket square profile called "H" with longitudinal slots for the insertion of the retractable sensor.



Del Ø125 al Ø250.

Camisa en aluminio a perfil redondo con tirantes.

From Ø125 to Ø250.

Shirt aluminum rods with rounded profile.

Características Técnicas / Technical Characteristics

Presiones / Pressures

Presión mínima / Minimum pressure: **1 bar** (0.1 MPa)

Presión máxima / Maximum pressure: **10 bar** (1 MPa)

Temperaturas / Temperatures

Temperatura mínima / Minimum temperature: 0 °C
(-20 °C con aire seco / with dry air)

Temperatura máxima / Maximum temperature: +80 °C

Fluidos compatibles / Fluids

Aire comprimido filtrado lubricado y no lubricado
Filtered and lubricated compressed air as well as non lubricated air.

Funcionamiento / Functioning

Doble efecto amortiguado magnético, Simple efecto magnético, Vástago simple o pasante amortiguado magnético.

Double-acting cushioned magnetic, Single-acting magnetic Single or through piston rod magnetic.

Diámetros / Bores

De 32 a 250 mm.

From 32 to 250mm.

Carreras / Strokes

Carreras Standard / Standard Strokes

De 5 a 500 mm / From 5 to 500 mm

Carreras bajo Demanda / Stroke on Demand

Características Técnicas / Technical Characteristics

Materiales empleados para cilindro serie P con camisa en aluminio anodizado cuadrada.

Used Materials for cylinders Serie P with anodized aluminium square profile.

Diámetros / Diameter

32 - 40 - 50 - 63 - 80 - 100

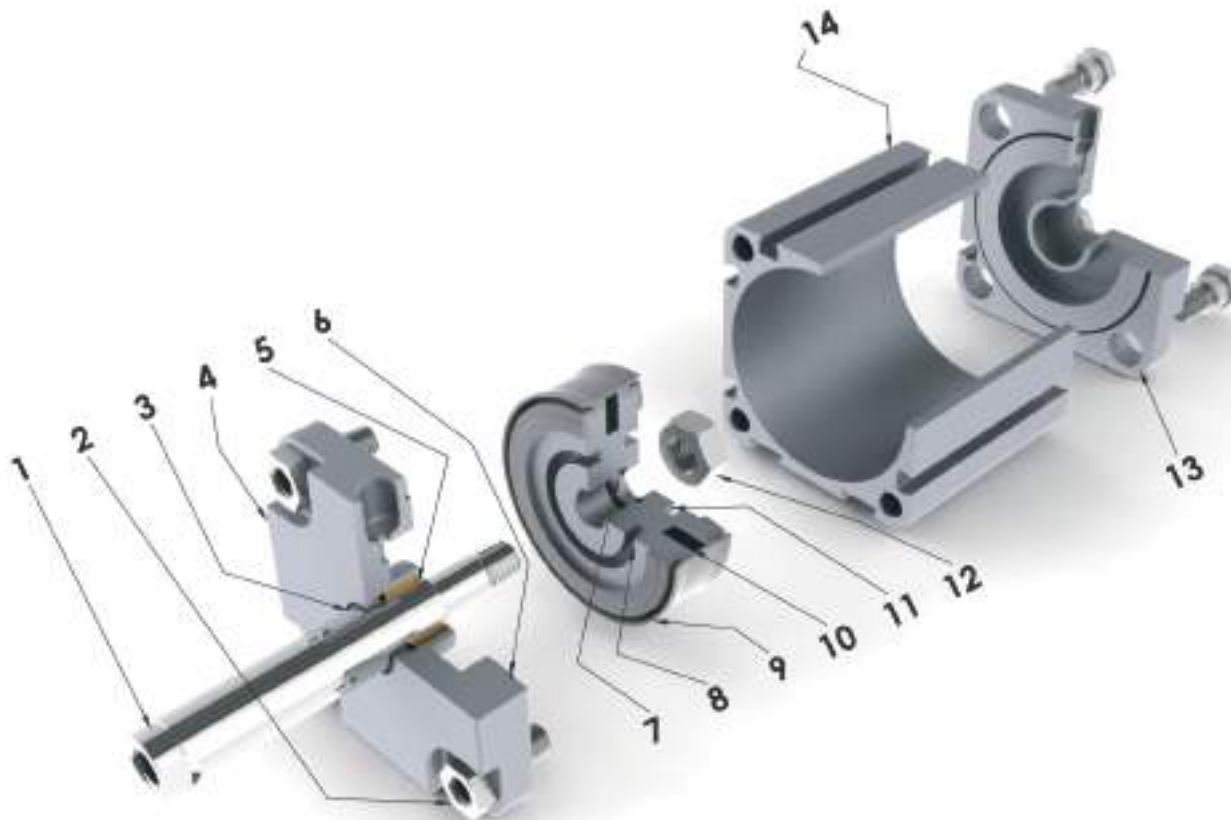

Materiales y Componentes / Component Parts and Materials

- | | |
|---|--|
| 1 Vástago en Acero cromado o Acero inox | 1 Rod Chromium plated steel or Stainless steel |
| 2 Tornillos de fijación en Acero zincado | 2 Fixing screw Galvanized steel |
| 3 Junta vástago en Poliuretano | 3 Rod seal in Polyurethane |
| 4 Tapa anterior en Aluminio Anodizado | 4 Front head In anodized aluminium |
| 5 Cojinete en Bronce sinterizado | 5 Bush in Sintered bronze |
| 6 Junta tórica en Nbr | 6 O-ring in Nbr |
| 7 Junta tórica en Nbr | 7 O-ring in Nbr |
| 8 Pistón Anterior en Aluminio | 8 Front Piston in Aluminium |
| 9 Junta pistón en Poliuretano | 9 Piston seal in Polyurethane |
| 10 Magnete en Plastroferrita | 10 Magnet Bonded ferrite |
| 11 Pistón Posterior en Aluminio | 11 Rear Piston in Aluminium |
| 12 Tuerca en Acero zincado | 12 Nut Galvanized steel |
| 13 Tapa posterior Aluminio Presofundido con chorro de arena | 13 Rear head Die-casted Sandblasted aluminium |
| 14 Camisa en Aluminio anodizado | 14 Tube Anodized aluminium |

Fuerzas y Consumos / Forces And Consumptions

FUERZA DE EMPUJE Y TRACCIÓN - THRUST AND TRACTION FORCES

Ø Cilindro Ø Cylinder	Ø Vástago Ø Rod	Superficie útil en mm ² Working Surface in mm ²	Presión de trabajo en bar Operating pressure in bar									
			1	2	3	4	5	6	7	8	9	10
			Fuerza desarrollada en N Output force in N									
Ø32	12	Empuje / Thrust = 804	72	144	216	288	360	432	504	576	648	720
		Tracción / Traction = 691	62	124	186	248	310	372	434	496	558	620
Ø40	16	Empuje / Thrust = 1257	110	220	330	440	550	660	770	880	990	1100
		Tracción / Traction = 1056	95	190	285	380	475	570	665	760	855	950
Ø50	20	Empuje / Thrust = 1963	175	350	525	700	875	1050	1225	1400	1575	1750
		Tracción / Traction = 1649	148	296	444	592	740	888	1036	1184	1332	1480
Ø63	20	Empuje / Thrust = 3117	280	560	840	1120	1400	1680	1960	2240	2520	2800
		Tracción / Traction = 2803	250	500	750	1000	1250	1500	1750	2000	2250	2500
Ø80	25	Empuje / Thrust = 5027	450	900	1350	1800	2250	2700	3150	3600	4050	4500
		Tracción / Traction = 4536	405	810	1215	1620	2025	2430	2835	3240	3645	4050
Ø100	25	Empuje / Thrust = 7854	700	1400	2100	2800	3500	4200	4900	5650	6360	7000
		Tracción / Traction = 7363	660	1320	1980	2640	3300	3960	4620	5280	5940	6600

CONSUMO CILINDRO - CYLINDER AIR CONSUMPTION

Ø Cilindro Ø Cylinder	Ø Vástago Ø Rod	Superficie útil en mm ² Working Surface in mm ²	Presión de trabajo en bar Operating pressure in bar									
			1	2	3	4	5	6	7	8	9	10
			Consumo aire en NL para cada 10mm. de carrera Air consumption in NL for each 10mm. of stroke									
Ø32	12	Empuje / Thrust = 804	0,016	0,024	0,032	0,040	0,048	0,056	0,064	0,072	0,080	0,088
		Tracción / Traction = 691	0,014	0,021	0,028	0,035	0,041	0,048	0,055	0,062	0,069	0,076
Ø40	16	Empuje / Thrust = 1257	0,025	0,038	0,050	0,063	0,075	0,088	0,101	0,113	0,126	0,138
		Tracción / Traction = 1056	0,021	0,032	0,042	0,053	0,063	0,074	0,084	0,095	0,106	0,116
Ø50	20	Empuje / Thrust = 1963	0,039	0,059	0,079	0,098	0,118	0,137	0,157	0,177	0,196	0,216
		Tracción / Traction = 1649	0,033	0,049	0,066	0,082	0,099	0,115	0,132	0,148	0,165	0,181
Ø63	20	Empuje / Thrust = 3117	0,062	0,094	0,125	0,156	0,187	0,218	0,249	0,281	0,312	0,343
		Tracción / Traction = 2803	0,056	0,084	0,112	0,140	0,168	0,196	0,224	0,252	0,280	0,308
Ø80	25	Empuje / Thrust = 5027	0,101	0,151	0,201	0,251	0,302	0,352	0,402	0,452	0,503	0,553
		Tracción / Traction = 4536	0,091	0,136	0,181	0,227	0,272	0,318	0,363	0,408	0,454	0,499
Ø100	25	Empuje / Thrust = 7854	0,157	0,236	0,314	0,393	0,471	0,550	0,628	0,707	0,785	0,864
		Tracción / Traction = 7363	0,147	0,221	0,295	0,368	0,442	0,515	0,589	0,663	0,736	0,810

FUERZA DEL MUELLE - SPRING TRACTION FORCES

Ø Cilindro Ø Cylinder	Carga Muelle Load Spring	Carrera / Stroke				
		25	50	75	80	100
		Fuerza desarrollada en N Output force in N				
Ø32	Carga Muelle en Reposo / Load of spring at rest	50	41	33	31,5	24,5
	Carga Muelle Comprimido / Load of compressed spring	58	58	58	58	58
Ø40	Carga Muelle en Reposo / Load of spring at rest	52	43	34	32	25
	Carga Muelle Comprimido / Load of compressed spring	61	61	61	61	61
Ø50	Carga Muelle en Reposo / Load of spring at rest	92	77	64	60	49
	Carga Muelle Comprimido / Load of compressed spring	110	110	110	110	110
Ø63	Carga Muelle en Reposo / Load of spring at rest	92	77	64	60	49
	Carga Muelle Comprimido / Load of compressed spring	110	110	110	110	110
Ø80	Carga Muelle en Reposo / Load of spring at rest	117	98	79	75	59
	Carga Muelle Comprimido / Load of compressed spring	138	138	138	138	138
Ø100	Carga Muelle en Reposo / Load of spring at rest	117	98	79	75	59
	Carga Muelle Comprimido / Load of compressed spring	138	138	138	138	138

Tabla de códigos de pedido - Ordering codes

P	F	M	0 3 2	0 0 2 5	H	I S	<p>Variantes / Choices</p> <p>IS= Vástago inox IS= Stainless steel rod</p> <p>Tipo de montaje / Mounting style</p> <p>H= Camisa en aluminio perfil cuadrado H= Anodized aluminium tube square profile (32/100)</p>
<p>Carrera mm. / Stroke mm.</p> <p>5 - 10 - 15 - 20 - 25 - 30 - 35 - 40 - 45 - 50 - 55 - 60 - 65 - 70 - 75-80-100 -125 -150 -160 - 200 - 250 - 300 - 320 - 350 - 400 - 450 - 500</p> <p>Bajo demanda carreras intermedias o superiores Intermediate or higher strokes are available upon request.</p>							
<p>Diámetro mm. / Diameter mm.</p> <p>32-40-50-63-80-100</p>							
<p>Versiones / Version</p> <p>= Standard Vástago hembra / Standard female rod M= Vástago Macho / Male rod</p>							
<p>Ejecución / Execution</p> <p>B= Simple efecto muelle anterior magnético (carrera max. 25) / Single acting front spring magnetic (corsa max. 25) D= Simple efecto muelle posterior magnético (carrera max. 25) / Single acting rear spring magnetic (corsa max. 25) F= Doble efecto magnético / Double acting single rod magnetic J= Doble efecto vástago pasante magnético / Double acting double rod magnetic</p>							
<p>SERIE P</p>							

CARRERAS STANDARD mm. - STD STROKES

∅ mm.	5	10	15	20	25	30	35	40	45	50	55	60	65	70	75	80	100	125	150	160	200	250	300	320	350	400	450	500
32	▲	▲	▲	▲	▲	●	●	●	●	●	●	●	●	●	●	●	●	●	●	●	●	●	●	●	●	●	●	●
40	▲	▲	▲	▲	▲	●	●	●	●	●	●	●	●	●	●	●	●	●	●	●	●	●	●	●	●	●	●	●
50	▲	▲	▲	▲	▲	●	●	●	●	●	●	●	●	●	●	●	●	●	●	●	●	●	●	●	●	●	●	●
63	▲	▲	▲	▲	▲	●	●	●	●	●	●	●	●	●	●	●	●	●	●	●	●	●	●	●	●	●	●	●
80	▲	▲	▲	▲	▲	●	●	●	●	●	●	●	●	●	●	●	●	●	●	●	●	●	●	●	●	●	●	●
100	▲	▲	▲	▲	▲	●	●	●	●	●	●	●	●	●	●	●	●	●	●	●	●	●	●	●	●	●	●	●

- ▲ **PB SIMPLE EFECTO MAGNÉTICO MUELLE ANTERIOR** - SINGLE-ACTING FRONT SPRING MAGNETIC
- ▲ **PD SIMPLE EFECTO MAGNÉTICO MUELLE POSTERIOR** - SINGLE-ACTING REAR SPRING MAGNETIC
- **PF DOBLE EFECTO MAGNÉTICO** - DOUBLE ACTING MAGNETIC
- **PJ DOBLE EFECTO VÁSTAGO PASANTE MAGNÉTICO** - DOUBLE ACTING MAGNETIC WITH DOUBLE ROD END

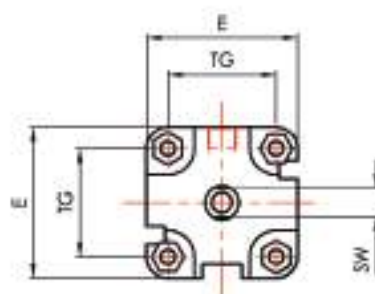
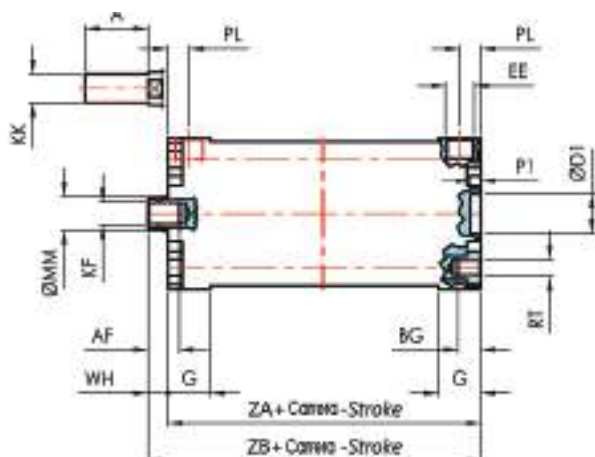

PB-----H

Camisa en aluminio a perfil cuadrado.
Anodized aluminium tube square profile.

SIMPLE EFECTO MAGNÉTICO MUELLE ANTERIOR - SINGLE-ACTING FRONT SPRING MAGNETIC

Ø mm.	A	E	G	TG	AF	BG	D1	EE	KF	KK	MM	P1	PL	RT	SW	WH	ZA	ZB
32	22	47	14.7	32.5	12	9	14	1/8"G	M8	M10X1.25	12	2.5	7.5	M6	10	7	44	51
40	22	53	15	38	12	9	14	1/8"G	M8	M10X1.25	12	2.5	7.5	M6	10	7	45	52
50	24	65	15	46.5	16	9	18	1/8"G	M10	M12X1.25	16	2.5	7.5	M8	13	8	45	53
63	24	75	14.5	56.5	16	9	18	1/8"G	M10	M12X1.25	16	2.5	7	M8	13	8	49	57
80	32	95	15.5	72	20	9	23	1/8"G	M12	M16X1.5	20	3	8.5	M10	16	10	54	64
100	40	115	20	89	20	9	28	1/4"G	M12	M20X1.5	25	3	9.5	M10	22	10	67	77

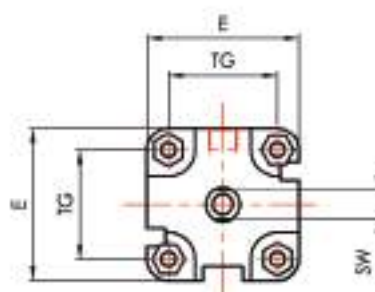
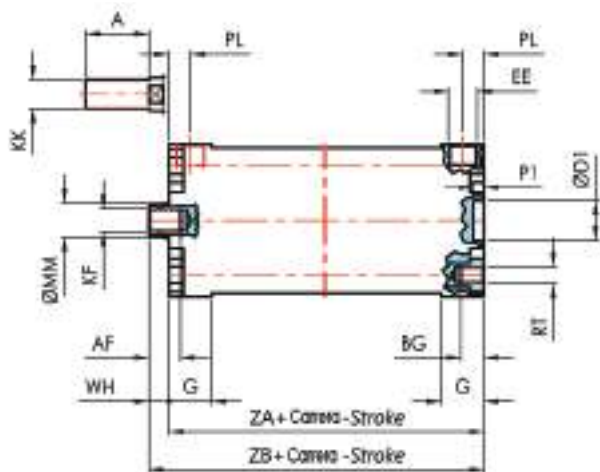

PD-----H

Camisa en aluminio a perfil cuadrado.
Anodized aluminium tube square profile.

SIMPLE EFECTO MAGNÉTICO MUELLE POSTERIOR - SINGLE-ACTING REAR SPRING MAGNETIC

Ø mm.	A	E	G	TG	AF	BG	D1	EE	KF	KK	MM	P1	PL	RT	SW	WH	ZA	ZB
32	22	47	14.7	32.5	12	9	14	1/8"G	M8	M10X1.25	12	2.5	7.5	M6	10	7	44	51
40	22	53	15	38	12	9	14	1/8"G	M8	M10X1.25	12	2.5	7.5	M6	10	7	45	52
50	24	65	15	46.5	16	9	18	1/8"G	M10	M12X1.25	16	2.5	7.5	M8	13	8	45	53
63	24	75	14.5	56.5	16	9	18	1/8"G	M10	M12X1.25	16	2.5	7	M8	13	8	49	57
80	32	95	15.5	72	20	9	23	1/8"G	M12	M16X1.5	20	3	8.5	M10	16	10	54	64
100	40	115	20	89	20	9	28	1/4"G	M12	M20X1.5	25	3	9.5	M10	22	10	67	77

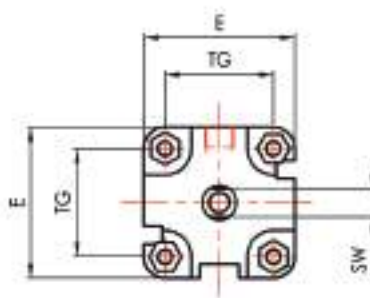
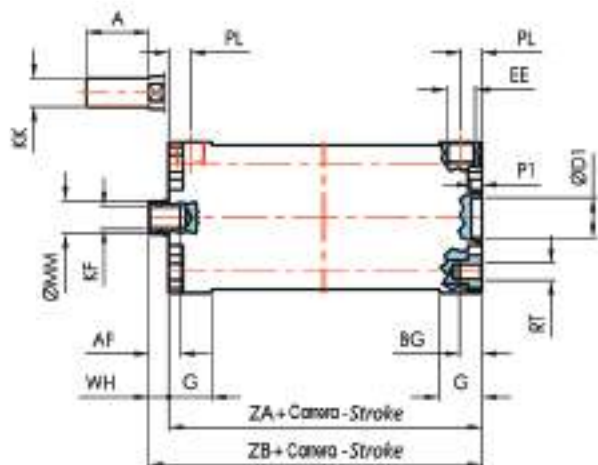

PF-----H

Camisa en aluminio a perfil cuadrado.
Anodized aluminium tube square profile.

DOBLE EFECTO MAGNÉTICO - DOUBLE ACTING MAGNETIC

Ø mm.	A	E	G	TG	AF	BG	D1	EE	KF	KK	MM	P1	PL	RT	SW	WH	ZA	ZB
32	22	47	14.7	32.5	12	9	14	1/8"G	M8	M10X1.25	12	2.5	7.5	M6	10	7	44	51
40	22	53	15	38	12	9	14	1/8"G	M8	M10X1.25	12	2.5	7.5	M6	10	7	45	52
50	24	65	15	46.5	16	9	18	1/8"G	M10	M12X1.25	16	2.5	7.5	M8	13	8	45	53
63	24	75	14.5	56.5	16	9	18	1/8"G	M10	M12X1.25	16	2.5	7	M8	13	8	49	57
80	32	95	15.5	72	20	9	23	1/8"G	M12	M16X1.5	20	3	8.5	M10	16	10	54	64
100	40	115	20	89	20	9	28	1/4"G	M12	M20X1.5	25	3	9.5	M10	22	10	67	77

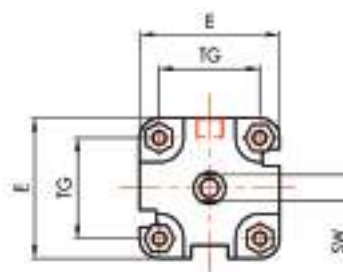
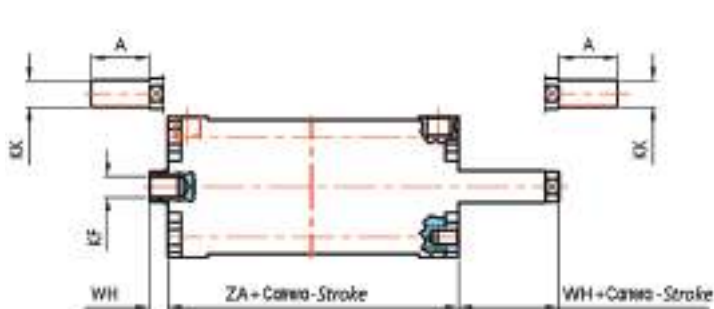

PJ-----H

Camisa en aluminio a perfil cuadrado.
Anodized aluminium tube square profile.

DOBLE EFECTO VÁSTAGO PASANTE MAGNÉTICO - DOUBLE ACTING MAGNETIC WITH DOUBLE ROD END

Ø mm.	A	E	G	TG	AF	BG	D1	EE	KF	KK	MM	P1	PL	RT	SW	WH	ZA	ZB
32	22	47	14.7	32.5	12	9	14	1/8"G	M8	M10X1.25	12	2.5	7.5	M6	10	7	44	51
40	22	53	15	38	12	9	14	1/8"G	M8	M10X1.25	12	2.5	7.5	M6	10	7	45	52
50	24	65	15	46.5	16	9	18	1/8"G	M10	M12X1.25	16	2.5	7.5	M8	13	8	45	53
63	24	75	14.5	56.5	16	9	18	1/8"G	M10	M12X1.25	16	2.5	7	M8	13	8	49	57
80	32	95	15.5	72	20	9	23	1/8"G	M12	M16X1.5	20	3	8.5	M10	16	10	54	64
100	40	115	20	89	20	9	28	1/4"G	M12	M20X1.5	25	3	9.5	M10	22	10	67	77

Características Técnicas / Technical Characteristics

Materiales empleados para cilindro serie P con camisa en aluminio anodizado a perfil redondo con tirantes
Used Materials for cylinders Serie P with anodized aluminium tube profile and tie rods.

Diámetros / Diameter

125 - 160 - 200 - 250

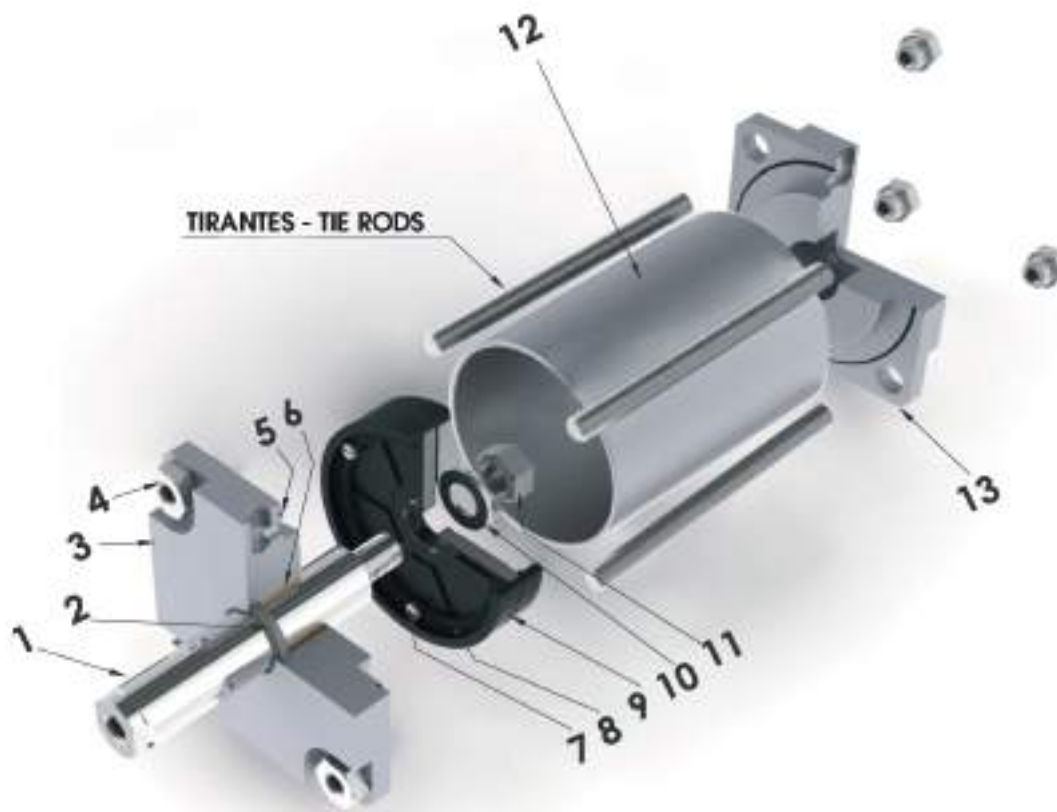

Materiales y Componentes / Component Parts and Materials

1 Vástago en Acero cromado o Acero inox	1 Rod Chromium plated steel or Stainless steel
2 Junta vástago en Poliuretano	2 Rod seal in Polyurethane
3 Tapa anterior en Aluminio Anodizado	3 Front head In anodized aluminium
4 Tornillos de fijación en Acero zincado	4 Fixing screw Galvanized steel
5 Junta tórica en Nbr	5 O-ring in Nbr
6 Cojinete en Bronce sinterizado	6 Bush in Sintered bronze
7 Tornillos de fijación en Acero zincado	7 Fixing screw Galvanized steel
8 Magnete en Plastroferrita	8 Magnet Bonded ferrite
9 Pistón NBR-(Ø250 Pistón en Aluminio e poliuretano)	9 NBR Piston (Ø250 ALuminium and poliurethane)
10 Arandela en acero zincado	10 Washer Galvanized steel
11 Tuerca en Acero zincado	11 Nut Galvanized steel
12 Camisa en Aluminio anodizado	12 Tube Anodized aluminium
13 Tapa posterior en Aluminio Anodizado	13 Rear head In anodized aluminium

Fuerzas y Consumos / Forces And Consumptions

FUERZA DE EMPUJE Y TRACCIÓN - THRUST AND TRACTION FORCES

Ø Cilindro Ø Cylinder	Ø Vástago Ø Rod	Superficie útil en mm ² Working Surface in mm ²	Presión de trabajo en bar Operating pressure in bar									
			1	2	3	4	5	6	7	8	9	10
			Fuerza desarrollada en N Output force in N									
Ø125	32	Empuje / Thrust = 12270	1104	2208	3312	4416	5520	6624	7728	8832	9936	11040
		Tracción / Traction = 11468	1032	2064	3096	4128	5160	6192	7224	8256	9288	10320
Ø160	40	Empuje / Thrust = 20096	1774	3548	5322	7097	8871	10645	12419	14194	15968	17742
		Tracción / Traction = 18840	1663	3326	4990	6653	8316	9980	11643	13307	14970	16633
Ø200	40	Empuje / Thrust = 31440	2772	5544	8316	11089	13861	16633	19406	22178	24950	27723
		Tracción / Traction = 30144	2661	5322	7984	10645	13307	15968	18629	21291	23952	26614
Ø250	50	Empuje / Thrust = 48750	4331	8663	12995	17326	21658	25990	30322	34653	38985	43317
		Tracción / Traction = 46800	4158	8316	12475	16663	20792	24950	29109	33267	37426	41584

CONSUMO CILINDRO - CYLINDER AIR CONSUMPTION

Ø Cilindro Ø Cylinder	Ø Vástago Ø Rod	Superficie útil en mm ² Working Surface in mm ²	Presión de trabajo en bar Operating pressure in bar									
			1	2	3	4	5	6	7	8	9	10
			Consumo aire en NL para cada 10mm. de carrera Air consumption in NL for each 10mm. of stroke									
Ø125	32	Empuje / Thrust = 12270	0,245	0,368	0,491	0,614	0,736	0,859	0,982	1,104	1,227	1,350
		Tracción / Traction = 11468	0,229	0,344	0,459	0,573	0,688	0,803	0,917	1,032	1,147	1,261
Ø160	40	Empuje / Thrust = 20096	0,402	0,603	0,804	1,005	1,206	1,407	1,608	1,809	2,010	2,211
		Tracción / Traction = 18840	0,377	0,565	0,754	0,942	1,130	1,319	1,507	1,696	1,884	2,072
Ø200	40	Empuje / Thrust = 31440	0,628	0,942	1,256	1,570	1,884	2,198	2,512	2,826	3,140	3,454
		Tracción / Traction = 30144	0,603	0,904	1,206	1,507	1,809	2,110	2,412	2,713	3,014	3,316
Ø250	50	Empuje / Thrust = 48750	0,981	1,472	1,963	2,453	2,948	3,434	3,925	4,415	4,906	5,400
		Tracción / Traction = 46800	0,942	1,413	1,884	2,355	2,826	3,297	3,768	4,239	4,710	5,181

Tabla de códigos de pedido - Ordering codes

P	F	M	0 3 2	0 0 2 5	H	I S
<p>Variantes / Choices</p> <p>IS= Vástago inox IS= Stainless steel rod</p> <p>Tipo de montaje / Mounting style</p> <p>T= Camisa aluminio perfil redondo con tirantes T= Anodized aluminium tube round profile with tie rods (125/250) mm.</p> <p>Carrera mm. / Stroke mm.</p> <p>5 - 10 - 15 - 20 - 25 - 30 - 35 - 40 - 45 - 50 - 55 - 60 - 65 - 70 - 75-80-100 -125 -150 -160 - 200 - 250 - 300 - 320 - 350 - 400 - 450 - 500</p> <p>Bajo demanda carreras intermedias o superiores <i>Intermediate or higher strokes are available upon request.</i></p> <p>Diámetro mm. / Diameter mm.</p> <p>32-40-50-63-80-100-125-160-200-250</p> <p>Versiónes / Version</p> <p>= Standard Vástago hembra / Standard female rod M= Vástago Macho / Male rod</p> <p>Ejecución / Execution</p> <p>F= Doble efecto magnético / Double acting single rod magnetic J= Doble efecto vástago pasante magnético / Double acting double rod magnetic</p>						

SERIE P

CARRERAS STANDARD mm. - STD STROKES

Ø mm.	25	50	75	80	100	125	150	160	200	250	300	320	350	400	450	500	600	700	800	900	1000	
125	▲	▲	▲	▲	▲	▲	▲	▲	▲	▲	▲	▲	▲	▲	▲	▲	▲	▲	▲	▲	▲	▲
160	▲	▲	▲	▲	▲	▲	▲	▲	▲	▲	▲	▲	▲	▲	▲	▲	▲	▲	▲	▲	▲	▲
200	▲	▲	▲	▲	▲	▲	▲	▲	▲	▲	▲	▲	▲	▲	▲	▲	▲	▲	▲	▲	▲	▲
250	▲	▲	▲	▲	▲	▲	▲	▲	▲	▲	▲	▲	▲	▲	▲	▲	▲	▲	▲	▲	▲	▲

▲ PF DOBLE EFECTO MAGNÉTICO - DOUBLE ACTING MAGNETIC

▲ PJ DOBLE EFECTO VÁSTAGO PASANTE MAGNÉTICO - DOUBLE ACTING MAGNETIC WITH DOUBLE ROD END

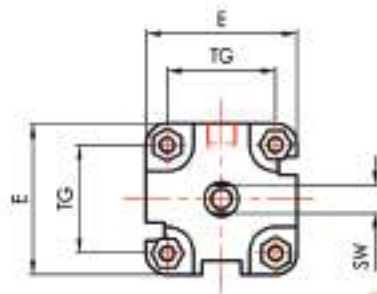
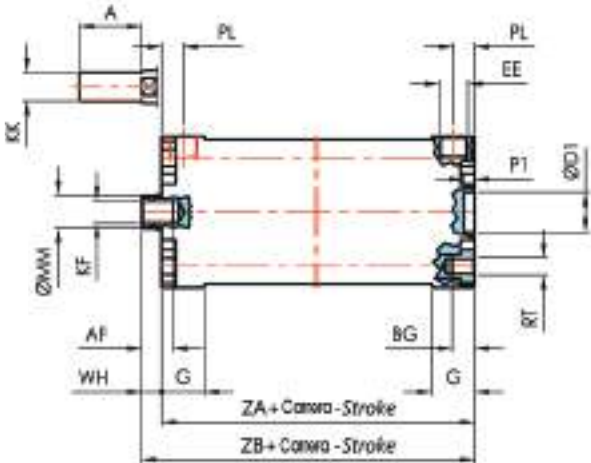

PF-----T

Camisa en aluminio a perfil redondo.
Anodized aluminium tube round profile with tie rods.

DOBLE EFECTO MAGNÉTICO - DOUBLE ACTING MAGNETIC

Ø mm.	A	E	G	TG	AF	BG	D1	EE	KF	KK	MM	P1	PL	RT	SW	WH	ZA	ZB
125	54	140	22.5	110	25	12	-	1/4"G	M14	M27X2	32	-	10	M12	27	10	78	88
160	72	180	26.5	140	30	13	-	3/8"G	M20	M36X2	40	-	12	M16	36	12	87	99
200	72	220	26.5	175	30	13	-	3/8"G	M20	M36X2	40	-	12	M16	36	12	87	99
250	84	270	35	220	30	16	-	1/2"G	M24X2	M42X2	50	-	16	M20	46	15	125	140

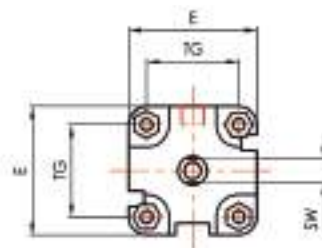
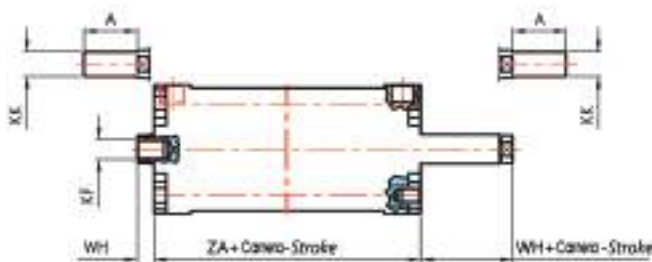

PJ-----T

Camisa en aluminio a perfil redondo.
Anodized aluminium tube round profile with tie rods.

DOBLE EFECTO VÁSTAGO PASANTE MAGNÉTICO - DOUBLE ACTING MAGNETIC WITH DOUBLE ROD END

Ø mm.	A	E	G	TG	AF	BG	D1	EE	KF	KK	MM	P1	PL	RT	SW	WH	ZA	ZB
125	54	140	22.5	110	25	12	-	1/4"G	M14	M27X2	32	-	10	M12	27	10	78	88
160	72	180	26.5	140	30	13	-	3/8"G	M20	M36X2	40	-	12	M16	36	12	87	99
200	72	220	26.5	175	30	13	-	3/8"G	M20	M36X2	40	-	12	M16	36	12	87	99
250	84	270	35	220	30	16	-	1/2"G	M24X2	M42X2	50	-	16	M20	46	15	125	140

Componentes de fijación para cilindros ISO6431 e ISO15552

Mounting Accessories for cylinders ISO6431 and ISO 15552

MATERIAL: ALUMINIO
MATERIAL: ALUMINIUM

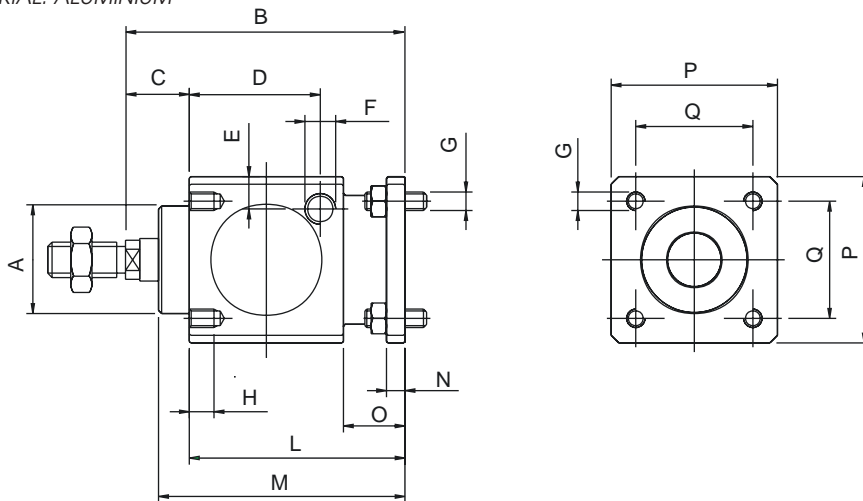

VRL

UNIDAD DE BLOQUEO - PISTON ROD LOCK

Ø mm.	A	B	C	D	E	F	G	H	L	M	N	O	P	Q
32	30	86	26	33.25	9	1/8"G	M6	8	60	67.5	6	20	47	32.5
40	34.5	100	30	42.5	9	1/8"G	M6	8	70	80	6	20	54	38
50	40	127	37	58	12.5	1/8"G	M8	12	90	100	8	24	65	46.5
63	45	127	37	59	17.5	1/8"G	M8	12	90	100	8	24	75	56.5
80	45	156	46	69	17.5	1/4"G	M10	16	110	120	12	32	95	72
100	55	161	51	69	20	1/4"G	M10	16	110	120	12	32	114	89
125	60	205	65	84.5	19	1/4"G	M12	20	140	156	20	45	138	110

MATERIAL: ALUMINIO
MATERIAL: ALUMINIUM

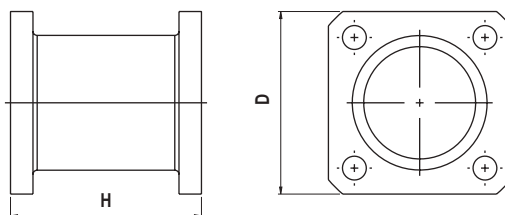

VFT

BRIDA PARA CILINDRO CONTRAPUESTO - JOINING FLANGE

Código / Code	Ø mm.	H	D
VFT032	32	55	45
VFT040	40	55	52
VFT050	50	68	65
VFT063	63	68	75
VFT080	80	92	95
VFT100	100	92	115
VFT125	125	120	140

MATERIAL: ACERO
MATERIAL: STEEL

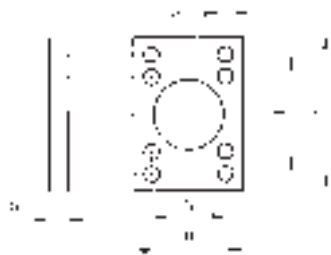

VFL

BRIDA - FLANGE

Código / Code	Ø mm.	P	Q	S	R	T	V
VFL032	32	7	32	10	45	64	80
VFL040	40	9	36	10	52	72	90
VFL050	50	9	45	12	65	90	110
VFL063	63	9	50	12	75	100	120
VFL080	80	12	63	16	95	126	150
VFL100	100	14	75	16	115	150	170
VFL125	125	16	90	20	140	180	205
VFL160	160	18	115	20	180	230	260
VFL200	200	22	135	25	220	270	300
VFL250	250	26	165	25	285	330	400
VFL320	320	33	200	30	350	400	470

MATERIAL: ACERO
MATERIAL: STEEL

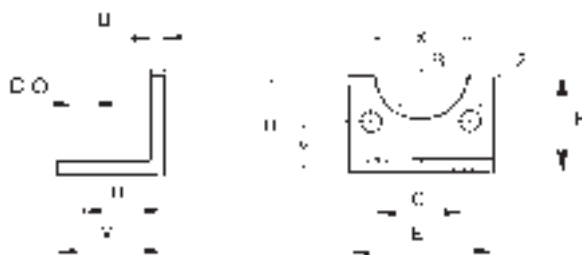

VCP

PATA - LOW - RISE PEDESTAL

Código / Code	Ø mm.	B	C	E	F	O	U	V	R	Z	X	Y	H
VCP032	32	4	32	45	30	7	24	35	15	7	32.5	15.75	32
VCP040	40	4	36	52	30	10	28	36	17.5	7	38	17	36
VCP050	50	5	45	65	36	10	32	47	20	9	46.5	21.75	45
VCP063	63	5	50	75	35	10	32	45	22.5	9	56.5	21.75	50
VCP080	80	6	63	95	47	12	41	55	22.5	11	72	27	63
VCP100	100	6	75	115	53	14.5	41	57	27.5	11	89	26.5	71
VCP125	125	8	90	140	70	16.5	45	70	30	14	110	35	90
VCP160	160	9	115	180	115	18	60	75	32.5	18	140	45	115
VCP200	200	12	135	220	135	21	70	100	37.5	18	175	47.5	135
VCP250	250	14	165	270	165	26	75	100	45	22	220	55	165

MATERIAL: ACERO
MATERIAL: STEEL

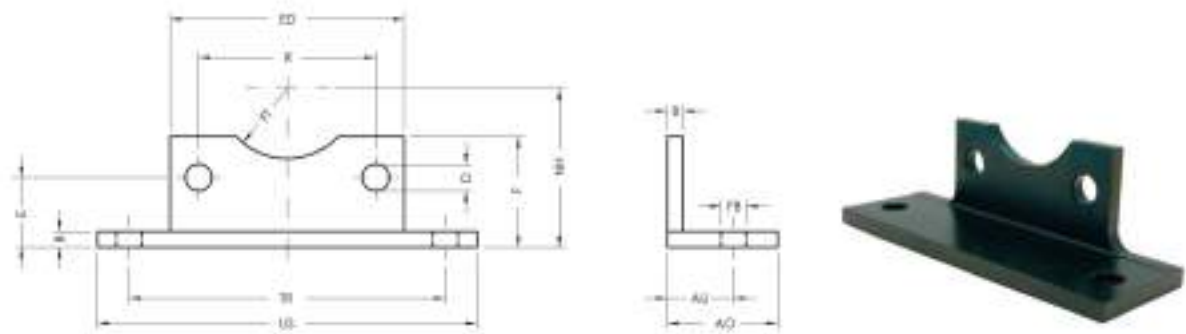

VCB

PATA - LARGE LOW - RISE PEDESTAL

Código / Code	Ø mm.	US	ED	F	AO	B	TR	E	D	FT	NH	R	AU	FB
VCB032	32	79	45	30	30	5	65	15.75	6.5	15	32	32.5	18	6.5
VCB040	40	90	55	30	30	5	75	17	6.5	17.5	36	38	18	6.5
VCB050	50	110	65	35	35	5	90	21.75	8.5	22.5	50	56.5	21	8.5
VCB063	63	120	75	35	35	5	100	21.75	8.5	22.5	50	56.5	21	8.5
VCB080	80	153	95	45	45	6	128	26.5	10.5	22.5	63	72	27	10.5
VCB100	100	178	115	45	45	6	148	27	10.5	27.5	71	89	27	10.5

MATERIAL: ALUMINIO
MATERIAL: ALUMINIUM

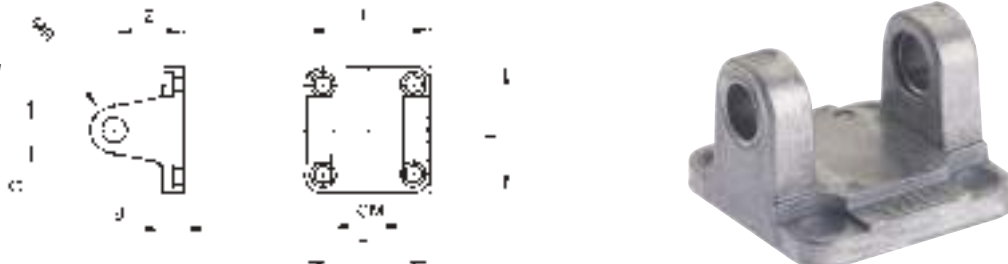

VCF

CHARNELA HEMBRA CON COJINETES AUTOLUBRICANTES - FEMALE CLEVIS BRACKET SELF-LUBRICATING

Código / Code	Ø mm.	B	E	G	T	Z	CM	MR
VCF032	32	9	45	10	45	22	26	10
VCF040	40	9	52	12	52	25	28	12
VCF050	50	11	65	12	60	27	32	12
VCF063	63	11	75	16	70	32	40	16
VCF080	80	14	95	16	90	36	50	16
VCF100	100	14	115	20	110	41	60	20
VCF125	125	20	140	25	130	50	70	25
VCF160	160	20	180	30	170	55	90	25
VCF200	200	25	220	30	170	60	90	25

MATERIAL: ALUMINIO
MATERIAL: ALUMINIUM

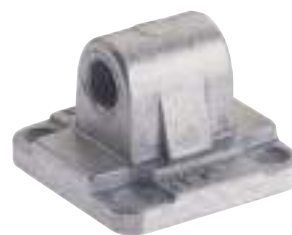
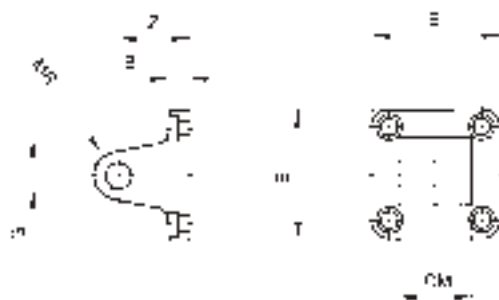

VCM

CHARNELA MACHO - MALE CLEVIS BRACKET

Código / Code	Ø mm.	B	E	G	Z	CM	MR
VCM032	32	9	45	10	22	26	10
VCM040	40	9	52	12	25	28	12
VCM050	50	11	65	12	27	32	12
VCM063	63	11	75	16	32	40	16
VCM080	80	14	95	16	36	50	16
VCM100	100	14	115	20	41	60	20
VCM125	125	20	140	25	50	70	25
VCM160	160	20	180	30	55	90	25
VCM200	200	25	220	30	60	90	25
VCM250	250	25	270	40	70	110	40

MATERIAL: ALUMINIO
MATERIAL: ALUMINIUM

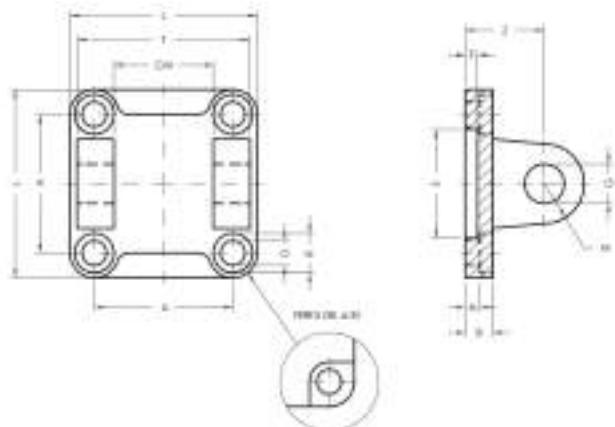

VCH

CHARNELA HEMBRA - FEMALE CLEVIS BRACKET

Código / Code	Ø mm.	A	L	D	R	N	B	S	F	Z	G	M	CM	T
VCH032	32	32.5	45	6.6	11	5.5	9	30	5	22	10	10	26	45
VCH040	40	38	52	6.6	11	5.5	9	35	5	25	12	12	28	52
VCH050	50	46.5	65	9	15	6.5	11	40	5	27	12	12	32	60
VCH063	63	56.5	75	9	15	6.5	11	45	5	32	16	16	40	70
VCH080	80	72	95	11	18	10	14	45	5	36	16	16	50	90
VCH100	100	89	115	11	18	10	14	55	5	41	20	20	60	110
VCH125	125	110	140	14	20	10	20	60	7	50	25	25	70	130
VCH160	160	140	180	18	26	10	20	65	7	55	30	25	90	170
VCH200	200	175	220	18	26	11	25	75	7	60	30	25	90	170
VCH250	250	220	270	22	33	11	25	90	-	70	40	40	110	200

MATERIAL: ALUMINIO
MATERIAL: ALUMINIUM

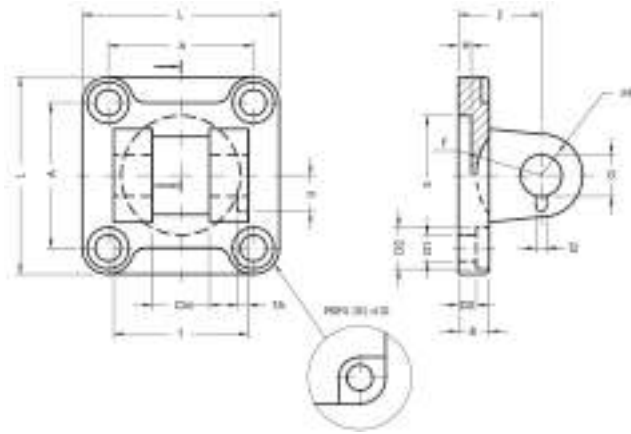

VCD

CHARNELA HEMBRA ESTRECHA PARA ARTICULACIÓN A ESCUADRA CON RÓTULA DIN648K
NARROW FEMALE HINGE FOR SQUARE JOINT WITH ARTICULATED HEAD DIN648K

Código / Code	Ø mm.	L	T	CM	A	Z	H	B	D3	S	G	MR	D1	D22	TA	TZ	LI	F
VCD032	32	45	34	14	32.5	22	5	9	5.5	30	10	10	6.6	11	3	3.3	11.5	17
VCD040	40	52	40	16	38	25	5	9	5.5	35	12	12	6.6	11	4	4.3	12	20
VCD050	50	65	45	21	46.5	27	5	11	6.5	40	16	14	9	15	4	4.3	14	22
VCD063	63	75	51	21	56.5	32	5	11	6.5	45	16	18	9	15	4	4.3	14	25
VCD080	80	95	65	25	72	36	5	14	10	45	20	20	11	18	4	4.3	16	30
VCD100	100	115	75	25	89	41	5	14	10	55	20	22	11	18	4	6.3	16	32
VCD125	125	140	97	37	110	50	7	20	10	60	30	25	14	20	6	6.3	24	42
VCD160	160	180	122	43	140	55	7	20	10	65	35	30	18	26	6	6.3	26.5	46
VCD200	200	220	122	43	175	60	7	25	11	75	35	30	18	26	6	6.3	26.5	49

MATERIAL: ACERO
MATERIAL: STEEL

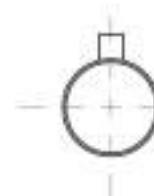
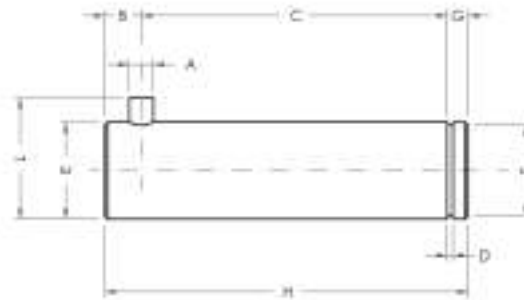

VPS

PERNO ANTIROTACIÓN PARA CHARNELA HEMBRA ESTRECHA VCD - PIN ANTI-ROTATION FOR NARROW FEMALE HINGE VCD

Código / Code	Ø mm.	A	C	D	E	F	G	H	L	B
VPS032	32	3	32.5	1.1	10	9.6	4	41	14	4.5
VPS040	40	4	38	1.1	12	11.5	4	48	16	6
VPS050	50	4	43	1.1	16	15.2	5	60	20	6
VPS063	63	4	49	1.1	16	15.2	5	60	20	6
VPS080	80	4	63	1.3	20	19	6	75	24	6
VPS100	100	4	73	1.3	20	19	6	85	24	6
VPS125	125	6	94	1.6	30	28.6	7	110	36	9
VPS160	160	6	119	1.6	35	33	7	135	41	9
VPS200	200	6	119	1.6	35	33	7	135	41	9

MATERIAL: ALUMINIO
MATERIAL: ALUMINIUM

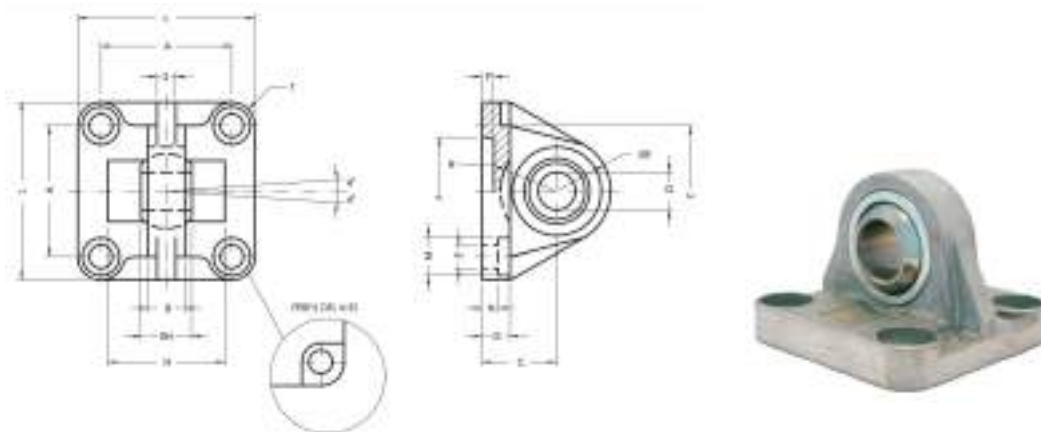

VCS

CHARNELA MACHO ESTRECHA CON RÓTULA DIN648K - NARROW MALE HINGE WITH ARTICULATED HEAD DIN648K

Código / Code	Ø mm.	A	B	C	D	EN	ER	F	G	E	L	M	N	P	H	R	S	Z	T
VCS032	32	32.5	10.5	22	10	14	16	30	9	6.6	45	11	5.5	5	-	-	4	32.5	6.25
VCS040	40	38	12	25	12	16	19	35	9	6.6	52	11	5.5	5	-	-	6	39	7
VCS050	50	46.5	15	27	16	21	21	40	11	9	65	15	6.5	5	51	18	8	47	9.25
VCS063	63	56.5	15	32	16	21	24	45	11	9	75	15	6.5	5	-	-	8	52	9.25
VCS080	80	72	18	36	20	25	28.5	45	14	11	95	18	10	5	72	24	10	67	11.5
VCS100	100	89	18	41	20	25	30	55	14	11	115	18	10	8	-	-	10	77	13
VCS125	125	110	25	50	30	37	40	60	20	13.5	140	20	10	7	-	-	13	98	15
VCS160	160	140	28	55	35	43	45	65	20	18	180	26	10	7	-	-	14	130	20
VCS200	200	175	28	60	35	43	48	75	25	18	220	26	11	7	-	-	14	155	22.5

MATERIAL: ACERO
MATERIAL: STEEL

TRATAMIENTO: CATAFORESIS NEGRA
TREATMENT: BLACK CATAPHORESIS

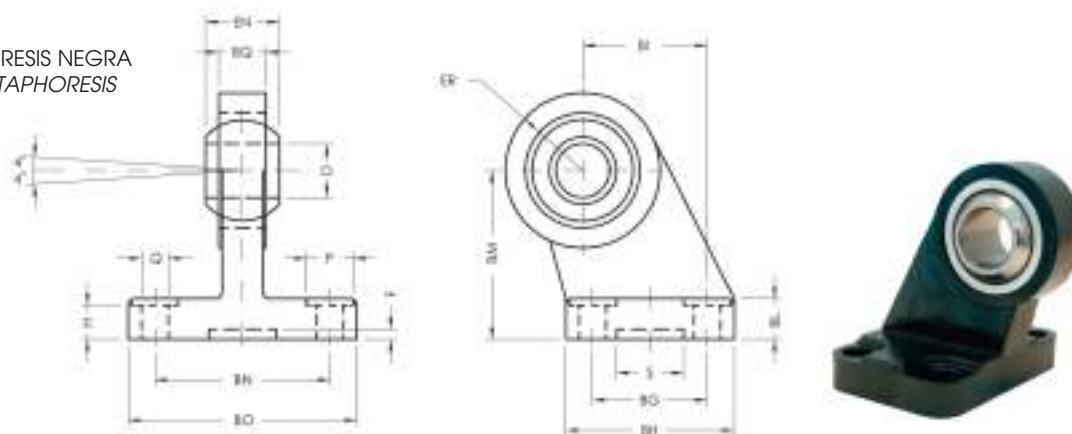

VAD

ARTICULACIÓN A ESCUADRA CON RÓTULA DIN648K - SQUADRE JOINT WITH ARTICULATED HEAD DIN648K

Código / Code	Ø mm.	Q	P	BG	BH	BI	BL	BM	BN	BO	EN	ER	BQ	D	H	S	F
VAD032	32	6.6	11	18	31	21	10	32	38	51	14	15	10.5	10	8.5	20	3
VAD040	40	6.6	11	22	35	24	10	36	41	54	16	18	12	12	8.5	20	3
VAD050	50	9	15	30	45	33	12	45	50	65	21	20	15	16	10.5	20	3
VAD063	63	9	15	35	50	37	12	50	52	67	21	23	15	16	10.5	20	3
VAD080	80	11	18	40	60	47	14	63	66	86	25	27	18	20	11.5	20	3
VAD100	100	11	18	50	70	55	15	71	76	96	25	30	18	20	12.5	20	3
VAD125	125	13.5	20	60	90	70	20	90	94	124	37	40	25	30	17	20	3

MATERIAL: ACERO
MATERIAL: STEEL

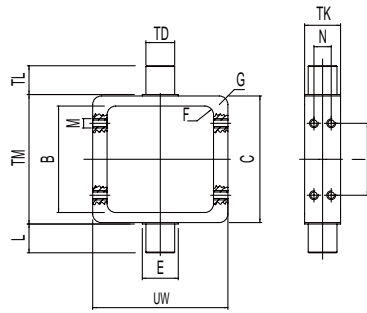

XCN

CHARNELA INTERMEDIA - INTERMEDIATE HINGE

Código / Code	Ø mm.	UW	B	C	TD	E	F	G	TK	I	TL	M	N	TM
XCN032	32	70	45	50	12	-	5	4	18	28	12	M5	7	50
XCN040	40	78	53	62	16	20	5	5	20	32	16	M5	8	63
XCN050	50	91	64	74	16	20	6	6	20	40	16	M6	8	75
XCN063	63	94	74	88	20	25	6	6	25	50	20	M6	12	90
XCN080	80	130	93	109	20	25	7	7	25	64	20	M8	12	110
XCN100	100	145	110	130	25	30	8	8	30	80	25	M8	15	132
XCN125	125	154	134	155	25	32	8	8	32	100	25	M10	15	160

MATERIAL: ACERO
MATERIAL: STEEL

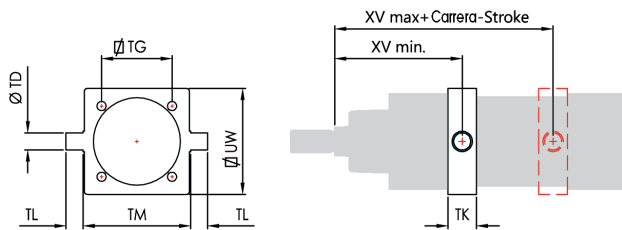

VCNT

CHARNELA INTERMEDIA - INTERMEDIATE HINGE

Código / Code	Ø mm.	TD	TG	TK	TL	TM	UW	XV min	XV max
VCNT032	32	12	32.5	15	12	50	46	61.5	84.5
VCNT040	40	16	38	20	16	63	59	71.5	93.5
VCNT050	50	16	46.5	20	16	75	69	78.5	101.5
VCNT063	63	20	56.5	25	20	90	84	84.5	110.5
VCNT080	80	20	72	25	20	110	102	94.5	125.5
VCNT100	100	25	89	30	25	132	125	107	133
VCNT125	125	25	110	32	25	160	155	126	163
VCNT160	160	32	140	40	32	200	190	149	191
VCNT200	200	32	175	40	32	250	240	164	206
VCNT250	250	40	220	50	40	320	296	187	223

MATERIAL: ACERO
MATERIAL: STEEL

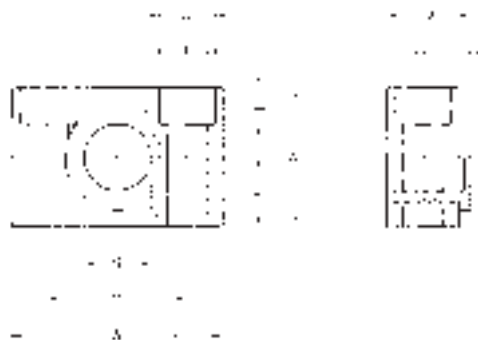

VSI

SOPORTE PARA CHARNELA INTERMEDIA - SUPPORT FOR INTERMEDIATE HINGE

Código / Code	Ø mm.	A	M	R	P	C	S	L	U	T	E
VSI032	32	46	18	30	15	32	12	10.5	11	6.6	7
VSI040	40 - 50	55	21	36	18	36	16	12	15	9	9
VSI063	63 - 80	65	23	40	20	42	20	13	18	11	11
VSI100	100 - 125	75	28.5	50	25	50	25	16	20	14	13
VSI160	160 - 200	92	40	60	30	60	32	22.5	26	18	17
VSI250	250	140	56	70	35	90	40	31	33	22	20

MATERIAL: ALUMINIO
MATERIAL: ALUMINIUM

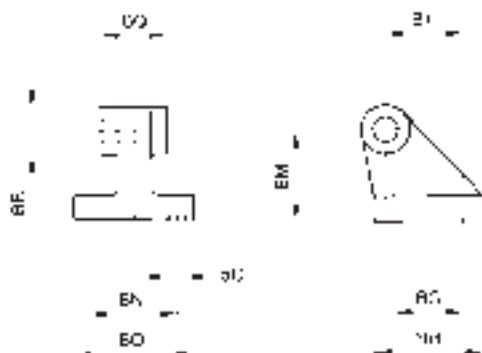

VAS

ARTICULACIÓN A ESCUADRA - SQUARE JOINT

Código / Code	Ø mm.	Q	BG	BH	B1	BM	BN	BO	BQ	BR
VAS032	32	6.6	18	31	21	32	38	51	26	20
VAS040	40	6.6	22	35	24	36	41	54	28	22
VAS050	50	9	30	45	33	45	50	65	32	26
VAS063	63	9	35	50	37	50	52	67	40	30
VAS080	80	11	40	60	47	63	66	86	50	30
VAS100	100	11	50	70	55	71	76	96	60	38
VAS125	125	14	60	90	70	90	94	124	70	45
VAS160	160	14	88	126	97	115	118	156	90	63
VAS200	200	18	90	130	105	135	122	162	90	63

MATERIAL: ACERO
MATERIAL: STEEL

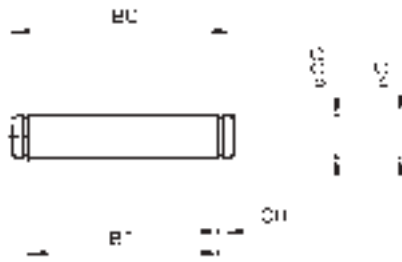

VPE

PERNO PARA CHARNELA CON SEEGER - PIN WITH SEEGER

Código / Code	Ø mm.	G	BT	BU	CG	CH
VPE032	32	10	46	53	9.6	1.1
VPE040	40	12	53	60	11.5	1.1
VPE050	50	12	61	68	11.5	1.1
VPE063	63	16	71	78	15.2	1.1
VPE080	80	16	91	98	15.2	1.1
VPE100	100	20	111	118	19	1.3
VPE125	125	25	132	139	23.9	1.3
VPE160	160	30	171.5	178	28.6	1.6
VPE200	200	30	171.5	178	28.6	1.6
VPE250	250	40	202	211	37.5	1.85
VPE320	320	45	222	236	42.5	1.85

MATERIAL: ACERO
MATERIAL: STEEL



FC

HORQUILLA CON CLIPS EN ACERO ZINCADO - YOKE WITH LOCABLE PIN

Código / Code	Ø mm.	A	B	C	E	F	G	KK
FC025	25 - 32	52	20	40	20	10	10	M10x1.25
FC040	40	62	24	48	24	12	12	M12x1.25
FC050	50 - 63	83	32	64	32	16	16	M16x1.5
FC080	80 - 100	105	40	80	40	20	20	M20x1.5
FC125	*125	148	56	110	55	30	30	M27x2
FC160	160 - 200	188	72	144	70	35	35	M36x2
FC250	250	232	84	168	85	42	42	M42x2
FC320	320	265	96	192	96	50	50	M48x2

* Con perno y seeger - With pin and seeger

MATERIAL: ACERO
MATERIAL: STEEL

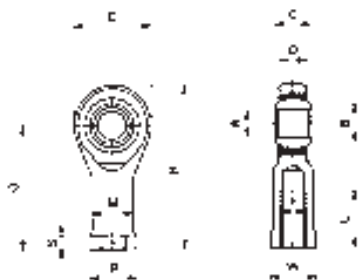

TF

RÓTULA AUTOLUBRICANTE - ROD ENDS SELF-LUBRICATING

Código Code	Ø mm.	A	B	C	Ø	D	E	F	G	H	L	M	P	S	W	Carga radial		Peso
																Dinámico	Estático	
		H7	0	0 -0,13	ESFERA	±0,13	±0,5		±0,5		±0,7	±0,7	±0,5	-0,7	+0,2 ±0,25	kg	kg	g
TF025	25 - 32	10	12,9	14	19,05	11,5	30	M10x1,25	43	58	15	15	19	6,5	16	1.200	3.100	88
TF040	40	12	15,4	16	22,23	12,5	34	M12x1,25	50	67	18	17,5	22	6,5	18	1.400	3.700	120
TF050	50 - 63	16	19,3	21	28,58	15,5	42	M16x1,5	64	85	24	22	27	8	24	2.500	6.300	240
TF080	80 - 100	20	24,4	25	34,93	18,5	50	M20x1,5	77	102	30	27,5	34	10	30	3.700	8.300	430
TF125	125	28	32,3	35	47,59	26	66	M27x2	103	136	41	37	46	14	41	7.100	14.200	1.120
TF160	160 - 200	35	-	43	-	-	-	M36x2	125	-	56	-	58	-	-	-	-	1.600
TF250	250	40	-	49	-	-	-	M42x2	142	-	60	-	65	-	-	-	-	2.800
TF320	320	50	-	60	-	-	-	M48x2	162	-	65	-	75	-	-	-	-	5.000

MATERIAL: ACERO
MATERIAL: STEEL

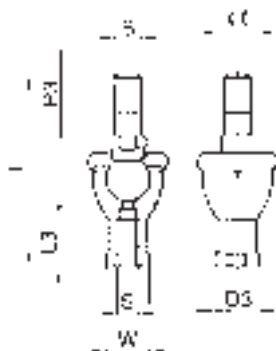

TS

HORQUILLA AUTOALINEANTE - SNODABLE YOKE

Código / Code	Ø mm.	S	L	L3	W	P3	D3	α°
TS025	25 - 32	M10x1.25	74.5	18	17	15	28	30°
TS040	40	M12x1.25	84	20	19	17	32	30°
TS050	50 - 63	M16x1.5	112	27	22	23	40	22°
TS080	80 - 100	M20x1.5	133	38	30	25	45	15°

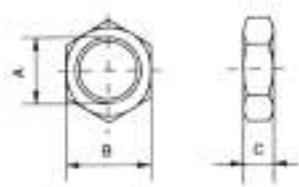
DA
TUERCA PARA VÁSTAGO - NUT FOR RODS

Código / Code	Ø mm.	A	B	C
ODA000051C9ZI	25	M10x1.25	17	8
ODA000051C9ZI	32	M10x1.25	17	8
ODA000051D5ZI	40	M12x1.25	19	7
ODA000051E3ZI	50	M16x1.5	22	6
ODA000051E3ZI	63	M16x1.5	22	6
ODA000051F2ZI	80 - 100	M20x1.5	30	9
ODA000051G8ZI	125	M27x2	41	12
EDA000051I6ZI	160 - 200	M36x2	55	18
EDA000051L0ZI	250	M42x2	65	20
EDA000051DGZI	320	M48x2	75	24

Unidades de Guiado / Guide Units

Las unidades de guiado son accesorios para cilindros de la norma ISO 6431 VDMA, ISO 15552 y ISO 6432. Son utilizadas en el caso de necesitar mover grandes cargas a una velocidad de movimiento elevada con posicionamiento de precisión. Gracias a esta precisión las unidades de guiado son apropiadas para crear sistemas de carga para maquina-herramienta, para embalaje y manipulación en general. Las unidades de guiado están disponibles para los siguientes cilindros:

Diámetros: De 12 a 100 mm
Carreras: De 50 a 500 mm

ISO 6431 VDMA (Ø32-Ø100)
ISO 6432 (Ø12-Ø25)

The guide units are accessories for cylinders ISO 6431 VDMA and ISO 6432. They have to be used in case high loads have to be moved at high translation speed with precision locating. Thanks to this precision, the guide units are particularly suitable to create loading system for tooling machines, for packing operations and generally speaking to realise manipulations units. The guide units are available for the following cylinders:

Bores: From 12 to 100 mm
Strokes: From 50 to 500 mm

ISO 6431 VDMA (Ø32-Ø100)
ISO 6432 (Ø12-Ø25)



Ejemplo de pedido / How to Order



Gráfico Unidades de Guiado / Charts Guide Units

Art. MLCHB
Unidad de guiado con cojinetes de bronce
Guide units with self lubricating sintered bush



Art. VLCHB
Unidad de guiado con cojinetes de bronce
Guide units with self lubricating sintered bush

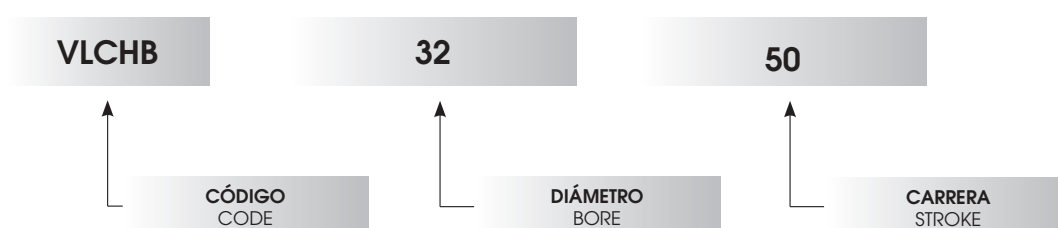
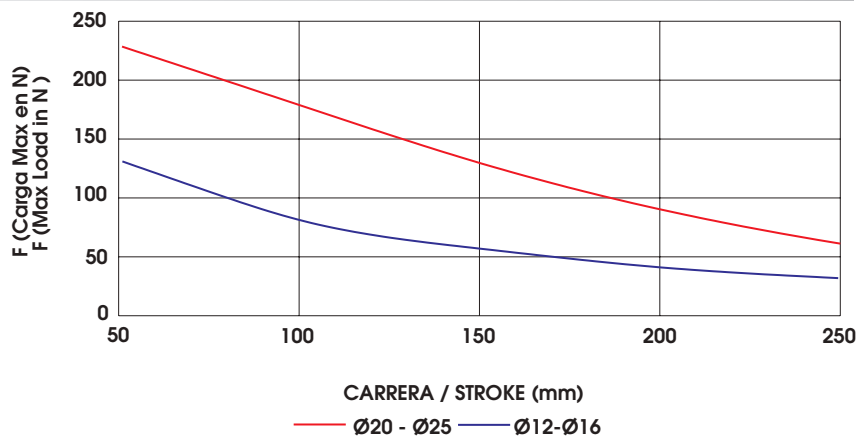
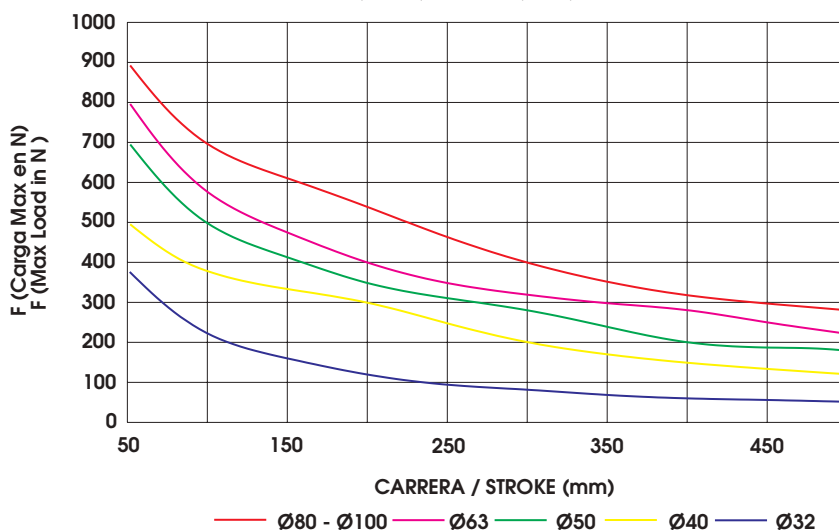

Art. MLCHC
Unidad de guiado con cojinetes de bolas
Guide units with recirculating ball bearing

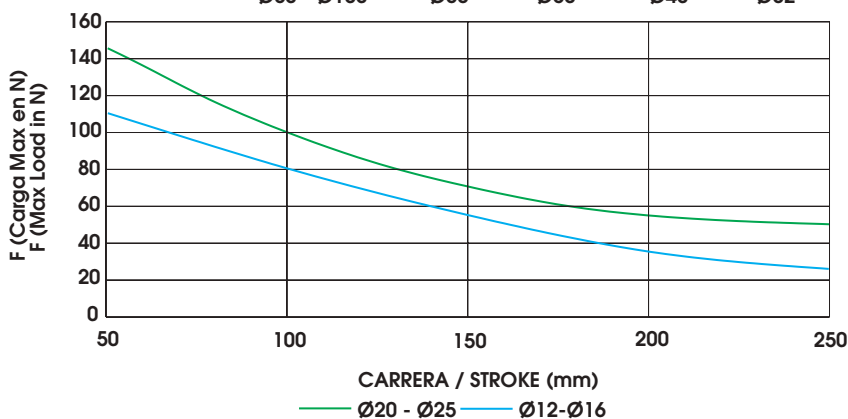

Art. VLCHC
Unidad de guiado con cojinetes de bolas
Guide units with recirculating ball bearing

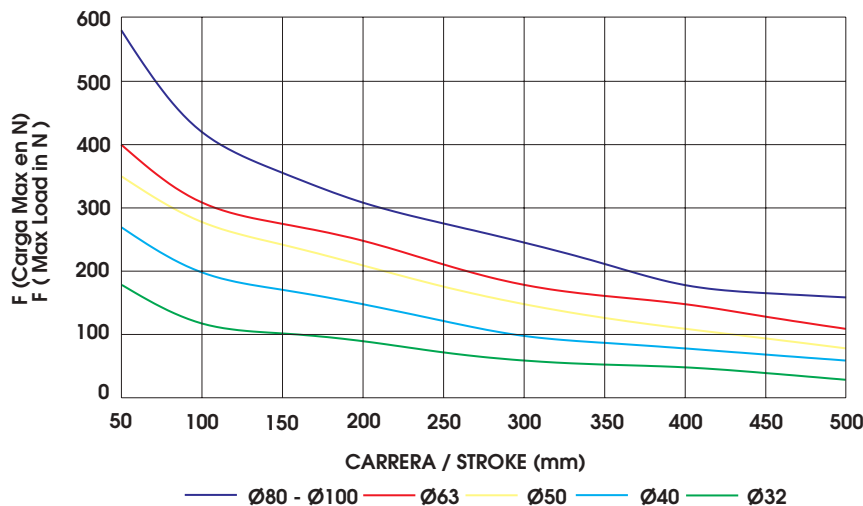

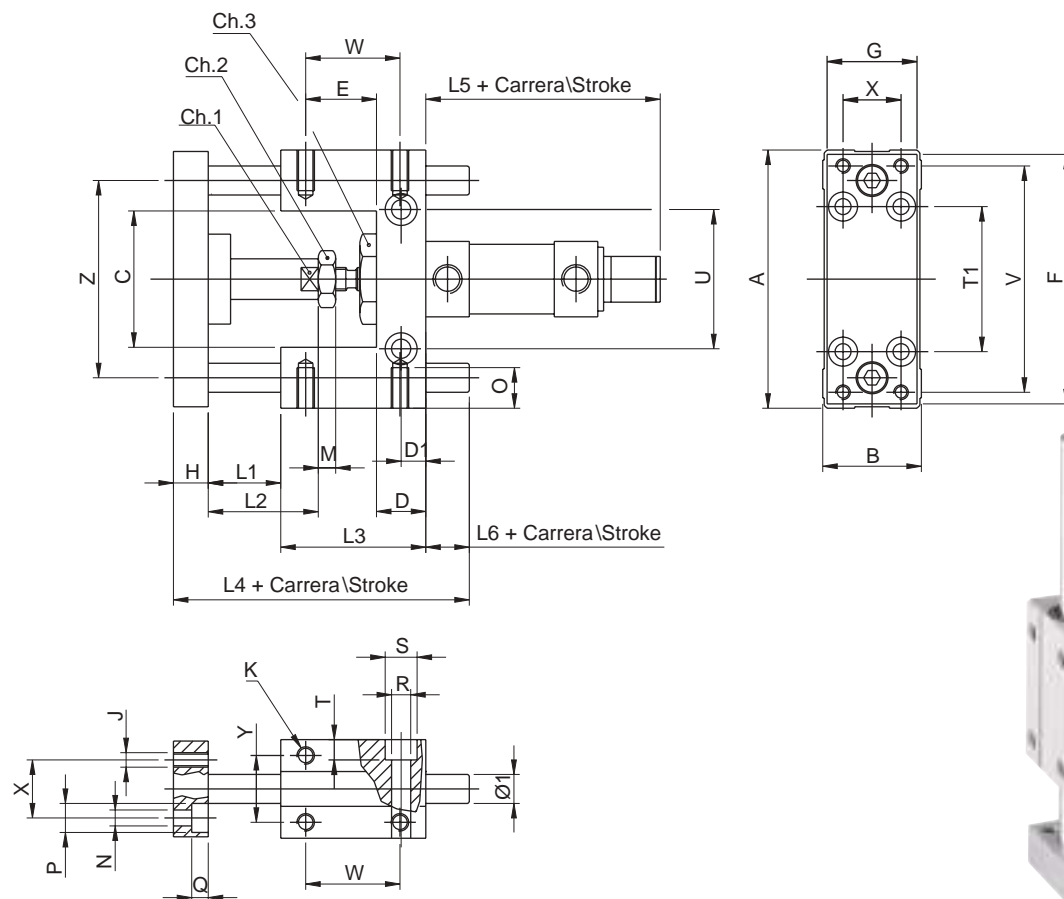

Ø mm.	A	B	C	Ch1	Ch2	Ch3	D	D1	E	F	G	H	Ø1	J	K	L1	L2	L3	L4	L5	L6
12 - 16	69	30	30	8	10	24	12	5.5	19.5	66	29	10	10	M4	M4	3	15	38	66.5	73	15.5
20	79	34	37	12	13	27	17	8.75	24.25	78	32	12	12	M5	M6	5	18	48	83	87	18
25	79	34	37	12	17	27	17	8.75	24.25	78	32	12	12	M5	M6	5	18	48	83	91	18

Ø mm.	M	N	O	P	Q	R	S	T	T1	U	V	W	X	Y	Z
12 - 16	6	4.5	6	7.5	4.5	5.5	9	5.5	32	24	58	25	18	22	49.5
20	8	5.5	9	10	7.5	6.5	11	6.5	38	38	68	32.5	20	23	58
25	8	5.5	9	10	7.5	6.5	11	6.5	38	38	68	32.5	20	23	58

MLCUB

UNIDAD DE GUIADO TIPO "U" CON COJINETES DE BRONCE
GUIDE UNIT "U" WITH SELF LUBRICATING SINTERED BRONZE

ISO6432

CARRERAS STANDARD mm. - STD STROKES

Ø mm.	50	100	160	200
12 - 16	X	X	X	X
20	X	X	X	X
25	X	X	X	X

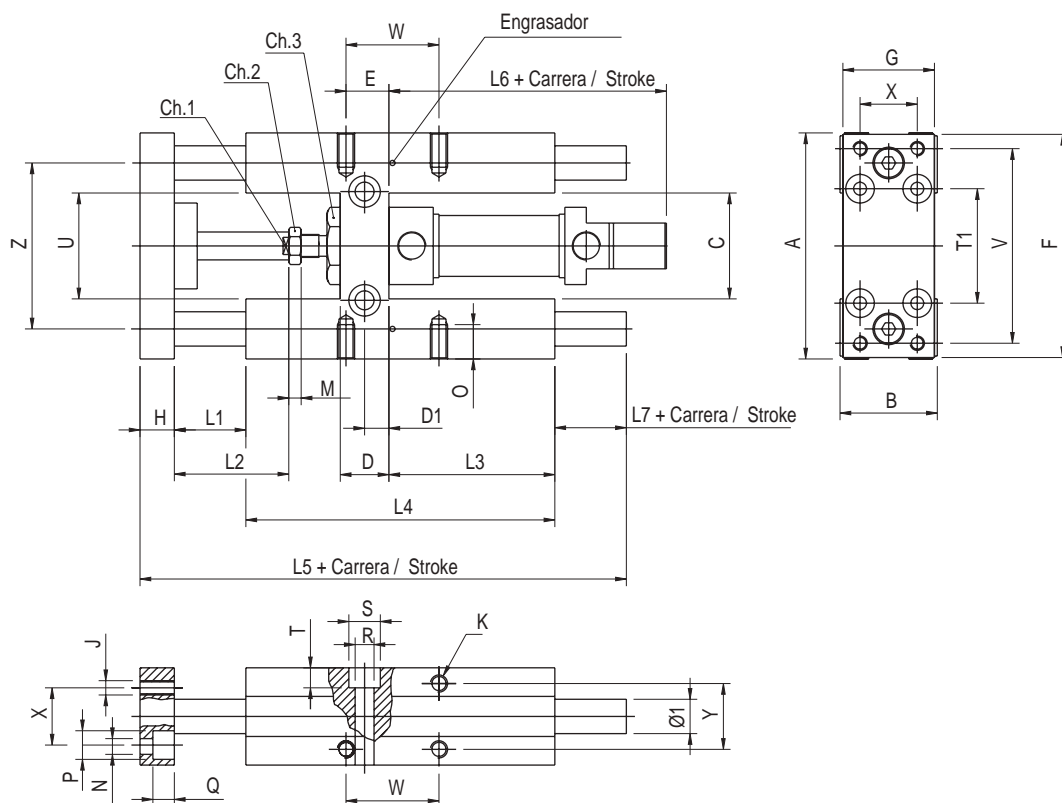

Ø mm.	A	B	C	Ch1	Ch2	Ch3	D	D1	E	F	G	H	Ø1	J	K	L1	L2	L3	L4	L5	L6
12 - 16	69	30	30	8	10	24	12	6	8	66	29	10	10	M4	M4	25	18	46	68	123.5	73
20	79	34	37	12	13	27	17	8.5	15	78	32	12	12	M5	M6	25	40	58	108	166	87
25	79	34	37	12	17	27	17	8.5	15	78	32	12	12	M5	M6	25	40	58	108	166	91

Ø mm.	L7	M	N	O	P	Q	R	S	T	T1	U	V	W	X	Y	Z
12 - 16	12	6	4.5	6	8	4.5	5.5	9	5.5	32	24	58	18	18	22	49.5
20	10	8	5.5	9	10	7.5	6.5	11	6.5	38	38	68	32.5	20	23	58
25	10	8	5.5	9	10	7.5	6.5	11	6.5	38	38	68	32.5	20	23	58

MLCHB

UNIDAD DE GUIADO TIPO "H" CON COJINETES DE BRONCE
GUIDE UNIT "H" WITH SELF LUBRICATING SINTERED BRONZE

ISO6432

CARRERAS STANDARD mm. - STD STROKES

Ø mm.	50	100	160	200	250
12 - 16	X	X	X	X	X
20	X	X	X	X	X
25	X	X	X	X	X

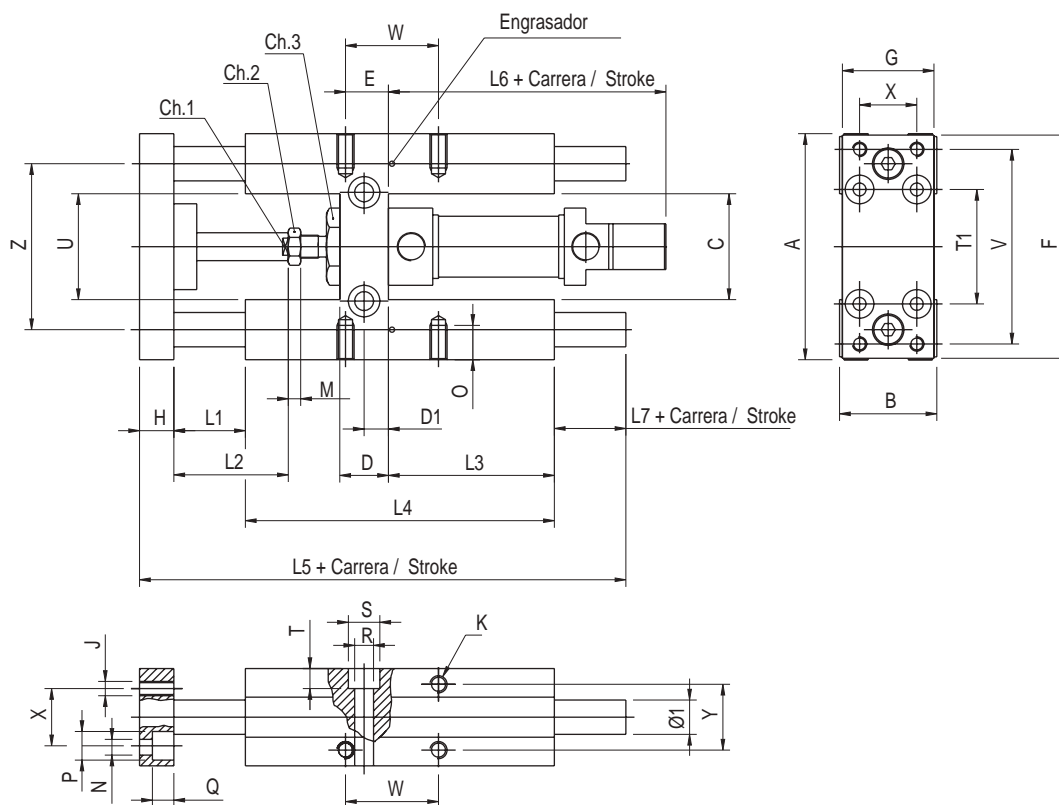

Ø mm.	A	B	C	Ch1	Ch2	Ch3	D	D1	E	F	G	H	Ø1	J	K	L1	L2	L3	L4	L5	L6
12 - 16	69	30	30	8	10	24	12	6	8	66	29	10	10	M4	M4	25	18	46	68	123.5	73
20	79	34	37	12	13	27	17	8.5	15	78	32	12	12	M5	M6	25	40	58	108	166	87
25	79	34	37	12	17	27	17	8.5	15	78	32	12	12	M5	M6	25	40	58	108	166	91

Ø mm.	L7	M	N	O	P	Q	R	S	T	T1	U	V	W	X	Y	Z
12 - 16	12	6	4.5	6	8	4.5	5.5	9	5.5	32	24	58	18	18	22	49.5
20	10	8	5.5	9	10	7.5	6.5	11	6.5	38	38	68	32.5	20	23	58
25	10	8	5.5	9	10	7.5	6.5	11	6.5	38	38	68	32.5	20	23	58

MLCHC

UNIDAD DE GUIADO TIPO "H" CON COJINETES DE BOLAS
GUIDE UNIT "H" WITH RECIRCULATING BALL SLEEVES

ISO6432

CARRERAS STANDARD mm. - STD STROKES

Ø mm.	50	100	160	200	250
12 - 16	X	X	X	X	X
20	X	X	X	X	X
25	X	X	X	X	X

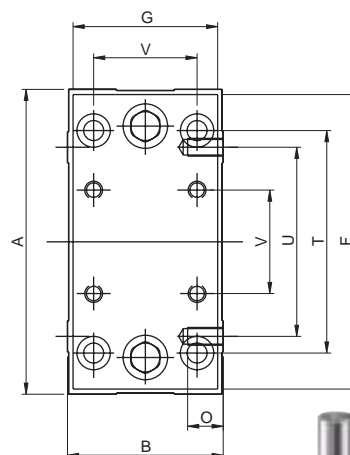
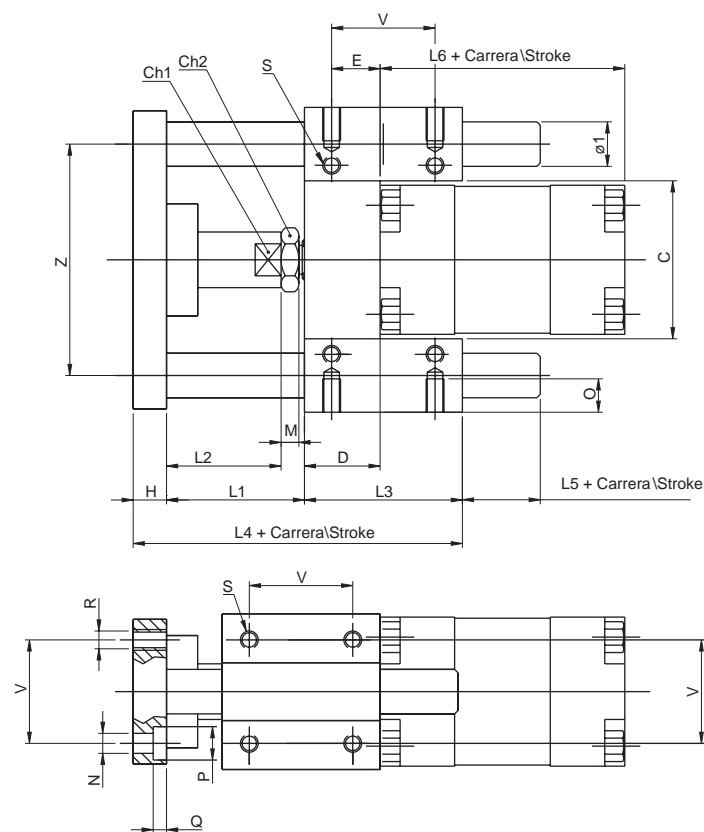

Ø mm.	A	B	C	Ch1	Ch2	D	E	F	G	H	Ø1	L1	L2	L3	L4	L5	L6	M	N	O
32	97	49	51	15	17	17	9.25	93	45	12	12	42	25	48	102	18	97	8	6.6	12
40	115	58	58.5	15	19	21	11	112	55	12	16	43	24	58	113	17	109	7	6.6	12
50	137	70	70.2	20	24	25	18.8	134	65	15	20	49	30	59	123	20	110	6	9	16
63	152	85	85.2	20	24	25	15.3	147	80	15	20	49	30	76	140	21	125	6	9	16

Ø mm.	P	Q	R	S	T	U	V	Z
32	11	6.5	M6	M6	78	61	32.5	74
40	11	6.5	M6	M6	84	69	38	87
50	15	8.5	M8	M8	100	85	46.5	104
63	15	9	M8	M8	105	100	56.5	119

VLCUB

ISO6431

UNIDAD DE GUIADO TIPO "U" CON COJINETES DE BRONCE
 GUIDE UNIT "U" WITH SELF LUBRICATING SINTERED BRONZE

CARRERAS STANDARD mm. - STD STROKES

Ø mm.	50	100	160	200	250	320	400	500
32	X	X	X	X	X	X	X	X
40	X	X	X	X	X	X	X	X
50	X	X	X	X	X	X	X	X
63	X	X	X	X	X	X	X	X

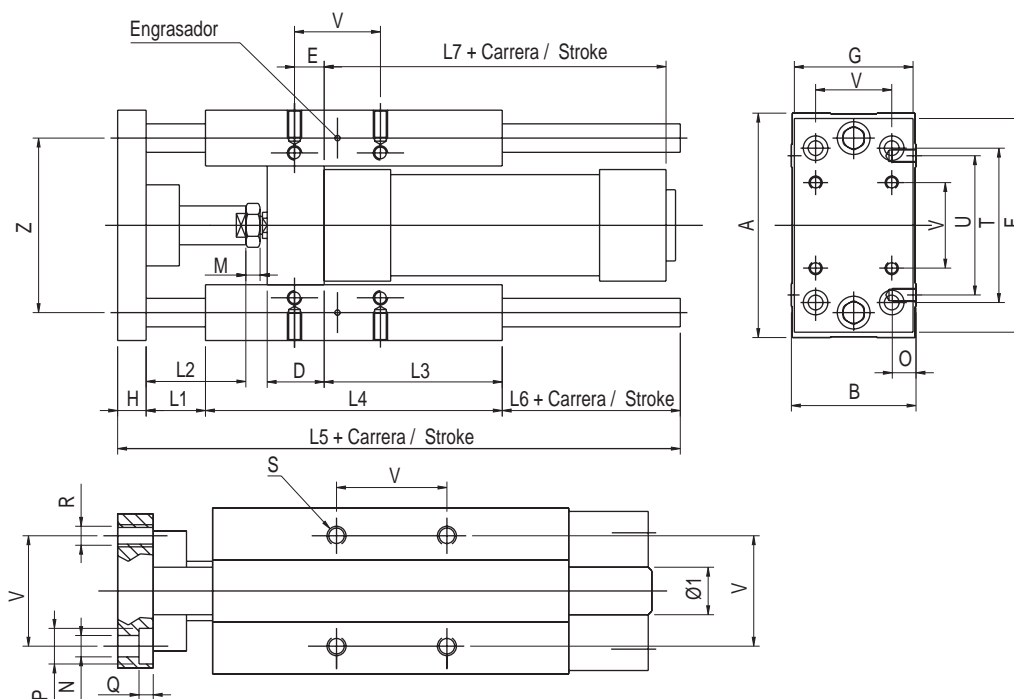

Ø mm.	A	B	C	Ch1	Ch2	D	E	F	G	H	Ø1	L1	L2	L3	L4	L5	L6	L7	M	N	O
32	97	49	51	15	17	24	4.3	93	45	12	12	25	42	75	125	187	25	97	8	6.6	12
40	115	58	58.2	15	19	28	11	112	55	12	16	25	42	80	140	207	30	109	7	6.6	12
50	137	70	70.2	20	24	34	18.8	134	65	15	20	25	50	78	148	223	35	110	6	9	16
63	152	85	85.2	20	24	34	15.3	147	80	15	20	25	50	106	178	243	25	125	6	9	16
80	189	105	105.5	26	30	50	25	180	100	20	25	25	50	111	195	267	27	133	9	11	20
100	213	130	130.5	26	30	55	30	206	120	20	25	25	50	128	218	290	27	144	9	11	20

Ø mm.	P	Q	R	S	T	U	V	Z
32	11	6.5	M6	M6	78	61	32.5	74
40	11	6.5	M6	M6	84	69	38	87
50	15	8.5	M8	M8	100	85	46.5	104
63	15	9	M8	M8	105	100	56.5	116
80	18	11	M10	M10	130	130	72	148
100	16.5	11	M10	M10	150	150	89	173

VLCHB

UNIDAD DE GUIADO TIPO "H" CON COJINETES DE BRONCE
GUIDE UNIT "H" WITH SELF LUBRICATING SINTERED BRONZE

ISO6431

CARRERAS STANDARD mm. - STD STROKES

Ø mm.	50	100	160	200	250	320	400	500
32	X	X	X	X	X	X	X	X
40	X	X	X	X	X	X	X	X
50	X	X	X	X	X	X	X	X
63	X	X	X	X	X	X	X	X
80	X	X	X	X	X	X	X	X
100	X	X	X	X	X	X	X	X

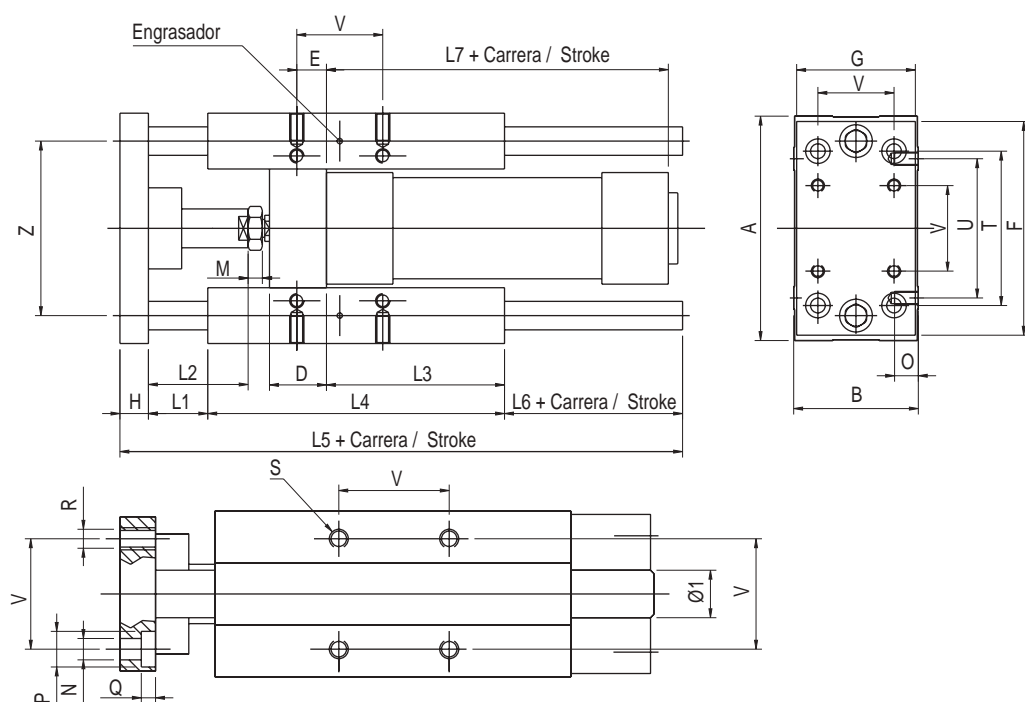

Ø mm.	A	B	C	Ch1	Ch2	D	E	F	G	H	Ø1	L1	L2	L3	L4	L5	L6	L7	M	N	O
32	97	49	51	15	17	24	4.3	93	45	12	12	25	42	75	125	187	25	97	8	6.6	12
40	115	58	58.2	15	19	28	11	112	55	12	16	25	42	80	140	207	30	109	7	6.6	12
50	137	70	70.2	20	24	34	18.8	134	65	15	20	25	50	78	148	223	35	110	6	9	16
63	152	85	85.2	20	24	34	15.3	147	80	15	20	25	50	106	178	243	25	125	6	9	16
80	189	105	105.5	26	30	50	25	180	100	20	25	25	50	111	195	267	27	133	9	11	20
100	213	130	130.5	26	30	55	30	206	120	20	25	25	50	128	218	290	27	144	9	11	20

Ø mm.	P	Q	R	S	T	U	V	Z
32	11	6.5	M6	M6	78	61	32.5	74
40	11	6.5	M6	M6	84	69	38	87
50	15	8.5	M8	M8	100	85	46.5	104
63	15	9	M8	M8	105	100	56.5	116
80	18	11	M10	M10	130	130	72	148
100	16.5	11	M10	M10	150	150	89	173

VLCHC

ISO6431

UNIDAD DE GUIADO TIPO "H" CON COJINETES DE BOLAS

GUIDE UNIT "H" WITH RECIRCULATING BALL SLEEVES

CARRERAS STANDARD mm. - STD STROKES

Ø mm.	50	100	160	200	250	320	400	500
32	X	X	X	X	X	X	X	X
40	X	X	X	X	X	X	X	X
50	X	X	X	X	X	X	X	X
63	X	X	X	X	X	X	X	X
80	X	X	X	X	X	X	X	X
100	X	X	X	X	X	X	X	X

Sensores Magnéticos Serie DSL / Magnetic Switches DSL Serie

Sensores DSL con inserción longitudinal para los siguientes modelos de cilindro:

DSL sensor lengthwise assembly for the following models of cylinders:

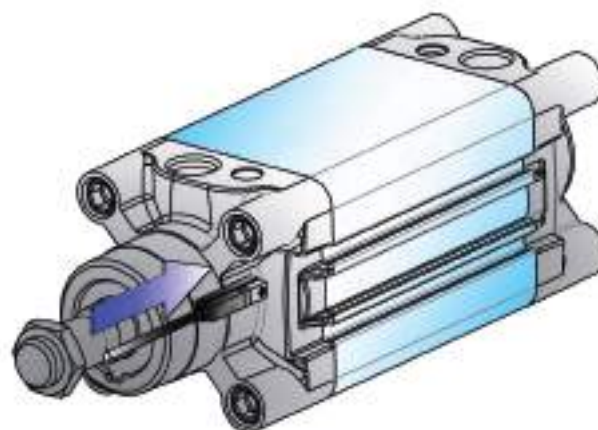

Minicilindros / Mini Cylinders



Minicilindros Inox / Mini Cylinders Inox



Cilindros A95 / Cylinders A95



Cilindros Compactos / Compact Cylinders



Cilindros Carrera Corta / Short Stroke









Cilindros Serie X / Cylinders X Series



Cilindros Serie X / Cylinders X Series

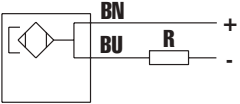
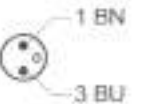
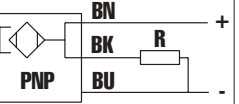

Características técnicas / Technical data

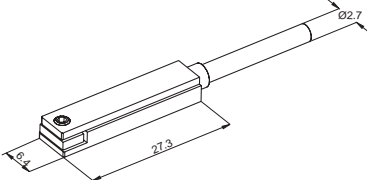
DESCRIPCIÓN DESCRIPTION	VERSIÓN REED - REED VERSION		VERSIÓN HALL - HALL VERSION	
	CÓDIGO CODE: DSL1C225	CÓDIGO CODE: DSL1M8	CÓDIGO CODE: DSL4C225	CÓDIGO CODE: DSL4M8
				
CONEXIÓN Connection	CABLE Cable	CONECTOR M8 M8 Connection	CABLE Cable	CONECTOR M8 M8 Connection
VOLTAJE DE TRABAJO Voltage range	3-130 V. AC/DC	3-130 V. AC/DC	10-30 V. DC	10-30 V. DC
CORRIENTE MAX. A 25° C Max current at 25°C	50 mA	50 mA	200 mA	200 mA
POTENCIA MAX./CARGA RESISTIVA Max power/resistive load	10W	10W	6W	6W
CAIDA DE TENSIÓN MAX. Max voltage drop	3.2V	3.2V	0.8V	0.8V
CONTACTO DE SALIDA Contact type	N.O.	N.O.	N.O.	N.O.
SEÑAL DE CONMUTACION Output status indicator	LED AMARILLO/yellow	LED AMARILLO/yellow	LED AMARILLO/yellow	LED AMARILLO/yellow
TIEMPO DE RESPUESTA Response time	0.5 ms max	0.5 ms max	0.2 ms max	0.2 ms max
TIEMPO DE DESCONEXIÓN Decay time	0.1 ms max	0.1 ms max	0.1 ms max	0.1 ms max
VIDA ELÉCTRICA (CARGA RESISTIVA) Electric life (resistive load)	4x10 ⁷	4x10 ⁷	4x10 ⁷	4x10 ⁷
TIPO DE CABLE Cable type	PVC	PVC	PVC	PVC
TEMPERATURA DE TRABAJO Working temperature	-20 +70°C	-20 +70°C	-20 +70°C	-20 +70°C
GRADO DE PROTECCIÓN Protection degree	IP 68	IP 68	IP 68	IP 68
LONGITUD CABLE Cable length	2.5mf.	0.3mf.	2.5mf.	0.3mf.
SALIDA OUTPUT	-	-	PNP	PNP
COLOR CABLE Cable colour	NEGRO black	NEGRO black	NEGRO black	NEGRO black
CABLES Wires	2	2	3	3
TRANSISTOR SOBREENSIDAD Overcurrent transients	Si-Yes	Si-Yes	No	No
TRANSISTOR SOBREVOLTAJE Overvoltage transients	No	No	No	No
INVERSOR DE POLARIDAD Polarity reversal	Si-Yes	Si-Yes	Si-Yes	Si-Yes
CORTOCIRCUITO Short circuit	No	No	No	No
RESISTENCIA A LA CORROSIÓN Corrosion resistance	3	3	3	3
NORMATIVA ATEX explosion ATEX	No	No	No	No
TIPO DE RANURA Slot type	T	T	T	T
TIPO DE MONTAJE EN CILINDRO Type of mounting to the cylinder	SOLO LONGITUDINAL Longitudinal only	SOLO LONGITUDINAL Longitudinal only	SOLO LONGITUDINAL Longitudinal only	SOLO LONGITUDINAL Longitudinal only
ESQUEMA CIRCUITO Circuit diagram				
DISEÑO DRAW				

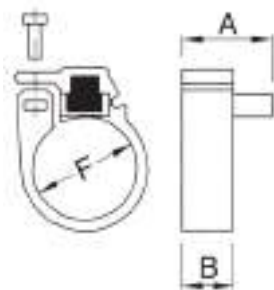
Soporte para sensores DSL para minicilindros ISO 6432 y cilindros serie A95
Bracket for DSL to use with minicylinders ISO 6432 and Cylinders A95 Serie

Código / Code	Ø mm.	F = Ø	A	B
MFX008	8	9.4 mm	14	8
MFX010	10	11.3 mm	14	8
MFX012	12	13.3 mm	14	8
MFX016	16	17.3 mm	14	8
MFX020	20	21.3 mm	14	8
MFX025	25	26.3 mm	14	8
AFX032	32	33.5 mm	14	8
AFX040	40	41.5 mm	14	8
AFX050	50	52 mm	14	8
AFX063	63	65 mm	14	8

Prolongación a tres hilos / Three Wires Extension

PX

CODE	LONGITUD / LENGTH
PX3000	3000 mm
PX5000	5000 mm

Sensores Magnéticos Serie DSH / Magnetic Switches DSH Serie

Sensores DSH con montaje superior para los siguientes modelos de cilindro:

DSH sensor above assembly for the following models of cylinders:

Minicilindros / Mini Cylinders



Minicilindros Inox / Mini Cylinders Inox



Cilindros Carrera Corta / Short Stroke



Cilindros Serie X / Cylinders X Series



Cilindros Serie NHA / Cylinders NHA Series



Cilindros Compactos / Compact Cylinders

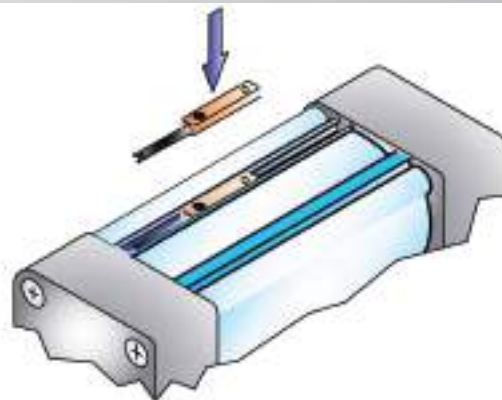

Cilindros Serie X / Cylinders X Series



Cilindros Serie E / Cylinders E Series



Cilindros Serie P / Cylinders P Series



Caratteristiche tecniche / Technical data

DESCRIPCIÓN DESCRIPTION	VERSIÓN REED - REED VERSION		VERSION ELECTRÓNICA ELECTRONIC VERSION	
	CÓDIGO CODE : DSH2R2F20	CÓDIGO CODE : DSH2R2FM8	CÓDIGO CODE : DSH4H3F20	CÓDIGO CODE : DSH4H3FM8
CONEXIÓN Connection	CABLE Cable	CONECTOR M8 M8 Connection	CABLE Cable	CONECTOR M8 M8 Connection
VOLTAJE DE TRABAJO Voltage range	5-120 V. AC/DC	5-120 V. AC/DC	10-30 V. DC	10-30 V. DC
CORRIENTE MAX. A 25° C Max current at 25°C	100 mA	100 mA	100 mA	100 mA
POTENCIA MAX./CARGA RESISTIVA Max power/resistive load	10W	10W	-	-
CAIDA DE TENSIÓN MAX. Max voltage drop	<5V	<5V	<2.5V	<2.5V
CONTACTO DE SALIDA Contact type	N.O.	N.O.	N.O. PNP	N.O. PNP
SEÑAL DE CONMUTACION Output status indicator	LED AMARILLO/yellow	LED AMARILLO/yellow	LED AMARILLO/yellow	LED AMARILLO/yellow
TIEMPO DE RESPUESTA Response time	0.5 ms max	0.5 ms max	-	-
TIEMPO DE DESCONEXIÓN Decay time	0.1 ms max	0.1 ms max	<30 ms	<30 ms
VIDA ELÉCTRICA (CARGA RESISTIVA) Electric life (resistive load)	10 ⁷	10 ⁷	INFINITA	INFINITA
TIPO DE CABLE Cable type	PVC	PVC	PUR	PUR
TEMPERATURA DE TRABAJO Working temperature	-20 +70°C	-20 +70°C	-25 +85°C	-25 +85°C
GRADO DE PROTECCIÓN Protection degree	IP 67 II	IP 67 II	IP 67	IP 67
LONGITUD CABLE Cable length	2.5mt.	0.3mt.	2 mt.	0.3mt.
SALIDA OUTPUT	-	-	-	-
COLOR CABLE Cable colour	NEGRO black	NEGRO black	NEGRO black	NEGRO black
CABLES Wires	2	2	3	3
TRANSISTOR SOBREENTENSIDAD Overcurrent transients	Si-Yes	Si-Yes	No	No
TRANSISTOR SOBREVOLTAJE Overvoltage transients	No	No	No	No
INVERSOR DE POLARIDAD Polarity reversal	Si-Yes	Si-Yes	Si-Yes	Si-Yes
CORTOCIRCUITO Short circuit	No	No	No	No
RESISTENCIA A LA CORROSIÓN Corrosion resistance	3	3	3	3
NORMATIVA ATEX explosion ATEX	No	No	No	No
TIPO DE RANURA Slot type	T	T	T	T
TIPO DE MONTAJE EN CILINDRO Type of mounting to the cylinder	AXIAL Y LONGITUDINAL Axial and Longitudinal	AXIAL Y LONGITUDINAL Axial and Longitudinal	AXIAL Y LONGITUDINAL Axial and Longitudinal	AXIAL Y LONGITUDINAL Axial and Longitudinal
ESQUEMA CIRCUITO Circuit diagram				
DISEÑO DRAW				

Soporte para sensores DSH para minicilindros ISO 6432
Bracket for DSH sensors to use with minicylinders ISO 6432

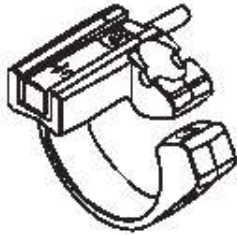

Código / Code	Ø mm.	F = Ø
MFH012	12	13.3 mm
MFH016	16	17.3 mm
MFH020	20	21.3 mm
MFH025	25	26.3 mm

Prolongación a tres hilos / Three Wires Extension



PX

CODE	LONGITUD / LENGTH
PX3000	3000 mm
PX5000	5000 mm

Sensores Magnéticos Serie DSN / Magnetic Switches DSH Serie

Características técnicas / Technical data

DESCRIPCIÓN <i>DESCRIPTION</i>	VERSIÓN REED <i>REED VERSION</i> CÓDIGO CODE: DSN0R2F20	VERSIÓN HALL <i>HALL VERSION</i> CÓDIGO CODE: DSN1H3F20
CONEXIÓN <i>Connection</i>	CABLE <i>Cable</i>	CABLE <i>Cable</i>
VOLTAJE DE TRABAJO <i>Voltage range</i>	3-250 V. AC/DC	10-30 V. DC
Corrente max a 25°C <i>Max current at 25°C</i>	1000 mA	200 mA
CORRIENTE MAX. A 25° C <i>Max power/resistive load</i>	50W	6W
CAIDA DE TENSIÓN MAX. <i>Max voltage drop</i>	2.7V	0.5V
CONTACTO DE SALIDA <i>Contact type</i>	N.O.	N.O. PNP
SEÑAL DE CONMUTACION <i>Output status indicator</i>	LED Rosso/red	LED Rosso/red
Tempo di inserzione <i>Response time</i>	0.5 ms max	0.2 ms max
TIEMPO DE RESPUESTA <i>Decay time</i>	0.1 ms max	0.1 ms max
VIDA ELÉCTRICA (CARGA RESISTIVA) <i>Electric life (resistive load)</i>	10 ⁷	10 ⁷
TIPO DE CABLE <i>Cable type</i>	PVC CEI 2022	PVC
TEMPERATURA DE TRABAJO <i>Working temperature</i>	-20 +70°C	-20 +70°C
GRADO DE PROTECCIÓN <i>Protection degree</i>	IP 65	IP 67
LONGITUD CABLE <i>Cable lenght</i>	2 mt.	3 mt.
COLOR CABLE <i>Cable colour</i>	NEGRO black	NEGRO black
CABLES <i>Wires</i>	2	3
TRANSISTOR SOBREINTENSIDAD <i>Overcurrent transients</i>	Si-Yes	Si-Yes
TRANSISTOR SOBREVOLTAJE <i>Overvoltage transients</i>	No	No
INVERSOR DE POLARIDAD <i>Polarity reversal</i>	Si-Yes	Si-Yes
CORTOCIRCUITO <i>Short circuit</i>	No	No
RESISTENCIA A LA CORROSIÓN <i>Corrosion resistance</i>	3	3
NORMATIVA ATEX <i>explosion ATEX</i>	No	No
TIPO DE MONTAJE EN CILINDRO <i>Type of mounting to the cylinder</i>	CON SOPORTE <i>With Bracket</i>	CON SOPORTE <i>With Bracket</i>
ESQUEMA CIRCUITO <i>Circuit diagram</i>		
DISEÑO <i>DRAW</i>		



Sensores DSN para cilindros con tirantes
DSN sensor for cylinders with tie rods

Soporte para sensores DSN para cilindros con tirantes / Bracket for DSN sensors to use with cylinders with tie rods

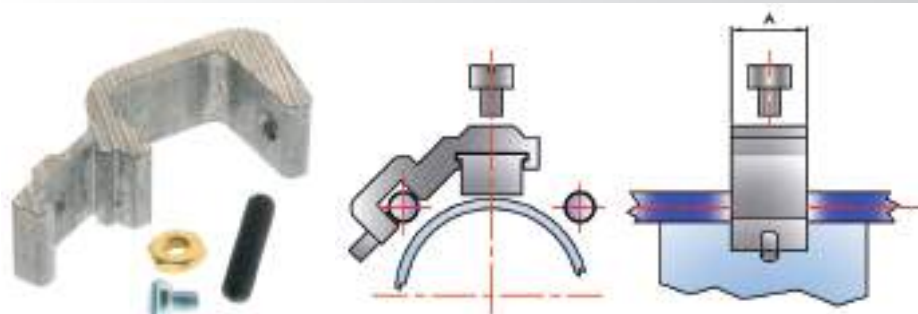

Código / Code	Ø mm.	A
DSN2XF032T	32-100	12
DSN2XF125T	125-160	12
DSN2XF200T	200-250	12



Serie **FRL**

COMPONENTES PARA EL TRATAMIENTO DEL AIRE COMPRIMIDO
AIR TREATMENT UNIT

17.5

T010 Mini

Filtro
Filter



17.6

T015 Mini

Filtro Coalescente
Coalescer Filter



17.7

T020 Mini

Regulador
Regulator



17.8

T070 Mini

Regulador Escape Rápido
Quick Exhaust Regulator



17.9

T080 Mini

Regulador Para Agua
Water Regulator



17.10

T030 Mini

Filtro Regulador
Filter Regulator



17.11

T040 Mini

Lubricador
Lubricator



17.12

T100 - T200 Mini

FR+L
F+R+L



17.13

T400 Mini

F+FC



17.14

T450 Mini

FR+FC



17.18

T010

Filtro
Filter



17.20

T015

Filtro Coalescente
Coalescer Filter



17.22



T020

Regulador
Regulator

17.24



T030

Filtro Regulador
Filter Regulator

17.26



T040

Lubricador
Lubricator

17.28



T050

Válvula De Corte
Shut Off Valve

17.30



Válvula De Arranque Progresivo
Soft Start Valve

T060

17.32



T100

FR+L

17.34



T110

V+FR+L

17.36



T200

F+R+L

17.38



T210

V+F+R+L

17.40



T300

F+L

17.42-44

T400 - T450

F+FC
FR+FC

T400



T450



17.46

Accesorios / Accessories



Instrucciones Técnicas Mini / Mini Technical Instruction

La unión de los componentes de la serie FRL debe seguir en líneas generales este orden: Filtro, Regulador, Lubricador. La conexión de los componentes se debe hacer siguiendo la dirección indicada por las flechas marcadas en la superficie superior de los componentes.

Generally the assembling of FRL components has to follow this order: Filter, Regulator, Lubricator. While connecting the components, be sure that the air flows towards the direction of the arrows located on the upper surface of the components.

La unión de los componentes se efectúa fácilmente efectuando los siguientes pasos:

- Insertar las tapas en el lugar indicado del cuerpo.
- Unir las partes asegurando que las juntas tóricas están colocadas correctamente.
- Apretar los tornillos sobre las placas.

The setting up of the parts has to be done as follows:

- Put the plates in the proper places of the bodies.
- Put the assembling parts together, making sure that the o-ring are in their proper seats.
- Tighten the screws on the plates.



Para regular la presión se deben seguir estas indicaciones:

- Tirar del pomo hasta llegar a la posición de regulación.
- Fijar la presión deseada para la salida girando el pomo.
- Presionar el pomo hasta la posición de bloqueo.

La colocación del manómetro debe realizarse manualmente y aplicando líquido sellante. El regulador de escape rápido permite la salida rápida al circuito cuando la presión es interrumpida.

To regulate the pressure follow these suggestions:

- raise the knob to the regulating position;
 - fix up the required pressure always upgrade then press the knob to the block position.
- The manometer has to be assembled manually with the addition of liquid sealant. The mini quick exhaust regulator allows the circuit downstream to exhaust rapidly when upstream pressure is interrupted.



El escape de la condensación, manual o semiautomática, se efectúa automáticamente cuando no hay presión en la taza, presionando la purga es posible hacer el escape de la condensación con presencia de presión, y girando la purga en sentido contrario a las agujas del reloj, el escape vuelve a posición cerrada.

The manual/semi-automatic condensate exhaust is normally in the open position; i.e. it exhausts automatically the condensate when there is no pressure inside the bowl. Pressing the knob it is possible to exhaust the condensate even if it is on pressure, turning the knob in anticlockwise sense the exhaust is in the close position.



Para añadir aceite en el lubricador, abriremos el tapón colocado en la pared superior o desenroscando el vaso, asegurándose de que no haya presión en el circuito. La regulación del aceite en el circuito se efectúa utilizando un destornillador sobre el tornillo del tapón, ajustándolo a una gota cada 300/600 NI/min.

To insert the oil into the lubricator unscrew the plug located on the upper surface or disassemble the bowl making sure that there is no pressure in the system. To regulate the oil into the circuit act with a screwdriver on the needle and adjust 1 oil drop every 300/600 NI/min.



Para desmontar la taza utilizamos una llave de compás. La taza transparente permite controlar el nivel de condensación en el filtro, o del aceite del lubricador.

To disassemble the bowl use a caliper face spanners. The transparent bowl permits the control of the condensate level in the filter and the oil level in the lubricator.

TOTO MINI

FILTRO / FILTER

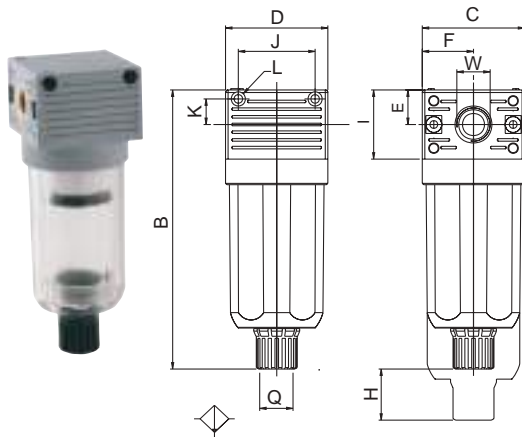

CÓDIGO DE LOS PRODUCTOS STANDARD EN STOCK - STANDARD PRODUCTS AVAILABLE IN STOCK

Código Code	Tamaño Size	Rosca Thread	Filtración Filtration	Caudal Flow Rate
T010002201000	FIL 0	1/8	20 µm	800 NI/min
T010003201000	FIL 0	1/4	20 µm	800 NI/min

Dimensiones - Dimensions

B	C	D	E	F	H	I	J	K	L	W	Q
109	40	40	13.5	20	11	27	30	10	Ø X M3	1/8 - 1/4	1/8

Codificación artículos para su demanda - Article codes to be used for ordering

T 0 1 0 0 0 3 2 0 1 0 0 0

Rosca / Thread:
02= G1/8
03= G1/4

Grado de Filtración:
Filtration Grade:
1= 5µm
2= 20µm
3= 50µm

Tipología de purga de condensados:
Condensate exhaust System
1= Semiautomático
Manual / Semiautomat Manual

Características Técnicas - Technical Characteristics

FLUIDO / FLUID
CONEXIÓN ROSCADA / THREADED FASTENING
GRADO DE FILTRACIÓN / FILTRATION GRADE
CAUDAL A 6 BAR CON Δp 1 bar
6 bar FLOW RATE WITH Δp 1 bar
PRESIÓN MAX / MAXIMUM PRESSURE
TEMPERATURA / TEMPERATURE
POSICIÓN DE MONTAJE / ASSEMBLY POSITION
CAPACIDAD TAZA / BOWL CAPACITY
PURGA DE CONDENSADOS / CONDENSATE EXHAUST

AIRE COMPRIMIDO / COMPRESSED AIR
1/8" - 1/4"
5µm - 20µm STANDARD 50µm
800 NI/min
15 bar
-10 / 50°C
VERTICAL / VERTICAL
17.5 cm³
MANUAL - SEMIAUTOMÁTICO
MANUAL - SEMI AUTOMATIC

Especificaciones de material - Specifications

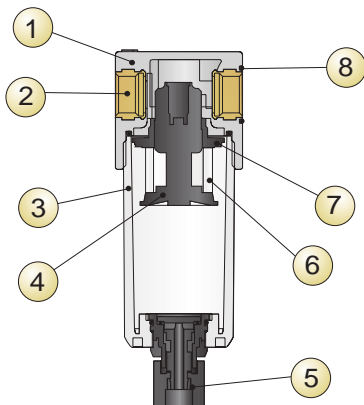

- 1 Cuerpo en tecnopolímero
- 2 Inserción roscada en latón
- 3 Taza en tecnopolímero
- 4 Portafiltro en tecnopolímero
- 5 Purga de condensados en tecnopolímero
- 6 Cartucho filtrante en PE
- 7 Centrifugador en tecnopolímero
- 8 Junta tórica en NBR

- 1 Technopolymeric Body
- 2 Brass Threaded insert
- 3 Technopolymeric Bowl
- 4 Technopolymeric Filter ring
- 5 Technopolymeric Condensate exhaust
- 6 PE Filtering cartridge
- 7 Technopolymeric Slinger
- 8 NBR O-Ring

T015 Mini Filtro Coalescente / Coalescer Filter

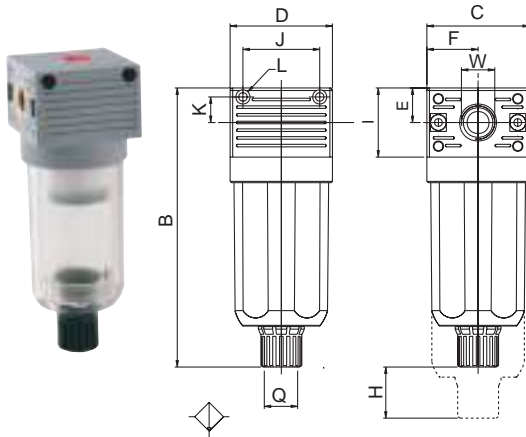

CÓDIGO DE LOS PRODUCTOS STANDARD EN STOCK- STANDARD PRODUCTS AVAILABLE IN STOCK

Código Code	Tamaño Size	Rosca Thread	Filtración Filtration	Caudal Flow Rate
T015002401000	FC 0	1/8	0.01 µm	450 NI/min
T015003401000	FC 0	1/4	0.01 µm	450 NI/min

Dimensiones - Dimensions

B	C	D	E	F	H	I	J	K	L	W	Q
109	40	40	13.5	20	11	27	30	10	Ø X M3	1/8 - 1/4	1/8

NB: CON EL FILTRO COALESCENTE T015 ACONSEJAMOS MONTAR UN FILTRO DE 5 µm
 NB: WITH COALESCER FILTER T015 WE RECOMMEND TO INSTALL A 5 µm FILTER UPSTREAM.

Codificación artículos para su demanda - Article codes to be used for ordering

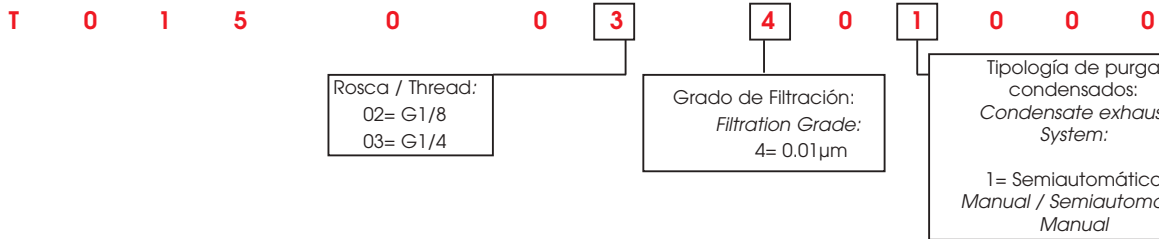

Características Técnicas - Technical Characteristics

FLUIDO / FLUID	AIRE COMPRIMIDO FILTRADO A 5 µm / 5 µm FILTRED COMPRESSED AIR
CONEXIÓN ROSCADA / THREADED FASTENING	1/8" - 1/4"
GRADO DE FILTRACIÓN / FILTRATION GRADE	0.01µm
CAUDAL A 6 BAR CON Δp 1 bar 6 bar FLOW RATE WITH Δp 1 bar	450 NI/min
PRESIÓN MAX / MAXIMUM PRESSURE	15 bar
TEMPERATURA / TEMPERATURE	-10 / 50°C
POSICIÓN DE MONTAJE / ASSEMBLY POSITION	VERTICAL / VERTICAL
CAPACIDAD TAZA / BOWL CAPACITY	17.5 cm ³
PURGA DE CONDENSADOS / CONDENSATE EXHAUST	MANUAL - SEMIAUTOMÁTICO MANUAL - SEMI AUTOMATIC

Especificaciones de material - Specifications

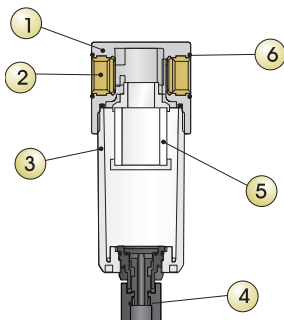

- | | |
|---|--------------------------------------|
| 1 Cuerpo en tecnopolímero | 1 Technopolymeric Body |
| 2 Inserción roscada en latón | 2 Brass Threaded Insert |
| 3 Taza en tecnopolímero | 3 Technopolymeric Bowl |
| 4 Purga de condensados en tecnopolímero | 4 Technopolymeric Condensate exhaust |
| 5 Cartucho Coalescente | 5 Coalescer cartridge |
| 6 Junta tórica en NBR | 6 NBR O-Ring |

Información - Informations

El cartucho coalescente está constituido de una capa de microfibras apoyado por una estructura externa de acero inox.
 El cartucho coalescente, utiliza los principios del impacto inercial, de la interceptación y la coalescencia, obliga a las partículas de líquido que lo atraviesan a unirse formando microgotas más grandes que, por gravedad precipitan en el fondo de la taza.
 El filtro coalescente utilizado como desoleador permite obtener un aire en la salida exento de aceite.
 Se aconseja de montar previamente al filtro coalescente un filtro de 5 µm que retenga las partículas sólidas evitando así la obturación del cartucho coalescente.
 Coalescer cartridge is made of microfiber layer with external stainless steel structure. Coalescing cartridge uses inertial impact, interception and coalescence to gather liquid particles into drops. These drops will fall into bowl bottom.
 Coalescing Filter is used as Oil Separator which removes oil-vapours from air output. We recommend to install a 5 µm Filter upstream to protect coalescing filter from choking of cartridge.

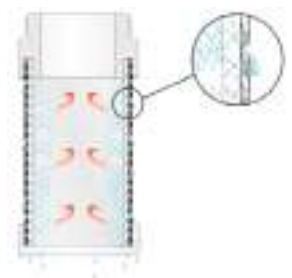

T020 Mini

Regulador / Regulator

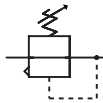
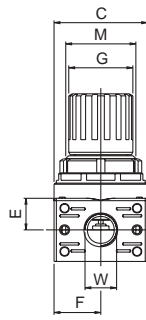
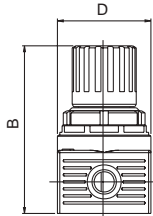

CÓDIGO DE LOS PRODUCTOS STANDARD EN STOCK - STANDARD PRODUCTS AVAILABLE IN STOCK

Código Code	Tamaño Size	Rosca Thread	Regulación Regulation	Caudal Flow Rate
T020002030000	REG 0	1/8	0 - 8 bar	600 NI/min
T020003030000	REG 0	1/4	0 - 8 bar	600 NI/min

Dimensiones - Dimensions

B	C	D	E	F	G	I	M	W
74	40	40	13.5	20	27.5	27	M30X1.5	1/8 - 1/4

Codificación artículos para su demanda - Article codes to be used for ordering

T 0 2 0 0 0 0 3 0 3 0 0 0 0

Rosca / Thread:
02= G1/8
03= G1/4

Campo de Regulación:
Regulation Range:
1= 0-2 bar
2= 0-4 bar
3= 0-8 bar
4= 0-12 bar

Características Técnicas - Technical Characteristics

FLUIDO / FLUID

AIRE COMPRIMIDO / COMPRESSED AIR

CONEXIÓN ROSCADA / THREADED FASTENING

1/8" - 1/4"

CAMPO DE REGULACIÓN / REGULATION RANGE

0-2 bar 0-4 bar 0-8 bar STANDARD 0-12 bar

CAUDAL A 6 BAR CON Δp 1 bar

600 NI/min

6 bar FLOW RATE WITH Δp 1 bar

PRESIÓN MAX / MAXIMUM PRESSURE

15 bar

TEMPERATURA / TEMPERATURE

-10 / 50°C

POSICIÓN DE MONTAJE / ASSEMBLY POSITION

VERTICAL / VERTICAL

CONEXIÓN MANÓMETRO / MANOMETER FASTENING

G 1/8

Especificaciones de material - Specifications

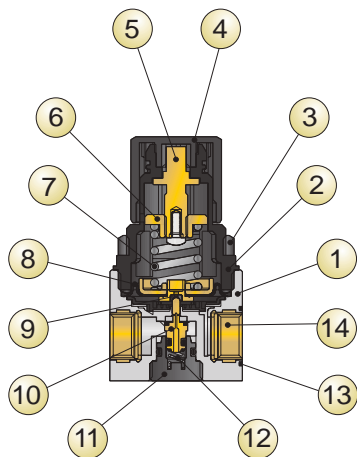

- 1 Cuerpo en tecnopolímero
- 2 Campana en tecnopolímero
- 3 Tuerca de fijación en tecnopolímero
- 4 Pomo en tecnopolímero
- 5 Tornillo de registro en latón
- 6 Tuerca hembra en latón
- 7 Muelle de registro en acero
- 8 Membrana
- 9 Junta relieving en NBR
- 10 Obturador con junta vulcanizada en NBR
- 11 Tapón en tecnopolímero
- 12 Muelle obturador en acero inox
- 13 Junta tórica en NBR
- 14 Inserción roscada en latón

- 1 Technopolymeric Body
- 2 Technopolymeric Bell
- 3 Technopolymeric Fixing nut
- 4 Technopolymeric Knob
- 5 Brass Register screw
- 6 Brass Female screw
- 7 Steel Register spring
- 8 Membrane Rolling
- 9 NBR Relieving diaphragm
- 10 Shutter with NBR vulcanized seal
- 11 Technopolymeric Plug
- 12 Stainless steel Push-shutter spring
- 13 NBR O-Ring
- 14 Brass Threaded insert

T070 Mini

Regulador Escape Rápido Quick Exhaust Regulator

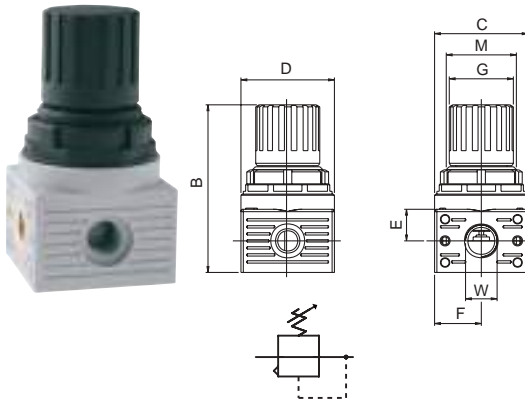

CÓDIGO DE LOS PRODUCTOS STANDARD EN STOCK - STANDARD PRODUCTS AVAILABLE IN STOCK

Código Code	Tamaño Size	Rosca Thread	Regulación Regulation	Caudal Flow Rate
T070002030000	REG.S.RAP. 0	1/8	0 - 8 bar	600 NI/min
T070003030000	REG.S.RAP. 0	1/4	0 - 8 bar	600 NI/min

Dimensiones - Dimensions

B	C	D	E	F	G	I	M	W
74	40	40	13.5	20	27.5	27	M30X1.5	1/8 - 1/4

Codificación artículos para su demanda - Article codes to be used for ordering

T 0 7 0 0 0 3 0 3 0 0 0 0

Rosca / Thread:
02= G1/8
03= G1/4

Campo de Regulación:
Regulation Range:
1= 0-2 bar
2= 0-4 bar
3= 0-8 bar
4= 0-12 bar

Características Técnicas - Technical Characteristics

FLUIDO / FLUID	AIRE COMPRIMIDO / COMPRESSED AIR
CONEXIÓN ROSCADA / THREADED FASTENING	1/8" -1/4"
CAMPO DE REGULACIÓN / REGULATION RANGE	0-2 bar 0-4 bar 0-8 bar STANDARD 0-12 bar
CAUDAL A 6 BAR CON Δp 1 bar 6 bar FLOW RATE WITH Δp 1 bar	600 NI/min
PRESIÓN MAX / MAXIMUM PRESSURE	15 bar
TEMPERATURA / TEMPERATURE	-10 / 50°C
POSICIÓN DE MONTAJE / ASSEMBLY POSITION	VERTICAL / VERTICAL
CONEXIÓN MANÓMETRO / MANOMETER FASTENING	G 1/8

Especificaciones de material - Specifications

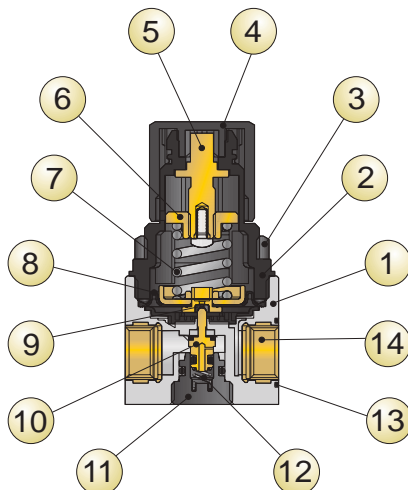

- | | |
|---|--|
| 1 Cuerpo en tecnopolímero | 1 Technopolymeric Body |
| 2 Campana en tecnopolímero | 2 Technopolymeric Bell |
| 3 Tuerca de fijación en tecnopolímero | 3 Technopolymeric Fixing nut |
| 4 Pomo en tecnopolímero | 4 Technopolymeric Knob |
| 5 Tornillo de registro en latón | 5 Brass Register screw |
| 6 Tuerca hembra en latón | 6 Brass Female screw |
| 7 Muelle de registro en acero | 7 Steel Register spring |
| 8 Membrana | 8 Rolling membrane |
| 9 Junta relieving en NBR | 9 NBR Relieving diaphragm |
| 10 Obturador con junta vulcanizada en NBR | 10 Shutter with NBR vulcanized seal |
| 11 Tapón en tecnopolímero | 11 Technopolymeric Plug |
| 12 Muelle obturador en acero inox | 12 Stainless steel Push-shutter spring |
| 13 Junta tórica en NBR | 13 NBR O-Ring |
| 14 Inserción roscada en latón | 14 Brass Threaded insert |

T080 Mini

Regulador para Agua Water Regulator

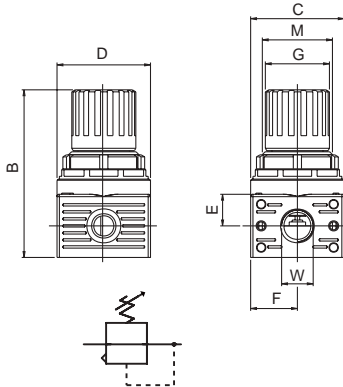

CÓDIGO DE LOS PRODUCTOS STANDARD EN STOCK - STANDARD PRODUCTS AVAILABLE IN STOCK

Código Code	Tamaño Size	Rosca Thread	Regulación Regulation
T080002030000	REG.AGUA 0	1/8	0 - 8 bar
T080003030000	REG.AGUA 0	1/4	0 - 8 bar

Dimensiones - Dimensions

B	C	D	E	F	G	I	M	W
74	40	40	13.5	20	27.5	27	M30X1.5	1/8 - 1/4

Codificación artículos para su demanda - Article codes to be used for ordering

T 0 8 0 0 0 0 3 0 3 0 0 0 0

Rosca / Thread:
02= G1/8
03= G1/4

Campo de Regulación:
Regulation Range:
1= 0-2 bar
2= 0-4 bar
3= 0-8 bar
4= 0-12 bar

Características Técnicas - Technical Characteristics

FLUIDO / FLUID

CONEXIÓN ROSCADA / THREADED FASTENING

CAMPO DE REGULACIÓN / REGULATION RANGE

PRESIÓN MAX / MAXIMUM PRESSURE

TEMPERATURA / TEMPERATURE

POSICIÓN DE MONTAJE / ASSEMBLY POSITION

CONEXIÓN MANÓMETRO / MANOMETER FASTENING

AGUA / WATER

1/8" -1/4"

0-2 bar 0-4 bar 0-8 bar STANDARD 0-12 bar

15 bar

5° / 50°C

VERTICAL / VERTICAL

G 1/8

Especificaciones de material - Specifications

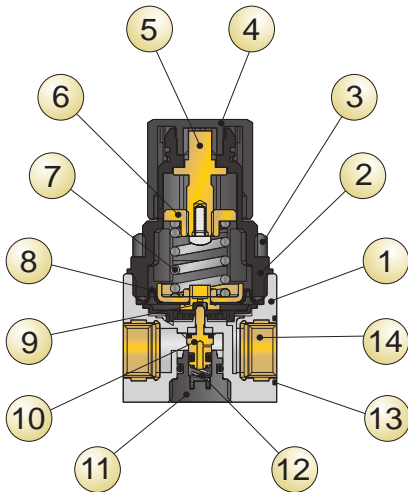

- 1 Cuerpo en tecnopolímero
- 2 Campana en tecnopolímero
- 3 Tuerca de fijación en tecnopolímero
- 4 Pomo en tecnopolímero
- 5 Tornillo de registro en latón
- 6 Tuerca hembra en latón
- 7 Muelle de registro en acero
- 8 Membrana
- 9 Junta relieving en NBR
- 10 Obturador con junta vulcanizada en NBR
- 11 Tapón en tecnopolímero
- 12 Muelle obturador en acero inox
- 13 Junta tórica en NBR
- 14 Inserción roscada en latón

- 1 Technopolymeric Body
- 2 Technopolymeric Bell
- 3 Technopolymeric Fixing nut
- 4 Technopolymeric Knob
- 5 Brass Register screw
- 6 Brass Female screw
- 7 Steel Register spring
- 8 Rolling membrane
- 9 NBR Relieving diaphragm
- 10 Shutter with NBR vulcanized seal
- 11 Technopolymeric Plug
- 12 Stainless steel Push-shutter spring
- 13 NBR O-Ring
- 14 Brass Threaded insert

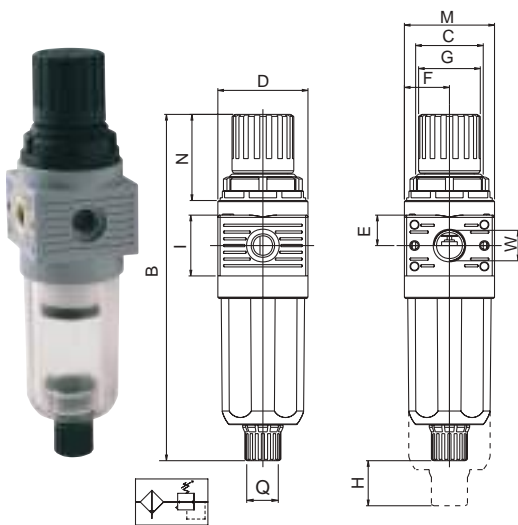
T030 Mini
Filtroregulador / Filter Regulator

CÓDIGO DE LOS PRODUCTOS STANDARD EN STOCK - STANDARD PRODUCTS AVAILABLE IN STOCK

Código Code	Tamaño Size	Rosca Thread	Filtración Filtration	Regulación Regulation	Caudal Flow Rate
T030002231000	FR 0	1/8	20µm	0 - 8 bar	600 NI/min
T030003231000	FR 0	1/4	20µm	0 - 8 bar	600 NI/min

Dimensiones - Dimensions

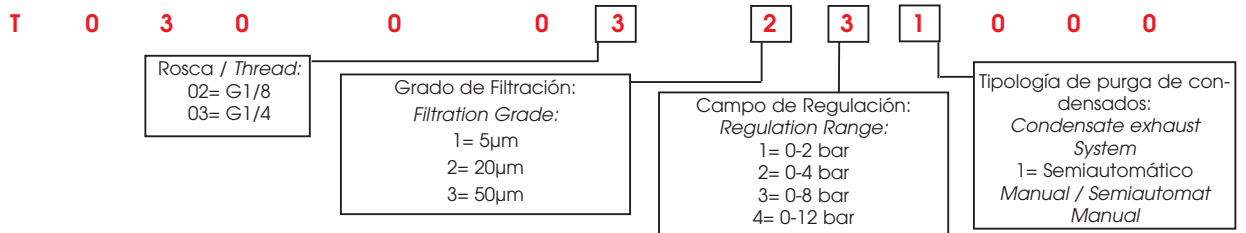
B	C	D	E	F	G	H	I	M	N	W
156	40	40	13.5	20	27.5	11	27	M30X1.5	40	1/8 - 1/4

Codificación artículos para su demanda - Article codes to be used for ordering

Características Técnicas - Technical Characteristics

FLUIDO / FLUID

CONEXIÓN ROSCADA / THREADED FASTENING

CAMPO DE REGULACIÓN / REGULATION RANGE

GRADO DE FILTRACIÓN / FILTRATION GRADE

CAUDAL A 6 BAR CON Δp 1 bar

6 bar FLOW RATE WITH Δp 1 bar

PRESIÓN MAX / MAXIMUM PRESSURE

TEMPERATURA / TEMPERATURE

POSICIÓN DE MONTAJE / ASSEMBLY POSITION

CAPACIDAD TAZA / BOWL CAPACITY

PURGA DE CONDENSADOS / CONDENSATE EXHAUST

CONEXIÓN MANÓMETRO / MANOMETER FASTENING

AIRE COMPRIMIDO / COMPRESSED AIR

1/8" - 1/4"

0-2 bar 0-4 bar 0-8 bar STANDARD 0-12 bar

5µm - 20µm STANDARD - 50µm

600 NI/min

15 bar

-10 / 50°C

VERTICAL / VERTICAL

 17.5 cm³

MANUAL- SEMIAUTOMÁTICO / MANUAL- SEMI AUTOMATIC

G 1/8

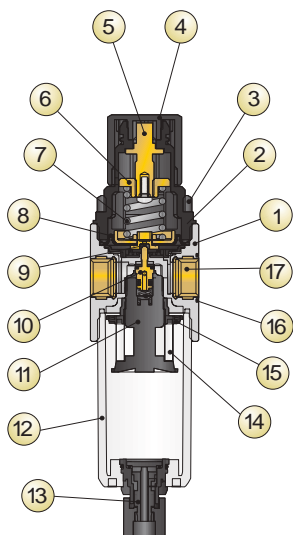
Especificaciones de material - Specifications

- 1 Cuerpo en tecnopolímero
- 2 Campana en tecnopolímero
- 3 Tuerca de fijación en tecnopolímero
- 4 Pomo en tecnopolímero
- 5 Tornillo de registro en latón
- 6 Tuerca hembra en latón
- 7 Muelle de registro en acero
- 8 Membrana
- 9 Junta relieving en NBR
- 10 Obturador con junta vulcanizada en NBR
- 11 Portafiltro en tecnopolímero
- 12 Taza en tecnopolímero
- 13 Purga de condensados en tecnopolímero
- 14 Cartucho filtrante en PE
- 15 Centrifugador en tecnopolímero
- 16 Junta tórica en NBR
- 17 Inserción roscada en latón

- 1 Technopolymeric Body
- 2 Technopolymeric Bell
- 3 Technopolymeric Fixing nut
- 4 Technopolymeric Knob
- 5 Brass Register screw
- 6 Brass Female screw
- 7 Register spring made in steel
- 8 Rolling membrane
- 9 NBR Relieving diaphragm
- 10 Shutter with NBR vulcanized seal
- 11 Technopolymeric Filter ring
- 12 Technopolymeric Bowl
- 13 Technopolymeric Condensate exhaust
- 14 PE Filtering cartridge
- 15 Technopolymeric Slinger
- 16 NBR O-Ring
- 17 Brass Threaded insert

T040 Mini

Lubricador / Lubricator

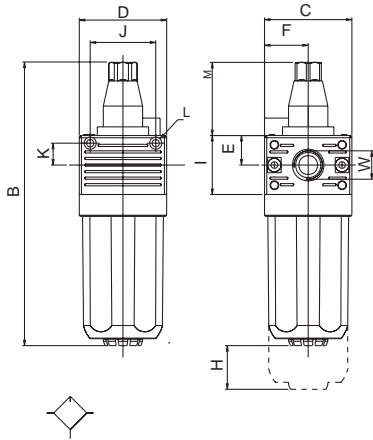

CÓDIGO DE LOS PRODUCTOS STANDARD EN STOCK- STANDARD PRODUCTS AVAILABLE IN STOCK

Código Code	Tamaño Size	Rosca Thread	Caudal Flow Rate
T040002000100	LUB 0	1/8	700 NI/min
T040003000100	LUB 0	1/4	700 NI/min

Dimensiones - Dimensions

B	C	D	E	F	H	I	J	K	L	M	W
130	40	40	13.5	20	11	27	30	10	Ø X M3	33.5	1/8 - 1/4

Codificación artículos para su demanda - Article codes to be used for ordering

T 0 4 0 0 0 2 0 0 0 1 0 0

Rosca / Thread:
02= G1/8
03= G1/4

Tipología de
carga de aceite:
Oil load system:
1= Manual / Manual

Características Técnicas - Technical Characteristics

FLUIDO / FLUID

CONEXIÓN ROSCADA / THREADED FASTENING

CAUDAL A 6 BAR CON Δp 1 bar

6 bar FLOW RATE WITH Δp 1 bar

PRESIÓN MAX / MAXIMUM PRESSURE

TEMPERATURA / TEMPERATURE

TORNILLOS DE FIJACIÓN / WALL CLAMPING SCREWS

POSICIÓN DE MONTAJE / ASSEMBLING POSITION

CAPACIDAD TAZA / BOWL CAPACITY

ACEITE ACONSEJADO / RECOMMENDED OILS

AIRE COMPRIMIDO / COMPRESSED AIR

1/8" -1/4"

700 NI/min

15 bar

-10 / 50°C

M3

VERTICAL / VERTICAL

28 cm3

CLASE ISO VG 22A NORMA ISO 3448

ISO VG 22A CLASS ISO 3448 NORMA

Especificaciones de material - Specifications

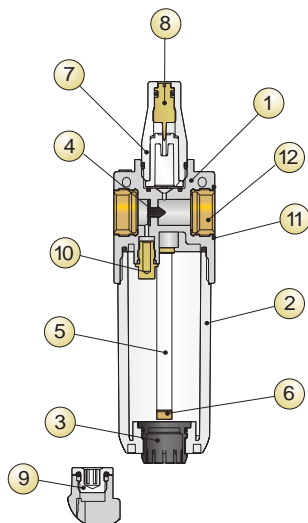

- 1 Cuerpo en tecnopolímero
- 2 Taza en tecnopolímero
- 3 Tapón en tecnopolímero
- 4 Membrana dispositivo Venturi
- 5 Tubo aspiración aceite en PA11
- 6 Filtro pequeño
- 7 Cúpula visor en tecnopolímero transparente
- 8 Tornillo de regulación caudal de aceite en latón
- 9 Tapón carga aceite en latón
- 10 Difusor aire en latón
- 11 Junta tórica en NBR
- 12 Inserción roscada en latón

- 1 Technopolymeric Body
- 2 Technopolymeric Bowl
- 3 Technopolymeric Plug
- 4 Membrane Venturi device
- 5 Oil aspiration tube made in PA11
- 6 Small filter
- 7 Transparent technopolymeric Visual dome
- 8 Brass Oil regulating capacity pin
- 9 Brass Oil loading plug
- 10 Brass Air diffuser
- 11 NBR O-Ring
- 12 Brass Threaded insert

T100 Mini

FR + L

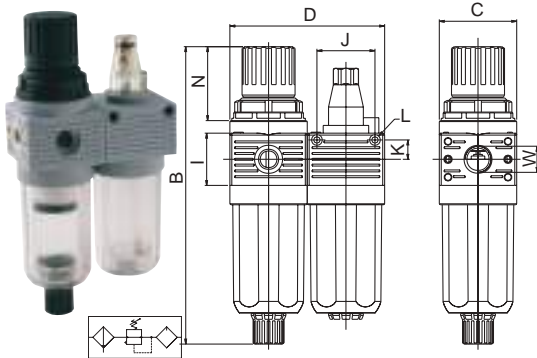
CÓDIGO DE LOS PRODUCTOS STANDARD EN STOCK-STANDARD PRODUCTS AVAILABLE IN STOCK

Código Code	Tamaño Size	Rosca Thread	Filtración Filtration	Regulación Regulation	Caudal Flow Rate
T100002231 100	FR+L 0	1/8	20µm	0-8 bar	260 NI/min
T100003231 100	FR+L 0	1/4	20µm	0-8 bar	260 NI/min

Dimensiones - Dimensions

B	C	D	I	J	K	L	N	W
156	40	80	27	30	10	Ø X M3	40	1/8 - 1/4

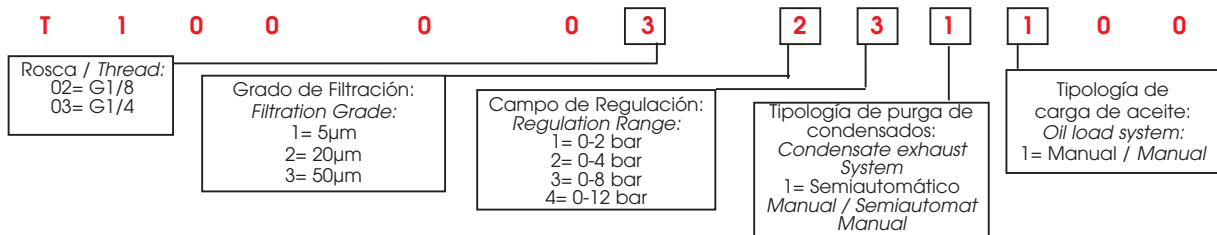
Codificación artículos para su demanda - Article codes to be used for ordering

Características Técnicas - Technical Characteristics

FLUIDO / FLUID CONEXIÓN ROSCADA / THREADED FASTENING GRADO DE FILTRACIÓN / FILTRATION GRADE CAMPO DE REGULACIÓN / REGULATION RANGE CAUDAL A 6 BAR CON Δp 1 bar 6 bar FLOW RATE WITH Δp 1 bar PRESIÓN MAX / MAXIMUM PRESSURE TEMPERATURA / TEMPERATURE TORNILLOS DE FIJACIÓN / WALL CLAMPING SCREWS POSICIÓN DE MONTAJE / ASSEMBLING POSITION ACEITE ACONSEJADO / RECOMMENDED OILS	AIRE COMPRIMIDO / COMPRESSED AIR 1/8" -1/4" 5µm - 20µm STANDARD - 50µm 0-2 bar 0-4 bar 0-8 bar STANDARD 0-12 bar 260 NI/min 15 bar -10 / 50°C M3 VERTICAL / VERTICAL CLASE ISO VG 22A NORMA ISO 3448
---	---

T200 Mini

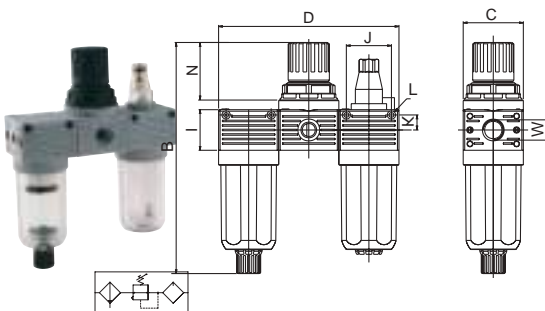
F + R + L

CÓDIGO DE LOS PRODUCTOS STANDARD EN STOCK-STANDARD PRODUCTS AVAILABLE IN STOCK

Código Code	Tamaño Size	Rosca Thread	Filtración Filtration	Regulación Regulation	Caudal Flow Rate
T200002231 100	F+R+L 0	1/8	20µm	0-8 bar	280 NI/min
T200003231 100	F+R+L 0	1/4	20µm	0-8 bar	280 NI/min

Dimensiones - Dimensions

B	C	D	I	J	K	L	N	W
156	40	120	27	30	10	Ø X M3	40	1/8 - 1/4

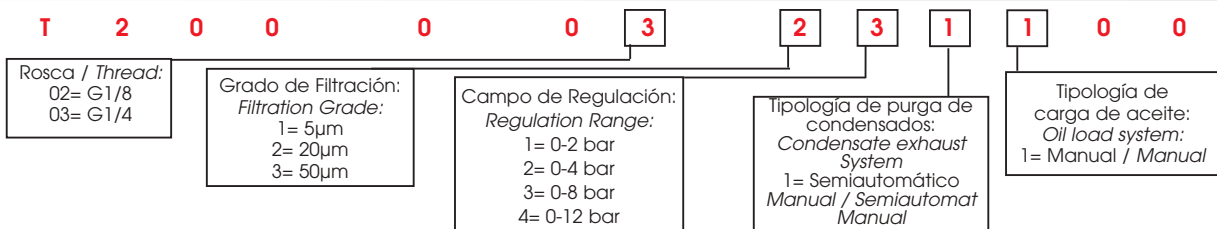
Codificación artículos para su demanda / Article codes to be used for ordering

Características Técnicas - Technical Characteristics

FLUIDO / FLUID CONEXIÓN ROSCADA / THREADED FASTENING GRADO DE FILTRACIÓN / FILTRATION GRADE CAMPO DE REGULACIÓN / REGULATION RANGE CAUDAL A 6 BAR CON Δp 1 bar 6 bar FLOW RATE WITH Δp 1 bar PRESIÓN MAX / MAXIMUM PRESSURE TEMPERATURA / TEMPERATURE TORNILLOS DE FIJACIÓN / WALL CLAMPING SCREWS POSICIÓN DE MONTAJE / ASSEMBLING POSITION ACEITE ACONSEJADO / RECOMMENDED OILS	AIRE COMPRIMIDO / COMPRESSED AIR 1/8" -1/4" 5µm - 20µm STANDARD - 50µm 0-2 bar 0-4 bar 0-8 bar STANDARD 0-12 bar 280 NI/min 15 bar -10 / 50°C M3 VERTICAL / VERTICAL CLASE ISO VG 22A NORMA ISO 3448
---	---

T400 Mini

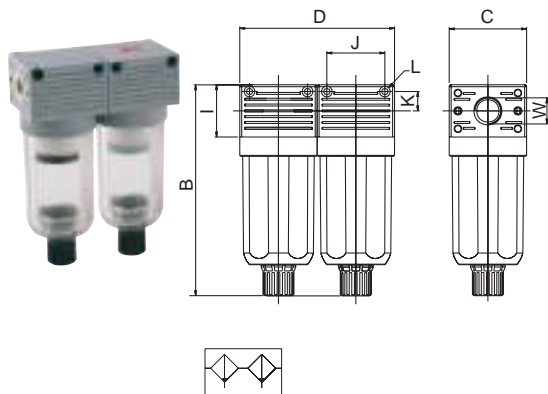
FIL + FC



CÓDIGO DE LOS PRODUCTOS STANDARD EN STOCK - STANDARD PRODUCTS AVAILABLE IN STOCK

Código Code	Tamaño Size	Rosca Thread	Filtración Filtration	Caudal Flow Rate
T40002401000	FIL+FC 0	1/8	5µm + 0.01µm	370 NI/min
T40003401000	FIL+FC 0	1/4	5µm + 0.01µm	370 NI/min

Dimensiones - Dimensions

B	C	D	I	J	K	L	W
109	40	80	27	30	10	Ø X M3	1/8 - 1/4

Codificación artículos para su demanda - Article codes to be used for ordering

T 4 0 0 0 0 3 4 0 1 0 0 0

Rosca / Thread:
02= G1/8
03= G1/4

Grado de Filtración:
Filtration Grade:
4= 0.01µm

Tipología de purga de condensados:
Condensate exhaust System:

1= Semiautomático
Manual / Semiautomatic
Manual

Características Técnicas - Technical Characteristics

FLUIDO / FLUID
CONEXIÓN ROSCADA / THREADED FASTENING
GRADO DE FILTRACIÓN / FILTRATION GRADE
CAUDAL A 6 BAR CON Δp 1 bar
6 bar FLOW RATE WITH Δp 1 bar
PRESIÓN MAX / MAXIMUM PRESSURE
TEMPERATURA / TEMPERATURE
TORNILLOS DE FIJACIÓN / WALL CLAMPING SCREWS
POSICIÓN DE MONTAJE / ASSEMBLING POSITION

AIRE COMPRIMIDO / COMPRESSED AIR
1/8" -1/4"
5µm + 0.01µm
370 NI/min

15 bar
-10 / 50°C
M3
VERTICAL / VERTICAL

Información - Informations

CARTUCHO COALESCENTE
COALESCER CARTRIDGE

MICROFIBRAS CRUZADAS
INTERLACED MICROFIBERS

El cartucho coalescente está constituido de una capa de microfibras apoyada por una estructura externa de acero inox.
El cartucho coalescente, utiliza los principios del impacto inercial, de la interceptación y la coalescencia, obliga a las partículas de líquido que lo atraviesan a unirse formando microgotas más grandes que, por gravedad precipitan en el fondo de la taza.
El filtro coalescente utilizado como desoleador permite obtener un aire en la salida exento de aceite.
Se aconseja de montar previamente al filtro coalescente un filtro de 5 µm que retenga las partículas sólidas evitando así la obturación del cartucho coalescente.

Coalescer cartridge is made of microfiber layer with external stainless steel structure. Coalescing cartridge uses inertial impact, interception and coalescence to gather liquid particles into drops. These drops will fall into bowl bottom.
Coalescing Filter is used as Oil Separator which removes oil-vapours from air output. We recommend to install a 5 µm Filter upstream to protect coalescing filter from choking of cartridge.

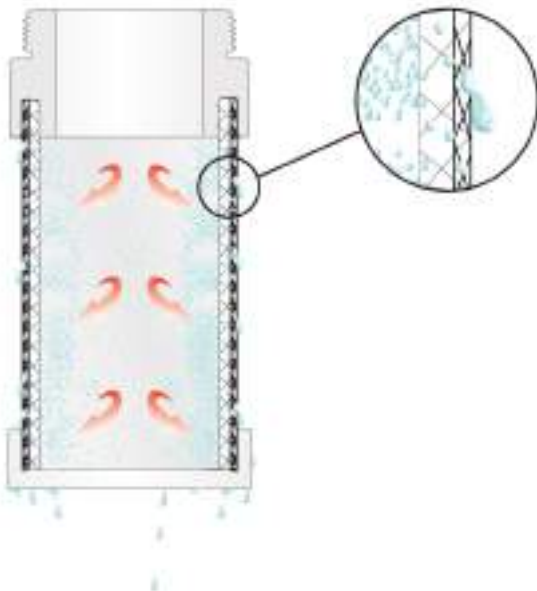

T450 Mini

FR + FC

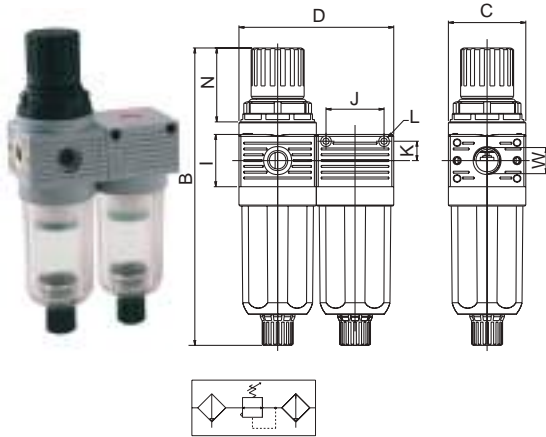

CÓDIGO DE LOS PRODUCTOS STANDARD EN STOCK - STANDARD PRODUCTS AVAILABLE IN STOCK

Código Code	Tamaño Size	Rosca Thread	Regulación Regulation	Filtración Filtration	Caudal Flow Rate
T450002431000	FR+FC 0	1/8	0 - 8 bar	5µm + 0.01µm	370 NI/min
T450003431000	FR+FC 0	1/4	0 - 8 bar	5µm + 0.01µm	370 NI/min

Dimensiones - Dimensions

B	C	D	I	J	K	L	N	W
156	40	80	27	30	10	Ø X M3	40	1/8 - 1/4

Codificación artículos para su demanda - Article codes to be used for ordering

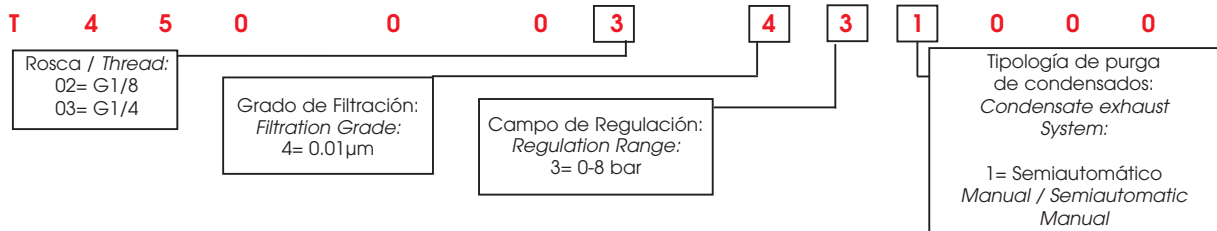

Características Técnicas - Technical Characteristics

FLUIDO / FLUID
 CONEXIÓN ROSCADA / THREADED FASTENING
 GRADO DE FILTRACIÓN / FILTRATION GRADE
 CAMPO DE REGULACIÓN / REGULATION RANGE
 CAUDAL A 6 BAR CON Δp 1 bar
 6 bar FLOW RATE WITH Δp 1 bar
 PRESIÓN MAX / MAXIMUM PRESSURE
 TEMPERATURA / TEMPERATURE
 TORNILLOS DE FIJACIÓN / WALL CLAMPING SCREWS
 POSICIÓN DE MONTAJE / ASSEMBLING POSITION

AIRE COMPRIMIDO / COMPRESSED AIR
 1/8" - 1/4"
 5µm + 0.01µm
 0-8 bar
 370 NI/min
 15 bar
 -10 / 50°C
 M3
 VERTICAL / VERTICAL

Información - Informations

CARTUCHO COALESCENTE
 COALESCER CARTRIDGE

MICROFIBRAS CRUZADAS
 INTERLACED MICROFIBERS

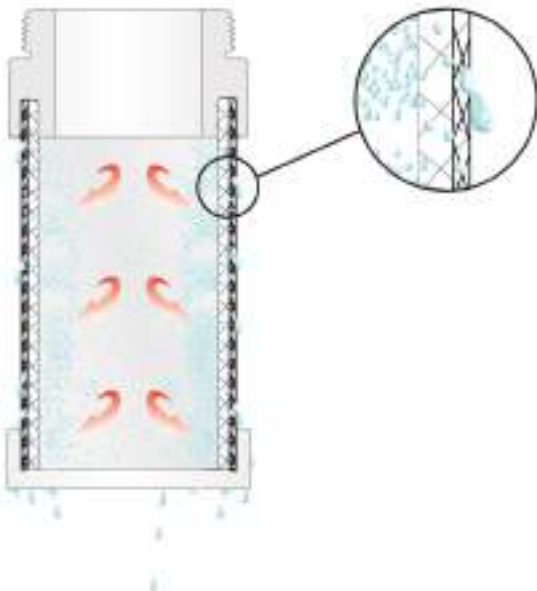

El cartucho coalescente está constituido de una capa de microfibras apoyada por una estructura externa de acero inox.
 El cartucho coalescente, utiliza los principios del impacto inercial, de la interceptación y la coalescencia, obliga a las partículas de líquido que lo atraviesan a unirse formando microgotas más grandes que, por gravedad precipitan en el fondo de la taza.
 El filtro coalescente utilizado como desoleador permite obtener un aire en la salida exento de aceite.
 Se aconseja de montar previamente al filtro coalescente un filtro de 5 µm que retenga las partículas sólidas evitando así la obturación del cartucho coalescente.

Coalescer cartridge is made of microfiber layer with external stainless steel structure. Coalescing cartridge uses inertial impact, interception and coalescence to gather liquid particles into drops. These drops will fall into bowl bottom.
 Coalescing Filter is used as Oil Separator which removes oil-vapours from air output. We recommend to install a 5 µm Filter upstream to protect coalescing filter from choking of cartridge.

Instrucciones Técnicas Frl 1-2-3 / Technical Instruction Frl 1-2-3

El ensamblaje de los componentes de la serie FRL, debe de seguir en líneas generales, el siguiente orden: Válvula de corte V3V, Filtro, Regulador, Lubricador y Válvula de arranque progresivo. La conexión de los componentes se debe de hacer de modo que el aire fluya en la misma dirección que viene indicado en las flechas puestas en la parte superior de los componentes.

The setting up of the parts has to be done as follows: Put the plates in the proper places of the bodies. Put the assembling parts together, making sure that the o-ring are in their proper seats. Tighten the screws on the plates.

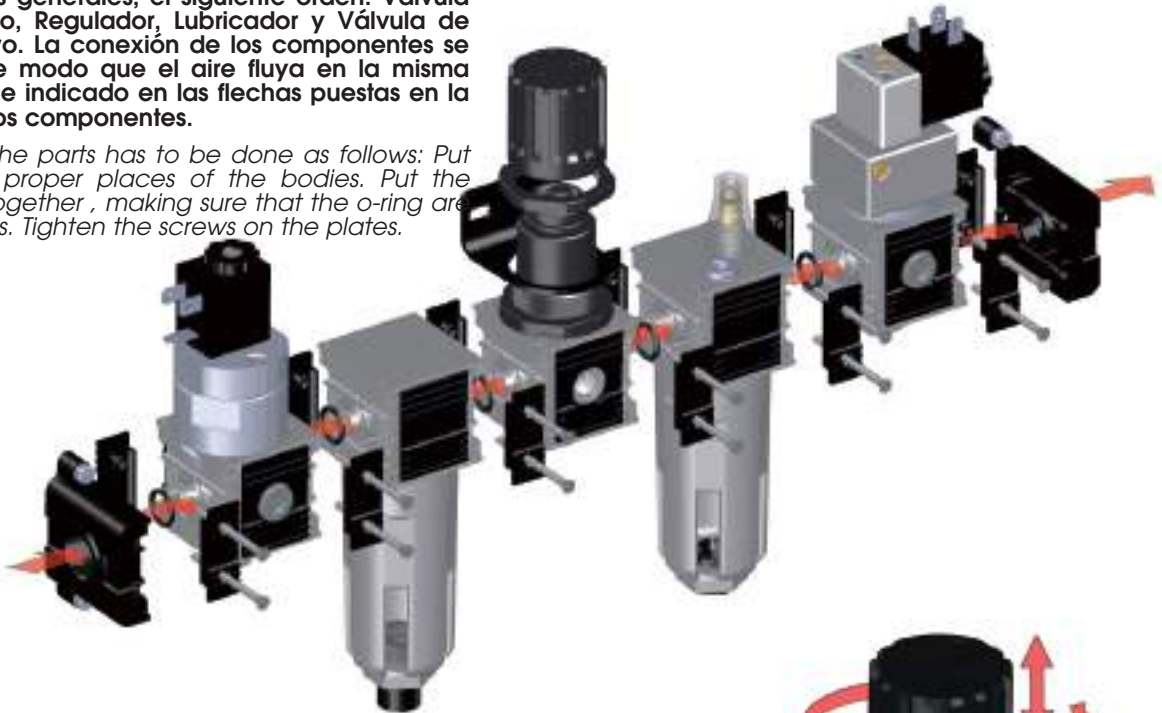

Para regular la presión se debe de seguir estas indicaciones:

- Tirar del pomo hasta llegar a la posición de regulación.
- Fijar la presión deseada para la salida girando el pomo.
- Presionar el pomo hasta la posición de bloqueo.

La colocación del manómetro debe realizarse manualmente y aplicando líquido sellante.

To regulate the pressure follow these suggestions:

- raise the knob to the regulating position;
- fix up the required pressure always upgrade then press the knob to the block position.

The manometer has to be assembled manually with the addition of liquid sealant.



Para iniciar el funcionamiento de la válvula de corte V3V hay que seguir los siguientes pasos: Presionando el pulsador de accionamiento 1 se abre el circuito primario hacia la utilización, presionando el pulsador 2 se cierra el circuito primario y se comunica el escape con el secundario. Esta última operación se puede bloquear con un candado.

The driving of the shut off valve follows these steps: pressing the start push button 1 you open the primary circuit towards the use; pressing the push button 2 you close the primary circuit and put the secondary one in exhaust. A padlock can lock this last operation.



Para añadir aceite en el lubricador, abriremos el tapón colocado en la pared superior o desenroscando el vaso, asegurándose de que no haya presión en el circuito. La regulación del aceite en el circuito se efectúa utilizando un destornillador sobre el tornillo del tapón, ajustándolo a una gota cada 300/600NI/min.

To insert the oil into the lubricator, unscrew the plug on the upper surface or disassemble the bowl making sure that no pressure is in the system. To regulate the oil into the circuit act the needle with a screwdriver and adjust 1 oil drop every 300/600NI/min.

PUSHING START BUTTON
FOR PRIMING OF OIL



La carga de aceite por depresión consiente en el llenado automático de aceite en la taza. El sistema se activa mediante el accionamiento de un pulsador y el aceite recogido de un depósito situado incluso a una cota más baja que el lubricador fluye dentro de la taza gracias a un a rosca G 1/4 situada en el inferior. La carga debe ser interrumpida cuando el aceite alcanza el nivel máximo permitido correspondiente a la apertura transparente de la taza.

The priming of vacuum permits the automatic filling in the bowl. Pushing the start button starts the driving of the system. The oil, collected from a level lower than lubricator, flows into the bowl thanks to a fitting G located under the bowl. Stop the priming when the oil has reached the maximum level allowed. This level corresponds with the transparent windows in the bowl.

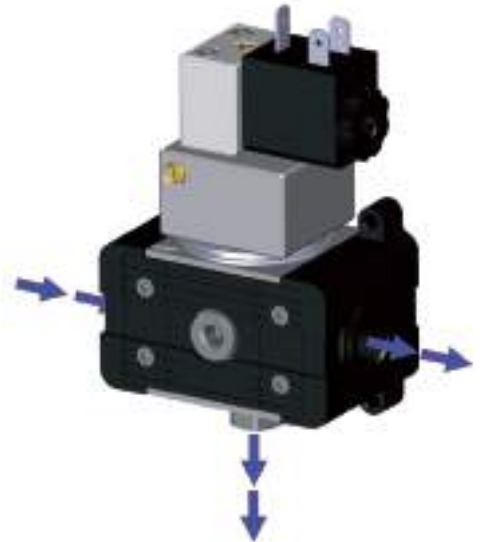

La válvula de arranque progresivo es un dispositivo neumático que permite la entrada de aire gradualmente y de un modo regulable en el circuito. El escape rápido es una función integrada en nuestra válvula, por consiguiente, es posible interrumpir el flujo de aire interrumpiendo la señal eléctrica de pilotaje, y descargando rápidamente el aire residual al ambiente externo. La regulación del tiempo para el incremento de la presión, viene registrada por un tornillo que interviene sobre la regulación del flujo. El comando de pilotaje es electroneumático: el inicio para activar la válvula de arranque progresivo es mediante un impulso eléctrico. La válvula con escape rápido va posicionada después de todos los componentes de tratamiento de aire comprimido.

The soft start valve is a pneumatic valve that permits to pressurize gradually and constantly the pneumatic systems. The quick exhaust is present on our soft starter; by switching off the electrical signal it stops the air-intake, exhusting the remaining air downstream. To regulate the pressure increasing time use a screw. An electrical impulse gives power to the starter. Install the starter on the system just after the components for air treatment.



El escape de la condensación, manual o semiautomática, se efectúa automáticamente cuando no hay presión en la taza, presionando la purga es posible hacer el escape de la condensación con presencia de presión, y girando la purga en sentido contrario a las agujas del reloj, el escape vuelve a posición cerrada.

The automatic/semiautomatic condensate exhaust is normally in the open position; i.e. it exhausts automatically the condensate when there is no pressure inside of the bowl. Pressing the knob it is possible to exhaust the condensate even if it is on pressure, turning the knob in anticlockwise sense the exhaust is in the close position.



El escape de condensación Automática está disponible para los tamaños FRL2 y FRL3. Su funcionamiento es de sistema boya, hace la descarga cuando la condensación llega a un nivel programado independientemente de la presión de trabajo.

The condensate exhaust is available for the sizes FRL2 and FRL3. It works as a float that exhausts the condensate when this reaches the programmed level without any relation to the pressure used.

FIJACIÓN STANDARD.
STANDARD FIXING.



FIJACIÓN CON DISTANCIALES.
FIXING WITH DISTANCE.

El elemento utilizado para la fijación del grupo de tratamiento de aire a la pared, puede desempeñar la función de distanciador: es suficiente girar el elemento. El distanciador permite fijar el grupo de tratamiento a una superficie que no esté perfectamente plana.

The part used to fix the FRL on the wall can be used as a distance spacer as well. It is enough to unscrew this part, turn it and screw it again. The distance spacer permits in this way the fixing of the treatment of compressed air on surfaces not properly smooth and flat.



Para desmontar la taza utilizar una llave hexagonal de tubo. La apertura transparente bajo la taza permite el control del nivel de condensación para el filtro, o el aceite para el lubricador.

To disassembly the bowl use an hexagon tube wrench. The bowl has got transparent windows which permit to check the lubricator oil level or the filter condensate level.

T010

Filtro / Filter



CÓDIGO DE LOS PRODUCTOS STANDARD EN STOCK - STANDARD PRODUCTS AVAILABLE IN STOCK

Código Code	Tamaño Size	Rosca Thread	Filtración Filtration	Caudal Flow Rate	Purga Exhaust
T010103201000	FIL 1	1/4	20 µm	1900 NI/min	S/M
T010104201000	FIL 1	3/8	20 µm	1900 NI/min	S/M
T010204201000	FIL 2	3/8	20 µm	3750 NI/min	S/M
T010205201000	FIL 2	1/2	20 µm	3750 NI/min	S/M
T010205202000	FIL 2	1/2	20 µm	3750 NI/min	A
T010307201000	FIL 3	3/4	20 µm	6250 NI/min	S/M
T010309201000	FIL 3	1"	20 µm	6250 NI/min	S/M
T010309202000	FIL 3	1"	20 µm	6250 NI/min	A

S/M: Semiautomático / Manual
Semi Automatic / Manual

A: Automático / Automatic

Codificación artículos para su demanda - Article codes to be used for ordering

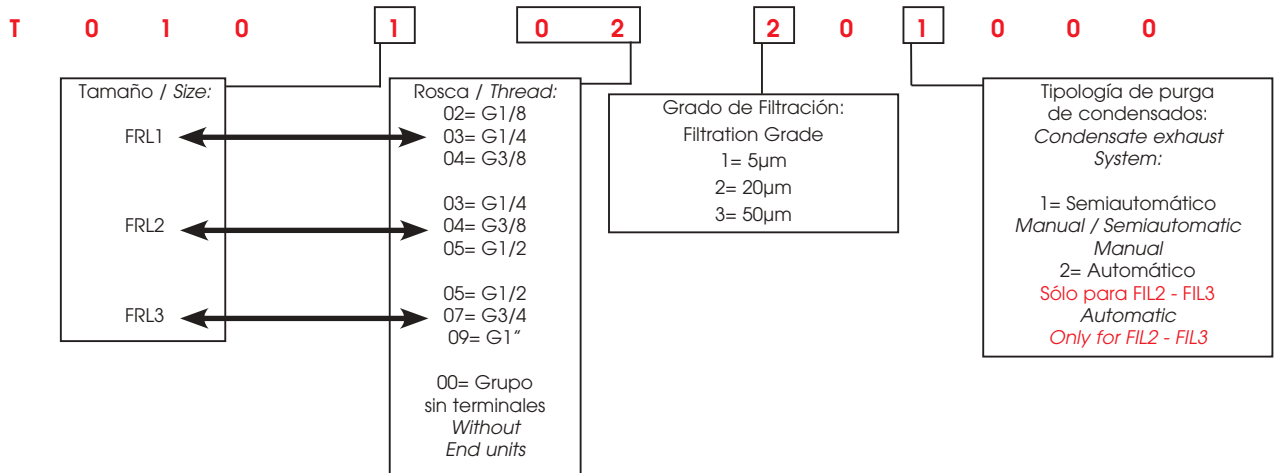

Dimensiones - Dimensions

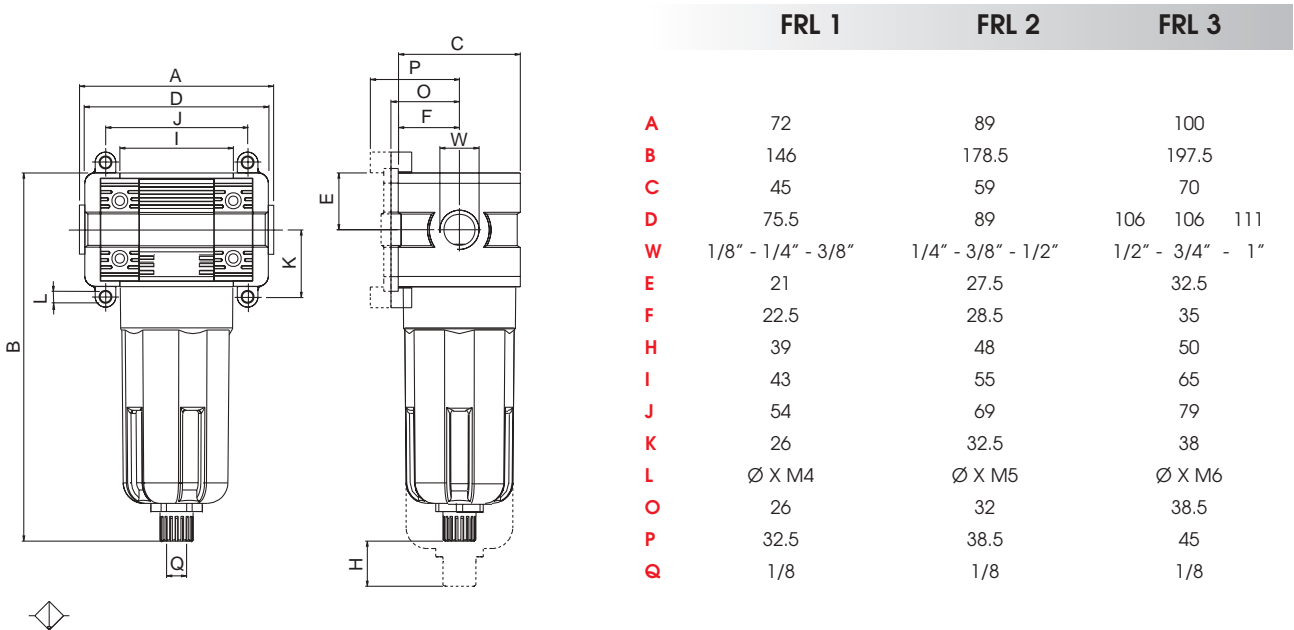

Especificaciones de material - Specifications

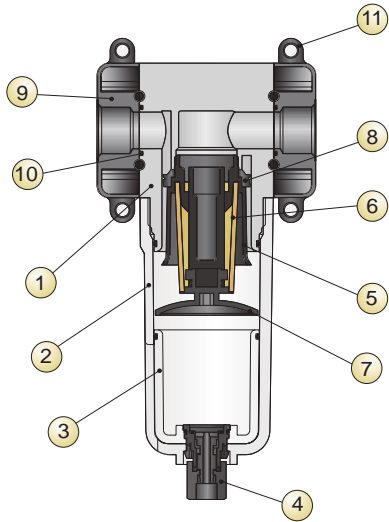

- | | | | |
|----|--|----|-------------------------------------|
| 1 | Cuerpo en tecnopolímero | 1 | Technopolymeric Body |
| 2 | Taza en tecnopolímero | 2 | Technopolymeric Bowl |
| 3 | Vaso en tecnopolímero transparente | 3 | Transparent technopolymeric Glass |
| 4 | Purga de condensados en tecnopolímero | 4 | Technopolymeric Condensate exhaust |
| 5 | Portafiltro en tecnopolímero | 5 | Technopolymeric Filter ring |
| 6 | Cartucho filtrante en bronce sinterizado | 6 | Sintered bronze Filtering cartridge |
| 7 | Deflector en tecnopolímero | 7 | Technopolymeric Deflector |
| 8 | Centrifugador en tecnopolímero | 8 | Technopolymeric Slinger |
| 9 | Terminal en Zama | 9 | Zama End part |
| 10 | Junta tórica en NBR | 10 | NBR O-Ring |
| 11 | Elemento de fijación / distancial | 11 | Fixing with distance |

Datos Técnicos - Technical data

CONEXIÓN ROSCADA / *THREADED FASTENING*
 CAUDAL A 6 BAR CON Δp 1 bar
6 bar FLOW RATE WITH Δp 1 bar
 TORNILLOS DE FIJACIÓN / *WALL CLAMPING SCREWS*
 CAPACIDAD TAZA / *BOWL CAPACITY*
 GRADO DE FILTRACIÓN / *FILTRATION GRADE*
 FLUIDO / *FLUID*
 PRESIÓN MAX / *MAXIMUM PRESSURE*
 TEMPERATURA / *TEMPERATURE*
 POSICIÓN DE MONTAJE / *ASSEMBLING POSITION*
 PURGA DE CONDENSADOS / *CONDENSATE EXHAUST*

	FRL 1	FRL 2	FRL 3
CONEXIÓN ROSCADA / <i>THREADED FASTENING</i>	1/8"-1/4"-3/8"	1/4" -3/8"-1/2"	1/2"-3/4"-1"
CAUDAL A 6 BAR CON Δp 1 bar <i>6 bar FLOW RATE WITH Δp 1 bar</i>	1900 NI/min	3750 NI/min	6250 NI/min
TORNILLOS DE FIJACIÓN / <i>WALL CLAMPING SCREWS</i>	M4X14	M5X18	M6X20
CAPACIDAD TAZA / <i>BOWL CAPACITY</i>	22 cm ³	46 cm ³	89.5 cm ³
GRADO DE FILTRACIÓN / <i>FILTRATION GRADE</i>	5 μm	20 μm STANDARD	50 μm
FLUIDO / <i>FLUID</i>	AIRE COMPRIMIDO / <i>COMPRESSED AIR</i>		
PRESIÓN MAX / <i>MAXIMUM PRESSURE</i>	15 bar		
TEMPERATURA / <i>TEMPERATURE</i>	Min -10 / Max +50°C a/to 10 bar		
POSICIÓN DE MONTAJE / <i>ASSEMBLING POSITION</i>	VERTICAL / <i>VERTICAL</i>		
PURGA DE CONDENSADOS / <i>CONDENSATE EXHAUST</i>	SEMIAUTOMÁTICO - MANUAL / <i>SEMI AUTOMATIC - MANUAL</i> AUTOMÁTICO / <i>AUTOMATIC</i>		

Características de caudal - Flow Characteristics

Tamaño / Size: FRL1

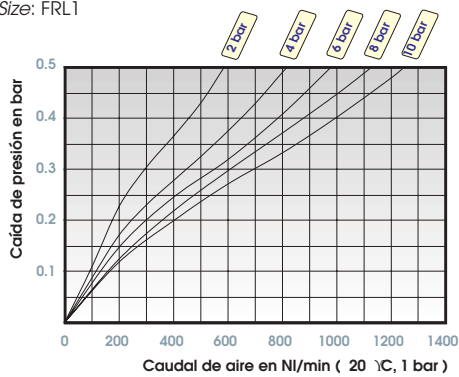

Tamaño / Size: FRL2

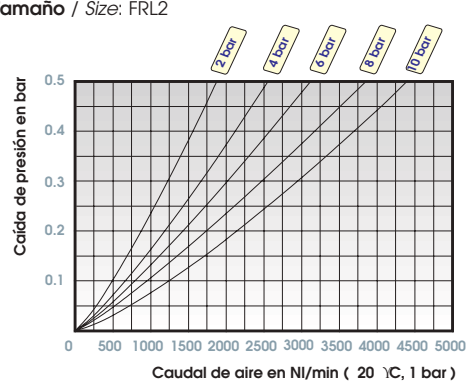

Tamaño / Size: FRL3

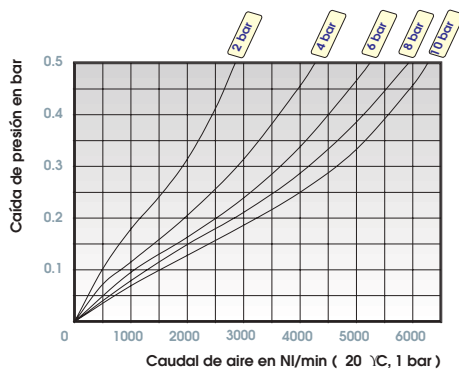

T015 Filtro Coalescente / Coalescer Filter



CÓDIGO DE LOS PRODUCTOS STANDARD EN STOCK - STANDARD PRODUCTS AVAILABLE IN STOCK

Código Code	Tamaño Size	Rosca Thread	Filtración Filtration	Caudal Flow Rate	Purga Exhaust
T015103401000	FC 1	1/4	0.01 µm	700 NI/min	S/M
T015104401000	FC 1	3/8	0.01 µm	700 NI/min	S/M
T015204401000	FC 2	3/8	0.01 µm	725 NI/min	S/M
T015205401000	FC 2	1/2	0.01 µm	725 NI/min	S/M
T015307401000	FC 3	3/4	0.01 µm	920 NI/min	S/M
T015309401000	FC 3	1"	0.01 µm	920 NI/min	S/M

S/M: Semiautomático / Manual
Semi Automatic / Manual

NB: CON EL FILTRO COALESCENTE T015 ACONSEJAMOS MONTAR UN FILTRO DE 5 µm
NB: WITH COALESCER FILTER T015 WE RECOMMEND TO INSTALL A 5 µm FILTER UPSTREAM.

Codificación artículos para su demanda - Article codes to be used for ordering

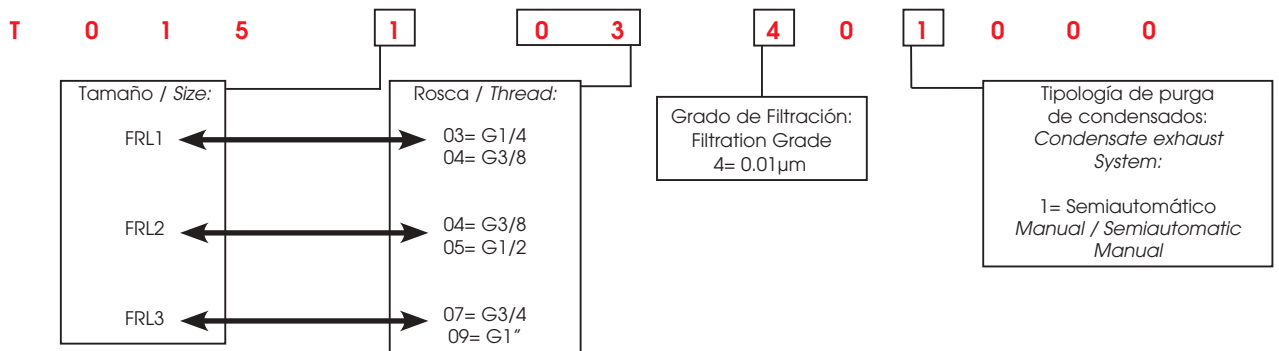

Dimensiones - Dimensions

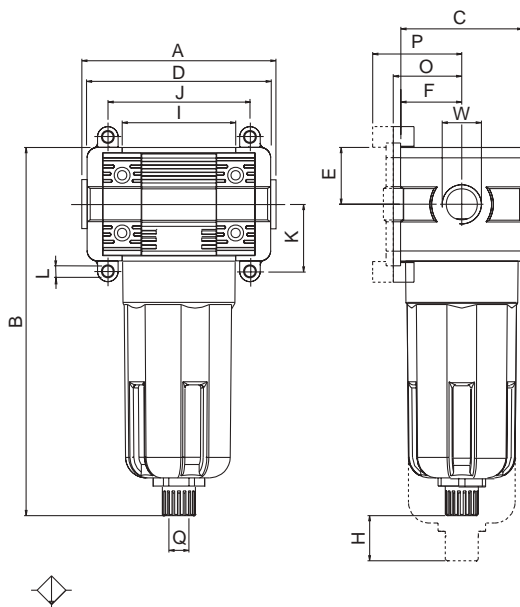

	FRL 1	FRL 2	FRL 3
A	72	89	100
B	146	178.5	197.5
C	45	59	70
D	75.5	89	106
W	1/8" - 1/4" - 3/8"	1/4" - 3/8" - 1/2"	1/2" - 3/4" - 1"
E	21	27.5	32.5
F	22.5	28.5	35
H	39	48	50
I	43	55	65
J	54	69	79
K	26	32	38.5
L	Ø X M4	Ø X M5	Ø X M6
O	26	32	38.5
P	32.5	38.5	45
Q	1/8	1/8	1/8

Especificaciones de material - Specifications

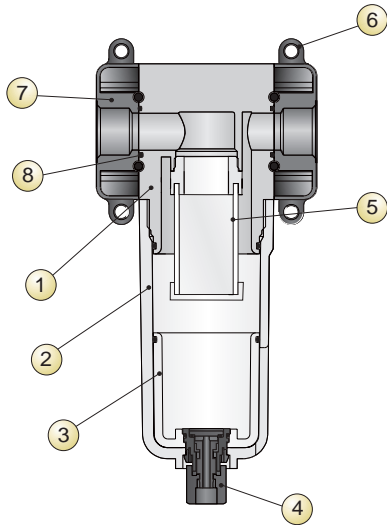

- | | |
|---|--------------------------------------|
| 1 Cuerpo en tecnopolímero | 1 Technopolymeric Body |
| 2 Taza en tecnopolímero | 2 Technopolymeric Bowl |
| 3 Vaso en tecnopolímero transparente | 3 Transparent technopolymeric Glass |
| 4 Purga de condensados en tecnopolímero | 4 Technopolymeric Condensate exhaust |
| 5 Cartucho Coalescente | 5 Coalescer cartridge |
| 6 Elemento de fijación / distancial | 6 Fixing with distance |
| 7 Terminal en Zama | 7 Zama End part |
| 8 Junta tórica en NBR | 8 NBR O-Ring |

Datos Técnicos - Technical data

CONEXIÓN ROSCADA / *THREADED FASTENING*
 CAUDAL A 6 BAR CON Δp 1 bar
6 bar FLOW RATE WITH Δp 1 bar
 TORNILLOS DE FIJACIÓN / *WALL CLAMPING SCREWS*
 CAPACIDAD TAZA / *BOWL CAPACITY*
 GRADO DE FILTRACIÓN / *FILTRATION GRADE*
 FLUIDO / *FLUID*
 PRESIÓN MAX / *MAXIMUM PRESSURE*
 TEMPERATURA / *TEMPERATURE*
 POSICIÓN DE MONTAJE / *ASSEMBLING POSITION*
 PURGA DE CONDENSADOS / *CONDENSATE EXHAUST*

	FRL 1	FRL 2	FRL 3
CONEXIÓN ROSCADA / <i>THREADED FASTENING</i>	1/4"-3/8"	3/8"-1/2"	3/4"-1"
CAUDAL A 6 BAR CON Δp 1 bar <i>6 bar FLOW RATE WITH Δp 1 bar</i>	700 NI/min	725 NI/min	920 NI/min
TORNILLOS DE FIJACIÓN / <i>WALL CLAMPING SCREWS</i>	M4X14	M5X18	M6X20
CAPACIDAD TAZA / <i>BOWL CAPACITY</i>	22 cm ³	46 cm ³	89.5 cm ³
GRADO DE FILTRACIÓN / <i>FILTRATION GRADE</i>		0.01 μ m	
FLUIDO / <i>FLUID</i>	AIRE COMPRIMIDO FILTRADO A 5 μ m / <i>5 μm FILTRED COMPRESSED AIR</i>		
PRESIÓN MAX / <i>MAXIMUM PRESSURE</i>	15 bar		
TEMPERATURA / <i>TEMPERATURE</i>	Min -10 / Max +50°C a/to 10 bar		
POSICIÓN DE MONTAJE / <i>ASSEMBLING POSITION</i>	VERTICAL / <i>VERTICAL</i>		
PURGA DE CONDENSADOS / <i>CONDENSATE EXHAUST</i>	SEMIAUTOMÁTICO - MANUAL / <i>SEMI AUTOMATIC - MANUAL</i>		

Información - Informations

CARTUCHO COALESCENTE
COALESCER CARTRIDGE

MICROFIBRAS CRUZADAS
INTERLACED MICROFIBERS

El cartucho coalescente está constituido de una capa de microfibras apoyado por una estructura externa de acero inox.
 El cartucho coalescente, utiliza los principios del impacto inercial, de la interceptación y la coalescencia, obliga a las partículas de líquido que lo atraviesan a unirse formando microgotas más grandes que, por gravedad precipitan en el fondo de la taza.
 El filtro coalescente utilizado como desoleador permite obtener un aire en la salida exento de aceite.
 Se aconseja de montar previamente al filtro coalescente un filtro de 5 μ m que retenga las partículas sólidas evitando así la obturación del cartucho coalescente.

*Coalescing cartridge is made of microfiber layer with external stainless steel structure. Coalescing cartridge uses inertial impact, interception and coalescence to gather liquid particles into drops. These drops will fall into bowl bottom.
 Coalescing Filter is used as Oil Separator which removes oil-vapours from air output. We recommend to install a 5 μ m Filter upstream to protect coalescing filter from choking of cartridge.*

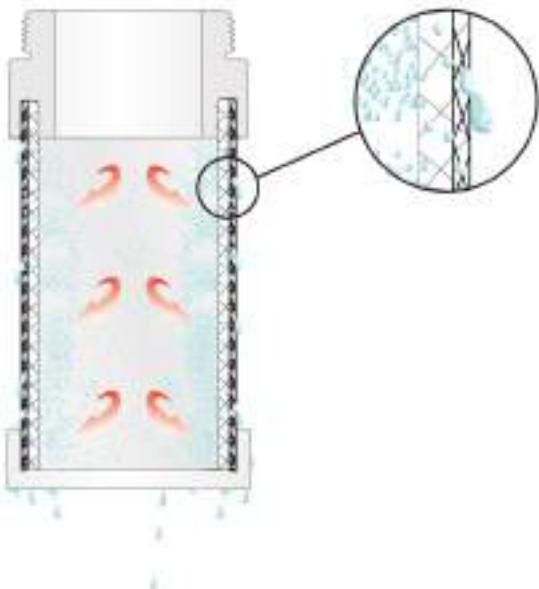

T020

Regulador / Regulator



CÓDIGO DE LOS PRODUCTOS STANDARD EN STOCK - STANDARD PRODUCTS AVAILABLE IN STOCK

Código Code	Tamaño Size	Rosca Thread	Regulación Regulation	Caudal Flow Rate
T020103030000	REG 1	1/4	0 - 8 bar	2050 NI/min
T020104030000	REG 1	3/8	0 - 8 bar	2050 NI/min
T020204030000	REG 2	3/8	0 - 8 bar	3200 NI/min
T020205030000	REG 2	1/2	0 - 8 bar	3200 NI/min
T020307030000	REG 3	3/4	0 - 8 bar	6200 NI/min
T020309030000	REG 3	1"	0 - 8 bar	6200 NI/min

Codificación artículos para su demanda - Article codes to be used for ordering

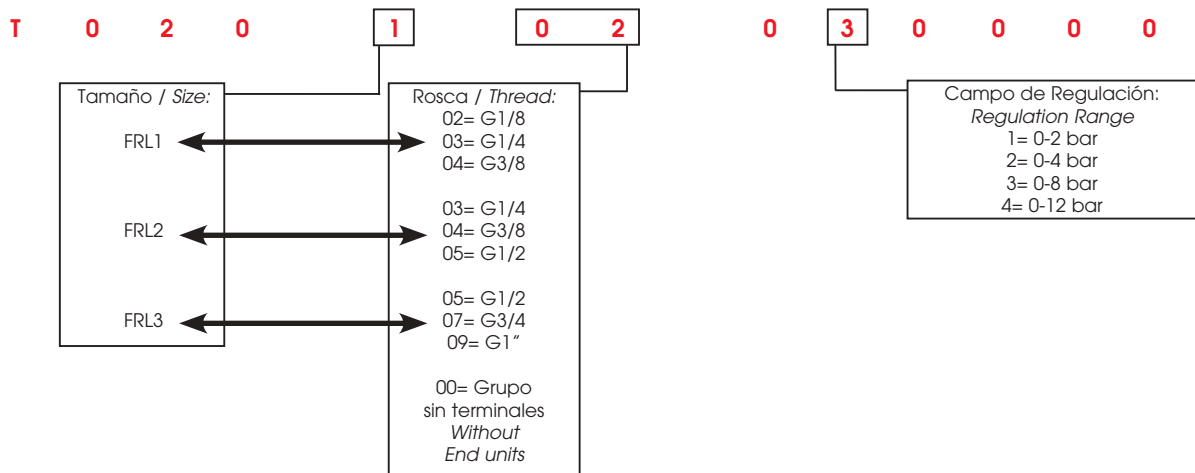

Dimensiones - Dimensions

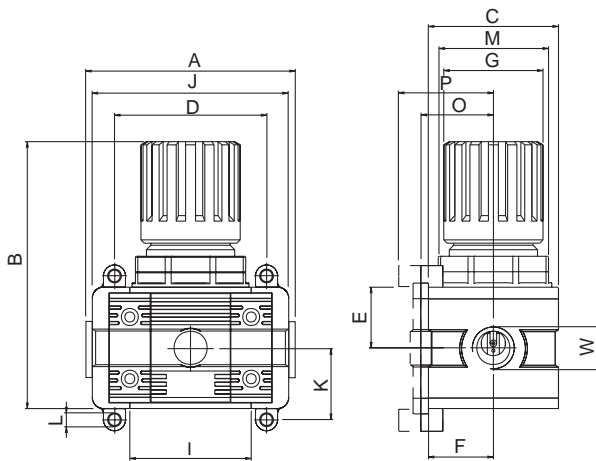

	FRL 1	FRL 2	FRL 3
A	72	89	100
B	97	121	140.5
C	45	59	70
D	75.5	89	106 106 111
W	1/8" - 1/4" - 3/8"	1/4" - 3/8" - 1/2"	1/2" - 3/4" - 1"
E	21	27.5	32.5
F	22.5	28.5	35
G	36	45	50.5
I	43	55	65
J	54	69	79
K	26	32.5	38
L	Ø X M4	Ø X M5	Ø X M6
O	26	32	38.5
P	32.5	38.5	45



Especificaciones de material - Specifications

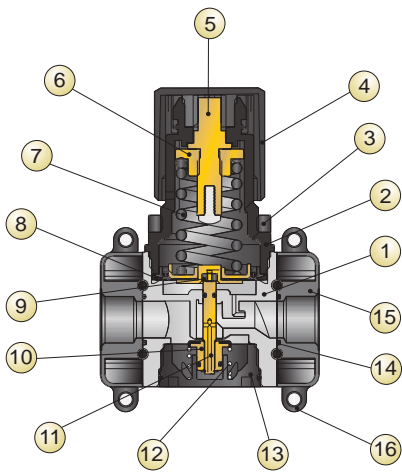

- 1 Cuerpo en tecnopolímero
- 2 Campana en tecnopolímero
- 3 Tuerca de fijación en tecnopolímero
- 4 Pomo en tecnopolímero
- 5 Tornillo de registro en latón
- 6 Tuerca hembra en latón
- 7 Muelle de registro en acero
- 8 Membrana
- 9 Junta relieving en NBR
- 10 Obturador con junta vulcanizada en NBR
- 11 Eje en latón
- 12 Muelle obturador en acero inox
- 13 Tapón en tecnopolímero
- 14 Junta tórica en NBR
- 15 Terminal en Zama
- 16 Elemento de fijación / distancial

- 1 Technopolymeric Body
- 2 Technopolymeric Bell
- 3 Technopolymeric Fixing nut
- 4 Technopolymeric Knob
- 5 Brass Register screw
- 6 Brass Female screw
- 7 Steel Register spring
- 8 Rolling membrane
- 9 NBR seal Relieving diaphragm
- 10 NBR Shutter with vulcanized
- 11 Brass Rod
- 12 Stainless steel Push - shutter spring
- 13 Technopolymeric Plug
- 14 NBR O-Ring
- 15 Zama End part
- 16 Fixing with distance

Datos Técnicos - Technical data

CONEXIÓN ROSCADA / *THREADED FASTENING*
 CAUDAL A 6 BAR CON Δp 1 bar
6 bar FLOW RATE WITH Δp 1 bar
 TORNILLOS DE FIJACIÓN / *WALL CLAMPING SCREWS*
 CONEXIÓN MANÓMETRO / *MANOMETER FASTENING*
 CAMPO DE REGULACIÓN / *REGULATION RANGE*

FLUIDO / *FLUID*
 PRESIÓN MAX / *MAXIMUM PRESSURE*
 TEMPERATURA / *TEMPERATURE*
 POSICIÓN DE MONTAJE / *ASSEMBLING POSITION*

	FRL 1	FRL 2	FRL 3
CONEXIÓN ROSCADA / <i>THREADED FASTENING</i>	1/8"-1/4"-3/8"	1/4" -3/8"-1/2"	1/2"-3/4"-1"
CAUDAL A 6 BAR CON Δp 1 bar <i>6 bar FLOW RATE WITH Δp 1 bar</i>	2050 NI/min	3200 NI/min	6200 NI/min
TORNILLOS DE FIJACIÓN / <i>WALL CLAMPING SCREWS</i>	M4X14	M5X18 G 1/8"	M6X20
CONEXIÓN MANÓMETRO / <i>MANOMETER FASTENING</i>			
CAMPO DE REGULACIÓN / <i>REGULATION RANGE</i>	0 ÷ 2 bar	0 ÷ 4 bar 0 ÷ 8 bar Standard	0 ÷ 12 bar
FLUIDO / <i>FLUID</i>		AIRE COMPRIMIDO / <i>COMPRESSED AIR</i>	
PRESIÓN MAX / <i>MAXIMUM PRESSURE</i>		15 bar	
TEMPERATURA / <i>TEMPERATURE</i>		Min -10 / Max +50°C a/to 10 bar	
POSICIÓN DE MONTAJE / <i>ASSEMBLING POSITION</i>		VERTICAL / <i>VERTICAL</i>	

Características de caudal - Flow Characteristics

Tamaño / Size: FRL1

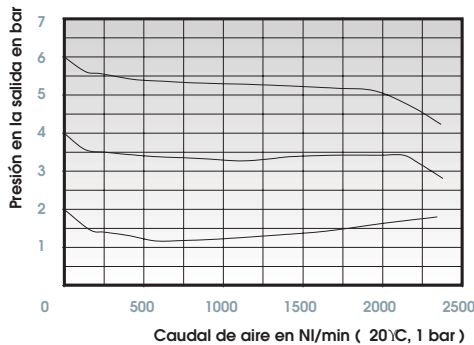

Tamaño / Size: FRL2

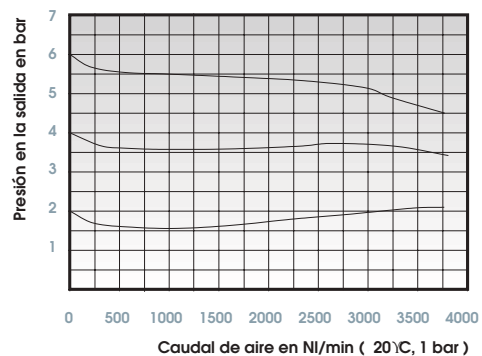

Tamaño / Size: FRL3

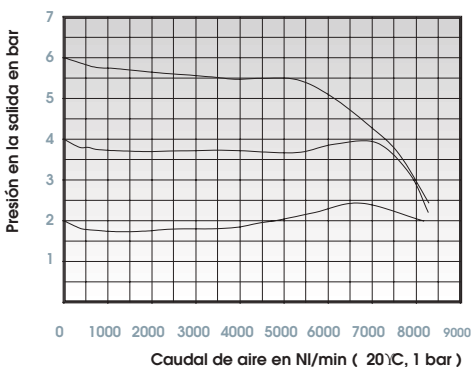

T030

Filtroregulador / Filter Regulator



CÓDIGO DE LOS PRODUCTOS STANDARD EN STOCK - STANDARD PRODUCTS AVAILABLE IN STOCK

Código Code	Tamaño Size	Rosca Thread	Filtración Filtration	Regulación Regulation	Caudal Flow Rate	Purga Exhaust
T030103231000	FR 1	1/4	20 µm	0 - 8 bar	1650 NI/min	S/M
T030104231000	FR 1	3/8	20 µm	0 - 8 bar	1650 NI/min	S/M
T030204231000	FR 2	3/8	20 µm	0 - 8 bar	3000 NI/min	S/M
T030205231000	FR 2	1/2	20 µm	0 - 8 bar	3000 NI/min	S/M
T030205232000	FR 2	1/2	20 µm	0 - 8 bar	3000 NI/min	A
T030307231000	FR 3	3/4	20 µm	0 - 8 bar	4500 NI/min	S/M
T030309231000	FR 3	1"	20 µm	0 - 8 bar	4500 NI/min	S/M
T030309232000	FR 3	1"	20 µm	0 - 8 bar	4500 NI/min	A

S/M: Semiautomático / Manual
Semi Automatic / Manual

A: Automático / Automatic

Codificación artículos para su demanda - Article codes to be used for ordering

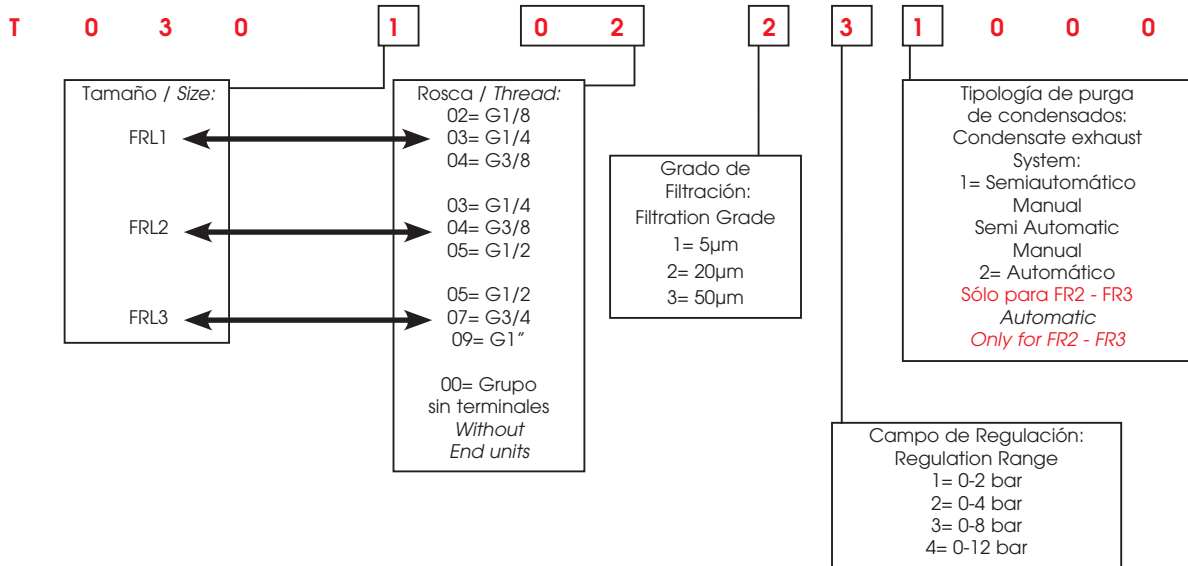

Dimensiones - Dimensions

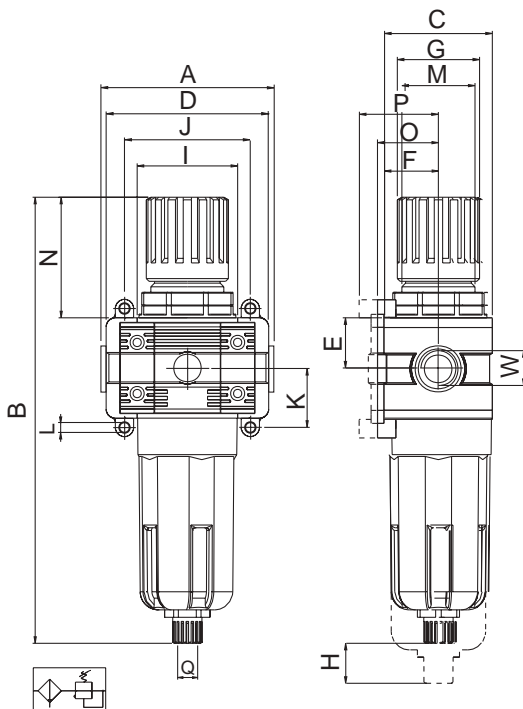

	FRL 1	FRL 2	FRL 3
A	72	89	100
B	198	244.5	273
C	45	59	70
D	75.5	89	106 106 111
W	1/8" - 1/4" - 3/8"	1/4" - 3/8" - 1/2"	1/2" - 3/4" - 1"
E	21	27.5	32.5
F	22.5	28.5	35
G	36	45	50.5
H	39	48	50
I	43	55	65
J	54	69	79
K	26	32.5	38
L	Ø X M4	Ø X M5	Ø X M6
M	M32 X 1.5	M40 X 1.5	M47 X 1.5
N	52	66	75.5
O	26	32	38.5
P	32.5	38.5	45
Q	1/8	1/8	1/8

Especificaciones de material - Specifications

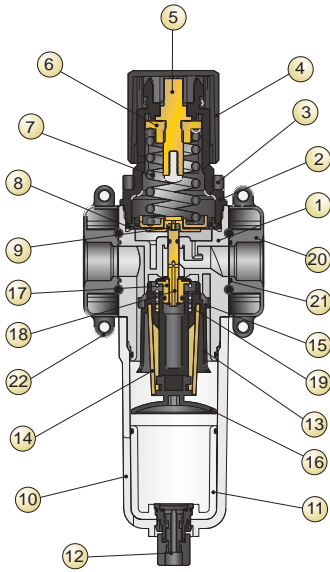

- | | |
|---|--|
| 1 Cuerpo en tecnopolímero | 1 Technopolymeric Body |
| 2 Campana en tecnopolímero | 2 Technopolymeric Bell |
| 3 Tuerca de fijación en tecnopolímero | 3 Technopolymeric Fixing nut |
| 4 Pomo en tecnopolímero | 4 Technopolymeric Knob |
| 5 Tornillo de registro en latón | 5 Brass Register screw |
| 6 Tuerca hembra en latón | 6 Brass Female screw |
| 7 Muelle de registro en acero | 7 Steel Register spring |
| 8 Membrana | 8 Rolling membrane |
| 9 Junta relieving en NBR | 9 NBR "Relieving" diaphragm |
| 10 Taza en tecnopolímero | 10 Technopolymeric Bowl |
| 11 Vaso en tecnopolímero transparente | 11 Transparent Technopolymeric Glass |
| 12 Purga de condensados en tecnopolímero | 12 Technopolymeric Condensate exhaust |
| 13 Portafiltro en tecnopolímero | 13 Technopolymeric Filter ring |
| 14 Cartucho filtrante en bronce sinterizado | 14 Sintered bronze Filtering cartridge |
| 15 Centrífugador en tecnopolímero | 15 Technopolymeric Slinger |
| 16 Deflector en tecnopolímero | 16 Technopolymeric Deflector |
| 17 Obturador con junta vulcanizada en NBR | 17 NBR Shutter with vulcanised diaphragm |
| 18 Eje en latón | 18 Brass Rod |
| 19 Muelle obturador en acero inox | 19 Stainless steel Push - shutter spring |
| 20 Terminal en Zama | 20 Zama End part |
| 21 Junta tórica en NBR | 21 NBR O-Ring |
| 22 Elemento de fijación / distancial | 22 Fixing with distance |

Datos Técnicos - Technical data

	FRL 1	FRL 2	FRL 3
CONEXIÓN ROSCADA / THREADED FASTENING	1/8"-1/4"-3/8"	1/4" -3/8"-1/2"	1/2"-3/4"-1"
CAUDAL A 6 BAR CON Δp 1 bar 6 bar FLOW RATE WITH Δp 1 bar	1650 NI/min	3000 NI/min	4500 NI/min
TORNILLOS DE FIJACIÓN / WALL CLAMPING SCREWS	M4X14	M5X18	M6X20
CAPACIDAD TAZA / BOWL CAPACITY	22 cm ³	46 cm ³	89.5 cm ³
GRADO DE FILTRACIÓN / FILTRATION GRADE	5µm	20µm Standard	50µm
CAMPO DE REGULACIÓN / REGULATION RANGE	0 ÷ 2 bar	0 ÷ 4 bar 0 ÷ 8 bar Standard	0 ÷ 12 bar
FLUIDO / FLUID	AIRE COMPRIMIDO / COMPRESSED AIR		
PRESIÓN MAX / MAXIMUM PRESSURE	15 bar		
TEMPERATURA / TEMPERATURE	Min -10 / Max +50°C a/to 10 bar		
POSICIÓN DE MONTAJE / ASSEMBLING POSITION	VERTICAL / VERTICAL		
CONEXIÓN MANÓMETRO / MANOMETER FASTENING	G 1/8"		
PURGA DE CONDENSADOS / CONDENSATE EXHAUST	SEMIAUTOMÁTICO - MANUAL / SEMI AUTOMATIC - MANUAL AUTOMÁTICO / AUTOMATIC		

Características de caudal - Flow Characteristics

Tamaño / Size: FRL1

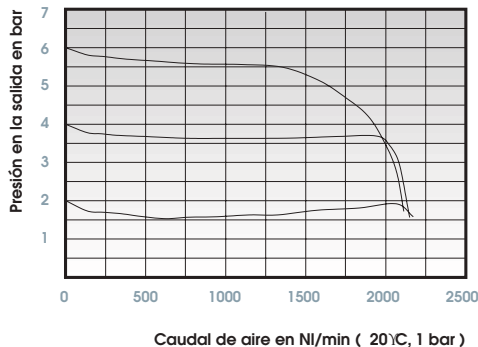

Tamaño / Size: FRL2

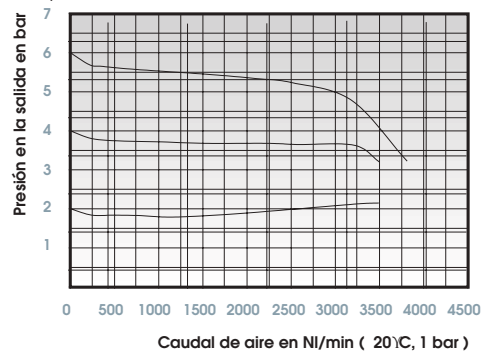

Tamaño / Size: FRL3

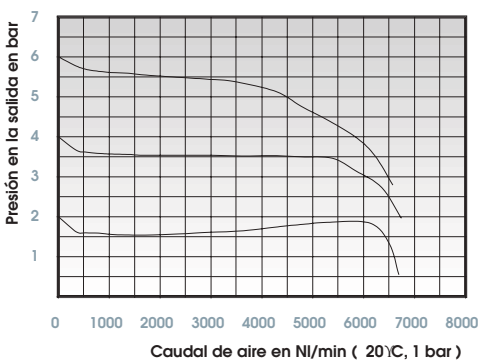

T040

Lubricador / Lubricator



CÓDIGO DE LOS PRODUCTOS STANDARD EN STOCK - STANDARD PRODUCTS AVAILABLE IN STOCK

Código Code	Tamaño Size	Rosca Thread	Caudal Flow Rate	Carga de aceite Oil Load
T040103000100	LUB 1	1/4	2600 NI/min	M
T040104000100	LUB 1	3/8	2600 NI/min	M
T040104000200	LUB 1	3/8	2600 NI/min	A
T040204000100	LUB 2	3/8	5600 NI/min	M
T040205000100	LUB 2	1/2	5600 NI/min	M
T040205000200	LUB 2	1/2	5600 NI/min	A
T040307000100	LUB 3	3/4	8200 NI/min	M
T040309000100	LUB 3	1"	8200 NI/min	M
T040309000200	LUB 3	1"	8200 NI/min	A
T040309000300	LUB 3	1"	8200 NI/min	M2L

M: Manual Manual
 M2L: Manual con sensor de 2 niveles Two steps sensor Manual
 A: Automático a depresión Automatic to Vacuum-operated

Codificación artículos para su demanda - Article codes to be used for ordering

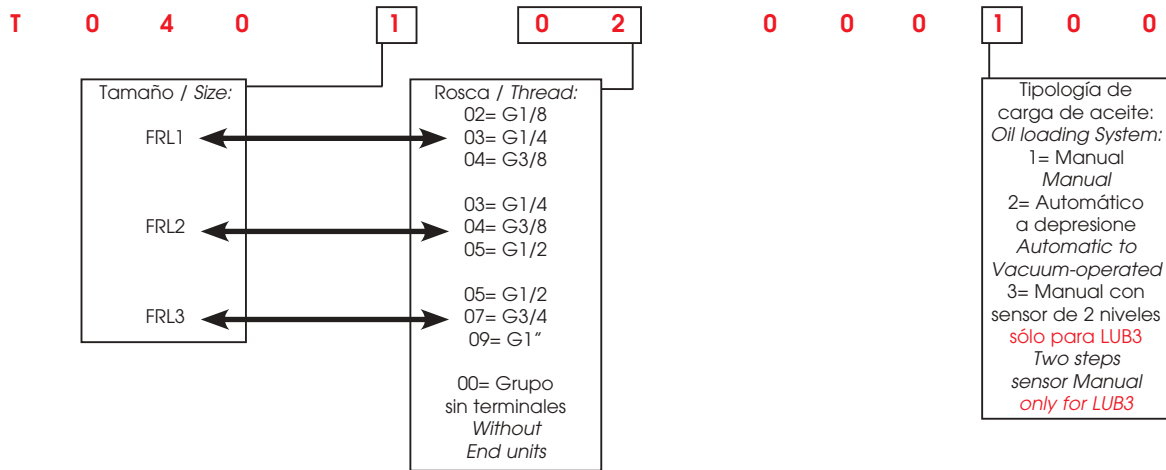

Dimensiones - Dimensions

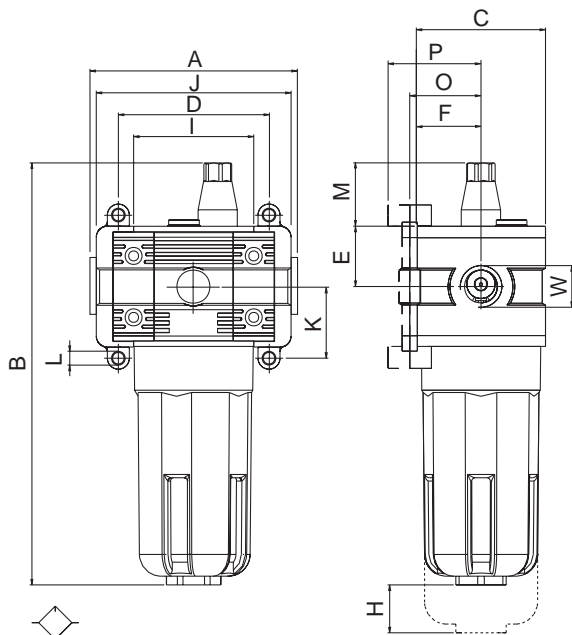

	FRL 1	FRL 2	FRL 3
A	72	89	100
B	162	195	214
C	45	59	70
D	75.5	89	106 106 111
W	1/8" - 1/4" - 3/8"	1/4" - 3/8" - 1/2"	1/2" - 3/4" - 1"
E	21	27.5	32.5
F	22.5	28.5	35
H	39	48	50
I	43	55	65
J	48.5	69	79
K	26	32.5	38
L	Ø X M4	Ø X M5	Ø X M6
M	29	29	29
O	26	32	38.5
P	32.5	38.5	45

Especificaciones de material - Specifications

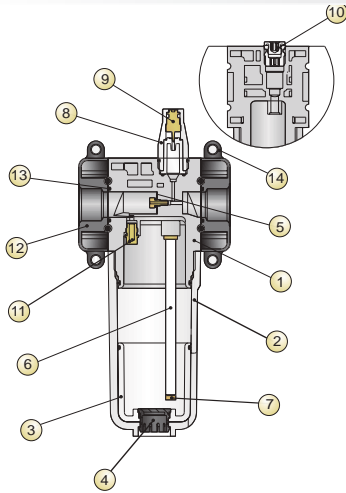

- | | | | |
|----|--|----|---|
| 1 | Cuerpo en tecnopolímero | 1 | Technopolymeric Body |
| 2 | Taza en tecnopolímero | 2 | Technopolymeric Bowl |
| 3 | Vaso en tecnopolímero transparente | 3 | Transparent technopolymeric Glass |
| 4 | Tapón en tecnopolímero | 4 | Technopolymeric Plug |
| 5 | Membrana dispositivo Venturi | 5 | Membrane Venturi device |
| 6 | Tubo aspiración aceite en PA11 | 6 | PA11 Oil aspiration tube |
| 7 | Filtro pequeño | 7 | Small filter |
| 8 | Cúpula visor en tecnopolímero transparente | 8 | Transparent technopolymeric Visual dome |
| 9 | Tornillo de regulación caudal de aceite en latón | 9 | Brass Oil regulating capacity pin |
| 10 | Tapón carga aceite en latón | 10 | Brass Oil loading plug |
| 11 | Difusor aire en latón | 11 | Brass Air diffuser |
| 12 | Terminal en Zama | 12 | Zama End part |
| 13 | Junta tórica en NBR | 13 | NBR O-Ring |
| 14 | Elemento de fijación / distancial | 14 | Fixing with distance |

Datos Técnicos - Technical data

CONEXIÓN ROSCADA / *THREADED FASTENING*
 CAUDAL A 6 BAR CON Δp 1 bar
6 bar FLOW RATE WITH Δp 1 bar
 TORNILLOS DE FIJACIÓN / *WALL CLAMPING SCREWS*
 CAPACIDAD TAZA / *BOWL CAPACITY*
 FLUIDO / *FLUID*
 PRESIÓN MAX / *MAXIMUM PRESSURE*
 TEMPERATURA / *TEMPERATURE*
 POSICIÓN DE MONTAJE / *ASSEMBLING POSITION*
 ACEITE ACONSEJADO / *RECOMMENDED OILS*
 CARGA DE ACEITE / *OIL LOADING*

FRL 1	FRL 2	FRL 3
1/8"-1/4"-3/8"	1/4"-3/8"-1/2"	1/2"-3/4"-1"
2600 NI/min	5600 NI/min	8200 NI/min
M4X14	M5X18	M6X20
22 cm ³	46 cm ³	89.5 cm ³
AIRE COMPRIMIDO / <i>COMPRESSED AIR</i>		
15 bar		
Min -10 / Max +50°C a/to 10 bar		
VERTICAL / <i>VERTICAL</i>		
Clase ISO 22 a Norma ISO 3448		
MANUAL - AUTOMÁTICO A DEPRESIÓN		
MANUAL - <i>AUTOMATIC VACUUM-OPERATED</i>		
MANUAL CON SENSOR DE 2 NIVELES		
TWO STEPS		
SENSOR MANUAL		

Características de caudal - Flow Characteristics

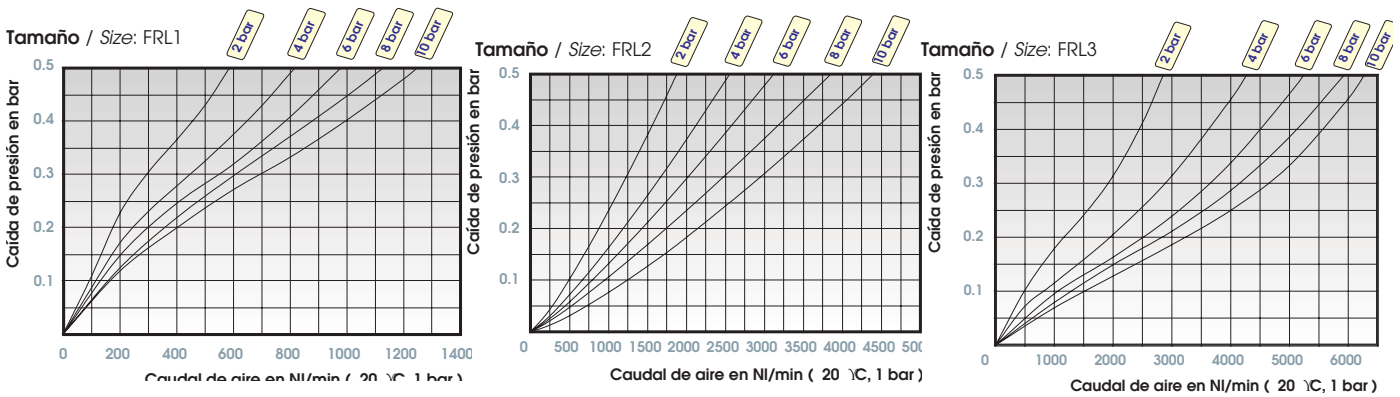

Esquema eléctrico carga manual aceite a 2 niveles / Electrical data oil loading system Two steps sensor Manual

Señal al nivel mínimo
Minimum Level

Señal al nivel máximo
Maximum Level

Señal del nivel de aceite al mínimo y al máximo
Minimum and Maximum Level oil

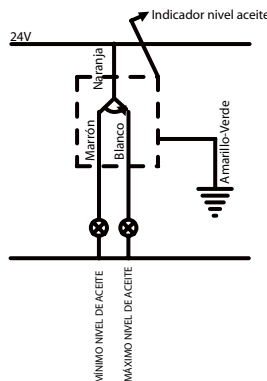
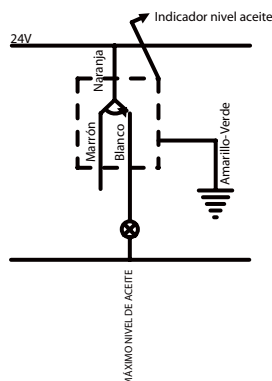
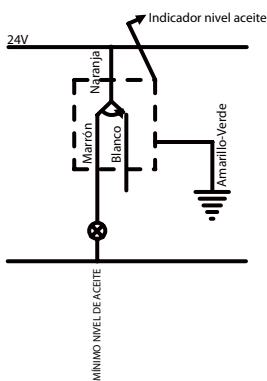

LONGITUD CABLE 1500 mm
CABLE LENGHT 1500 mm
CORRIENTE / CURRENT 0.5A
TENSIÓN / VOLTAGE <24V
CAPACIDAD / CAPACITY 10W

T050

Válvula de Corte / Shut off Valve

CÓDIGO DE LOS PRODUCTOS STANDARD EN STOCK - STANDARD PRODUCTS AVAILABLE IN STOCK



Código Code	Tamaño Size	Rosca Thread	Caudal Flow Rate	Comando Drive
T050103000010	V3V 1	1/4	1850 NI/min	M
T050104000010	V3V 1	3/8	1850 NI/min	M
T050104000020	V3V 1	3/8	1850 NI/min	EP
T050104000030	V3V 1	3/8	1850 NI/min	P
T050204000010	V3V 2	3/8	3000 NI/min	M
T050205000010	V3V 2	1/2	3000 NI/min	M
T050205000020	V3V 2	1/2	3000 NI/min	EP
T050205000030	V3V 2	1/2	3000 NI/min	P
T050307000010	V3V 3	3/4	5200 NI/min	M
T050309000010	V3V 3	1"	5200 NI/min	M
T050309000020	V3V 3	1"	5200 NI/min	EP
T050309000030	V3V 3	1"	5200 NI/min	P

M: Manual / Manual

P: Neumático / Pneumatic

Candado incluido / Padlock included in the packing

*EP: Electronéumático / Electropneumatic

*NB: STANDARD SIN SOLENOIDE VER PAG. 17.48 - STANDARD WITHOUT SOLENOID SEE PAG. 17.48

NB: La válvula de corte electroneumática no puede ser utilizada en atmósfera potencialmente explosiva según la directiva ATEX. NB: According to the Directive ATEX Shut off valves cannot be used in potentially explosive environment.

Codificación artículos para su demanda - Article codes to be used for ordering

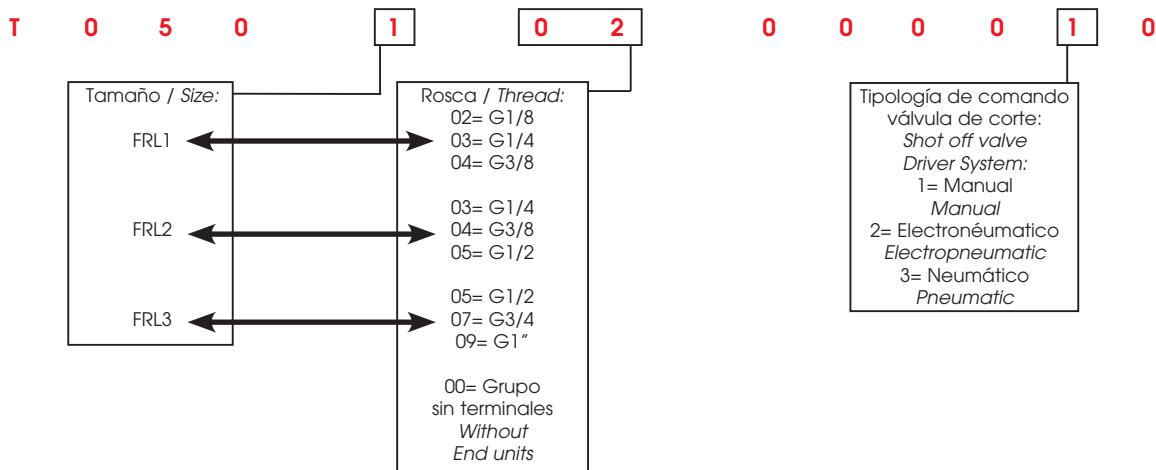

Dimensiones - Dimensions

MANUAL - MANUAL

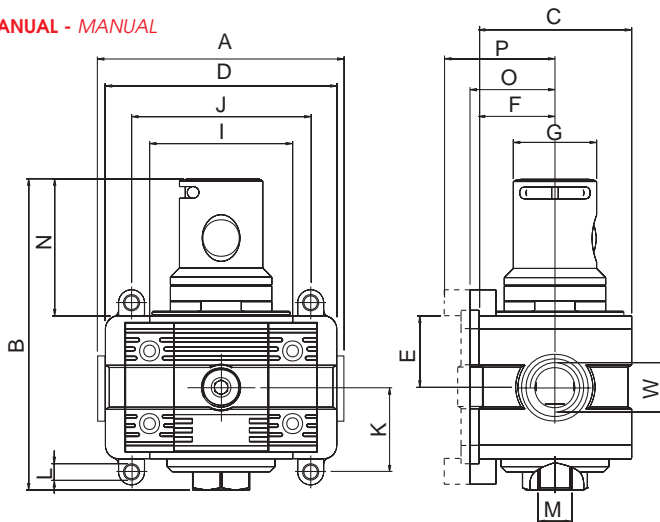

	FRL 1	FRL 2	FRL 3
A	72	89	100
B	105.5	119.5	131.5
C	45	59	70
D	75.5	89	106 106 111
W	1/8" - 1/4" - 3/8"	1/4" - 3/8" - 1/2"	1/2" - 3/4" - 1"
E	21	27.5	32.5
F	22.5	28.5	35
G	32	32	32
I	43	55	65
J	54	69	79
K	26	32.5	38
L	Ø X M4	Ø X M5	Ø X M6
M	1/8"	1/4"	3/8"
N	52.5	52.5	52.5
O	26	32	38.5
P	32.5	38.5	45

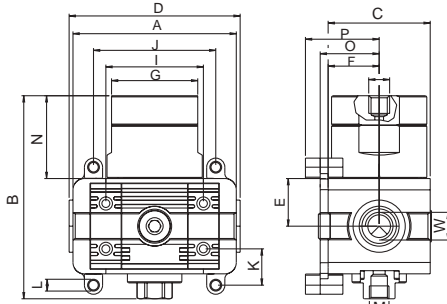
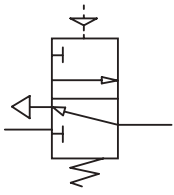
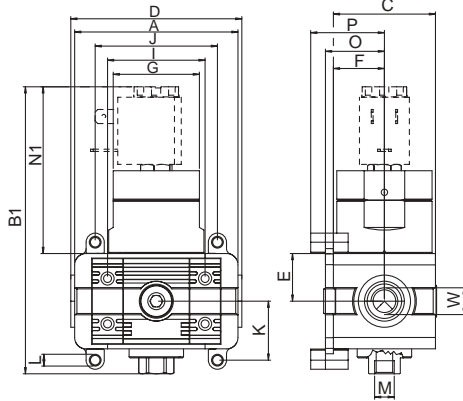
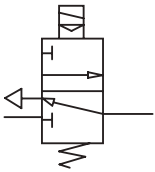

Dimensiones - Dimensions
NEUMÁTICO - PNEUMATIC

**ELECTRONEUMÁTICO
ELECTROPNEUMATIC**

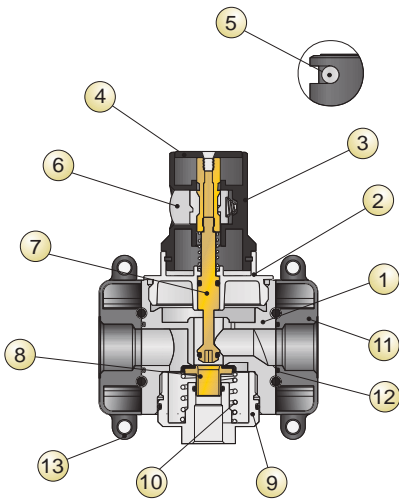
	FRL 1	FRL 2	FRL 3
A	72	89	100
B	89.5	100.15	108
BI	126.5	137.15	144.9
C	45	59	70
D	75.4	89	106 - 106 - 111
W	1/8" - 1/4" - 3/8"	1/4" - 3/8" - 1/2"	1/2" - 3/4" - 1"
E	21	27.5	32.5
F	22.5	29.5	35
G	38	38	38
I	43	55	65
J	54	69	79
K	16	32.5	38
L	Ø X M4	Ø X M5	Ø X M6
M	1/8"	1/4"	3/8"
N	36.5	32.7	29
NI	73.5	69.6	65.9
O	26	32	38.5
P	32.5	38.5	45
Q	1/8"	1/8"	1/8"

Especificaciones de material - Specifications

- 1 Cuerpo en tecnopolímero
- 2 Tapón superior en latón
- 3 Pomo en tecnopolímero
- 4 Pulsador para la apertura del circuito
- 5 Orificio de inserción del candado de seguridad
- 6 Pulsador para el cierre del circuito
- 7 Eje en latón
- 8 Obturador con junta vulcanizada en NBR
- 9 Tapón inferior en latón
- 10 Muelle obturador en acero inox
- 11 Terminal en Zama
- 12 Junta tórica en NBR
- 13 Elemento de fijación / distancial

- 1 Technopolymeric Body
- 2 Brass Upper plug
- 3 Technopolymeric Knob
- 4 Push button to open the circuit
- 5 Slotted hole to insert the security lock
- 6 Push button to close the circuit
- 7 Stem made in Brass
- 8 NBR Shutter with vulcanized seal
- 9 Brass Lower plug
- 10 Stainless steel Push - shutter spring
- 11 Zama End part
- 12 NBR O-Ring
- 13 Fixing with distance

Datos Técnicos - Technical data

CONEXIÓN ROSCADA / THREADED FASTENING

CAUDAL A 6 BAR CON Δp 1 bar

6 bar FLOW RATE WITH Δp 1 bar

TORNILLOS DE FIJACIÓN / WALL CLAMPING SCREWS

FLUIDO / FLUID

PRESIÓN MAX / MAXIMUM PRESSURE

TEMPERATURA / TEMPERATURE

POSICIÓN DE MONTAJE / ASSEMBLING POSITION

TIPO DE COMANDO / DRIVE SYSTEM

SOLENOIDE / SOLENOID

	FRL 1	FRL 2	FRL 3
CONEXIÓN ROSCADA / THREADED FASTENING	1/8"-1/4"-3/8"	1/4" -3/8"-1/2"	1/2"-3/4"-1"
CAUDAL A 6 BAR CON Δp 1 bar 6 bar FLOW RATE WITH Δp 1 bar	1850 NI/min	3000 NI/min	5200 NI/min
TORNILLOS DE FIJACIÓN / WALL CLAMPING SCREWS	M4X14	M5X18	M6X20
FLUIDO / FLUID	AIRE COMPRIMIDO / COMPRESSED AIR		
PRESIÓN MAX / MAXIMUM PRESSURE	15 bar (de 2 a 10 bar para Electroneumático - From 2 to 10 bar for Electropneumatic)		
TEMPERATURA / TEMPERATURE	Min -10 / Max +50°C a/to 10 bar		
POSICIÓN DE MONTAJE / ASSEMBLING POSITION	VERTICAL / VERTICAL		
TIPO DE COMANDO / DRIVE SYSTEM	MANUAL / MANUAL		
	NEUMÁTICO / PNEUMATIC		
	ELECTRONEUMÁTICO - ELECTROPNEUMATIC		
	24V DC 3W - 220V AC 5VA		

T060

Válvula de arranque progresivo con escape rápido Soft start valve with quick exhaust



CÓDIGO DE LOS PRODUCTOS STANDARD EN STOCK - STANDARD PRODUCTS AVAILABLE IN STOCK

Código Code	Tamaño Size	Rosca Thread	Comando Drive
T060104000002	APE 1	3/8	EP
T060204000002	APE 2	3/8	EP
T060205000002	APE 2	1/2	EP
T060307000002	APE 3	3/4	EP
T060309000002	APE 3	1"	EP

EP: Electronéumático - Electropneumatic

NB: STANDARD SIN SOLENOIDE VER PAG. 17.48 - STANDARD WITHOUT SOLENOID SEE PAG. 17.48

NB: La válvula de arranque progresivo no puede ser utilizada en atmósfera potencialmente explosiva según la directiva ATEX.

NB: According to the Directive ATEX soft start valves cannot be used in potentially explosive environment.

Codificación artículos para su demanda - Article codes to be used for ordering

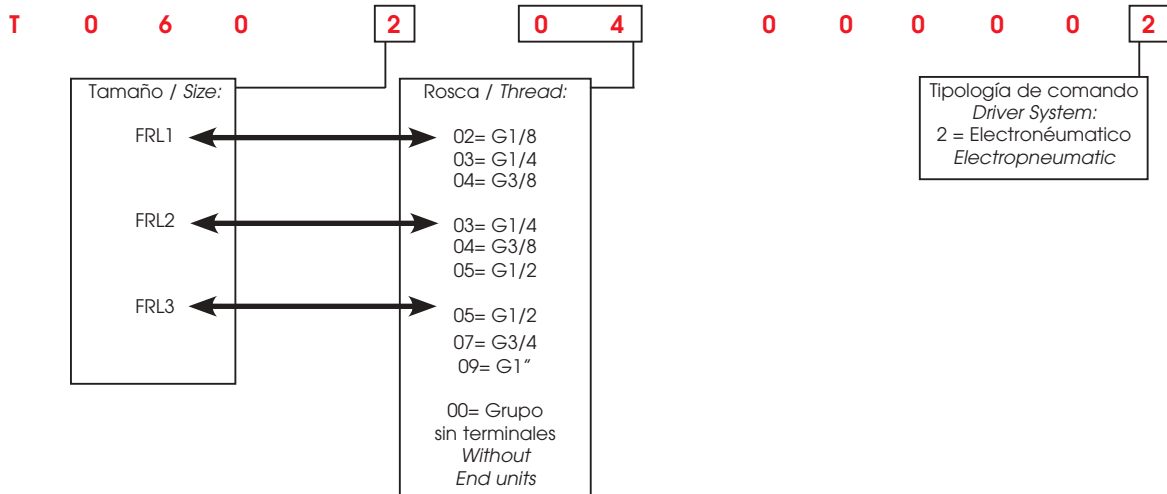

Dimensiones - Dimensions

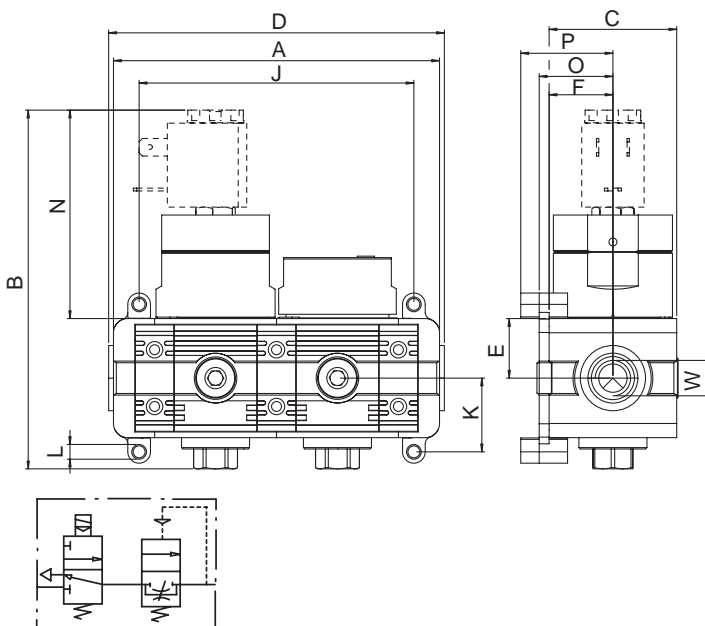

	FRL 1
A	115
B	126.5
C	45
D	118.4
W	1/8 - 1/4 - 3/8
E	21
F	22.5
J	97
K	26
L	ØxM5
N	73.5
P	32.5
O	26

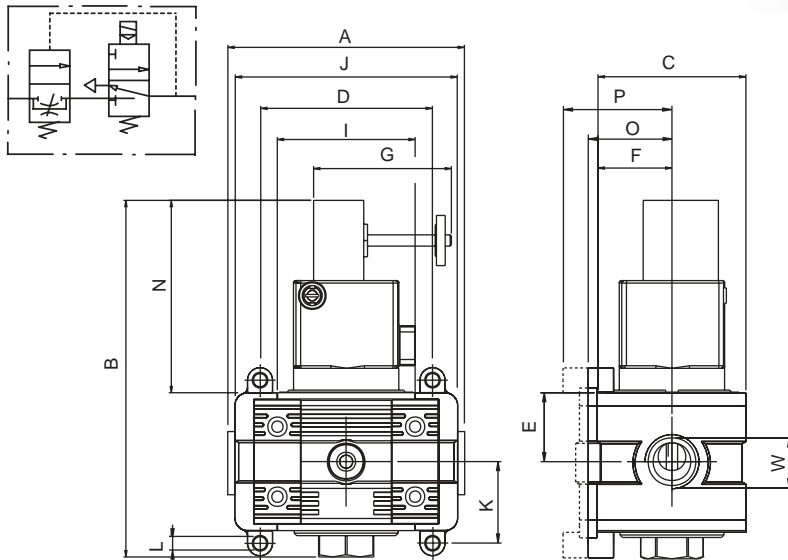

	FRL 2	FRL 3
A	104	115
B	142	131.5
C	59	70
D	89	106 106 111
W	1/4 - 3/8 - 1/2	1/2 - 3/4 - 1
E	27.5	32.5
F	28.5	35
G	55.5	55.5
I	55	65
J	97	109
K	32.5	38
L	∅xM5	∅xM5
N	76.5	76.5
O	32	38.5
P	38.5	45

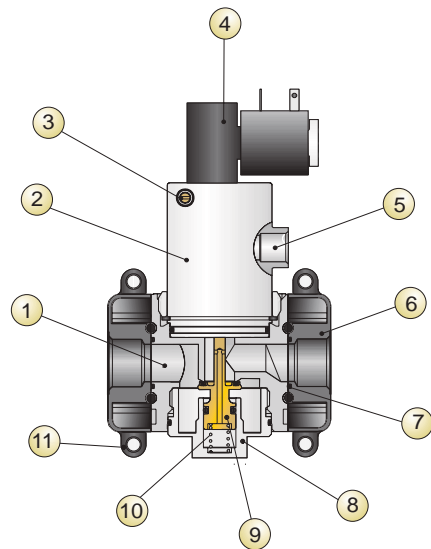
Especificaciones de material - Specifications

- 1 Cuerpo en tecnopolímero
- 2 Grupo de comando en latón
- 3 Tornillo regulador de caudal en latón
- 4 Electropiloto
- 5 Salida del escape rápido
- 6 Terminal en Zama
- 7 Junta tórica en NBR
- 8 Tapón inferior en latón
- 9 Obturador en latón con junta tórica integrada
- 10 Muelle obturador en acero inox
- 11 Elemento de fijación / distancial

- 1 Technopolymeric Body
- 2 Brass Impulse group
- 3 Brass Adjusting screw
- 4 Electronic pilot
- 5 Exit of the quick exhaust
- 6 Zamac End part
- 7 NBR O-ring
- 8 Brass Lower plug
- 9 Brass Shutter with integrated O-ring
- 10 Stainless steel Shutter spring
- 11 Fixing with distance

Datos Técnicos - Technical data

	FRL 1	FRL 2	FRL 3
CONEXIÓN ROSCADA / THREADED FASTENING	1/4"-3/8"-1/2"	1/4"-3/8"-1/2"	1/2"-3/4"-1"
TORNILLOS DE FIJACIÓN / WALL CLAMPING SCREWS	M5X18	M5X18	M6X20
PRESIÓN MAX DE ENTRADA / MAXIMUM INLET PRESSURE	4-10 bar	4-10 bar	3-10 bar
FLUIDO / FLUID	AIRE COMPRIMIDO / COMPRESSED AIR		
CONEXIÓN ROSCADA SALIDA ESCAPE RÁPIDO / FASTENING QUICK EXHAUST	1/8"	1/4"	
TEMPERATURA / TEMPERATURE	Min -10 / Max +50°C a/to 10 bar		
POSICIÓN DE MONTAJE / ASSEMBLING POSITION	VERTICAL / VERTICAL		
POSICIÓN EN LÍNEA / LINE POSITION	AL FINAL DE LOS COMPONENTES FRL		
END OF ALL FRL COMPONENTS			
TIPO DE COMANDO / DRIVE SYSTEM	ELECTRONEUMÁTICO / ELECTROPNEUMATIC		
SOLENOIDE / SOLENOID	24V DC 3W - 220V AC 5VA		

T100

FR + L



FR + L

CÓDIGO DE LOS PRODUCTOS STANDARD EN STOCK
STANDARD PRODUCTS AVAILABLE IN STOCK

Código Code	Tamaño Size	Rosca Thread	Filtración Filtration	Regulación Regulation	Caudal Flow Rate	Purga Exhaust
T100103231100	FR+L1	1/4	20 µm	0 - 8 bar	1100 NI/min	S/M
T100104231100	FR+L1	3/8	20 µm	0 - 8 bar	1100 NI/min	S/M
T100204231100	FR+L2	3/8	20 µm	0 - 8 bar	2500 NI/min	S/M
T100205231100	FR+L2	1/2	20 µm	0 - 8 bar	2500 NI/min	S/M
T100205232100	FR+L2	1/2	20 µm	0 - 8 bar	2500 NI/min	A
T100307231100	FR+L3	3/4	20 µm	0 - 8 bar	4300 NI/min	S/M
T100309231100	FR+L3	1"	20 µm	0 - 8 bar	4300 NI/min	S/M
T100309232100	FR+L3	1"	20 µm	0 - 8 bar	4300 NI/min	A

S/M: Semiautomático / Manual
Semi Automatic / Manual

A: Automático / Automatic

Codificación artículos para su demanda - Article codes to be used for ordering

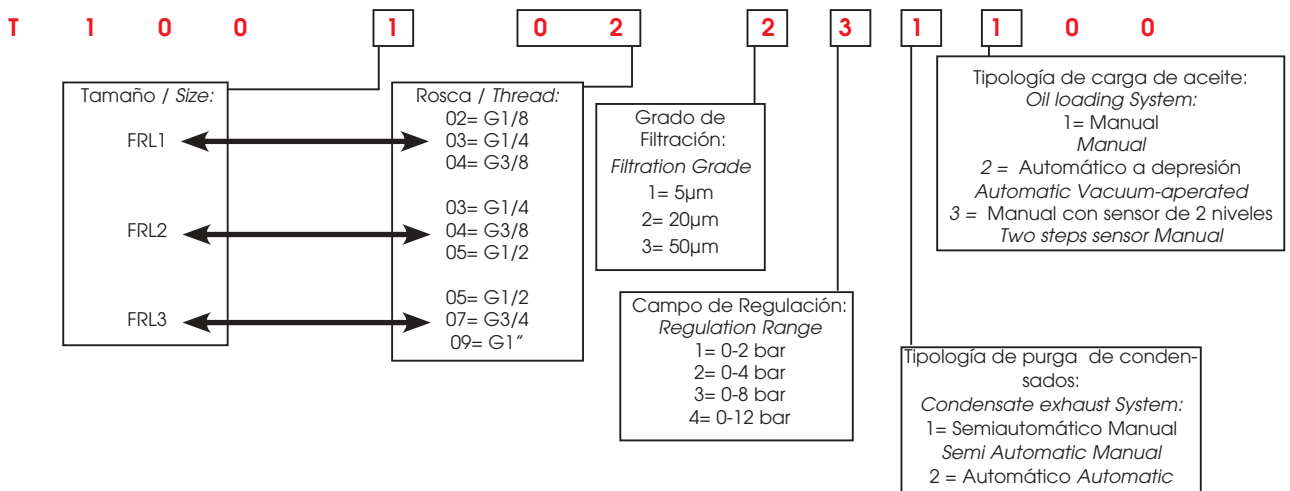

Datos Técnicos - Technical data	FRL 1	FRL 2	FRL 3
CONEXIÓN ROSCADA / THREADED FASTENING	1/8"-1/4"-3/8"	1/4" -3/8"-1/2"	1/2"-3/4"-1"
CAUDAL A 6 BAR CON Δp 1 bar 6 bar FLOW RATE WITH Δp 1 bar	1100 NI/min	2500 NI/min	4300 NI/min
TORNILLOS DE FIJACIÓN / WALL CLAMPING SCREWS	M4X14	M5X18	M6X20
CAPACIDAD TAZA / BOWL CAPACITY	22 cm ³	46 cm ³	89.5 cm ³
CAMPO DE REGULACIÓN / REGULATION RANGE	0 ÷ 2 bar	0 ÷ 4 bar 0 ÷ 8 bar Standard	0 ÷ 12 bar
GRADO DE FILTRACIÓN / FILTRATION GRADE	5µm	20µm Standard	50µm
FLUIDO / FLUID		AIRE COMPRIMIDO / COMPRESSED AIR	
PRESIÓN MAX / MAXIMUM PRESSURE		15 bar	
TEMPERATURA / TEMPERATURE		Min -10 / Max +50°C a/to 10 bar	
CONEXIÓN MANÓMETRO / MANOMETER FASTENING		G 1/8"	
PURGA DE CONDENSADOS / CONDENSATE EXHAUST		SEMIAUTOMÁTICO - MANUAL / SEMI AUTOMATIC - MANUAL AUTOMÁTICO / AUTOMATIC	

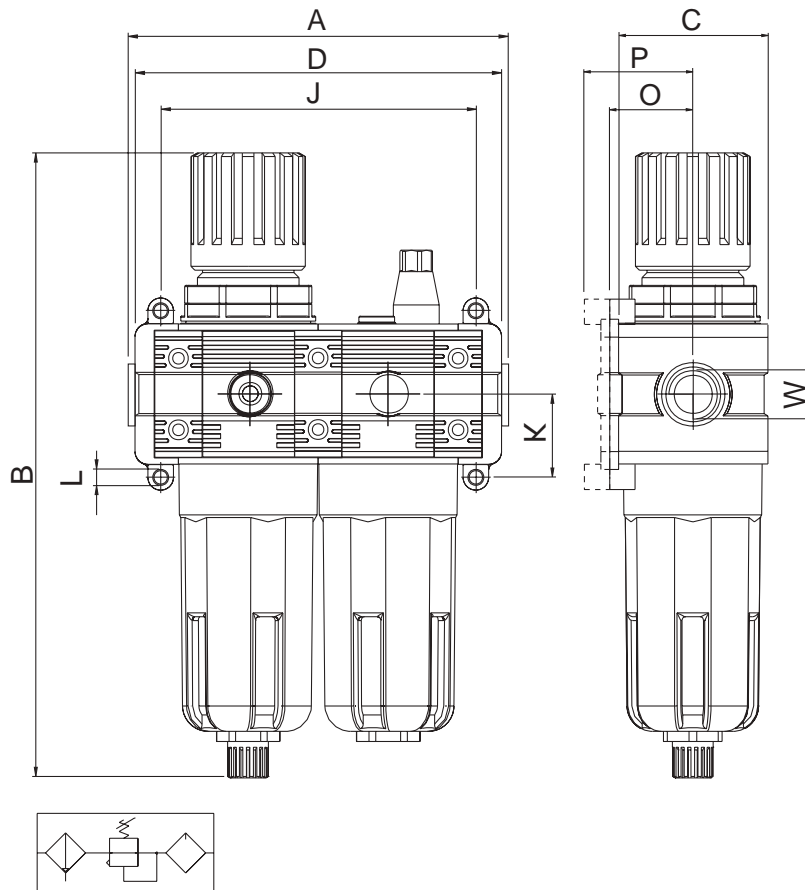

Dimensiones - Dimensions	FRL 1	FRL 2	FRL 3
A	115	144	165
B	198	244.5	273
C	45	59	70
D	119	144	171 171 176
W	1/8" - 1/4" - 3/8"	1/4" - 3/8" - 1/2"	1/2" - 3/4" - 1"
J	124.5	152	174
K	17.25	22	27
L	Ø X M4	Ø X M5	Ø X M6
O	26	32	38.5
P	32.5	38.5	45

T110

V +FR + L



V + FR + L

CÓDIGO DE LOS PRODUCTOS STANDARD EN STOCK
STANDARD PRODUCTS AVAILABLE IN STOCK

Código Code	Tamaño Size	Rosca Thread	Filtración Filtration	Regulación Regulation	Caudal Flow Rate
T110103231110	V+FR+L 1	1/4	20 µm	0 - 8 bar	800 NI/min
T110104231110	V+FR+L 1	3/8	20 µm	0 - 8 bar	800 NI/min
T110204231110	V+FR+L 2	3/8	20 µm	0 - 8 bar	2100 NI/min
T110205231110	V+FR+L 2	1/2	20 µm	0 - 8 bar	2100 NI/min
T110307231110	V+FR+L 3	3/4	20 µm	0 - 8 bar	3500 NI/min
T110309231110	V+FR+L 3	1"	20 µm	0 - 8 bar	3500 NI/min

Codificación artículos para su demanda - Article codes to be used for ordering

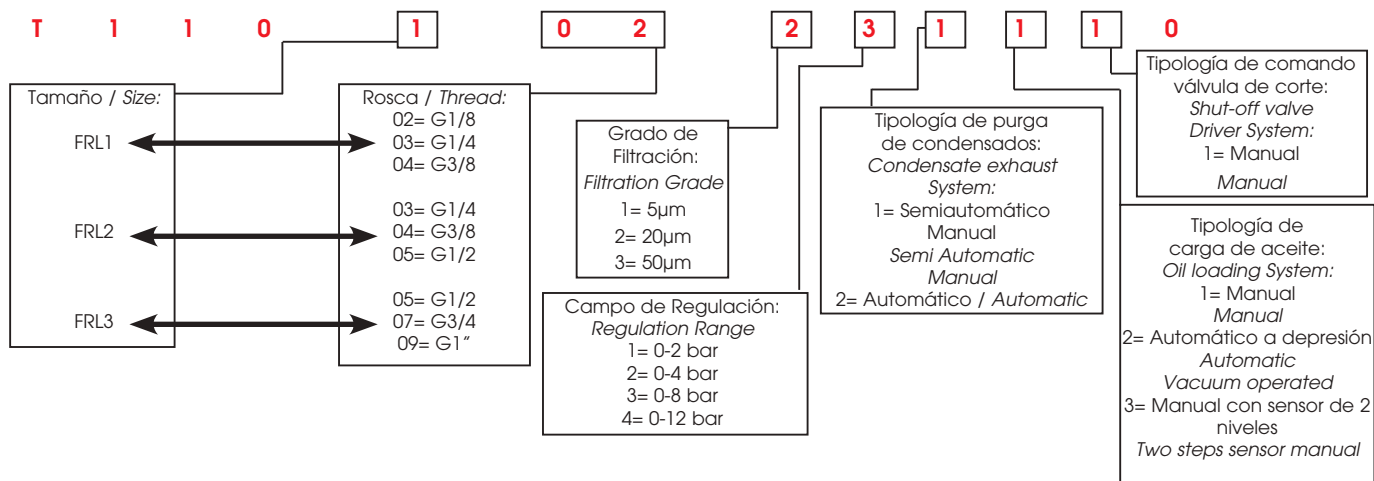

Datos Técnicos - Technical data	FRL 1	FRL 2	FRL 3
CONEXIÓN ROSCADA / THREADED FASTENING	1/8"-1/4"-3/8"	1/4" -3/8"-1/2"	1/2"-3/4"-1"
CAUDAL A 6 BAR CON Δp 1 bar 6 bar FLOW RATE WITH Δp 1 bar	800 NI/min	2100 NI/min	3500 NI/min
TORNILLOS DE FIJACIÓN / WALL CLAMPING SCREWS	M4X14	M5X18	M6X20
CAPACIDAD TAZA / BOWL CAPACITY	22 cm ³	46 cm ³	89.5 cm ³
CAMPO DE REGULACIÓN / REGULATION RANGE	0 ÷ 2 bar	0 ÷ 4 bar 0 ÷ 8 bar Standard	0 ÷ 12 bar
GRADO DE FILTRACIÓN / FILTRATION GRADE	5μm	20μm Standard	50μm
FLUIDO / FLUID		AIRE COMPRIMIDO / COMPRESSED AIR	
PRESIÓN MAX / MAXIMUM PRESSURE		15 bar	
TEMPERATURA / TEMPERATURE		Min -10 / Max +50°C a/to 10 bar	
CONEXIÓN MANÓMETRO / MANOMETER FASTENING		G 1/8"	
PURGA DE CONDENSADOS / CONDENSATE EXHAUST		SEMIAUTOMÁTICO - MANUAL / SEMI AUTOMATIC - MANUAL AUTOMÁTICO / AUTOMATIC	

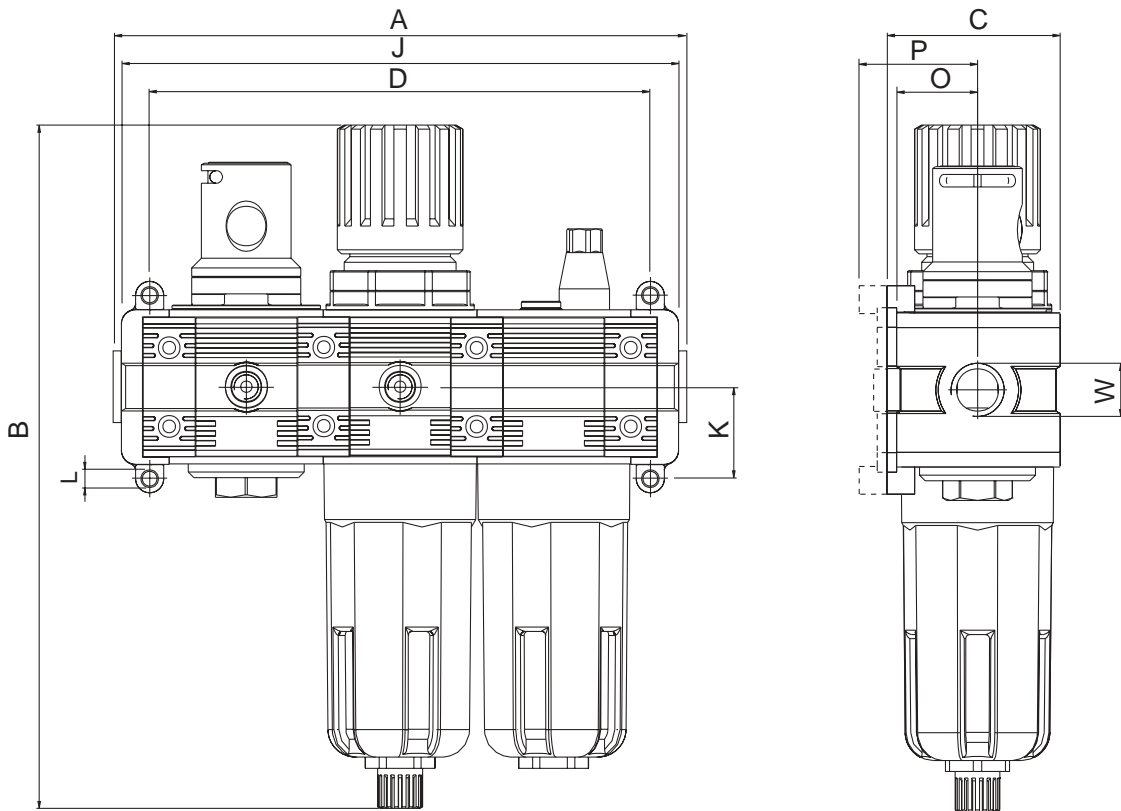

Dimensiones - Dimensions	FRL 1	FRL 2	FRL 3
A	115	144	165
B	198	244.5	273
C	45	59	70
D	118.5	199	236 236 241
W	1/8" - 1/4" - 3/8"	1/4" - 3/8" - 1/2"	1/2" - 3/4" - 1"
J	97	124	144
K	26	32.5	38
L	Ø X M4	Ø X M5	Ø X M6
O	26	32	38.5
P	32.5	38.5	45

T200

F + R + L



F + R + L

CÓDIGO DE LOS PRODUCTOS STANDARD EN STOCK
STANDARD PRODUCTS AVAILABLE IN STOCK

Código Code	Tamaño Size	Rosca Thread	Filtración Filtration	Regulación Regulation	Caudal Flow Rate
T200103231100	F+R+L 1	1/4	20 µm	0 - 8 bar	1000 NI/min
T200104231100	F+R+L 1	3/8	20 µm	0 - 8 bar	1000 NI/min
T200204231100	F+R+L 2	3/8	20 µm	0 - 8 bar	2400 NI/min
T200205231100	F+R+L 2	1/2	20 µm	0 - 8 bar	2400 NI/min
T200307231100	F+R+L 3	3/4	20 µm	0 - 8 bar	4250 NI/min
T200309231100	F+R+L 3	1"	20 µm	0 - 8 bar	4250 NI/min

Codificación artículos para su demanda - Article codes to be used for ordering

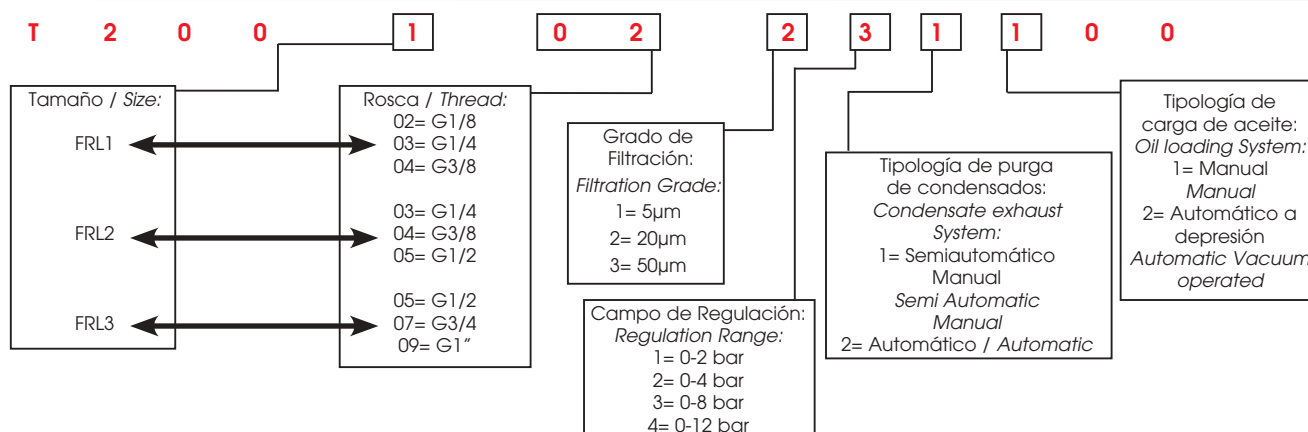

Datos Técnicos - Technical data	FRL 1	FRL 2	FRL 3
CONEXIÓN ROSCADA / THREADED FASTENING	1/8" - 1/4" - 3/8"	1/4" - 3/8" - 1/2"	1/2" - 3/4" - 1"
CAUDAL A 6 BAR CON Δp 1 bar 6 bar FLOW RATE WITH Δp 1 bar	1000 NI/min	2400 NI/min	4250 NI/min
TORNILLOS DE FIJACIÓN / WALL CLAMPING SCREWS	M4X14	M5X18	M6X20
CAPACIDAD TAZA / BOWL CAPACITY	22 cm ³	46 cm ³	89.5 cm ³
CAMPO DE REGULACIÓN / REGULATION RANGE	0 ÷ 2 bar	0 ÷ 4 bar 0 ÷ 8 bar Standard	0 ÷ 12 bar
GRADO DE FILTRACIÓN / FILTRATION GRADE	5μm	20μm Standard	50μm
FLUIDO / FLUID		AIRE COMPRIMIDO / COMPRESSED AIR	
PRESIÓN MAX / MAXIMUM PRESSURE		15 bar	
TEMPERATURA / TEMPERATURE		Min -10 / Max +50°C a/to 10 bar	
CONEXIÓN MANÓMETRO / MANOMETER FASTENING		G 1/8"	
PURGA DE CONDENSADOS / CONDENSATE EXHAUST		SEMIAUTOMÁTICO - MANUAL / SEMI AUTOMATIC - MANUAL AUTOMÁTICO / AUTOMATIC	

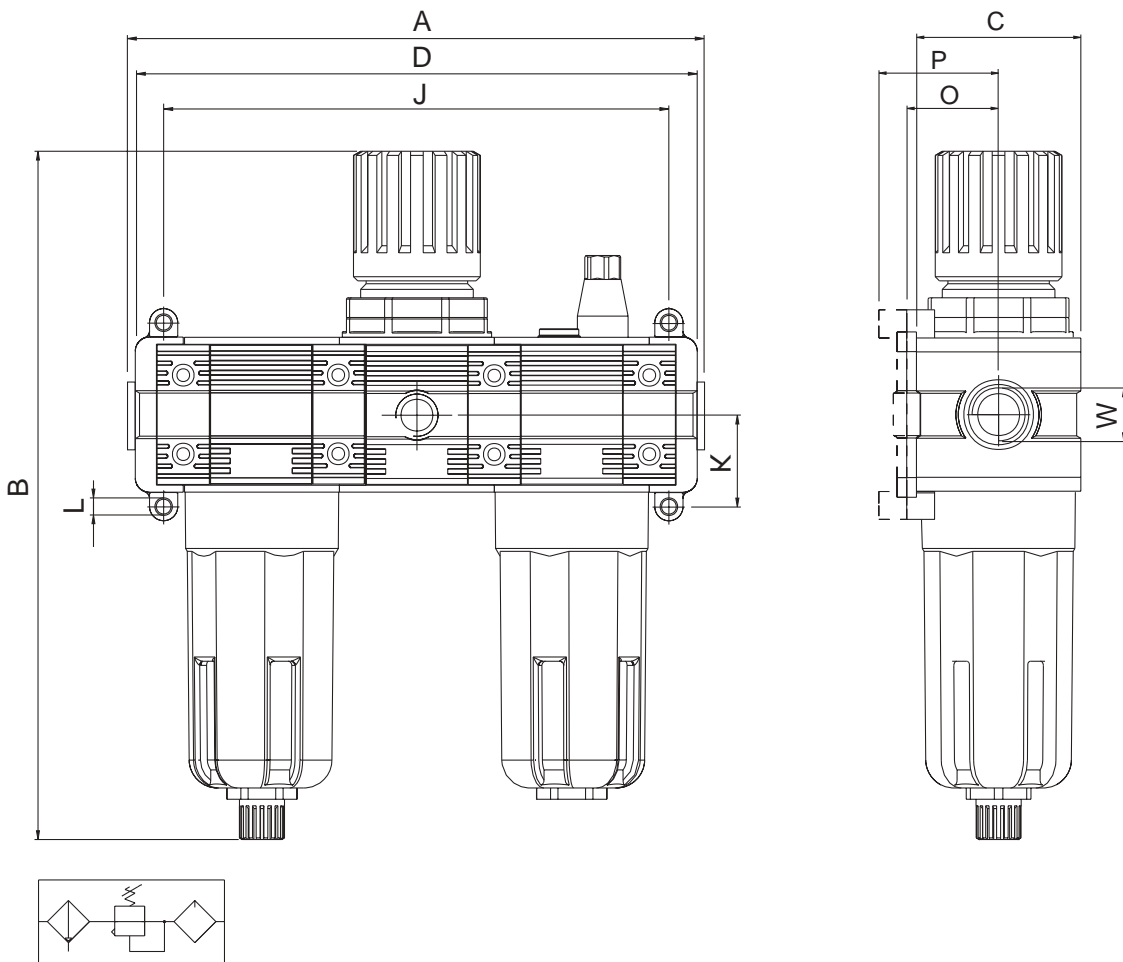

Dimensiones - Dimensions	FRL 1	FRL 2	FRL 3
A	158	199	230
B	198	244.5	273
C	45	59	70
D	161.5	199	236 236 241
W	1/8" - 1/4" - 3/8"	1/4" - 3/8" - 1/2"	1/2" - 3/4" - 1"
J	140	179	209
K	26	32.5	38
L	Ø X M4	Ø X M5	Ø X M6
O	26	32	38.5
P	32.5	38.5	45

T210

V + F + R + L



V + F + R + L

CÓDIGO DE LOS PRODUCTOS STANDARD EN STOCK STANDARD PRODUCTS AVAILABLE IN STOCK

Código Code	Tamaño Size	Rosca Thread	Filtración Filtration	Regulación Regulation	Caudal Flow Rate
T210103231110	V+F+R+L 1	1/4	20 µm	0 - 8 bar	1000 NI/min
T210104231110	V+F+R+L 1	3/8	20 µm	0 - 8 bar	1000 NI/min
T210204231110	V+F+R+L 2	3/8	20 µm	0 - 8 bar	2200 NI/min
T210205231110	V+F+R+L 2	1/2	20 µm	0 - 8 bar	2200 NI/min
T210307231110	V+F+R+L 3	3/4	20 µm	0 - 8 bar	3900 NI/min
T210309231110	V+F+R+L 3	1"	20 µm	0 - 8 bar	3900 NI/min

Codificación artículos para su demanda - Article codes to be used for ordering

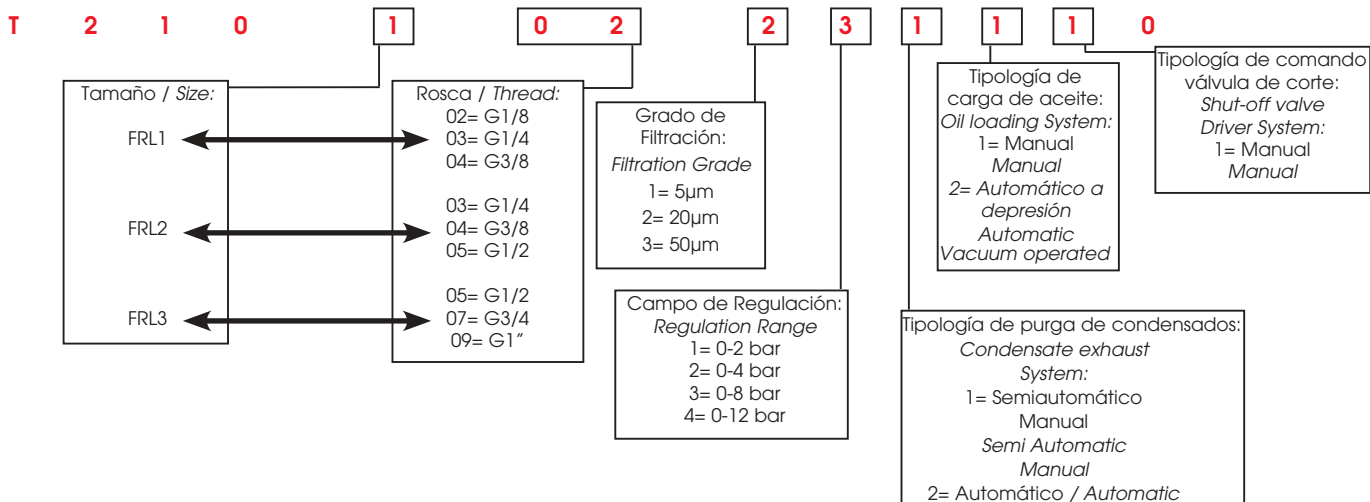

Datos Técnicos - Technical data

	FRL 1	FRL 2	FRL 3
CONEXIÓN ROSCADA / <i>THREADED FASTENING</i>	1/8" - 1/4" - 3/8"	1/4" - 3/8" - 1/2"	1/2" - 3/4" - 1"
CAUDAL A 6 BAR CON Δp 1 bar 6 bar <i>FLOW RATE WITH Δp 1 bar</i>	1000 NI/min	2200 NI/min	3900 NI/min
TORNILLOS DE FIJACIÓN / <i>WALL CLAMPING SCREWS</i>	M4X14	M5X18	M6X20
CAPACIDAD TAZA / <i>BOWL CAPACITY</i>	22 cm ³	46 cm ³	89.5 cm ³
CAMPO DE REGULACIÓN / <i>REGULATION RANGE</i>	0 ÷ 2 bar	0 ÷ 4 bar 0 ÷ 8 bar Standard	0 ÷ 12 bar
GRADO DE FILTRACIÓN / <i>FILTRATION GRADE</i>	5µm	20µm Standard	50µm
FLUIDO / <i>FLUID</i>		AIRE COMPRIMIDO / <i>COMPRESSED AIR</i>	
PRESIÓN MAX / <i>MAXIMUM PRESSURE</i>		15 bar	
TEMPERATURA / <i>TEMPERATURE</i>		Min -10 / Max +50°C a/to 10 bar	
CONEXIÓN MANÓMETRO / <i>MANOMETER FASTENING</i>		G 1/8"	
PURGA DE CONDENSADOS / <i>CONDENSATE EXHAUST</i>		MANUAL - SEMIAUTOMÁTICO / <i>MANUAL SEMI AUTOMATIC</i> AUTOMÁTICO / <i>AUTOMATIC</i>	

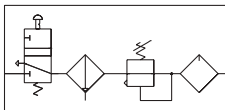
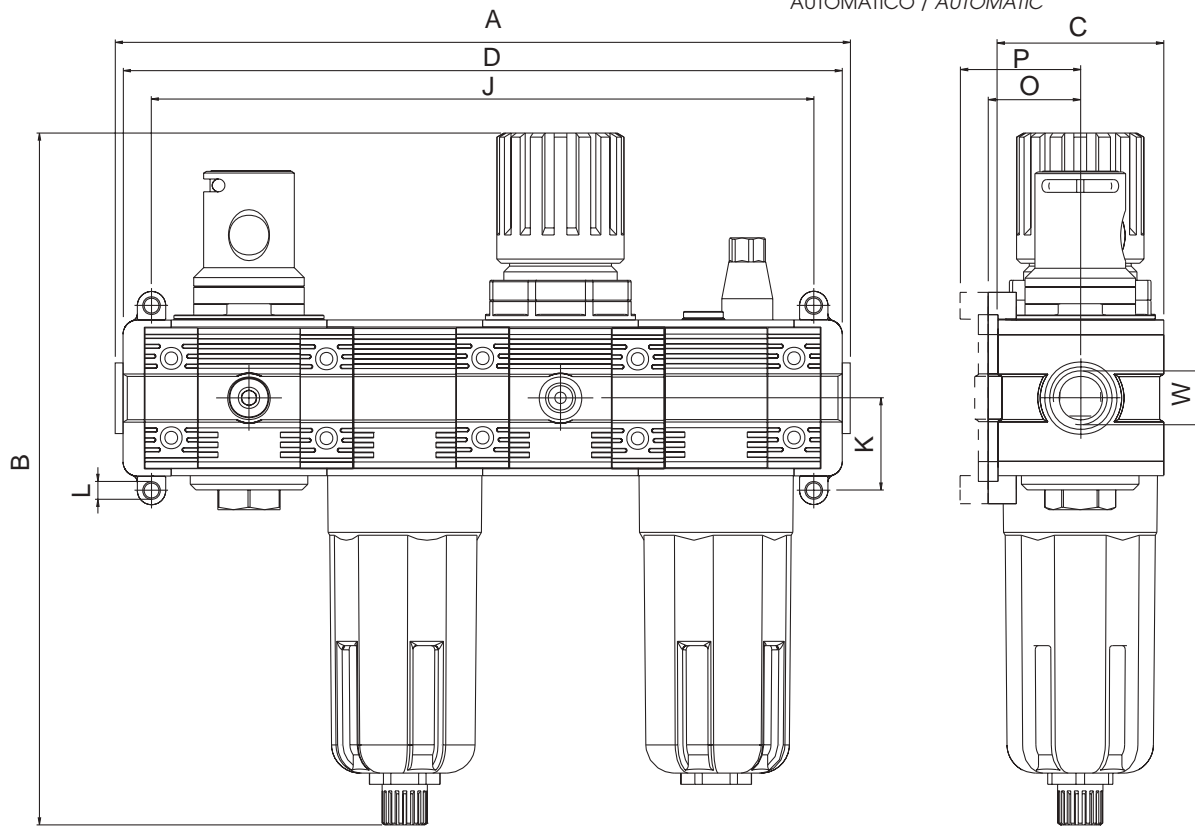
Dimensiones - Dimensions

	FRL 1	FRL 2	FRL 3
A	201	254	295
B	198	244.5	273
C	45	59	70
D	204.5	254	301 301 306
W	1/8" - 1/4" - 3/8"	1/4" - 3/8" - 1/2"	1/2" - 3/4" - 1"
J	183	234	274
K	26	32.5	38
L	Ø X M4	Ø X M5	Ø X M6
O	26	32	38.5
P	32.5	38.5	45

T300

F + L

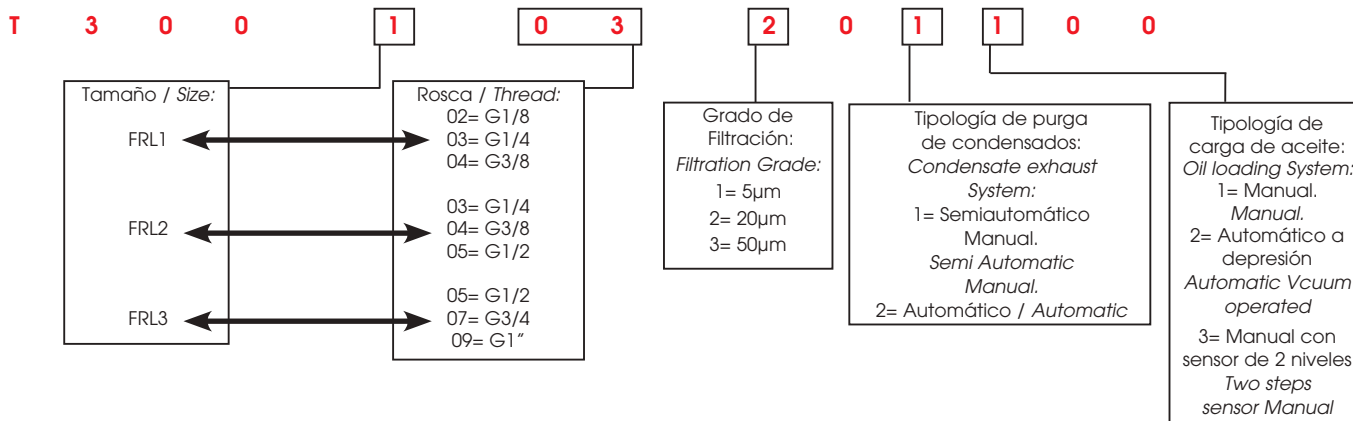

F + L
CÓDIGO DE LOS PRODUCTOS STANDARD EN STOCK
STANDARD PRODUCTS AVAILABLE IN STOCK

Código Code	Tamaño Size	Rosca Thread	Filtración Filtration	Caudal Flow Rate
T300103201100	F+L 1	1/4	20 µm	1350 NI/min
T300104201100	F+L 1	3/8	20 µm	1350 NI/min
T300204201100	F+L 2	3/8	20 µm	3200 NI/min
T300205201100	F+L 2	1/2	20 µm	3200 NI/min
T300307201100	F+L 3	3/4	20 µm	5000 NI/min
T300309201100	F+L 3	1"	20 µm	5000 NI/min

Codificación artículos para su demanda - Article codes to be used for ordering

Datos Técnicos - Technical data

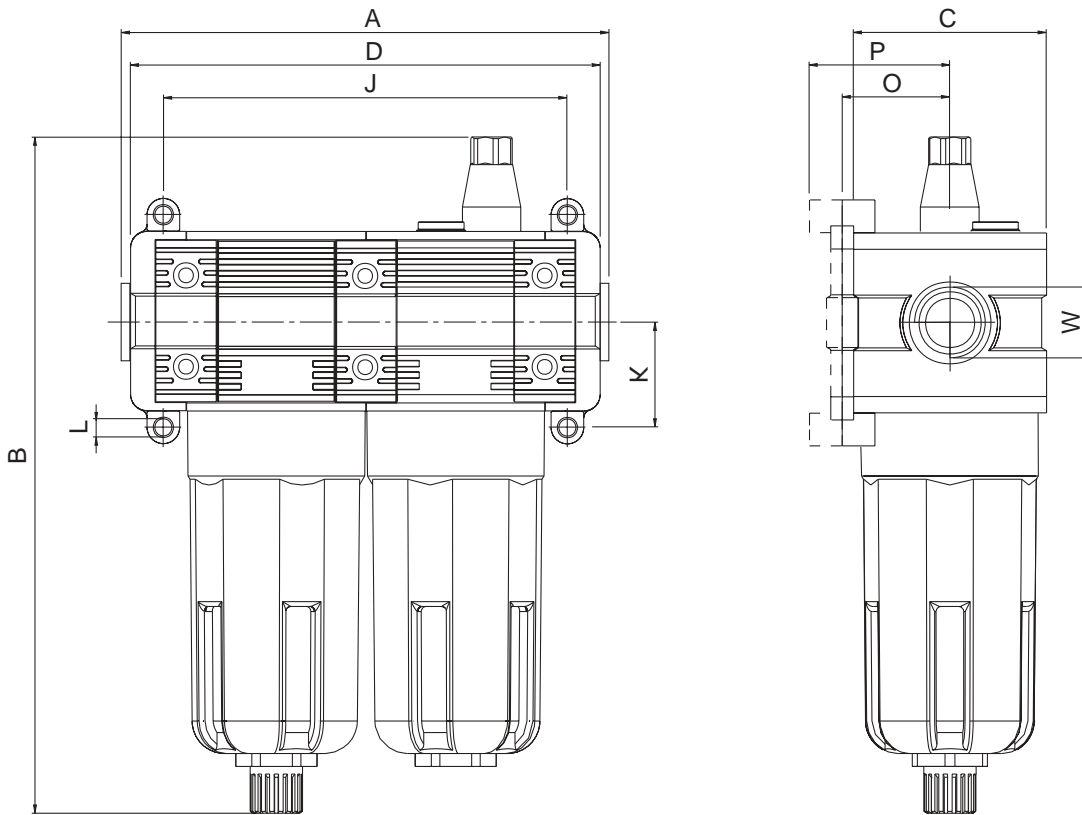
	FRL 1	FRL 2	FRL 3
CONEXIÓN ROSCADA / THREADED FASTENING	1/8"-1/4"-3/8"	1/4" -3/8"-1/2"	1/2"-3/4"-1"
CAUDAL A 6 BAR CON Δp A 1 bar 6 bar FLOW RATE WITH Δp AT 1 bar	1350 NI/min	3200 NI/min	5000 NI/min
TORNILLOS DE FIJACIÓN / WALL CLAMPING SCREWS	M4X14	M5X18	M6X20
CAPACIDAD TAZA / BOWL CAPACITY	22 cm ³	46 cm ³	89.5 cm ³
GRADO DE FILTRACIÓN / FILTRATION GRADE	5μm	20μm Standard	50μm
FLUIDO / FLUID	AIRE COMPRIMIDO / COMPRESSED AIR		
PRESIÓN MAX / MAXIMUM PRESSURE	15 bar		
TEMPERATURA / TEMPERATURE	Min -10 / Max +50°C a/to 10 bar		
PURGA DE CONDENSADOS / CONDENSATE EXHAUST	MANUAL - SEMIAUTOMÁTICO / MANUAL SEMI AUTOMATIC AUTOMÁTICO / AUTOMATIC		

Dimensiones - Dimensions

	FRL 1	FRL 2	FRL 3
A	115	144	165
B	175	207.5	226.5
C	45	59	70
D	118.5	144	171 171 176
W	1/8" - 1/4" - 3/8"	1/4" - 3/8" - 1/2"	1/2" - 3/4" - 1"
J	97	124	144
K	26	32.5	38
L	Ø X M4	Ø X M5	Ø X M6
O	26	32	38.5
P	32.5	38.5	45

T400

FIL + FC



FIL + FC

CÓDIGO DE LOS PRODUCTOS STANDARD EN STOCK
STANDARD PRODUCTS AVAILABLE IN STOCK

Código Code	Tamaño Size	Rosca Thread	Filtración Filtration	Caudal Flow Rate
T400103401000	FIL+FC 1	1/4	5 µm + 0.01 µm	600 NI/min
T400104401000	FIL+FC 1	3/8	5 µm + 0.01 µm	600 NI/min
T400204401000	FIL+FC 2	3/8	5 µm + 0.01 µm	660 NI/min
T400205401000	FIL+FC 2	1/2	5 µm + 0.01 µm	660 NI/min
T400307401000	FIL+FC 3	3/4	5 µm + 0.01 µm	910 NI/min
T400309401000	FIL+FC 3	1"	5 µm + 0.01 µm	910 NI/min

Codificación artículos para su demanda - Article codes to be used for ordering

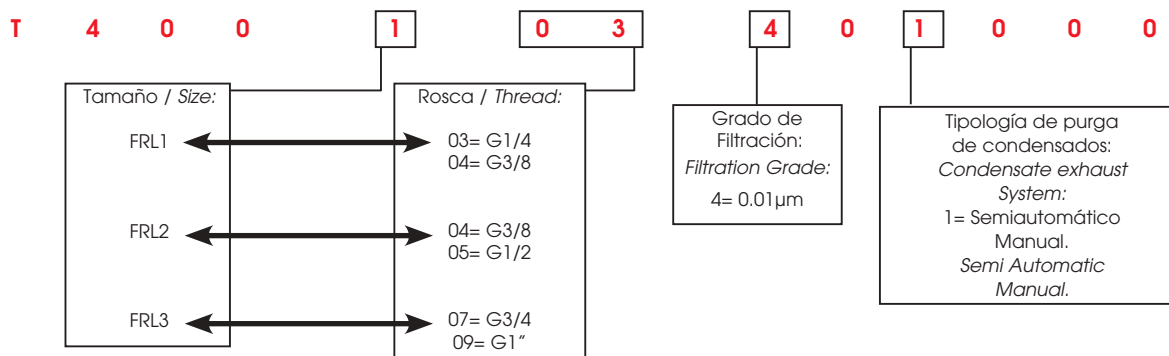

Datos Técnicos - Technical data

	FRL 1	FRL 2	FRL 3
CONEXIÓN ROSCADA / THREADED FASTENING	1/4"-3/8"	3/8"-1/2"	3/4"-1"
CAUDAL A 6 BAR CON Δp A 1 bar 6 bar FLOW RATE WITH Δp AT 1 bar	600 NI/min	660 NI/min	910 NI/min
TORNILLOS DE FIJACIÓN / WALL CLAMPING SCREWS	M4X14	M5X18	M6X20
CAPACIDAD TAZA / BOWL CAPACITY	22 cm ³	46 cm ³	89.5 cm ³
GRADO DE FILTRACIÓN / FILTRATION GRADE		5µm + 0.01µm	
FLUIDO / FLUID		AIRE COMPRIMIDO / COMPRESSED AIR	
PRESIÓN MAX / MAXIMUM PRESSURE		15 bar	
TEMPERATURA / TEMPERATURE		Min -10 / Max +50°C a/to 10 bar	
PURGA DE CONDENSADOS / CONDENSATE EXHAUST		MANUAL - SEMIAUTOMÁTICO / MANUAL SEMI AUTOMATIC	

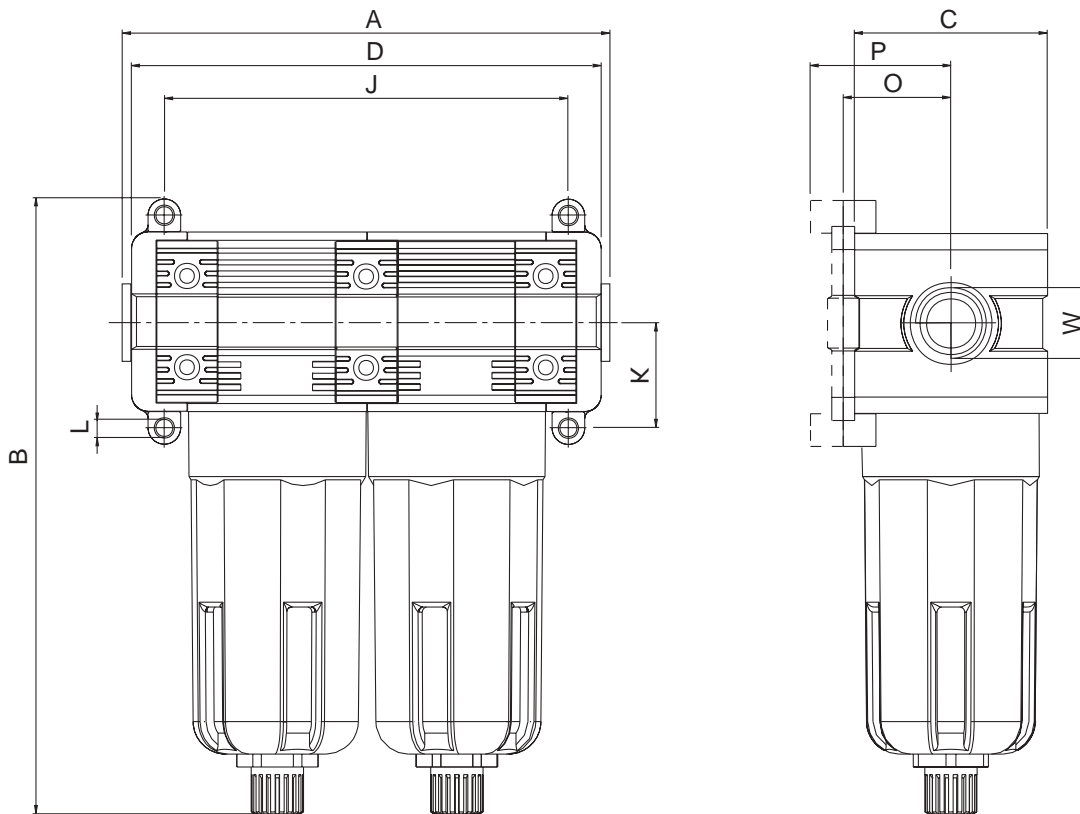
Dimensiones - Dimensions

	FRL 1	FRL 2	FRL 3
A	115	144	165
B	146	178.5	197.5
C	45	59	70
D	118.5	144	171 171 176
W	1/8" - 1/4" - 3/8"	1/4" - 3/8" - 1/2"	1/2" - 3/4" - 1"
J	97	124	144
K	26	32.5	38
L	Ø X M4	Ø X M5	Ø X M6
O	26	32	38.5
P	32.5	38.5	45

T450

FR + FC

FR + FC
CÓDIGO DE LOS PRODUCTOS STANDARD EN STOCK
STANDARD PRODUCTS AVAILABLE IN STOCK

Código Code	Tamaño Size	Rosca Thread	Regulación Regulation	Filtración Filtration	Caudal Flow Rate
T450103431000	FR+FC 1	1/4	0 - 8 bar	5 µm + 0.01 µm	600 NI/min
T450104431000	FR+FC 1	3/8	0 - 8 bar	5 µm + 0.01 µm	600 NI/min
T450204431000	FR+FC 2	3/8	0 - 8 bar	5 µm + 0.01 µm	660 NI/min
T450205431000	FR+FC 2	1/2	0 - 8 bar	5 µm + 0.01 µm	660 NI/min
T450307431000	FR+FC 3	3/4	0 - 8 bar	5 µm + 0.01 µm	910 NI/min
T450309431000	FR+FC 3	1"	0 - 8 bar	5 µm + 0.01 µm	910 NI/min

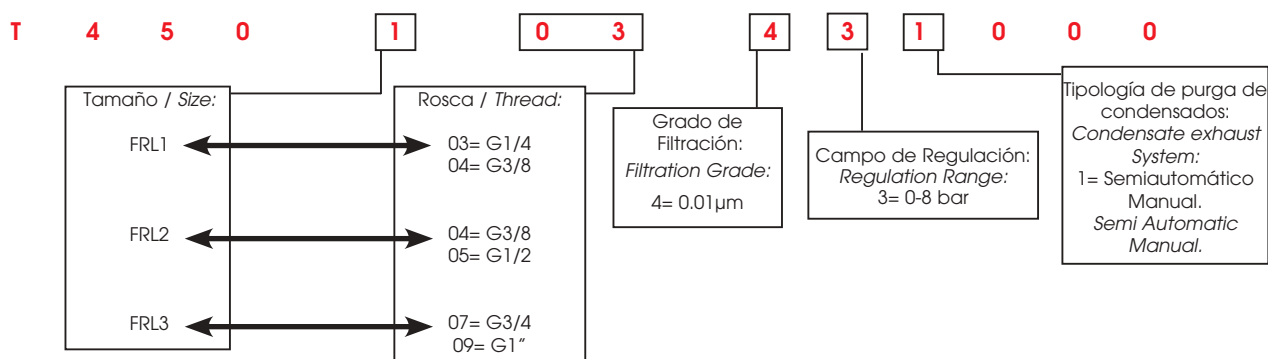
Codificación artículos para su demanda - Article codes to be used for ordering

Datos Técnicos - Technical data	FRL 1	FRL 2	FRL 3
CONEXIÓN ROSCADA / THREADED FASTENING	1/4"-3/8"	3/8"-1/2"	3/4"-1"
CAUDAL A 6 BAR CON Δp A 1 bar 6 bar FLOW RATE WITH Δp AT 1 bar	600 NI/min	660 NI/min	910 NI/min
TORNILLOS DE FIJACIÓN / WALL CLAMPING SCREWS	M4X14	M5X18	M6X20
CAPACIDAD TAZA / BOWL CAPACITY	22 cm ³	46 cm ³	89.5 cm ³
GRADO DE FILTRACIÓN / FILTRATION GRADE		5μm + 0.01μm	
CAMPO DE REGULACIÓN / REGULATION RANGE		0-8 bar	
FLUIDO / FLUID		AIRE COMPRIMIDO / COMPRESSED AIR	
PRESIÓN MAX / MAXIMUM PRESSURE		15 bar	
TEMPERATURA / TEMPERATURE		Min -10 / Max +50°C a/to 10 bar	
PURGA DE CONDENSADOS / CONDENSATE EXHAUST		MANUAL - SEMIAUTOMÁTICO / MANUAL SEMI AUTOMATIC	

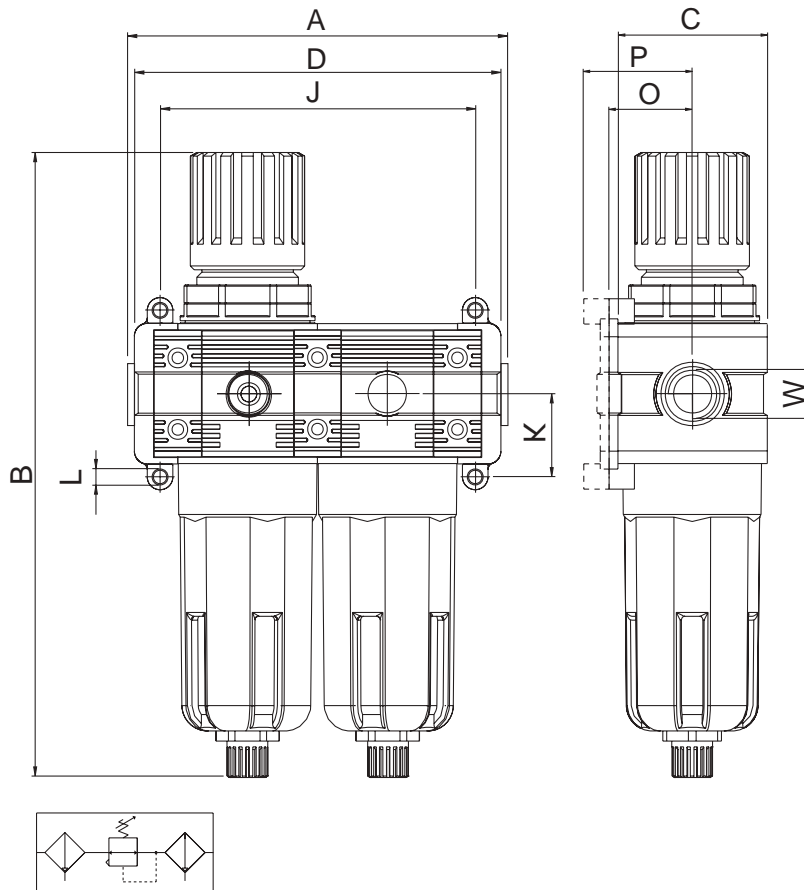

Dimensiones - Dimensions	FRL 1	FRL 2	FRL 3
A	115	144	165
B	146	178.5	197.5
C	45	59	70
D	118.5	144	171 171 176
W	1/8" - 1/4" - 3/8"	1/4" - 3/8" - 1/2"	1/2" - 3/4" - 1"
J	97	124	144
K	26	32.5	38
L	Ø X M4	Ø X M5	Ø X M6
O	26	32	38.5
P	32.5	38.5	45

T500
Placas de Unión
Connection Plate

MINI

Código Code	
T500000000000	FRL 0
T500100000000	FRL 1
T500200000000	FRL 2
T500300000000	FRL 3

T505
Grupo Terminales
Ends Unit

Código Code	
T505102000000	FRL 1 1/8
T505103000000	FRL 1 1/4
T505104000000	FRL 1 3/8
T505203000000	FRL 2 1/4
T505204000000	FRL 2 3/8
T505205000000	FRL 2 1/2
T505305000000	FRL 3 1/2
T505307000000	FRL 3 3/4
T505309000000	FRL 3 1"

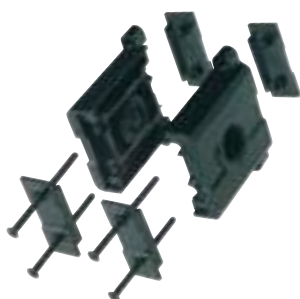
T510
Grupo de Unión
Connection Unit

Código Code	
T510102000000	FRL 1 1/8
T510103000000	FRL 1 1/4
T510104000000	FRL 1 3/8
T510203000000	FRL 2 1/4
T510204000000	FRL 2 3/8
T510205000000	FRL 2 1/2
T510305000000	FRL 3 1/2
T510307000000	FRL 3 3/4
T510309000000	FRL 3 1"

T540
Grupo Portafiltro
Filter Ring Device

MINI

T540000100000	FRL 0 5 µm
T540000200000	FRL 0 20 µm
T540000300000	FRL 0 50 µm
T540100100000	FRL 1 5 µm
T540100200000	FRL 1 20 µm
T540100300000	FRL 1 50 µm
T540200100000	FRL 2 5 µm
T540200200000	FRL 2 20 µm
T540200300000	FRL 2 50 µm
T540300100000	FRL 3 5 µm
T540300200000	FRL 3 20 µm
T540300300000	FRL 3 50 µm

T545
Filtro Coalescente
Coalescer Filter

MINI

Código Code	
T545000000000	FRL 0
T545100000000	FRL 1
T545200000000	FRL 2
T545300000000	FRL 3

MAN01
Manómetro
Manometer

Código Code	
MAN01N2040000	Ø40 0-12 bar R1/8

REG06
Muelle de Registro
Register Spring

Código Code	
REG06005401SC	FRL 0 0-2 BAR
REG06005402SC	FRL 0 0-4 BAR
REG06005403SC	FRL 0 0-8 BAR
REG06005404SC	FRL 0 0-12 BAR
REG06105401SC	FRL 1 0-2 BAR
REG06105402SC	FRL 1 0-4 BAR
REG06105403SC	FRL 1 0-8 BAR
REG06105404SC	FRL 1 0-12 BAR
REG06205401SC	FRL 2 0-2 BAR
REG06205402SC	FRL 2 0-4 BAR
REG06205403SC	FRL 2 0-8 BAR
REG06205404SC	FRL 2 0-12 BAR
REG06305401SC	FRL 3 0-2 BAR
REG06305402SC	FRL 3 0-4 BAR
REG06305403SC	FRL 3 0-8 BAR
REG06305404SC	FRL 3 0-12 BAR

REG09
Grupo Membrana
Membrane Unit

Código Code	
REG09001700SC	FRL 0
REG09101700SC	FRL 1
REG09201700SC	FRL 2
REG09301700SC	FRL 3

T550

Grupo Venturi
Venturi Unit



Código Code	
T55000000000	FRL 0
T55010000000	FRL 1
T55020000000	FRL 2
T55030000000	FRL 3

T560

Cúpula lubricador
Oil Feeding Device



Código Code	
T560100000000	FRL 0
T560100000000	FRL 1
T560100000000	FRL 2
T560100000000	FRL 3

T570

Grupo de Regulación
Regulating Device



Código Code	
T570000010000	FRL 0 0-2 BAR
T570000020000	FRL 0 0-4 BAR
T570000030000	FRL 0 0-8 BAR
T570000040000	FRL 0 0-12 BAR
T570100010000	FRL 1 0-2 BAR
T570100020000	FRL 1 0-4 BAR
T570100030000	FRL 1 0-8 BAR
T570100040000	FRL 1 0-12 BAR
T570200010000	FRL 2 0-2 BAR
T570200020000	FRL 2 0-4 BAR
T570200030000	FRL 2 0-8 BAR
T570200040000	FRL 2 0-12 BAR
T570300010000	FRL 3 0-2 BAR
T570300020000	FRL 3 0-4 BAR
T570300030000	FRL 3 0-8 BAR
T570300040000	FRL 3 0-12 BAR

T580

Grupo Tapón Regulador
Regulating Plug Unit



Código Code	
T580000000000	FRL 0
T580100000000	FRL 1
T580200000000	FRL 2
T580300000000	FRL 3

T590

Grupo Obturador + Filtro
Shutter + Filter Unit



Código Code	
T590000100000	FRL 0 5 µm
T590000200000	FRL 0 20 µm
T590000300000	FRL 0 50 µm
T590100100000	FRL 1 5 µm
T590100200000	FRL 1 20 µm
T590100300000	FRL 1 50 µm
T590200100000	FRL 2 5 µm
T590200200000	FRL 2 20 µm
T590200300000	FRL 2 50 µm
T590300100000	FRL 3 5 µm
T590300200000	FRL 3 20 µm
T590300300000	FRL 3 50 µm

FIL04

Filtro Sinterizado
Sintered Filter



Código Code	
FIL04003805SC	FRL 0 5 µm
FIL04003820SC	FRL 0 20 µm
FIL04003850SC	FRL 0 50 µm
FIL04101005SC	FRL 1 5 µm
FIL04101020SC	FRL 1 20 µm
FIL04101050SC	FRL 1 50 µm
FIL04201005SC	FRL 2 5 µm
FIL04201020SC	FRL 2 20 µm
FIL04201050SC	FRL 2 50 µm
FIL04301005SC	FRL 3 5 µm
FIL04301020SC	FRL 3 20 µm
FIL04301050SC	FRL 3 50 µm

DIS00

Distribuidor de Aire
Air Distributor

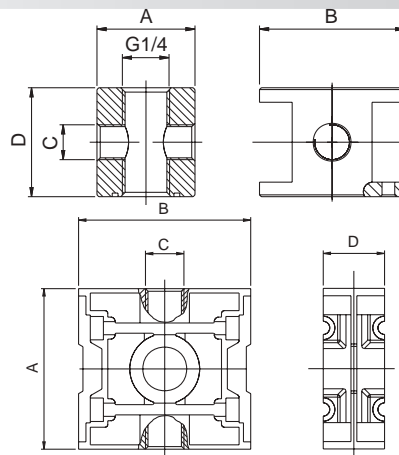
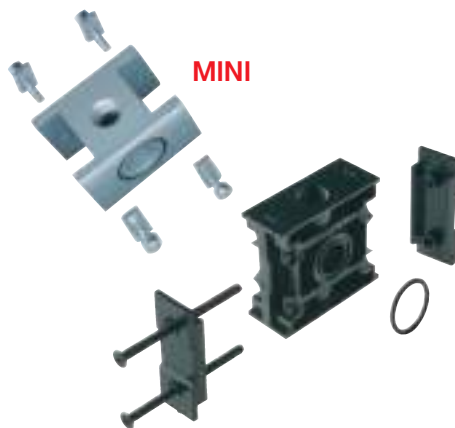

Código Code		A	B	C	D
DIS00001100NE	FRL 0	27	40	1/8	30
DIS00108000NE	FRL 1	42	45	1/4	24
DIS00208000NE	FRL 2	55	59	1/4	24
DIS00308000NE	FRL 3	65	70	3/8	32

T520

Grupo Taza Filtro
Bowl for Filter Unit

MINI



Código Code	
T52000001000	FRL 0
T520100001000	FRL 1
T520200001000	FRL 2
T520300001000	FRL 3

T525

Grupo Taza Filtro con Purga Automática
Bowl for Automatic Condensed Exhaust



Código Code	
T525200002000	FRL 2
T525300002000	FRL 3

T530

Grupo Taza Lubricador
Bowl for Lubricator Unit

MINI



Código Code	
T530000000100	FRL 0
T530100000100	FRL 1
T530200000100	FRL 2
T530300000100	FRL 3

T535

Grupo Taza Carga automática aceite
Bowl for Automatic oil loading system



Código Code	
T535100000200	FRL 1
T535200000200	FRL 2
T535300000200	FRL 3

REG16

Soporte de Fijación
Clamp Bracket

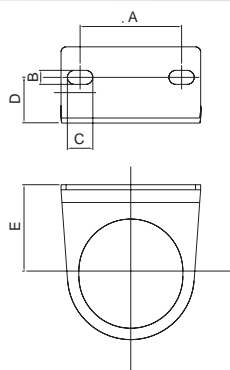

Código Code		A	B	C	D	E
REG16005000NE	FRL 0	21.5	5.5	12	15	31
REG16105000NE	FRL 1	28	5.5	10	15	29
REG16205000NE	FRL 2	40	5.5	10	18	35
REG16305000NE	FRL 3	50	5.5	10	20	39

SOL01

Solenoide
Solenoid



Código Code	
SOL01024C1000	24V DC 3W
SOL01220A2000	220V AC 5VA



ITALIA
Via Don G. Bazzoli, 34
25070 Bione (BS)
T. +39 0365896626
F. +39 0365896561
aignep@aignep.it
www.aignep.com



U.S.A.
320 PREMIER CT #224
FRANKLIN, TN 37067
PH: 615-771-6650
FX: 615-771-0926
service@alphafittings.com
www.alphafittings.com



IBERICA
Pol. Ind. el Tortuguier "Can Prat",
Naves 23 y 24
08691 MONISTROL
DE MONTSERRAT (Barcelona)
T. 93 828 47 36
F. 93 828 44 32
aignep@aignep.es
www.aignep.com



SWITZERLAND
AIGNEP AG - Römerstrasse 7
CH-2555 Brugg - SCHWEIZ
T. +41 32 342 09 09
F. +41 32 342 09 11
aignep.ch@aignep.com
www.aignep.com

2012 ABRIL

www.aignep.com